

# INSTALLATION GUIDE

# NI PXIe-8133

This document contains information about installing your NI PXIe-8133 controller in a PXI Express chassis. For complete configuration and troubleshooting information (including information about BIOS setup, adding RAM, and so on), see the *NI PXIe-8133 User Manual*. The manual is in PDF format on the documentation CD included with your controller and on the National Instruments Web site, [ni.com/manuals](http://ni.com/manuals).

## Installing the NI PXIe-8133

---

This section contains general installation instructions for the NI PXIe-8133. Consult your PXI Express chassis user manual for specific instructions and warnings.

1. Plug in your chassis before installing the NI PXIe-8133. The power cord grounds the chassis and protects it from electrical damage while you install the module.



**Caution** To protect both yourself and the chassis from electrical hazards, leave the chassis powered off until you finish installing the NI PXIe-8133 module.

2. Remove any panels blocking access to the system controller slot (Slot 1) in the chassis.
3. Touch the metal part of the chassis case to discharge any static electricity that might be on your clothes or body.
4. Remove the protective plastic covers from the four bracket-retaining screws as shown in Figure 1.
5. Make sure the injector/ejector handle is in its downward position. Align the NI PXIe-8133 with the card guides on the top and bottom of the system controller slot.

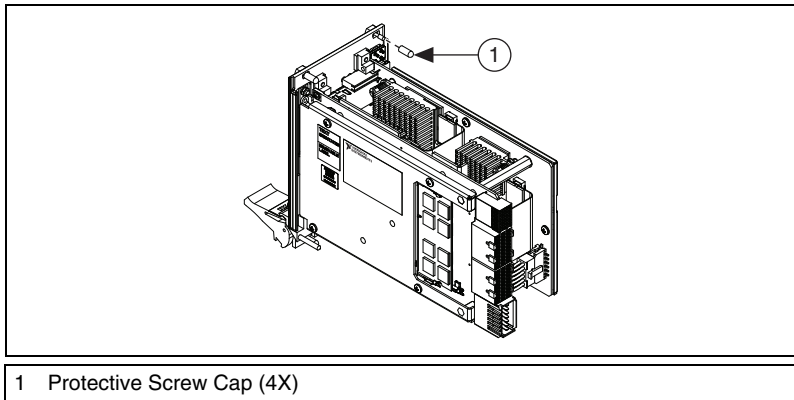

**Figure 1.** Removing Protective Screw Caps



**Caution** Do *not* raise the injector/ejector handle as you insert the NI PXIe-8133. The module will not insert properly unless the handle is in its downward position so that it does not interfere with the injector rail on the chassis.

6. Hold the handle as you slowly slide the module into the chassis until the handle catches on the injector/ejector rail.
7. Raise the injector/ejector handle until the module firmly seats into the backplane receptacle connectors. The front panel of the NI PXIe-8133 should be even with the front panel of the chassis.
8. Tighten the four bracket-retaining screws on the top and bottom of the front panel to secure the NI PXIe-8133 to the chassis.
9. Check the installation.
10. Connect the keyboard and mouse to the USB connectors. If you are using a PS/2 keyboard and a PS/2 mouse, a Y-splitter adapter is available to connect both to a single USB connector. National Instruments offers a Y-splitter adapter cable, part number 778713-02, available through the online catalog at [ni.com/products](http://ni.com/products).
11. Connect the DVI monitor video cable to the DVI connector, or use the DVI-to-VGA adapter included with your controller to connect a VGA monitor to the DVI connector.
12. Connect devices to ports as required by your system configuration.
13. Power on the chassis.
14. Verify that the controller boots. If it does not boot, refer to the [What If the NI PXIe-8133 Does Not Boot?](#) section later in this guide.

Figure 2 shows an NI PXIe-8133 installed in the system controller slot of a National Instruments NI PXIe-1082 chassis.

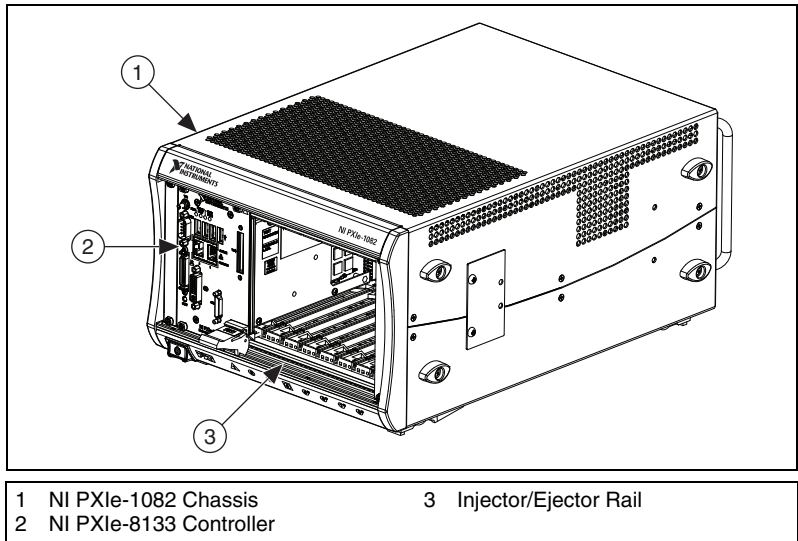

**Figure 2.** NI PXIe-8133 Controller Installed in a PXI Express Chassis

## How to Remove the Controller from the PXI Express Chassis

The NI PXIe-8133 controller is designed for easy handling. To remove the unit from the PXI Express chassis, complete the following steps.

1. Power off the chassis.
2. Unscrew the 4 bracket-retaining screws in the front panel.
3. Press the injector/ejector handle down.
4. Slide the unit out of the chassis.

## What If the NI PXIe-8133 Does Not Boot?

Several problems can cause a controller not to boot. Here are some things to look for and possible solutions.

### Things to Notice

- Which LEDs come on? The **PWROK/FAULT** LED should stay lit green. The **Drive** LED should blink during boot as the disk is accessed.
- What appears on the display? Does it hang at some particular point (BIOS, Operating System, and so on)? If nothing appears on the screen, try a different monitor. Does your monitor work with a different PC? If it hangs, note the last screen output that you saw for reference when consulting National Instruments technical support.

- What has changed about the system? Did you recently move the system? Was there electrical storm activity? Did you recently add a new module, memory chip, or piece of software?
- Refer to your chassis user manual for additional troubleshooting steps.

## Things to Try

- Make sure the chassis is plugged in to a working power source.
- Check any fuses or circuit breakers in the chassis or other power supply (possibly a UPS).
- Make sure the controller module is firmly seated in the chassis.
- Remove all other modules from the chassis.
- Remove any nonessential cables or devices.
- Try the controller in a different chassis.
- Try a similar controller in this same chassis.
- Clear the CMOS. (Refer to the *System CMOS* section of the *NI PXIe-8133 User Manual*.)
- Recover the hard drive on the controller. (Refer to the *Hard Drive Recovery* section of the *NI PXIe-8133 User Manual*.)
- Make sure the RAM is properly seated.

For more troubleshooting information, refer to the *NI PXIe-8133 User Manual*. The manual is in PDF format on the recovery CD included with your controller and on the National Instruments Web site, [ni.com/manuals](http://ni.com/manuals).

## What If I Can't See The Video?

---

This problem usually results from having the video card output set past the limits of the monitor. You will need to boot Windows in Safe Mode. To do this, reboot the controller. As Windows begins to boot, hold down <F8>. You should now be able to reset the video driver to lower settings. Try setting the resolution to 800 × 600 and the refresh rate to 60 Hz. Once you reboot, you can raise these values again, using the test option in Windows. These settings are accessible through the **Advanced** tab of the **Display** item in the **Control Panel**. Alternately, you can try a different monitor, preferably a newer and larger one.

LabVIEW, National Instruments, NI, ni.com, the National Instruments corporate logo, and the Eagle logo are trademarks of National Instruments Corporation. Refer to the *Trademark Information* at [ni.com/trademarks](http://ni.com/trademarks) for other National Instruments trademarks. Other product and company names mentioned herein are trademarks or trade names of their respective companies. For patents covering National Instruments products/technology, refer to the appropriate location: **Help»Patents** in your software, the `patents.txt` file on your media, or the *National Instruments Patent Notice* at [ni.com/patents](http://ni.com/patents).