

FieldPoint™ Operating Instructions

FP-DIO-550 and cFP-DIO-550

Eight-Channel Digital Input, Eight-Channel Digital Output Module

These operating instructions describe how to install and use the National Instruments FP-DIO-550 and cFP-DIO-550 digital I/O modules, referred to inclusively as the [c]FP-DIO-550. For information about configuring and accessing the [c]FP-DIO-550 over a network, refer to the user manual for the FieldPoint network module you are using.

Features

The [c]FP-DIO-550 is a FieldPoint digital I/O module with the following features:

- Eight digital input channels compatible with sinking, sourcing, and differential devices
- Eight sourcing digital output channels
- Up to 30 VDC digital input
- Up to 30 VDC, 250 mA digital output
- On/Off LED indicators
- 250 V_{rms} CAT II continuous channel-to-ground isolation, verified by 2,300 V_{rms}, 5 s dielectric withstand test
- Hot swappable

Installing the FP-DIO-550

The FP-DIO-550 mounts on a FieldPoint terminal base (FP-TB-*x*), which provides operating power to the module. Installing the FP-DIO-550 onto a powered terminal base does not disrupt the operation of the bank.

To install the FP-DIO-550, refer to Figure 1 and complete the following steps:

1. Slide the terminal base key to position X.
2. Align the FP-DIO-550 alignment slots with the guide rails on the terminal base.
3. Press firmly to seat the FP-DIO-550 on the terminal base. When the module is firmly seated, the terminal base latch locks it into place.

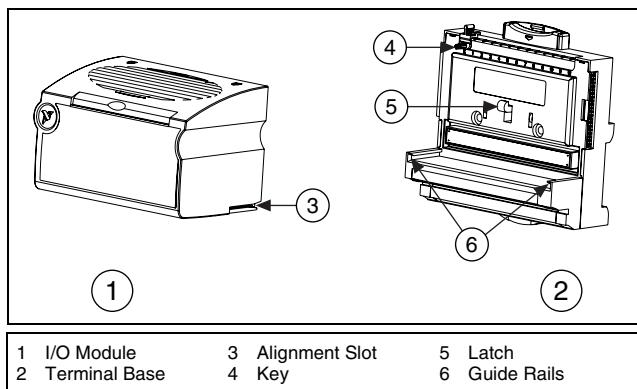

Figure 1. Installing the FP-DIO-550

Installing the cFP-DIO-550

The cFP-DIO-550 mounts on a Compact FieldPoint backplane (cFP-BP-*x*), which provides operating power to the module. Installing the cFP-DIO-550 onto a powered backplane does not disrupt the operation of the bank.

To install the cFP-DIO-550, refer to Figure 2 and complete the following steps:

1. Align the captive screws on the cFP-DIO-550 with the holes on the backplane. The alignment keys on the cFP-DIO-550 prevent backward insertion.
2. Press firmly to seat the cFP-DIO-550 on the backplane.
3. Using a number 2 Phillips screwdriver with a shank of at least 64 mm (2.5 in.) length, tighten the captive screws to 1.1 N · m (10 lb · in.) of torque. The nylon coating on the screws prevents them from loosening.

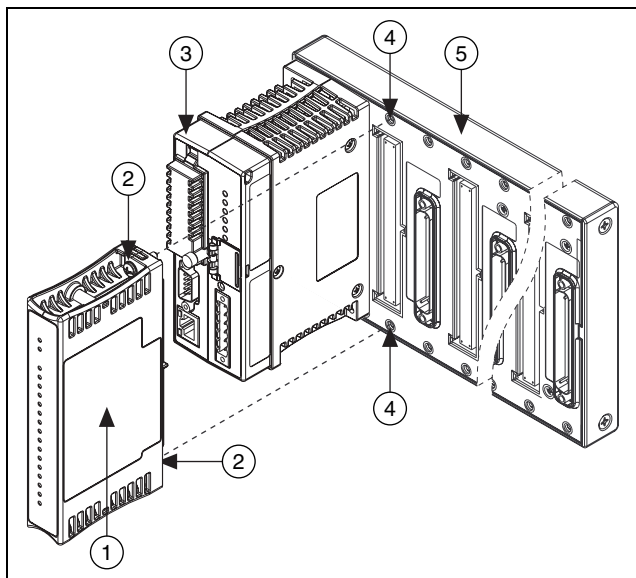

- | | |
|-------------------------|-----------------|
| 1 cFP I/O Module | 4 Screw Holes |
| 2 Captive Screws | 5 cFP Backplane |
| 3 cFP Controller Module | |

Figure 2. Installing the cFP-DIO-550

Wiring the [c]FP-DIO-550

The FP-TB-*x* terminal base has connections for each FP-DIO-550 input and output channel, and for an external power supply to power field devices. The cFP-CB-*x* connector block provides the same connections for the cFP-DIO-550.

Each input channel has two input terminals, IN+ and IN-. Each output channel has one output terminal, V_{OUT}, and one COM terminal. All eight output channels are referenced to the COM terminals. The C and COM terminals are all internally connected.

Connect the positive lead of the external power supply to both V terminals and the negative lead to both C terminals. Ensure that the current through each V terminal can never exceed 2 A.

Install a 2 A maximum, fast-acting fuse between the external power supply and the V terminals. The wiring diagrams in this document show fuses where appropriate.

Table 1. Input Terminal Assignments

Channel	Terminal Numbers	
	IN+	IN-
In 0	1	2
In 1	3	4
In 2	5	6
In 3	7	8
In 4	17	18
In 5	19	20
In 6	21	22
In 7	23	24

Table 2. Output Terminal Assignments

Channel	Terminal Numbers	
	V _{OUT}	COM
Out 0	9	10
Out 1	11	12
Out 2	13	14
Out 3	15	16
Out 4	25	26
Out 5	27	28
Out 6	29	30
Out 7	31	32

Digital Input

The [c]FP-DIO-550 has eight current-limited input channels with optical isolators. Each channel has two input terminals, IN+ and IN-. When the voltage across the IN+ and IN- terminals is at least 11 V, signal current flows through the input and turns on the optical isolator, and the channel is ON. The current-limiting circuitry limits the amount of current flow to 7 mA.

When the voltage across the IN+ and IN- terminals is less than 5 V, the channel is OFF. When the voltage is between 5 and 11 V, the channel may be ON or OFF.

The input channels are *floating*, which means that they do not share a common ground reference. Make sure that there is no more than 30 V difference between any two input terminals.

Figure 3 shows the input circuitry of a single channel.

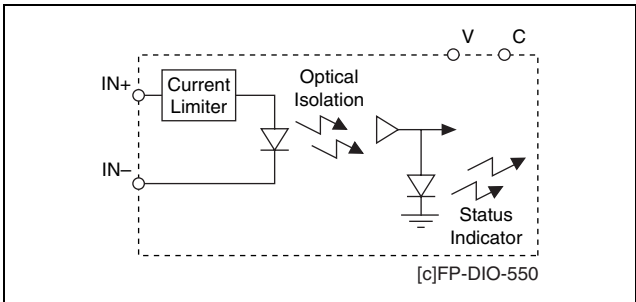

Figure 3. [c]FP-DIO-550 Input Circuit

The devices you connect to the [c]FP-DIO-550 should have OFF-state leakage currents of less than 300 μA to ensure that they do not cause false ON readings.

Digital Input Filter

Each input channel has a filter that can prevent electrical noise from causing false readings. In Measurement & Automation Explorer (MAX), you can select a value from 0 to 65,535 μs for the digital input filter on each channel. The filter rejects pulses that are 1 μs or more shorter than the length you select. If you select 0 μs , the filter is disabled.

Input Latching

In MAX, you can configure each input channel to operate in either standard mode or latch mode. In standard mode, the channel returns a value of TRUE when the input is high and FALSE when the input is low. In latch mode, the channel latches to one value when it detects a specific input signal state and retains that value until you reset the channel. The two latch modes are Latch TRUE on high and Latch FALSE on low. If the channel is in Latch TRUE on high mode, it returns TRUE when it detects a high input signal and continues to return TRUE until the channel is reset, regardless of subsequent changes to the input signal. If the channel is in Latch FALSE on low mode, it returns FALSE when it detects a low input signal and continues to return FALSE until the channel is reset. To unlatch and reset the channel, send the Reset Latch command.



Note If the input signal matches the value that the channel is configured to detect when you put the channel in one of the latch modes, the channel latches immediately. Similarly, if you attempt to reset the channel when the input signal is in the state that the channel is set to detect, the channel will not reset.

You can use input latching to detect short signal pulses that software polling might otherwise miss.

Connecting a Differential-Output Device to the [c]FP-DIO-550

You can connect a differential-output device to an input channel of the [c]FP-DIO-550. Connect the positive lead to the IN+ terminal of the channel and connect the negative lead to the IN- terminal of the channel. Refer to Figure 4.

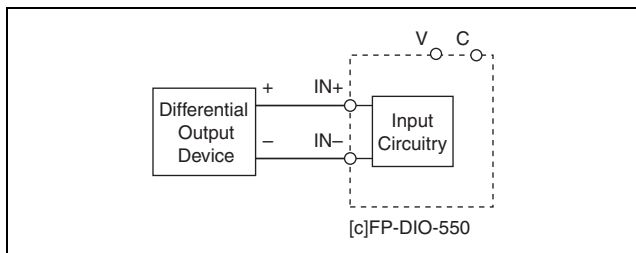

Figure 4. Connecting a Differential-Output Device to One Channel of the [c]FP-DIO-550

Connecting a Sinking-Output Device to the [c]FP-DIO-550

You can connect an externally powered sinking-output device to an input channel of the [c]FP-DIO-550. A sinking-output device provides a path to ground. Connect the positive terminal of the power supply to the IN+ terminal of the channel and connect the output terminal of the device to the IN- terminal of the channel. Refer to Figure 5.

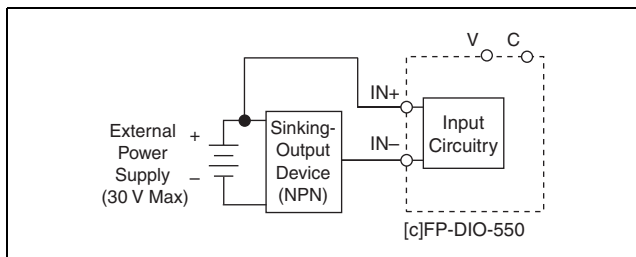

Figure 5. Connecting an Externally Powered Sinking-Output Device to One Channel of the [c]FP-DIO-550

Connecting a Sourcing-Output Device to the [c]FP-DIO-550

You can connect an externally powered sourcing-output device to an input channel of the [c]FP-DIO-550. A sourcing-output device provides a path to a voltage source. Connect the output terminal of the device to the IN+ terminal of the channel and connect the negative terminal of the external power supply to the IN- terminal of the channel. Refer to Figure 6.

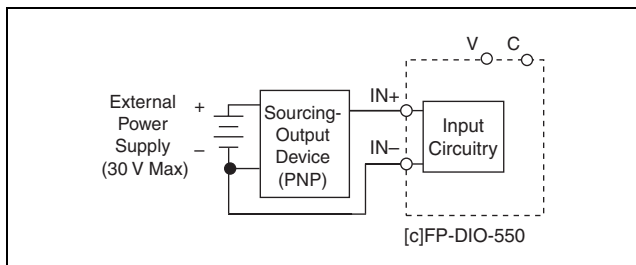

Figure 6. Connecting an Externally Powered Sourcing-Output Device to One Channel of the [c]FP-DIO-550

Digital Output Circuit

The [c]FP-DIO-550 digital output channels are optically isolated from the rest of the FieldPoint bank. The channels are *sourcing* outputs, which means that the output terminal provides a path to a voltage supply.

In the ON state, a transistor is turned on between the V terminal and the V_{OUT} terminal. In the OFF state, this transistor is turned off, allowing only a small leakage current to flow.

Ensure that the load on any channel does not draw more than 250 mA.



Caution Do not short-circuit outputs to C or COM terminals. Short circuits can damage the outputs. Check all wiring carefully before applying power.

In the ON state, the maximum effective resistance between the V_{OUT} terminal and the V terminal is 200 m Ω . This resistance causes a voltage drop between the external supply voltage and the output voltage. Table 3 lists the minimum output voltages based on the voltage provided by the external power supply.

Table 3. [c]FP-DIO-550 Output Voltages for 250 mA Current Flow

V	V_{OUT}
10	9.95
12	11.95
24	23.95
30	29.95

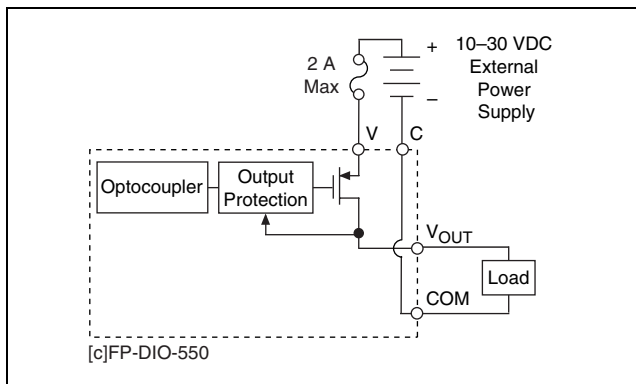

Figure 7. Digital Output Circuit

If the external power supply you are using does not provide one of the voltages in Table 3, use the following equation to calculate the actual voltage output.

$$\text{ActualOutput} = V_{ext} - (I_0 \times 0.20 \Omega)$$

where ActualOutput is the voltage sourced by V_{OUT}

V_{ext} is the voltage provided by the external power supply

I_0 is the current flow through the V_{OUT} terminal

Output Pattern Matching

Pattern match mode enables you to configure output channels to respond directly to specific patterns of states on the input channels. In MAX, you can configure each output channel to turn on or off if the input pattern occurs. Also, you can configure each output channel to latch on or off until it is reset or to update continually based on the input pattern.

The following table shows the four pattern match modes.

Table 4. Pattern Match Modes and How They Affect Channel Behavior

Pattern Match Mode	Behavior
Set High During Match	The output turns on when the input pattern is detected and turns off when the pattern is not detected.
Set Low During Match	The output turns off when the input pattern is detected and turns on when the pattern is not detected.
Latch High On Match	The output latches on when the input pattern is detected. The output stays on until it is cleared from software at which point it turns off until the input pattern is present again.
Latch Low On Match	The output latches off when the input pattern is detected. The output stays off until it is cleared from software at which point it turns on until the input pattern is present again.

To specify the input pattern you want to detect, you must enter the pattern mask and pattern value in MAX. The mask identifies the input channels included in the pattern, and the value specifies which state the inputs must be in for a positive match. The mask and the value are eight-bit binary numbers, and you must convert them to decimal before entering them in MAX. The eight bits correspond to the eight input channels. A 1 in bit position n in the mask means that input channel n is part of the pattern. A 0 in bit position n in the mask means that the channel is not part of the pattern. A 1 in bit position n in the pattern value means that input channel n must be on for a successful match. A 0 in bit position n in the pattern value means that input channel n must be off for a successful match.

For example, suppose you want output channel 2 to turn on when the following condition is true and turn off when the condition is not true: Input channel 7 is on, 5 is off, 2 is on, and 1 is off. The other input channels do not matter in this pattern. The following table shows the bits in this pattern mask.

Channel	7	6	5	4	3	2	1	0
Bit	1	0	1	0	0	1	1	0
Conversion	$\times 128$	$\times 64$	$\times 32$	$\times 16$	$\times 8$	$\times 4$	$\times 2$	$\times 1$

In this example, the binary mask 10100110 converts to 166.

The following table shows the bits in the pattern value.

Channel	7	6	5	4	3	2	1	0
Bit	1	0	0	0	0	1	0	0
Conversion	$\times 128$	$\times 64$	$\times 32$	$\times 16$	$\times 8$	$\times 4$	$\times 2$	$\times 1$

The binary value 10000100 converts to 132. To configure this example, set output channel 2 mode to Set High During Match. Set the Pattern Match Mask to 166. Set the Pattern Match Value to 132.

Protection for Inductive Loads

When an inductive load, such as a motor or relay, is connected to an output, a large counter-electromotive force may occur at switching time because of the energy stored in the inductive load. This *flyback voltage* can damage the output and the power supply.

It is best to limit flyback voltages by installing a flyback diode across an inductive load. Typically, you should mount the flyback diode within 18 in. of the load. Figure 8 shows one channel connected to an inductive load with a flyback diode.

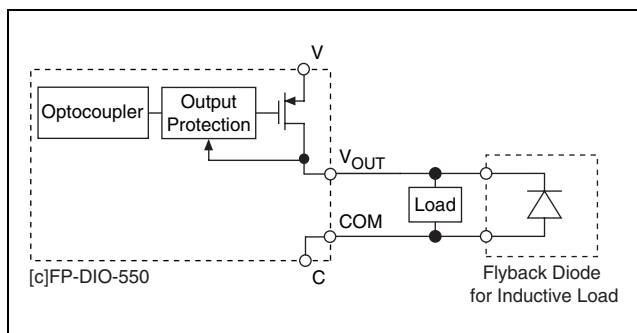

Figure 8. Digital Output Circuit (External Power Supply Not Shown)

The [c]FP-DIO-550 contains flyback diodes to prevent excessively high voltage from damaging the module. National Instruments still recommends using an external protection circuit across any inductive load.

Status Indicators

The [c]FP-DIO-550 has two green status LEDs, **POWER** and **READY**. After you insert the FP-DIO-550 into a terminal base or the cFP-DIO-550 into a backplane and apply power to the connected network module, the green **POWER** indicator lights and the [c]FP-DIO-550 informs the network module of its presence. When the network module recognizes the [c]FP-DIO-550, it sends initial configuration information to the [c]FP-DIO-550. After the [c]FP-DIO-550 receives this initial information, the green **READY** indicator lights and the module is in normal operating mode.

In addition to the green **POWER** and **READY** indicators, each channel has a numbered green status indicator that lights when the channel is in the ON state.

Isolation and Safety Guidelines



Caution Read the following information before attempting to connect the [c]FP-DIO-550 to any circuits that may contain hazardous voltages.

This section describes the isolation of the [c]FP-DIO-550 and its compliance with international safety standards. The field wiring connections are isolated from the backplane and the inter-module communication bus. The isolation barriers in the module provide 250 V_{rms} Measurement Category II continuous isolation, verified by 2,300 V_{rms}, 5 s dielectric withstand test. The [c]FP-DIO-550 provides *double insulation* (compliant with IEC 61010-1) for working voltages of 250 V_{rms}¹. Safety standards (such as those published by UL and IEC) require the use of double insulation between hazardous voltages and any human-accessible parts or circuits.

Never try to use any isolation product between human-accessible parts (such as DIN rails or monitoring stations) and circuits that can be at hazardous potentials under normal conditions, unless the product is specifically designed for such an application, as is the [c]FP-DIO-550.

¹ *Working voltage* is defined as the signal voltage plus the common-mode voltage. *Common-mode voltage* is the voltage of the module with respect to ground.

Even though the [c]FP-DIO-550 is designed to handle applications with hazardous potentials, follow these guidelines to ensure a safe total system:

- There is no isolation between channels on the [c]FP-DIO-550. If a hazardous voltage is present on any channel, all channels are considered hazardous. Make sure that all other devices and circuits connected to the module are properly insulated from human contact.
- Do *not* share the external supply voltages (the V and C terminals) with other devices (including other FieldPoint devices), unless those devices are isolated from human contact.
- For Compact FieldPoint, you *must* connect the protective earth (PE) ground terminal on the cFP-BP-*x* backplane to the system safety ground. The backplane PE ground terminal has the following symbol stamped beside it: . Connect the backplane PE ground terminal to the system safety ground using 14 AWG (1.6 mm) wire with a ring lug. Use the 5/16 in. panhead screw shipped with the backplane to secure the ring lug to the backplane PE ground terminal.
- As with any hazardous voltage wiring, make sure that all wiring and connections meet applicable electrical codes and commonsense practices. Mount terminal bases and backplanes in an area, position, or cabinet that prevents accidental or unauthorized access to wiring that carries hazardous voltages.
- Do *not* use the [c]FP-DIO-550 as the only isolating barrier between human contact and working voltages higher than 250 V_{rms}.
- Operate the [c]FP-DIO-550 only at or below Pollution Degree 2. Pollution Degree 2 means that only nonconductive pollution occurs in most cases. Occasionally, however, a temporary conductivity caused by condensation must be expected.
- Operate the [c]FP-DIO-550 at or below Measurement Category II. Measurement Category II is for measurements performed on circuits directly connected to the low-voltage installation. This category refers to local-level distribution, such as that provided by a standard wall outlet.

Safety Guidelines for Hazardous Locations

The [c]FP-DIO-550 is suitable for use in Class I, Division 2, Groups A, B, C, D, T4 hazardous locations; Class I, Zone 2, AEx nA IIC T4 and Ex nA IIC T4 hazardous locations; and nonhazardous locations only. Follow these guidelines if you are installing the [c]FP-DIO-550 in a potentially explosive environment. Failing to follow these guidelines may result in serious injury or death.



Caution Make sure that all products you use in hazardous locations are certified for such use. Refer to the product label or visit ni.com/certification, search by model number or product line, and click the appropriate link in the Certification column.



Caution Do *not* disconnect I/O-side wires or connectors unless power has been switched off or the area is known to be nonhazardous.



Caution Do *not* remove modules unless power has been switched off or the area is known to be nonhazardous.



Caution Substitution of components may impair suitability for Class I, Division 2.



Caution For Zone 2 applications, install the FieldPoint system in an enclosure rated to at least IP 54 as defined by IEC 60529 and EN 60529.



Caution For Zone 2 applications, install a protection device across the external power supply and the COM terminal. The device must prevent the external power supply voltage from exceeding 42 V if there is a transient overvoltage condition.

Special Conditions for Hazardous Locations Use in Europe

The [c]FP-DIO-550 has been evaluated as EEx nC IIC T4 equipment under DEMKO Certificate No. 03 ATEX 0251502X. Each module is marked Ex II 3G and is suitable for use in Zone 2 hazardous locations.

Specifications

These specifications are typical for -40 to 50 °C unless otherwise noted. Specifications are subject to change without notice.

Input Characteristics

Number of channels.....	8
Input type.....	Sinking, sourcing, or differential
Maximum input voltage.....	30 VDC
Digital logic levels	
OFF state.....	≤ 5 VDC
ON state.....	11–30 VDC
Input current.....	7 mA max
Input delay time.....	100 μ s max
Maximum reverse voltage.....	30 VDC

Output Characteristics

Number of channels.....	8
Output type.....	Sourcing
Supply voltage range (V_{ext}).....	10–30 V
Output voltage.....	$V_{ext} - (I_0 R_0)$
Output impedance (R_0).....	200 m Ω max
Continuous output current (I_0).....	250 mA max
Output protection.....	Short circuit

Physical Characteristics

Indicators.....	Green POWER and READY indicators, 16 green ON/OFF indicators
Weight	
FP-DIO-550.....	141 g (5.0 oz)
cFP-DIO-550.....	111 g (4.0 oz)

Power Requirements

Power from network module 600 mW

Isolation Voltage

Channel-to-ground isolation

Continuous 250 V_{rms}, Measurement
Category II

Dielectric withstand..... 2,300 V_{rms}, 5 s

Channel-to-channel isolation None

Environmental

FieldPoint modules are intended for indoor use only. For outdoor use, they must be mounted inside a sealed enclosure.

Operating temperature

Input voltage ≤ 25 V -40 to 70 °C

Input voltage ≤ 30 V -40 to 50 °C

Storage temperature -45 to 85 °C

Humidity 10 to 90% RH,
noncondensing

Maximum altitude..... 2,000 m; at higher altitudes
the isolation voltage ratings
must be lowered

Pollution Degree 2

Shock and Vibration

These specifications apply only to the cFP-DIO-550.

NI recommends Compact FieldPoint if your application is subject to shock and vibration.

Operating vibration, random

(IEC 60068-2-64)..... 10–500 Hz, 5 g_{rms}

Operating vibration, sinusoidal

(IEC 60068-2-6)..... 10–500 Hz, 5 g

Operating shock

(IEC 60068-2-27)..... 50 g, 3 ms half sine,
18 shocks at 6 orientations;
30 g, 11 ms half sine,
18 shocks at 6 orientations

Safety

This product is designed to meet the requirements of the following standards of safety for electrical equipment for measurement, control, and laboratory use:

- IEC 61010-1, EN-61010-1
- UL 61010-1, CAN/CSA-C22.2 No. 61010-1



Note For UL and other safety certifications, refer to the product label or visit ni.com/certification, search by model number or product line, and click the appropriate link in the Certification column.

Electromagnetic Compatibility

This product is designed to meet the requirements of the following standards of EMC for electrical equipment for measurement, control, and laboratory use:

- EN 61326 EMC requirements; Industrial Immunity
- EN 55011 Emissions; Group 1, Class A
- CE, C-Tick, ICES, and FCC Part 15 Emissions; Class A

CE Compliance

This product meets the essential requirements of applicable European Directives, as amended for CE marking, as follows:

- 73/23/EEC; Low-Voltage Directive (safety)
- 89/336/EEC; Electromagnetic Compatibility Directive (EMC)



Note Refer to the Declaration of Conformity (DoC) for this product for any additional regulatory compliance information. To obtain the DoC for this product, visit ni.com/certification, search by model number or product line, and click the appropriate link in the Certification column.

Waste Electrical and Electronic Equipment (WEEE)



EU Customers At the end of their life cycle, all products *must* be sent to a WEEE recycling center. For more information about WEEE recycling centers and National Instruments WEEE initiatives, visit ni.com/environment/weee.htm.

Mechanical Dimensions

Figure 9 shows the mechanical dimensions of the FP-DIO-550 installed on a terminal base. If you are using the cFP-DIO-550, refer to your Compact FieldPoint controller user manual for the dimensions and cabling clearance requirements of the Compact FieldPoint system.

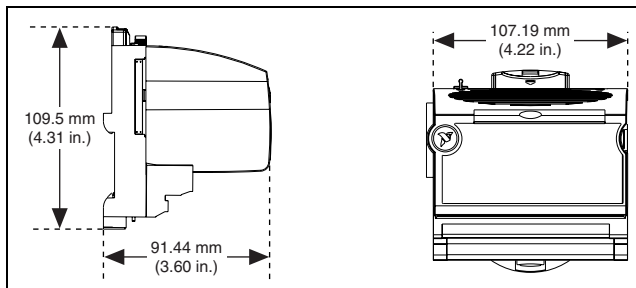

Figure 9. FP-DIO-550 Mechanical Dimensions

Where to Go for Support

For more information about setting up the FieldPoint system, refer to these National Instruments documents:

- FieldPoint network module user manual
- Other FieldPoint I/O module operating instructions
- FieldPoint terminal base and connector block operating instructions

Go to ni.com/support for the most current manuals, examples, and troubleshooting information.

National Instruments corporate headquarters is located at 11500 North Mopac Expressway, Austin, Texas, 78759-3504. National Instruments also has offices located around the world to help address your support needs. For telephone support in the United States, create your service request at ni.com/support and follow the calling instructions or dial 512 795 8248. For telephone support outside the United States, contact your local branch office:

Australia 1800 300 800, Austria 43 0 662 45 79 90 0,
Belgium 32 0 2 757 00 20, Brazil 55 11 3262 3599,
Canada 800 433 3488, China 86 21 6555 7838,
Czech Republic 420 224 235 774, Denmark 45 45 76 26 00,
Finland 385 0 9 725 725 11, France 33 0 1 48 14 24 24,

Germany 49 0 89 741 31 30, India 91 80 41190000,
Israel 972 0 3 6393737, Italy 39 02 413091,
Japan 81 3 5472 2970, Korea 82 02 3451 3400,
Lebanon 961 0 1 33 28 28, Malaysia 1800 887710,
Mexico 01 800 010 0793, Netherlands 31 0 348 433 466,
New Zealand 0800 553 322, Norway 47 0 66 90 76 60,
Poland 48 22 3390150, Portugal 351 210 311 210,
Russia 7 095 783 68 51, Singapore 1800 226 5886,
Slovenia 386 3 425 4200, South Africa 27 0 11 805 8197,
Spain 34 91 640 0085, Sweden 46 0 8 587 895 00,
Switzerland 41 56 200 51 51, Taiwan 886 02 2377 2222,
Thailand 662 278 6777, United Kingdom 44 0 1635 523545

National Instruments, NI, ni.com, and LabVIEW are trademarks of National Instruments Corporation. Refer to the *Terms of Use* section on ni.com/legal for more information about National Instruments trademarks. Other product and company names mentioned herein are trademarks or trade names of their respective companies. For patents covering National Instruments products, refer to the appropriate location: **Help»Patents** in your software, the `patents.txt` file on your CD, or ni.com/patents.

© 2004–2006 National Instruments Corp. All rights reserved.