

NI cRIO-9023

Intelligent Real-Time Embedded Controller for CompactRIO

This document describes how to set up and use the NI cRIO-9023 and contains specifications for the controller.

Figure 1. cRIO-9023 Front Panel

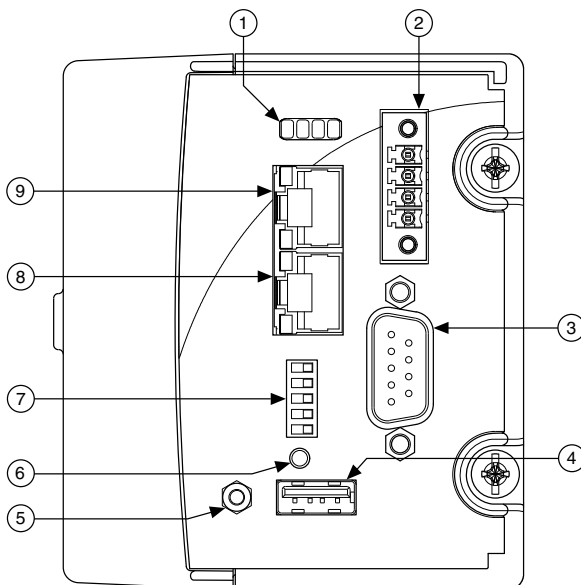

- | | |
|---------------------------|--------------------------|
| 1. LEDs | 6. Reset Button |
| 2. Power Connector | 7. DIP Switches |
| 3. RS-232 Serial Port | 8. RJ-45 Ethernet Port 1 |
| 4. USB Port | 9. RJ-45 Ethernet Port 2 |
| 5. USB Retention Standoff | |

Refer to the reconfigurable chassis documentation on ni.com/manuals for more information about the chassis. Refer to ni.com/gettingstarted for information about using the system after it is set up and configured. For information about software support, visit ni.com/info and enter the Info Code `swwsupport`.

Safety Guidelines



Caution Do not operate the cRIO-9023 in a manner not specified in this document. Product misuse can result in a hazard. You can compromise the safety protection built into the product if the product is damaged in any way. If the product is damaged, return it to NI for repair.

Safety Guidelines for Hazardous Locations

The cRIO-9023 is suitable for use in Class I, Division 2, Groups A, B, C, D, T4 hazardous locations; Class I, Zone 2, AEx nA IIC T4 and Ex nA IIC T4 hazardous locations; and nonhazardous locations only. Follow these guidelines if you are installing the cRIO-9023 in a potentially explosive environment. Not following these guidelines may result in serious injury or death.



Caution Do not disconnect the power supply wires and connectors from the controller unless power has been switched off.



Caution Do not install or remove the controller unless power has been switched off.



Caution Substitution of components may impair suitability for Class I, Division 2.



Caution For Division 2 and Zone 2 applications, install the system in an enclosure rated to at least IP54 as defined by IEC/EN 60079-15.

Special Conditions for Hazardous Locations Use in Europe and Internationally

The cRIO-9023 has been evaluated as Ex nA IIC T4 Gc equipment under DEMKO Certificate No. 07 ATEX 0626664X and is IECEx UL 14.0089X certified. Each cRIO-9023 is marked Ⓢ II 3G and is suitable for use in Zone 2 hazardous locations, in ambient temperatures of $-40\text{ }^{\circ}\text{C} \leq T_a \leq 70\text{ }^{\circ}\text{C}$. If you are using the cRIO-9023 in Gas Group IIC hazardous locations, you must use the device in an NI chassis that has been evaluated as Ex nC IIC T4, Ex IIC T4, Ex nA IIC T4, or Ex nL IIC T4 equipment.



Caution You must make sure that transient disturbances do not exceed 140% of the rated voltage.



Caution The system shall only be used in an area of not more than Pollution Degree 2, as defined in IEC 60664-1.



Caution The system shall be mounted in an ATEX/IECEx-certified enclosure with a minimum ingress protection rating of at least IP54 as defined in IEC/EN 60079-15.



Caution The enclosure must have a door or cover accessible only by the use of a tool.

Electromagnetic Compatibility Guidelines

This product was tested and complies with the regulatory requirements and limits for electromagnetic compatibility (EMC) stated in the product specifications. These requirements and limits provide reasonable protection against harmful interference when the product is operated in the intended operational electromagnetic environment.

This product is intended for use in industrial locations. However, harmful interference may occur in some installations, when the product is connected to a peripheral device or test object, or if the product is used in residential or commercial areas. To minimize interference with radio and television reception and prevent unacceptable performance degradation, install and use this product in strict accordance with the instructions in the product documentation.

Furthermore, any changes or modifications to the product not expressly approved by National Instruments could void your authority to operate it under your local regulatory rules.

Special Conditions for Marine Applications

Some products are Lloyd's Register (LR) Type Approved for marine (shipboard) applications. To verify Lloyd's Register certification for a product, visit ni.com/certification and search for the LR certificate, or look for the Lloyd's Register mark on the product.



Caution In order to meet the EMC requirements for marine applications, install the product in a shielded enclosure with shielded and/or filtered power and input/output ports. In addition, take precautions when designing, selecting, and installing measurement probes and cables to ensure that the desired EMC performance is attained.

Installing the cRIO-9023 on the Chassis

Complete the following steps to install the cRIO-9023 on the chassis.

1. Make sure that no power is connected to the cRIO-9023 or the chassis.
2. Align the cRIO-9023 with the chassis as shown in the following figure.

Figure 2. Installing the cRIO-9023 on the Chassis

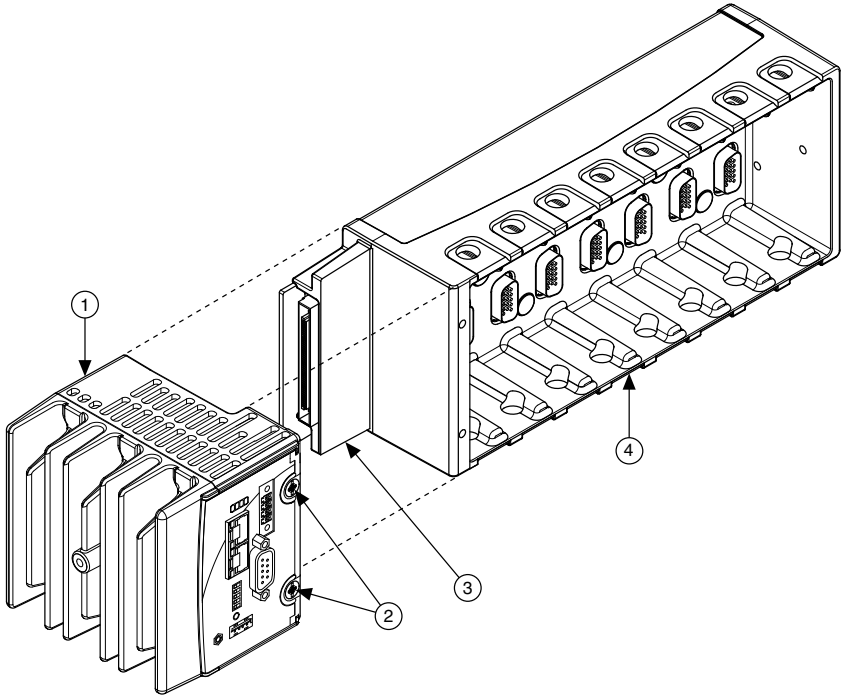

- | | |
|-------------------|----------------------|
| 1. Controller | 3. Chassis Connector |
| 2. Captive Screws | 4. Chassis |

3. Slide the cRIO-9023 onto the chassis connector. Press firmly to ensure the chassis connector and the cRIO-9023 connector are mated.
4. Using a Phillips #2 screwdriver, tighten the two captive screws on the front of the cRIO-9023 to 1.3 N · m (11.5 lb · in.) of torque.

Dimensions

The following figure shows the cRIO-9023 dimensions.

Figure 3. cRIO-9023 Top and Front Dimensions

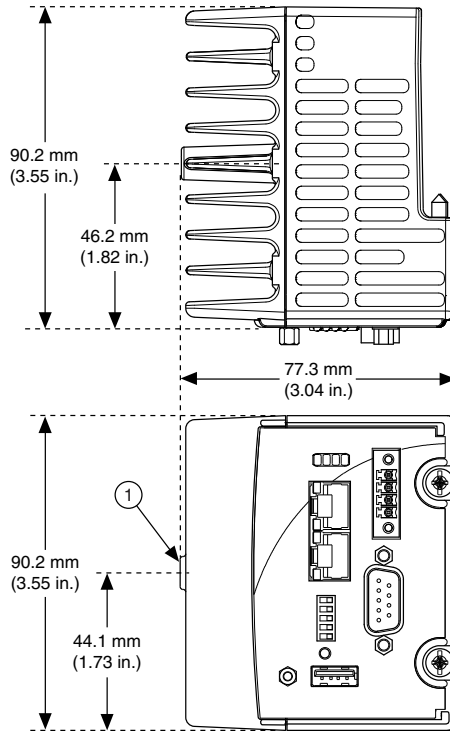

1. M4 Thread

Connecting the cRIO-9023 to a Network

Connect Ethernet port 1 on the cRIO-9023 to an Ethernet network using a standard Category 5 (CAT-5) or better Ethernet cable. The host computer communicates with the controller over a standard Ethernet connection. If neither the host computer nor the controller is connected to a network, you can connect the two directly.



Caution To prevent data loss and maintain the integrity of your Ethernet installation, do not use a cable longer than 100 m. If you are using 100 Mbps Ethernet, NI recommends using a CAT-5 or better shielded twisted-pair Ethernet cable.

Related Information

[Configuring IP Settings and Installing Software on the cRIO-9023](#) on page 7

[Ethernet Cabling](#) on page 18

Ethernet Port 2

To use Ethernet port 2, you must assign a static IP address to the port using Measurement & Automation Explorer (MAX). The IP address must be on a different subnet than the IP address of Ethernet port 1. You cannot use DHCP with Ethernet port 2. For more information about using Ethernet port 2, visit ni.com/info and enter the Info Code `dua1enet`.

Connecting the cRIO-9023 to Power



Caution You must install the cRIO-9023 on a chassis or use stand-alone mounting kit such as the NI 9908 or NI 9909 before wiring power to the cRIO-9023. Installing the cRIO-9023 while power is connected can damage the chassis.

The cRIO-9023 requires a 35 VDC external power supply. The cRIO-9023 filters and regulates the supplied power and provides power for the C Series modules. The cRIO-9023 has a primary power input, V1, and a secondary power input, V2. The cRIO-9023 draws power from the power supply with the higher voltage. The cRIO-9023 has one layer of reverse-voltage protection.

1. Ensure that your power supply is powered off.
2. Install the ferrite on the negative and positive leads of the power supply, as shown in the following figure.

Figure 4. Installing a Ferrite on the Power Leads

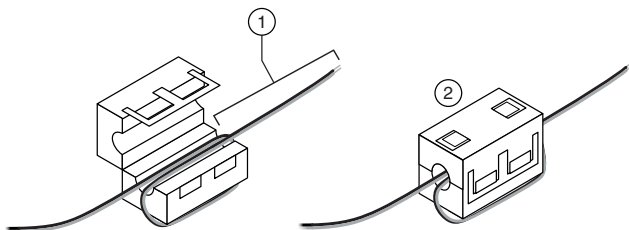

1. Pass the leads through the ferrite twice, leaving 50 mm to 75 mm (2 in. to 3 in.) between the ferrite and the end of the leads.
2. Close the ferrite around the leads.
3. Remove the power connector from the cRIO-9023.



Caution Do not tighten or loosen the terminal screws on the power connector while the cRIO-9023 is powered on.

4. Connect the primary power supply and optional secondary power supply to the power connector, as shown in the following figure.

Figure 5. cRIO-9023 Power Connections

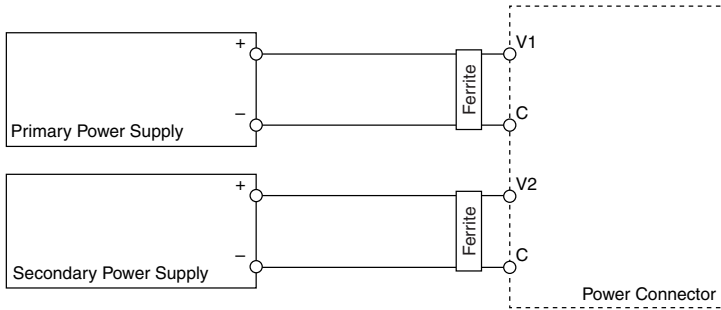

Note The C terminals are internally connected to each other.

5. Tighten the terminal screws on the power connector to $0.2 \text{ N} \cdot \text{m}$ to $0.25 \text{ N} \cdot \text{m}$ ($1.8 \text{ lb} \cdot \text{in.}$ to $2.2 \text{ lb} \cdot \text{in.}$) of torque.
6. Install the power connector on the front panel of the cRIO-9023.
7. Tighten the power connector screw flanges to $0.3 \text{ N} \cdot \text{m}$ to $0.4 \text{ N} \cdot \text{m}$ ($2.7 \text{ lb} \cdot \text{in.}$ to $3.5 \text{ lb} \cdot \text{in.}$) of torque.
8. Power on the primary power supply and optional secondary power supply.

Powering On the cRIO-9023

When you power on the cRIO-9023 for the first time, the device runs a power-on self test (POST). During the POST, the Power and Status LEDs turn on. When the Status LED turns off, the POST is complete.

Related Information

[LEDs](#) on page 11

Configuring IP Settings and Installing Software on the cRIO-9023

The cRIO-9023 initially boots into safe mode because there is no software installed. Complete the following steps to configure the cRIO-9023 and install software.

1. Launch MAX on the host computer.
2. Expand **Remote Systems** in the configuration tree and locate your system.
3. Select your target. MAX lists the system under the model number followed by the serial number, such as NI-CRIO-9023-1856AAA.



Tip If the cRIO-9023 is on a different subnet from the host computer, it does not initially appear under Remote Systems. Use the CONSOLE OUT switch to read the IP address of the cRIO-9023, and add it to Remote Systems in MAX.

The cRIO-9023 automatically attempts to connect to the network using DHCP. If DHCP is not available, the cRIO-9023 connects to the network with a link-local IP address with the form 169.254.x.x.

4. Select the **Network Settings** tab.
5. Enter a name for the RT target in the **Name** field.
6. Select settings for the RT target in the **IP Settings** section.



Note For information about configuring network settings, refer to the *MAX Remote Systems Help*.

7. Click **Apply**.
8. Click **Yes** to reboot the cRIO-9023 when prompted, or right-click the name under **Remote Systems** and select **Reboot**.
9. Expand the cRIO-9023 under **Remote Systems** and select **Software**.
10. Click **Add/Remove Software** in the toolbar to launch the LabVIEW Real-Time Software Wizard.
11. Install LabVIEW Real-Time software and device drivers on the controller.

The cRIO-9023 automatically reboots after the software installation. You can now program it using LabVIEW Real-Time. For information about configuring the cRIO-9023 to launch an embedded stand-alone application at startup, refer to the *LabVIEW Help*.



Note You must connect Ethernet port 1 to configure the cRIO-9023. You cannot configure the controller through Ethernet port 2.

RS-232 Serial Port

The cRIO-9023 has an RS-232 serial port to which you can connect devices such as displays or input devices. Use the Serial VIs to read from and write to the serial port. For more information about the Serial VIs, refer to the *LabVIEW Help*.

Figure 6. Serial Port Pinout

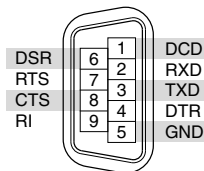

Internal Real-Time Clock

The cRIO-9023 system clock synchronizes with the internal high-precision real-time clock during startup. This synchronization provides timestamp data to the cRIO-9023. You can use the internal real-time clock to correct drift of the system clock.

Related Information

[Internal RTC](#) on page 15

USB Mass-Storage Devices

The cRIO-9023 supports common USB mass-storage devices such as USB Flash drives and USB-to-IDE adapters formatted with FAT16 and FAT32 file systems. LabVIEW maps USB devices to the U:, V:, W:, or X: drive, starting with the U: drive if it is available. You can connect multiple USB mass-storage devices to the cRIO-9023 if you use a USB hub. Refer to the *LabVIEW Help* for more information.



Note If the cRIO-9023 is not in a hazardous location, you can connect and disconnect USB devices without affecting operation.

DIP Switches

cRIO-9023 DIP switches are in the OFF position by default.

Figure 7. Controller DIP Switches

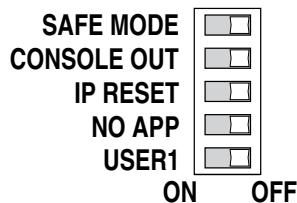

SAFE MODE Switch

The following table describes the ON and OFF states of the SAFE MODE switch.

Table 1. SAFE MODE Switch States

State	Description
ON	Essential services required for updating its configuration and installing software launch when the cRIO-9023 boots. Place this switch in the ON position if the software on the controller is corrupted or reformat the drive on the cRIO-9023.
OFF	The embedded LabVIEW Real-Time engine launches when the cRIO-9023 boots. Keep this switch in the OFF position during normal operation.



Note Even if the switch is in the OFF position, the cRIO-9023 automatically boots into safe mode if there is no software installed.

CONSOLE OUT Switch

The following table describes the ON and OFF states of the CONSOLE OUT switch.

Table 2. CONSOLE OUT Switch States

State	Description
ON	<p>Enables console out. You can read the IP address and firmware version of the cRIO-9023 using a serial-port terminal program. Connect the cRIO-9023 serial port to a computer using a null-modem cable and configure the serial-port terminal program with the following settings:</p> <ul style="list-style-type: none"> • 9,600 bits per second • Eight data bits • No parity • One stop bit • No flow control <p>The serial-port terminal program displays the IP address and firmware version of the cRIO-9023, and alerts you when you connect an unsupported USB device to the cRIO-9023.</p>
OFF	Disables console out. Keep this switch in the OFF position during normal operation.

IP RESET Switch

The following table describes the ON and OFF states of the IP RESET switch.

Table 3. IP RESET Switch States

State	Description
ON	Restore the cRIO-9023 to the default network settings. Reboot the cRIO-9023 to reset the IP address and other TCP/IP settings of the cRIO-9023 to the factory defaults.
OFF	Keep this switch in the OFF position during normal operation.

NO APP Switch

The following table describes the ON and OFF states of the NO APP switch.

Table 4. NO APP Switch States

State	Description
ON	Prevents a LabVIEW startup application from running when the cRIO-9023 powers on.
OFF	Runs an application when the cRIO-9023 powers on. If you already have an application configured to run when the cRIO-9023 powers on and you push the NO APP switch from ON to OFF, the startup application is automatically enabled.



Note If you want to permanently disable the application from running when the controller powers on, you must disable it in LabVIEW. For more information about automatically launching VIs when the controller powers on and disabling VIs from launching when the controller powers on, refer to the *LabVIEW Help*.

USER1 Switch

You can define the USER1 switch to meet the needs of your application. The following table lists the USER1 and FPGA LED descriptions. Use the RT Read Switch VI in your LabVIEW RT embedded VI to define the purpose of this switch in your embedded application. For more information about the RT Read Switch VI, refer to the *LabVIEW Help*.

RESET Button

Press the RESET button to reset the processor in the same manner as cycling power.

LEDs

The cRIO-9023 provides the following LEDs.

Figure 8. cRIO-9023 LEDs

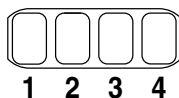

- | | |
|----------|-----------|
| 1. POWER | 3. STATUS |
| 2. FPGA | 4. USER1 |

POWER LED Indicators

The following table lists the POWER LED indicators.

Table 5. POWER LED Indicators

LED Color	LED Pattern	Indication
Green	Solid	The cRIO-9023 is powered from the V1 input.
Yellow	Solid	The cRIO-9023 is powered from the V2 input.
—	Off	The cRIO-9023 is powered off.

STATUS LED Indicators

The following table describes the STATUS LED indicators.

Table 6. Status LED Indications

LED Pattern	Indication
Blinks once and pauses	The cRIO-9023 is unconfigured. Refer to the <i>Measurement & Automation Explorer (MAX) Help</i> for information about configuring devices.
Blinks twice and pauses	An error can occur when an attempt to upgrade the software is interrupted. Reinstall software on the cRIO-9023. Refer to the <i>Measurement & Automation Explorer (MAX) Help</i> for information about installing software on the cRIO-9023.
Blinks three times and pauses	The cRIO-9023 is in a user-directed safe mode. Use the SAFE MODE DIP switch to turn off safe mode.
Blinks four times and pauses	The cRIO-9023 is in safe mode. The software has crashed twice without rebooting or cycling power between crashes.
Continuous blinks or solid	The cRIO-9023 has detected an unrecoverable error. Please contact NI.

User LEDs

You can define the USER1 and FPGA LEDs to meet the needs of your application. The following table lists the USER1 and FPGA LED descriptions.

Table 7. User LEDs

LED	LED Color	Description
USER1	Green/Yellow	Use LabVIEW Real-Time to define the USER1 LED with the RT LEDs VI. For more information about the RT LEDs VI, refer to the <i>LabVIEW Help</i> .
FPGA	Green/Yellow	Use the LabVIEW FPGA Module and NI-RIO Device Drivers software to define the FPGA LED. Use the FPGA LED to help debug your application or retrieve application status. Refer to the <i>LabVIEW Help</i> for information about programming this LED.

Resetting the Network Configuration of the Controller

If the cRIO-9023 cannot communicate with the network, you can use the IP RESET switch to manually restore the default network settings. Complete the following steps to restore the cRIO-9023 to the default network settings.

1. Move the IP RESET switch to the ON position.
2. Push the RESET button to cycle power to the cRIO-9023.

The STATUS LED flashes once, indicating that the cRIO-9023 IP address is unconfigured.

3. Move the IP RESET switch to the OFF position.

When you reboot the controller with the IP RESET switch in the ON position, the controller attempts to connect to the network using DHCP. If the controller is unable to initiate a DHCP connection, it connects to the network with a link-local IP address with the form `169.254.x.x`.

You can reconfigure the settings in MAX from a computer on the same subnet. Refer to the *Measurement & Automation Explorer Help* for more information about configuring the controller settings.



Note If the cRIO-9023 is restored to the factory network settings, the LabVIEW run-time engine does not load. You must reconfigure the network settings and restart the cRIO-9023 for the LabVIEW run-time engine to load.

Specifications

The following specifications are typical for the -40 °C to 70 °C operating temperature range unless otherwise noted.

CPU

Real-time processor	533 MHz Freescale MPC8347
---------------------	---------------------------

Network

Network Interface

Ethernet port 1	10BaseT and 100BaseTX Ethernet
-----------------	--------------------------------

Ethernet port 2	10BaseT and 100BaseTX Ethernet
-----------------	--------------------------------

Compatibility	IEEE 802.3
---------------	------------

Communication rates

Ethernet port 1	10 Mbps, 100 Mbps, auto-negotiated
-----------------	------------------------------------

Ethernet port 2	10 Mbps, 100 Mbps, auto-negotiated
-----------------	------------------------------------

Maximum cabling distance	100 m/segment
--------------------------	---------------

RS-232 DTE Serial Port

Baud rate	600 bps to 230,400 bps
-----------	------------------------

Data bits	5, 6, 7, 8
-----------	------------

Stop bits	1, 1.5, 2
-----------	-----------

Parity	Odd, even, mark, space, none
--------	------------------------------

Flow control	RTS/CTS, XON/XOFF, DTR/DSR, none
--------------	----------------------------------

USB Port

Maximum data rate	480 Mb/s
-------------------	----------

Maximum current	500 mA
-----------------	--------

Memory

Nonvolatile	2 GB
-------------	------

DRAM	256 MB
------	--------



Note For information about the life span of the nonvolatile memory and about best practices for using nonvolatile memory, go to ni.com/info and enter the Info Code SSDBP.

Internal RTC

Accuracy	200 ppm; 35 ppm at 25 °C
----------	--------------------------

Integrated Voltage Input Monitor

The integrated voltage input monitor underreports the voltage at the power connector by up to 400 mV because of voltage drops across internal circuits.

Power Requirements



Note You must power the cRIO-9023 using a National Electric Code (NEC) Class 2/UL listed ITS LPS power supply or mount the cRIO-9023 in a suitably-rated metal enclosure.

Recommended power supply	55 W secondary, 35 VDC maximum
--------------------------	--------------------------------

Power consumption

cRIO-9023 only	17 W
----------------	------

cRIO-9023 supplying power to eight C Series modules	35 W
---	------

Voltage requirement

On powerup	9 V to 35 V
------------	-------------

After powerup	6 V to 35 V
---------------	-------------



Note The cRIO-9023 is guaranteed to power up when 9 V is applied to V and C. After powerup, it can operate on as little as 6 V.

Physical Characteristics

If you need to clean the controller, wipe it with a dry towel.

Screw-terminal wiring

Gauge	0.33 mm ² to 2.1 mm ² (22 AWG to 14 AWG) copper conductor wire
-------	--

Wire strip length	6 mm (0.24 in.) of insulation stripped from the end
-------------------	---

Temperature rating	85 °C
--------------------	-------

Torque for screw terminals	0.2 N · m to 0.25 N · m (1.8 lb · in. to 2.2 lb · in.)
----------------------------	--

Wires per screw terminal	One wire per screw terminal
--------------------------	-----------------------------

Connector securement

Securement type	Screw flanges provided
Torque for screw flanges	0.3 N · m to 0.4 N · m (2.7 lb · in. to 3.5 lb · in.)
Weight	609 g (21.5 oz)

Environmental

Temperature (IEC 60068-2-1 and IEC 60068-2-2)

Operating	-40 °C to 70 °C
Storage	-40 °C to 85 °C



Caution Failure to follow the mounting instructions in the user manual can cause temperature derating. Visit ni.com/info and enter Info Code `criomounting` for more information about mounting configurations and temperature derating.

Ingress protection	IP20
Operating humidity (IEC 60068-2-56)	10% RH to 90% RH, noncondensing
Storage humidity (IEC 60068-2-56)	5% RH to 95% RH, noncondensing
Pollution Degree (IEC 60664)	2
Maximum altitude	5,000 m

Indoor use only.

Shock and Vibration

To meet these specifications for shock and vibration, you must panel mount or wall mount the cRIO-9023 system, affix ferrules to the ends of all terminal wires, install a strain relief on the power cable, and install tie wraps on the Ethernet and power cables. You can order the NI 9979 strain-relief kit for the power cable. For information about using the USB port in high shock and vibration environments, contact NI.

Operating vibration

Random (IEC 60068-2-64)	5 g _{rms} , 10 Hz to 500 Hz
Sinusoidal (IEC 60068-2-6)	5 g, 10 Hz to 500 Hz
Operating shock (IEC 60068-2-27)	30 g, 11 ms half sine; 50 g, 3 ms half sine; 18 shocks at 6 orientations

Safety Voltages

Connect only voltages that are within these limits.

V-to-C	35 V maximum, Measurement Category 1
--------	--------------------------------------

Measurement Category I is for measurements performed on circuits not directly connected to the electrical distribution system referred to as MAINS voltage. MAINS is a hazardous live electrical supply system that powers equipment. This category is for measurements of voltages from specially protected secondary circuits. Such voltage measurements include signal levels, special equipment, limited-energy parts of equipment, circuits powered by regulated low-voltage sources, and electronics.



Caution Do not connect to signals or use for measurements within Measurement Categories II, III, or IV.

Safety and Hazardous Locations Standards

This product is designed to meet the requirements of the following electrical equipment safety standards for measurement, control, and laboratory use:

- IEC 61010-1, EN 61010-1
- UL 61010-1, CSA 61010-1
- EN 60079-0:2012, EN 60079-15:2010
- IEC 60079-0: Ed 6, IEC 60079-15; Ed 4
- UL 60079-0; Ed 5, UL 60079-15; Ed 3
- CSA 60079-0:2011, CSA 60079-15:2012



Note For UL and other safety certifications, refer to the product label or the [Online Product Certification](#) section.

Electromagnetic Compatibility

This product meets the requirements of the following EMC standards for electrical equipment for measurement, control, and laboratory use:

- EN 61326 (IEC 61326): Class A emissions; Industrial immunity
- EN 55011 (CISPR 11): Group 1, Class A emissions
- AS/NZS CISPR 11: Group 1, Class A emissions
- FCC 47 CFR Part 15B: Class A emissions
- ICES-001: Class A emissions



Note For the standards applied to assess the EMC of this product, refer to the [Online Product Certification](#) section.



Note For EMC compliance, operate this product according to the documentation.

CE Compliance

This product meets the essential requirements of applicable European Directives, as follows:

- 2014/35/EU; Low-Voltage Directive (safety)
- 2014/30/EU; Electromagnetic Compatibility Directive (EMC)
- 94/9/EC; Potentially Explosive Atmospheres (ATEX)

Online Product Certification

Refer to the product Declaration of Conformity (DoC) for additional regulatory compliance information. To obtain product certifications and the DoC for this product, visit ni.com/certification, search by model number or product line, and click the appropriate link in the Certification column.

Environmental Management

NI is committed to designing and manufacturing products in an environmentally responsible manner. NI recognizes that eliminating certain hazardous substances from our products is beneficial to the environment and to NI customers.

For additional environmental information, refer to the *Minimize Our Environmental Impact* web page at ni.com/environment. This page contains the environmental regulations and directives with which NI complies, as well as other environmental information not included in this document.

Waste Electrical and Electronic Equipment (WEEE)



EU Customers This symbol indicates that waste products should be disposed of separately from municipal household waste according to WEEE Directive 2002/96/EC of the European Parliament and the Council on waste electrical and electronic equipment (WEEE). All products at the end of their life cycle must be sent to a WEEE collection and recycling center. Proper WEEE disposal reduces environmental impact and the risk to human health due to potentially hazardous substances used in such equipment. Your cooperation in proper WEEE disposal will contribute to the effective usage of natural resources. For information about the available collection and recycling scheme in a particular country, go to ni.com/environment/weee.

电子信息产品污染控制管理办法（中国 RoHS）



中国客户 National Instruments 符合中国电子信息产品中限制使用某些有害物质指令 (RoHS)。关于 National Instruments 中国 RoHS 合规性信息，请登录 ni.com/environment/rohs_china。(For information about China RoHS compliance, go to ni.com/environment/rohs_china.)

Ethernet Cabling

The following table shows the standard Ethernet cable wiring connections.

Table 8. Ethernet Cable Wiring Connections

Pin	Connector 1	Connector 2
1	white/orange	white/orange
2	orange	orange
3	white/green	white/green
4	blue	blue
5	white/blue	white/blue
6	green	green
7	white/brown	white/brown
8	brown	brown

Figure 9. Ethernet Connector Pinout

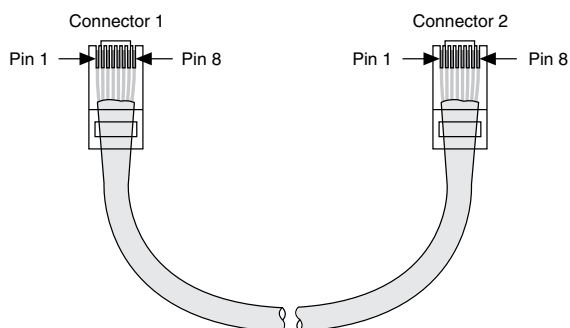

Worldwide Support and Services

The NI website is your complete resource for technical support. At ni.com/support, you have access to everything from troubleshooting and application development self-help resources to email and phone assistance from NI Application Engineers.

Visit ni.com/services for NI Factory Installation Services, repairs, extended warranty, and other services.

Visit ni.com/register to register your NI product. Product registration facilitates technical support and ensures that you receive important information updates from NI.

A Declaration of Conformity (DoC) is our claim of compliance with the Council of the European Communities using the manufacturer's declaration of conformity. This system

affords the user protection for electromagnetic compatibility (EMC) and product safety. You can obtain the DoC for your product by visiting ni.com/certification. If your product supports calibration, you can obtain the calibration certificate for your product at ni.com/calibration.

NI corporate headquarters is located at 11500 North Mopac Expressway, Austin, Texas, 78759-3504. NI also has offices located around the world. For telephone support in the United States, create your service request at ni.com/support or dial 1 866 ASK MYNI (275 6964). For telephone support outside the United States, visit the *Worldwide Offices* section of ni.com/global to access the branch office websites, which provide up-to-date contact information, support phone numbers, email addresses, and current events.

Refer to the *NI Trademarks and Logo Guidelines* at ni.com/trademarks for information on NI trademarks. Other product and company names mentioned herein are trademarks or trade names of their respective companies. For patents covering NI products/technology, refer to the appropriate location: **Help»Patents** in your software, the `patents.txt` file on your media, or the *National Instruments Patent Notice* at ni.com/patents. You can find information about end-user license agreements (EULAs) and third-party legal notices in the readme file for your NI product. Refer to the *Export Compliance Information* at ni.com/legal/export-compliance for the NI global trade compliance policy and how to obtain relevant HTS codes, ECCNs, and other import/export data. NI MAKES NO EXPRESS OR IMPLIED WARRANTIES AS TO THE ACCURACY OF THE INFORMATION CONTAINED HEREIN AND SHALL NOT BE LIABLE FOR ANY ERRORS. U.S. Government Customers: The data contained in this manual was developed at private expense and is subject to the applicable limited rights and restricted data rights as set forth in FAR 52.227-14, DFAR 252.227-7014, and DFAR 252.227-7015.

© 2009—2015 National Instruments. All rights reserved.

375489D-01 Oct15