

# FieldPoint™ Operating Instructions

## cFP-DI-304

### 32-Channel, 24 VDC Sinking Digital Input Module

These operating instructions describe how to install and use the cFP-DI-304 digital input module. For information about configuring and accessing the cFP-DI-304 over a network, refer to the user manual for the FieldPoint network module you are using.

## Features

---

The cFP-DI-304 is a FieldPoint digital input module with the following features:

- 32 sinking digital input channels
- Compatible with 24 VDC sourcing-output devices
- Inputs protected up to 30 VDC (up to 60 VDC on up to eight channels)
- 250 V<sub>rms</sub> CAT II continuous channel-to-ground isolation, verified by 2,300 V<sub>rms</sub>, 5 s dielectric withstand test
- On/off LED indicators
- Hot swappable

## Installing the cFP-DI-304

---

The cFP-DI-304 mounts on a Compact FieldPoint backplane (cFP-BP-*x*), which provides operating power to the module. Installing the cFP-DI-304 onto a powered backplane does not disrupt the operation of the FieldPoint bank.

To install the cFP-DI-304, refer to Figure 1 and complete the following steps:

1. Align the captive screws on the cFP-DI-304 with the holes on the backplane. The alignment keys on the cFP-DI-304 prevent backward insertion.
2. Press firmly to seat the cFP-DI-304 on the backplane.

- Using a number 2 Phillips screwdriver with a shank of at least 64 mm (2.5 in.) length, tighten the captive screws to 1.1 N · m (10 lb · in.) of torque. The nylon coating on the screws prevents them from loosening.

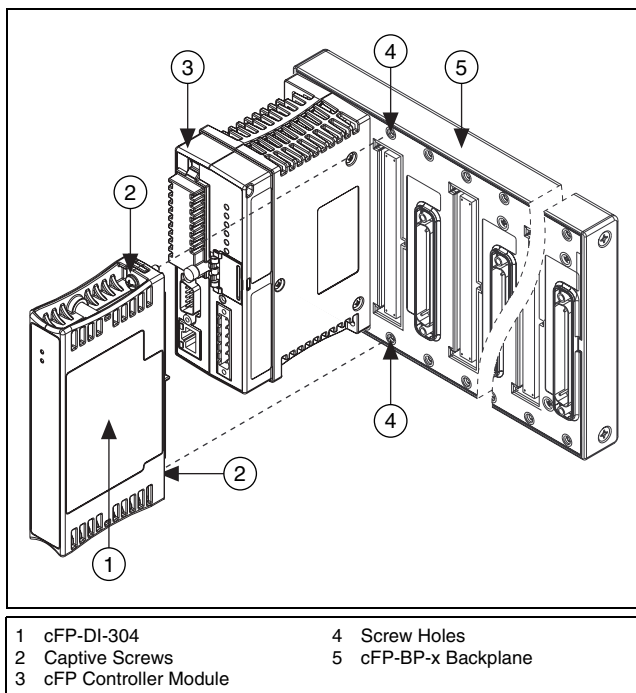

**Figure 1.** Installing the cFP-DI-304

## Mounting the System Upright

To ensure maximum cooling efficiency, mount the Compact FieldPoint system so that the I/O module vents are at the top and bottom as shown in Figure 2.

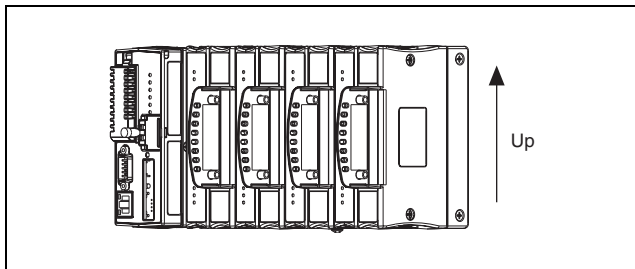

**Figure 2.** Mounting the System Upright

## Wiring the cFP-DI-304

The cFP-CB-1 has connections for each of the 32 input channels. You can use the cFP-CB-3, but it has connections for only 16 channels. Each channel has one input terminal,  $V_{IN}$ .

Table 1 lists the  $V_{IN}$  terminal assignment for each channel.

**Table 1.** Terminal Assignments

Channel	$V_{IN}$ Terminal
0	1
1	2
2	3
3	4
4	5
5	6
6	7
7	8
8	9
9	10
10	11
11	12
12	13
13	14
14	15

**Table 1.** Terminal Assignments (Continued)

Channel	V <sub>IN</sub> Terminal
15	16
16	17
17	18
18	19
19	20
20	21
21	22
22	23
23	24
24	25
25	26
26	27
27	28
28	29
29	30
30	31
31	32

You can wire each channel for use with a *sourcing-output* device. A sourcing-output device provides a path to a voltage source.

Figure 3 shows how to connect a sourcing-output device to one channel of the cFP-DI-304.

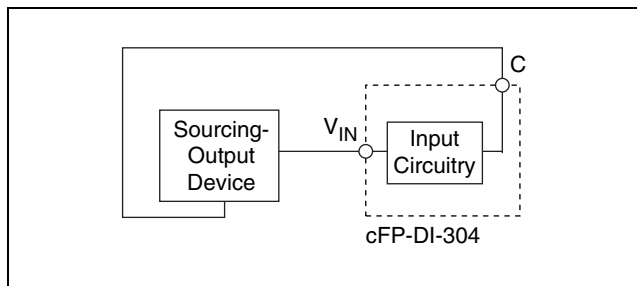
**Figure 3.** Sourcing-Output Device Connected to One Channel



**Note** You *must* ground all connected devices to the C terminals.

## Digital Input Circuitry

---

The cFP-DI-304 has 32 input channels. You can connect a voltage signal to each channel. All 32 input channels share a common ground reference that is isolated from other modules in the FieldPoint system.

When you apply a voltage above 10 V to a  $V_{IN}$  terminal, current flows through that terminal and the channel is ON. When you apply a voltage below 5 V to a  $V_{IN}$  terminal, the channel is OFF. When you apply a voltage between 5 and 10 V, the channel may be ON or OFF.

The cFP-DI-304 has *sinking* inputs, which means that current flows through the  $V_{IN}$  terminal to the input circuitry. The inputs are compatible with sourcing-output devices capable of sourcing or driving current from a positive supply voltage to common. A sensor is an example of a sourcing-output device.

Make sure that devices you connect to the cFP-DI-304 have OFF state leakage currents of less than 150  $\mu\text{A}$  to ensure that they do not provide false ON state readings to the cFP-DI-304.

## Status Indicators

---

The cFP-DI-304 has two green status LEDs, **POWER** and **READY**. After you insert the cFP-DI-304 into a backplane and apply power to the connected network module, the green **POWER** indicator lights and the cFP-DI-304 informs the network module of its presence. When the network module recognizes the cFP-DI-304, it sends initial configuration information to the cFP-DI-304. After the cFP-DI-304 receives this initial information, the green **READY** indicator lights and the module is in normal operating mode.

In addition to the **POWER** and **READY** lights, each channel has a numbered green status indicator that lights when the channel is in the ON state.

# Upgrading the FieldPoint Firmware

---

You may need to upgrade the FieldPoint firmware when you add new I/O modules to the FieldPoint system. For information about determining which firmware you need and how to upgrade your firmware, go to [ni.com/info](http://ni.com/info) and enter `fpmatrix`.

## Isolation and Safety Guidelines

---



**Caution** Read the following information before attempting to connect the cFP-DI-304 to any circuits that may contain *hazardous voltages*.<sup>1</sup>

This section describes the isolation of the cFP-DI-304 and its compliance with international safety standards. The field wiring connections are isolated from the backplane and the inter-module communication bus. The isolation barriers in the module provide 250 V<sub>rms</sub> Measurement Category II continuous channel-to-backplane and channel-to-ground isolation, verified by a 2,300 V<sub>rms</sub>, 5 s dielectric withstand test.<sup>2</sup> The cFP-DI-304 provides *double insulation* compliant with IEC 61010-1 for working voltages of 250 V<sub>rms</sub>.<sup>3</sup> Safety standards (such as those published by UL and IEC) require the use of double insulation between hazardous voltages and any human-accessible parts or circuits.

*Never* try to use any isolation product between human-accessible parts (such as DIN rails or monitoring stations) and circuits that can be at hazardous potentials under normal conditions, unless the product is specifically designed for such an application, as is the cFP-DI-304.

---

<sup>1</sup> A hazardous voltage is a voltage greater than 42.4 V<sub>peak</sub> or 60 VDC. When a hazardous voltage is present on any channel, all of the channels must be considered to be carrying hazardous voltages. Ensure that all circuits connected to the module are inaccessible to human touch.

<sup>2</sup> Refer to the [Safety Isolation Voltage](#) section for more information about isolation on the cFP-DI-304.

<sup>3</sup> *Working voltage* is defined as the signal voltage plus the common-mode voltage. *Common-mode voltage* is the voltage of the module with respect to ground.

Even though the cFP-DI-304 is designed to handle applications with hazardous potentials, follow these guidelines to ensure a safe total system:

- There is no isolation between channels on the cFP-DI-304. If a hazardous voltage is present on any channel, all channels are considered hazardous. Make sure that all other devices and circuits connected to the module are properly insulated from human contact.
- Do *not* share the external supply voltages (the V and C terminals) with other devices, including other FieldPoint devices, unless those devices are isolated from human contact.
- For Compact FieldPoint, you *must* connect the protective earth (PE) ground terminal on the cFP-BP-*x* backplane to the system safety ground. The backplane PE ground terminal has the following symbol stamped beside it:  $\oplus$ . Connect the backplane PE ground terminal to the system safety ground using 14 AWG (1.6 mm) wire with a ring lug. Use the 5/16 in. panhead screw shipped with the backplane to secure the ring lug to the backplane PE ground terminal.
- As with any hazardous voltage wiring, make sure that all wiring and connections meet applicable electrical codes and commonsense practices. Mount terminal bases and backplanes in an area, position, or cabinet that prevents accidental or unauthorized access to wiring that carries hazardous voltages.
- Do *not* use the cFP-DI-304 as the only isolating barrier between human contact and working voltages higher than  $250 V_{\text{rms}}$ .
- Operate the cFP-DI-304 only at or below Pollution Degree 2. Pollution Degree 2 means that only nonconductive pollution occurs in most cases. Occasionally, however, a temporary conductivity caused by condensation must be expected.
- Operate the cFP-DI-304 at or below Measurement Category II. Measurement Category II is for measurements performed on circuits directly connected to the low-voltage installation. This category refers to local-level distribution, such as that provided by a standard wall outlet.

## Safety Guidelines for Hazardous Locations

The cFP-DI-304 is suitable for use in Class I, Division 2, Groups A, B, C, and D hazardous locations; Class I, Zone 2, AEx nC IIC T4 and Ex nC IIC T4 hazardous locations; and nonhazardous locations only. Follow these guidelines if you are installing the

cFP-DI-304 in a potentially explosive environment. Failing to follow these guidelines may result in serious injury or death.



**Caution** Do *not* disconnect I/O-side wires or connectors unless power has been switched off or the area is known to be nonhazardous.



**Caution** Do *not* remove modules unless power has been switched off or the area is known to be nonhazardous.



**Caution** Substitution of components may impair suitability for Class I, Division 2.



**Caution** For Zone 2 applications, install the Compact FieldPoint system in an enclosure rated to at least IP 54 as defined by IEC 60529 and EN 60529.

## Special Conditions for Safe Use in Europe

This equipment has been evaluated as EEx nC IIC T4 equipment under DEMKO Certificate No. 03 ATEX 0251502X. Each module is marked  $\text{Ex}$  II 3G and is suitable for use in Zone 2 hazardous locations.



**Caution** For Zone 2 applications, connected signals must be within the following limits:

Capacitance ..... 0.2  $\mu\text{F}$  max

## Safety Guidelines for Hazardous Voltages

If *hazardous voltages* are connected to the module, take the following precautions. A hazardous voltage is a voltage greater than 42.4 V<sub>peak</sub> or 60 VDC to earth ground.



**Caution** Ensure that hazardous voltage wiring is performed only by qualified personnel adhering to local electrical standards.



**Caution** Do *not* mix hazardous voltage circuits and human-accessible circuits on the same module.



**Caution** Make sure that devices and circuits connected to the module are properly insulated from human contact.



**Caution** When terminals on the connector block are live with hazardous voltages, make sure that the terminals are *not* accessible.

# Specifications

---

These specifications are typical for the range  $-40$  to  $70$  °C unless otherwise noted. Specifications are subject to change in future revisions.

## Input Characteristics

Number of channels .....	32
Input voltage .....	0–30 VDC
Input type .....	Sinking
Digital logic levels	

### OFF state

Input voltage .....	$\leq 5$ V
Input current.....	$\leq 150$ $\mu$ A

### ON state

Input voltage .....	$\geq 10$ V
Input current.....	$\geq 330$ $\mu$ A

### Hysteresis

Input voltage .....	2 V min
Input current.....	60 $\mu$ A min

Input impedance.....	30 k $\Omega$ $\pm 6\%$
----------------------	-------------------------

## I/O protection

### Input voltage

Eight channels.....	60 VDC/channel max
32 channels .....	30 VDC/channel max

### Reverse-biased voltage

Eight channels.....	–60 VDC/channel max
32 channels .....	–30 VDC/channel max

## Physical Characteristics

Indicators .....	Green <b>POWER</b> and <b>READY</b> indicators, 32 green input state indicators
Weight.....	193 g (6.81 oz)

## Power Requirements

Power from network module .....	1 W
---------------------------------	-----

## Safety Isolation Voltage

Isolation voltage is verified by a dielectric withstand test.

### Channel to ground

Continuous .....	250 V <sub>rms</sub>
Withstand.....	2,300 V <sub>rms</sub> , 5 s max

### Channel to backplane

Continuous .....	250 V <sub>rms</sub>
Withstand.....	2,300 V <sub>rms</sub> , 5 s max

Channel to channel ..... None

## Environmental

FieldPoint modules are intended for indoor use only. For outdoor use, they must be mounted inside a sealed enclosure.

### Operating temperature

With system mounted upright <sup>1</sup> .....	-40 to 70 °C
With system in other orientations.....	-40 to 65 °C

Storage temperature ..... -55 to 85 °C

Humidity ..... 10 to 90% RH,  
noncondensing

Maximum altitude..... 2,000 m; at higher altitudes  
the isolation voltage ratings  
must be lowered.

Pollution Degree ..... 2

## Shock and Vibration

Operating vibration, random  
(IEC 60068-2-64)..... 10–500 Hz, 5 g<sub>rms</sub>

Operating vibration, sinusoidal  
(IEC 60068-2-6)..... 10–500 Hz, 5 g

Operating shock  
(IEC 60068-2-27)..... 50 g, 3 ms half sine,  
18 shocks at 6 orientations;  
30 g, 11 ms half sine,  
18 shocks at 6 orientations

---

<sup>1</sup> Refer to Figure 2 for the proper system orientation.

## Safety Standards

This product is designed to meet the requirements of the following standards of safety for electrical equipment for measurement, control, and laboratory use:

- EN 61010-1, IEC 61010-1
- UL 61010-1
- CAN/CSA-22.2 No. 61010-1



**Note** For UL and other safety certifications, refer to the product label, or visit [ni.com/certification](http://ni.com/certification), search by model number or product line, and click the appropriate link in the Certification column.

## Electromagnetic Compatibility

Emissions.....	EN 55011 Class A at 10 m; FCC Part 15A above 1 GHz
Immunity.....	EN 61326:1997 + A2:2001, Table 1

CE, C-Tick, and FCC Part 15 (Class A) Compliant



**Note** For EMC compliance, you must operate this device with shielded cabling.

## CE Compliance

This product meets the essential requirements of applicable European Directives, as amended for CE marking, as follows:

Low-Voltage Directive (safety).....	73/23/EEC
Electromagnetic Compatibility Directive (EMC) .....	89/336/EEC



**Note** Refer to the Declaration of Conformity (DoC) for this product for any additional regulatory compliance information. To obtain the DoC for this product, visit [ni.com/certification](http://ni.com/certification), search by model number or product line, and click the appropriate link in the Certification column.

# Where to Go for Support

---

For more information about setting up the FieldPoint system, refer to these National Instruments documents:

- FieldPoint network module user manual
- Other FieldPoint I/O module operating instructions
- FieldPoint terminal base and connector block operating instructions

Go to [ni.com/support](http://ni.com/support) for the most current manuals, examples, and troubleshooting information.

National Instruments corporate headquarters is located at 11500 North Mopac Expressway, Austin, Texas, 78759-3504. National Instruments also has offices located around the world to help address your support needs. For telephone support in the United States, create your service request at [ni.com/support](http://ni.com/support) and follow the calling instructions or dial 512 795 8248. For telephone support outside the United States, contact your local branch office:

Australia 1800 300 800, Austria 43 0 662 45 79 90 0,  
Belgium 32 0 2 757 00 20, Brazil 55 11 3262 3599,  
Canada 800 433 3488, China 86 21 6555 7838,  
Czech Republic 420 224 235 774, Denmark 45 45 76 26 00,  
Finland 385 0 9 725 725 11, France 33 0 1 48 14 24 24,  
Germany 49 0 89 741 31 30, India 91 80 51190000,  
Israel 972 0 3 6393737, Italy 39 02 413091,  
Japan 81 3 5472 2970, Korea 82 02 3451 3400,  
Lebanon 961 0 1 33 28 28, Malaysia 1800 887710,  
Mexico 01 800 010 0793, Netherlands 31 0 348 433 466,  
New Zealand 0800 553 322, Norway 47 0 66 90 76 60,  
Poland 48 22 3390150, Portugal 351 210 311 210,  
Russia 7 095 783 68 51, Singapore 1800 226 5886,  
Slovenia 386 3 425 4200, South Africa 27 0 11 805 8197,  
Spain 34 91 640 0085, Sweden 46 0 8 587 895 00,  
Switzerland 41 56 200 51 51, Taiwan 886 02 2377 2222,  
Thailand 662 278 6777, United Kingdom 44 0 1635 523545

National Instruments, NI, ni.com, and LabVIEW are trademarks of National Instruments Corporation. Refer to the *Terms of Use* section on [ni.com/legal](http://ni.com/legal) for more information about National Instruments trademarks. Other product and company names mentioned herein are trademarks or trade names of their respective companies. For patents covering National Instruments products, refer to the appropriate location: **Help»Patents** in your software, the `patents.txt` file on your CD, or [ni.com/patents](http://ni.com/patents).

© 2005 National Instruments Corp. All rights reserved.