

INSTALLATION GUIDE

SCXI™-1317 Terminal Block

This guide describes how to install and use the SCXI-1317 terminal block with the SCXI-1521/B quarter-bridge strain-gauge module.

Using the SCXI-1317 terminal block with the SCXI-1521/B module enables you to conveniently connect quarter-bridge strain gauges. For a complete description of the use and operation of the SCXI-1521/B module, refer to the *SCXI-1521/B User Manual*.

Conventions

The following conventions are used in this manual:

» The » symbol leads you through nested menu items and dialog box options to a final action. The sequence **File»Page Setup»Options** directs you to pull down the **File** menu, select the **Page Setup** item, and select **Options** from the last dialog box.



This icon denotes a note, which alerts you to important information.



This icon denotes a caution, which advises you of precautions to take to avoid injury, data loss, or a system crash. When this icon is marked on the product, refer to the *Read Me First: Safety and Radio-Frequency Interference* document, shipped with the product, for precautions to take.



When symbol is marked on a product it denotes a warning advising you to take precautions to avoid electrical shock.



When symbol is marked on a product it denotes a component that may be hot. Touching this component may result in bodily injury.

bold

Bold text denotes items that you must select or click in the software, such as menu items and dialog box options. Bold text also denotes parameter names.

| | |
|---------------|---|
| <i>italic</i> | Italic text denotes variables, emphasis, a cross reference, or an introduction to a key concept. This font also denotes text that is a placeholder for a word or value that you must supply. |
| monospace | Text in this font denotes text or characters that you should enter from the keyboard, sections of code, programming examples, and syntax examples. This font is also used for the proper names of disk drives, paths, directories, programs, subprograms, subroutines, device names, functions, operations, variables, filenames, and extensions. |
| SCXI-1521/B | SCXI-1521/B refers to either the SCXI-1521 or SCXI-1521B module. |

What You Need to Get Started

To install and use the SCXI-1317 terminal block, you need the following items:

- ❑ Hardware
 - SCXI-1317 terminal block
 - SCXI-1521/B module
 - SCXI or PXI/SCXI combination chassis
 - Cabling, cable adapter, and quarter-bridge strain gauges as required for your application
- ❑ Documentation
 - *Read Me First: Safety and Radio-Frequency Interference*
 - *SCXI Quick Start Guide*
 - *SCXI-1317 Terminal Block Installation Guide*
 - *SCXI-1521/B User Manual*
 - SCXI or PXI/SCXI combination chassis user manual
- ❑ Tools
 - Number 2 Phillips screwdriver
 - Long-nose pliers
 - Wire cutter

Quarter-Bridge 2- and 3-Wire Strain-Gauge Circuits



Note Refer to the *Read Me First: Safety and Radio-Frequency Interference* document before removing equipment covers or connecting or disconnecting any signal wires.

This section provides information about making quarter-bridge signal connections using either a 2- or 3-wire strain gauge. Figures 1 and 2 show the circuit wiring diagrams. If the transducer is shielded, connect the shield to the GND connection on the SCXI-1317 terminal block.

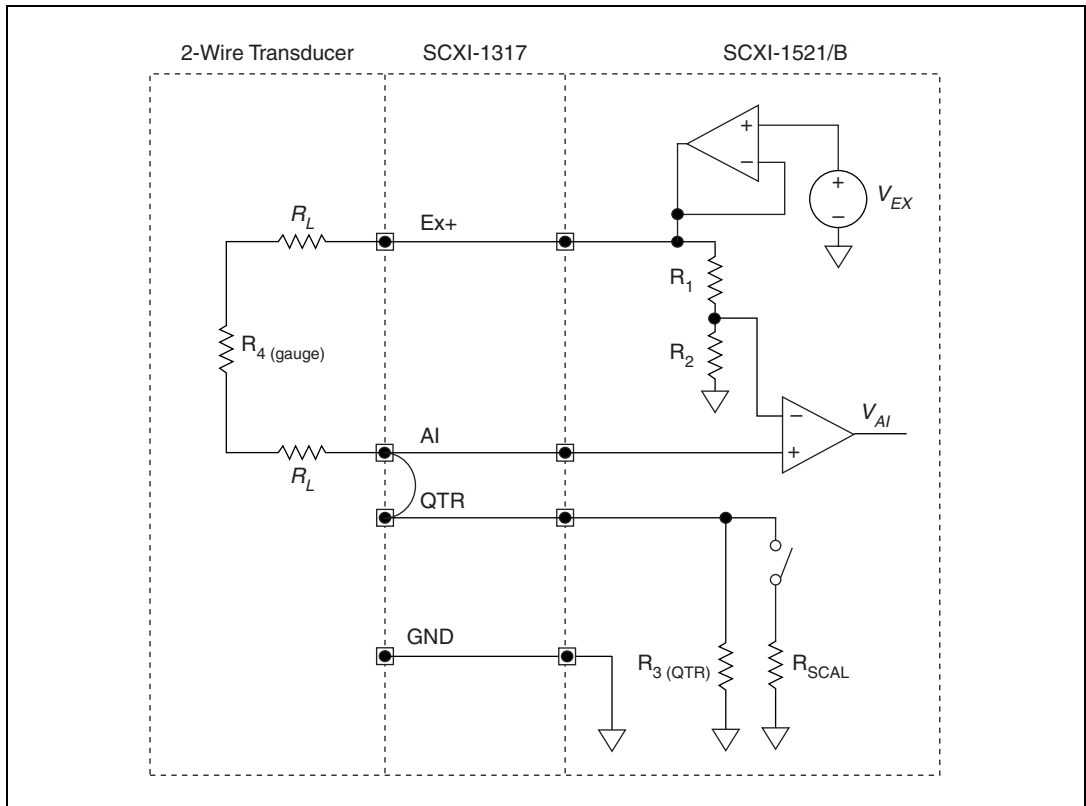

Figure 1. Quarter-Bridge Circuit Diagram Using a 2-Wire Strain Gauge

The following symbols apply to the circuit diagram and equations:

- R_1 and R_2 are half-bridge completion resistors.
- R_3 is the quarter-bridge completion resistor (dummy resistor).
- R_4 is the active measuring element.
- R_{SCAL} is the shunt-calibration resistor.

- V_{EX} is the excitation voltage.
- R_L is the lead resistance.
- V_{AI} is the measured voltage.

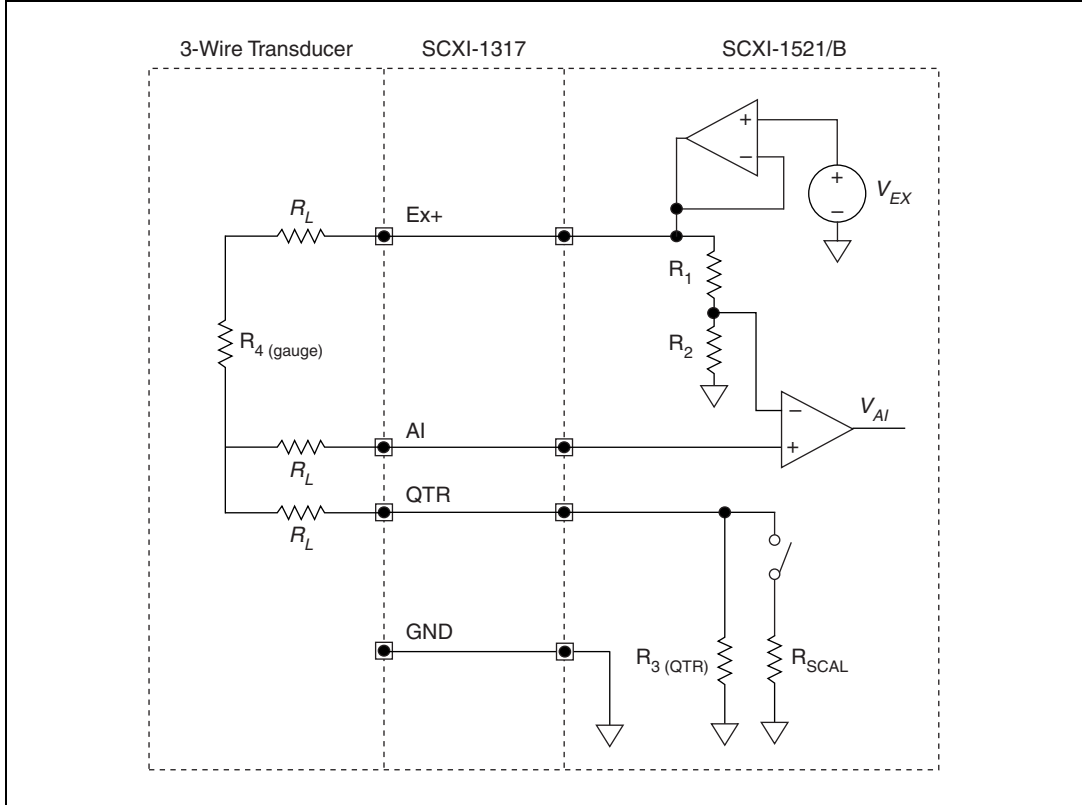

Figure 2. Quarter-Bridge Circuit Diagram Using a 3-Wire Strain Gauge

The following symbols apply to the circuit diagram and equations:

- R_1 and R_2 are half-bridge completion resistors.
- R_3 is the quarter-bridge completion resistor (dummy resistor).
- R_4 is the active measuring element.
- R_{SCAL} is the shunt-calibration resistor.
- V_{EX} is the excitation voltage.
- R_L is the lead resistance.
- V_{AI} is the measured voltage.

Connecting the Signals

To connect the signal to the terminal block, refer to Figures 3 and 4 while completing the following steps.

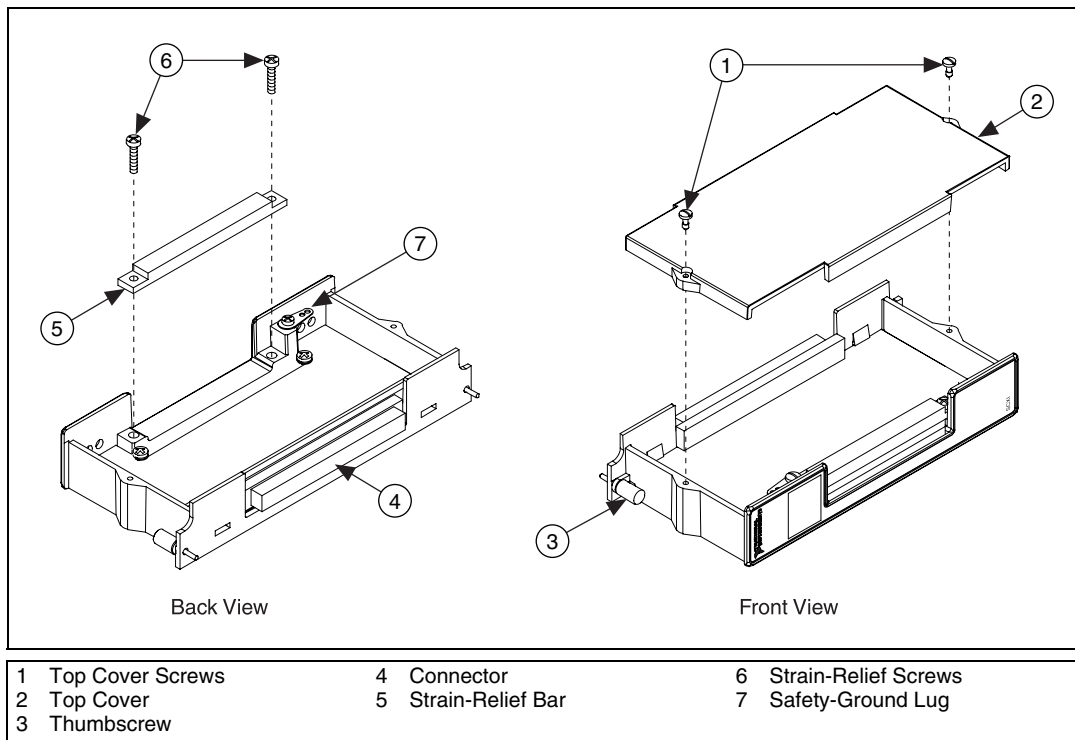

Figure 3. SCXI-1317 Enclosure Parts Locator Diagram

1. Unscrew the top cover screws and remove the top cover.
2. Loosen the strain-relief screws and remove the strain-relief bar.
3. Prepare your signal wire by stripping the insulation no more than 7 mm (0.28 in.).
4. Run the signal wires through the strain-relief opening. If necessary, add insulation or padding.
5. Insert the stripped end of the signal wires fully into the terminal. Make sure no bare wire extends past the screw terminal. Exposed wire increases the risk of a short circuit that can cause circuit failure.



Note When connecting your signals to the SCXI-1317, follow the labeling on the SCXI-1317, as shown in Figure 4. You can connect the shield of a shielded cable to GND.

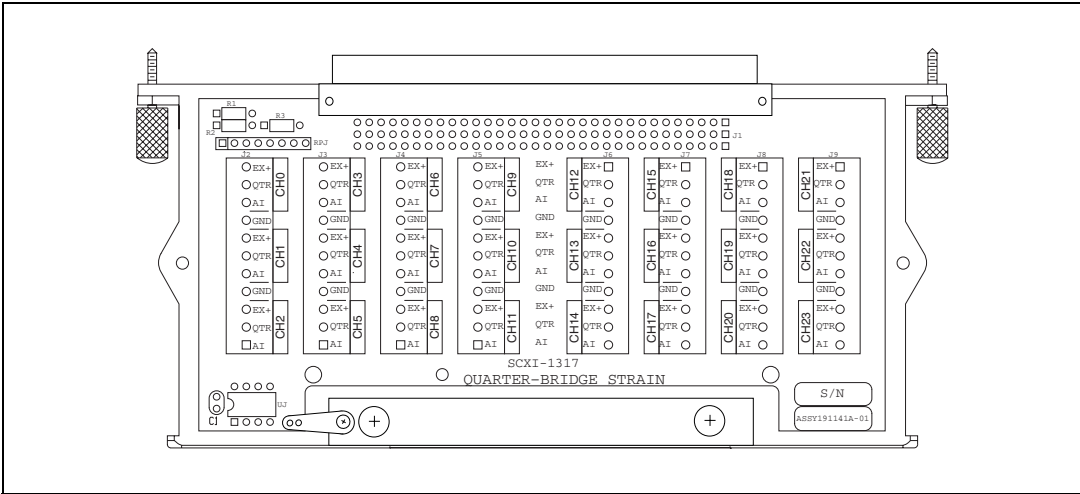

Figure 4. SCXI-1317 Circuit Parts Location Diagram

6. Tighten the terminal screws to a torque of 0.57 to 0.79 N · m (5 to 7 lb - in.).
7. Reinstall the strain-relief bar and tighten the strain-relief screws.
8. Reinstall the top cover and tighten the top cover screws.
9. Attach the SCXI-1317 to the SCXI-1521/B using the thumbscrews.
10. Refer to the *SCXI Quick Start Guide* to power on the SCXI chassis and configure the system in software.

Specifications

All specifications are typical at 25 °C unless otherwise specified.

Mechanical

Dimensions15.0 cm by 7.9 cm by 3.1 cm
(5.9 in. by 3.1 in. by 1.2 in.)

Maximum Working Voltage

Maximum working voltage refers to the signal voltage plus the common-mode voltage.

Channel-to-earth42 V_{rms}, Installation Category I

Channel-to-channel.....42 V_{rms}, Installation Category I



Note Refer to the *SCXI-1521/B User Manual* for valid input specifications.

Environmental

| | |
|--|-----------------------------|
| Operating temperature..... | 0 to 50 °C |
| Storage temperature | -20 to 70 °C |
| Humidity | 10 to 90% RH, noncondensing |
| Maximum altitude | 2,000 m |
| Pollution Degree (indoor use only) | 2 |

Safety

The SCXI-1317 terminal block meets the requirements of the following standards for safety and electrical equipment for measurement, control, and laboratory use:

- IEC 61010-1, EN 61010-1
- UL 61010-1
- CAN/CSA C22.2 No. 61010.1



Note For UL and other safety certifications, refer to the product label, or visit ni.com/certification, search by model number or product line, and click the appropriate link in the Certification column.

Electromagnetic Compatibility

| | |
|-----------------|--|
| Emissions | EN 55011 Class A at 10 m FCC Part 15A above 1 GHz |
| Immunity | EN 61326-1:1997 + A2:2001, Table 1 |
| EMC/EMI..... | CE, C-Tick, and FCC Part 15 (Class A) Compliant |



Note For EMC compliance, operate this device with shielded cabling.

CE Compliance

The SCXI-1317 terminal block meets the essential requirements of applicable European Directives, as amended for CE marking, as follows:

Low-Voltage Directive (safety).....73/23/EEC

Electromagnetic Compatibility
Directive (EMC).....89/336/EEC



Note Refer to the Declaration of Conformity (DoC) for this product for any additional regulatory compliance information. To obtain the DoC for this product, visit ni.com/certification, search by model number or product line, and click the appropriate link in the Certification column.

