

# TPC-2106/2106T

## User Manual

## **Worldwide Technical Support and Product Information**

ni.com

### **National Instruments Corporate Headquarters**

11500 North Mopac Expressway Austin, Texas 78759-3504 USA Tel: 512 683 0100

### **Worldwide Offices**

Australia 1800 300 800, Austria 43 662 457990-0, Belgium 32 (0) 2 757 0020, Brazil 55 11 3262 3599,  
Canada 800 433 3488, China 86 21 5050 9800, Czech Republic 420 224 235 774, Denmark 45 45 76 26 00,  
Finland 358 (0) 9 725 72511, France 01 57 66 24 24, Germany 49 89 7413130, India 91 80 41190000,  
Israel 972 3 6393737, Italy 39 02 413091, Japan 81 3 5472 2970, Korea 82 02 3451 3400,  
Lebanon 961 (0) 1 33 28 28, Malaysia 1800 887710, Mexico 01 800 010 0793, Netherlands 31 (0) 348 433 466,  
New Zealand 0800 553 322, Norway 47 (0) 66 90 76 60, Poland 48 22 3390150, Portugal 351 210 311 210,  
Russia 7 495 783 6851, Singapore 1800 226 5886, Slovenia 386 3 425 42 00, South Africa 27 0 11 805 8197,  
Spain 34 91 640 0085, Sweden 46 (0) 8 587 895 00, Switzerland 41 56 2005151, Taiwan 886 02 2377 2222,  
Thailand 662 278 6777, Turkey 90 212 279 3031, United Kingdom 44 (0) 1635 523545

For further support information, refer to the *Technical Support and Professional Services* appendix. To comment on National Instruments documentation, refer to the National Instruments Web site at [ni.com/info](http://ni.com/info) and enter the info code `feedback`.

# Important Information

---

## Warranty

The TPC-2106/2106T is warranted against defects in materials and workmanship for a period of one year from the date of shipment, as evidenced by receipts or other documentation. National Instruments will, at its option, repair or replace equipment that proves to be defective during the warranty period. This warranty includes parts and labor.

The media on which you receive National Instruments software are warranted not to fail to execute programming instructions, due to defects in materials and workmanship, for a period of 90 days from date of shipment, as evidenced by receipts or other documentation. National Instruments will, at its option, repair or replace software media that do not execute programming instructions if National Instruments receives notice of such defects during the warranty period. National Instruments does not warrant that the operation of the software shall be uninterrupted or error free.

A Return Material Authorization (RMA) number must be obtained from the factory and clearly marked on the outside of the package before any equipment will be accepted for warranty work. National Instruments will pay the shipping costs of returning to the owner parts which are covered by warranty.

National Instruments believes that the information in this document is accurate. The document has been carefully reviewed for technical accuracy. In the event that technical or typographical errors exist, National Instruments reserves the right to make changes to subsequent editions of this document without prior notice to holders of this edition. The reader should consult National Instruments if errors are suspected. In no event shall National Instruments be liable for any damages arising out of or related to this document or the information contained in it.

EXCEPT AS SPECIFIED HEREIN, NATIONAL INSTRUMENTS MAKES NO WARRANTIES, EXPRESS OR IMPLIED, AND SPECIFICALLY DISCLAIMS ANY WARRANTY OF MERCHANTABILITY OR FITNESS FOR A PARTICULAR PURPOSE. CUSTOMER'S RIGHT TO RECOVER DAMAGES CAUSED BY FAULT OR NEGLIGENCE ON THE PART OF NATIONAL INSTRUMENTS SHALL BE LIMITED TO THE AMOUNT THERETOFORE PAID BY THE CUSTOMER. NATIONAL INSTRUMENTS WILL NOT BE LIABLE FOR DAMAGES RESULTING FROM LOSS OF DATA, PROFITS, USE OF PRODUCTS, OR INCIDENTAL OR CONSEQUENTIAL DAMAGES, EVEN IF ADVISED OF THE POSSIBILITY THEREOF. This limitation of the liability of National Instruments will apply regardless of the form of action, whether in contract or tort, including negligence. Any action against National Instruments must be brought within one year after the cause of action accrues. National Instruments shall not be liable for any delay in performance due to causes beyond its reasonable control. The warranty provided herein does not cover damages, defects, malfunctions, or service failures caused by owner's failure to follow the National Instruments installation, operation, or maintenance instructions; owner's modification of the product; owner's abuse, misuse, or negligent acts; and power failure or surges, fire, flood, accident, actions of third parties, or other events outside reasonable control.

## Copyright

Under the copyright laws, this publication may not be reproduced or transmitted in any form, electronic or mechanical, including photocopying, recording, storing in an information retrieval system, or translating, in whole or in part, without the prior written consent of National Instruments Corporation.

National Instruments respects the intellectual property of others, and we ask our users to do the same. NI software is protected by copyright and other intellectual property laws. Where NI software may be used to reproduce software or other materials belonging to others, you may use NI software only to reproduce materials that you may reproduce in accordance with the terms of any applicable license or other legal restriction.

## Trademarks

National Instruments, NI, ni.com, and LabVIEW are trademarks of National Instruments Corporation. Refer to the *Terms of Use* section on [ni.com/legal](http://ni.com/legal) for more information about National Instruments trademarks.

Other product and company names mentioned herein are trademarks or trade names of their respective companies.

Members of the National Instruments Alliance Partner Program are business entities independent from National Instruments and have no agency, partnership, or joint-venture relationship with National Instruments.

## Patents

For patents covering National Instruments products, refer to the appropriate location: **Help»Patents** in your software, the `patents.txt` file on your CD, or [ni.com/patents](http://ni.com/patents).

## WARNING REGARDING USE OF NATIONAL INSTRUMENTS PRODUCTS

(1) NATIONAL INSTRUMENTS PRODUCTS ARE NOT DESIGNED WITH COMPONENTS AND TESTING FOR A LEVEL OF RELIABILITY SUITABLE FOR USE IN OR IN CONNECTION WITH SURGICAL IMPLANTS OR AS CRITICAL COMPONENTS IN ANY LIFE SUPPORT SYSTEMS WHOSE FAILURE TO PERFORM CAN REASONABLY BE EXPECTED TO CAUSE SIGNIFICANT INJURY TO A HUMAN.

(2) IN ANY APPLICATION, INCLUDING THE ABOVE, RELIABILITY OF OPERATION OF THE SOFTWARE PRODUCTS CAN BE IMPAIRED BY ADVERSE FACTORS, INCLUDING BUT NOT LIMITED TO FLUCTUATIONS IN ELECTRICAL POWER SUPPLY, COMPUTER HARDWARE MALFUNCTIONS, COMPUTER OPERATING SYSTEM SOFTWARE FITNESS, FITNESS OF COMPILERS AND DEVELOPMENT SOFTWARE USED TO DEVELOP AN APPLICATION, INSTALLATION ERRORS, SOFTWARE AND HARDWARE COMPATIBILITY PROBLEMS, MALFUNCTIONS OR FAILURES OF ELECTRONIC MONITORING OR CONTROL DEVICES, TRANSIENT FAILURES OF ELECTRONIC SYSTEMS (HARDWARE AND/OR SOFTWARE), UNANTICIPATED USES OR MISUSES, OR ERRORS ON THE PART OF THE USER OR APPLICATIONS DESIGNER (ADVERSE FACTORS SUCH AS THESE ARE HEREAFTER COLLECTIVELY TERMED "SYSTEM FAILURES"). ANY APPLICATION WHERE A SYSTEM FAILURE WOULD CREATE A RISK OF HARM TO PROPERTY OR PERSONS (INCLUDING THE RISK OF BODILY INJURY AND DEATH) SHOULD NOT BE RELIANT SOLELY UPON ONE FORM OF ELECTRONIC SYSTEM DUE TO THE RISK OF SYSTEM FAILURE. TO AVOID DAMAGE, INJURY, OR DEATH, THE USER OR APPLICATION DESIGNER MUST TAKE REASONABLY PRUDENT STEPS TO PROTECT AGAINST SYSTEM FAILURES, INCLUDING BUT NOT LIMITED TO BACK-UP OR SHUT DOWN MECHANISMS. BECAUSE EACH END-USER SYSTEM IS CUSTOMIZED AND DIFFERS FROM NATIONAL INSTRUMENTS' TESTING PLATFORMS AND BECAUSE A USER OR APPLICATION DESIGNER MAY USE NATIONAL INSTRUMENTS PRODUCTS IN COMBINATION WITH OTHER PRODUCTS IN A MANNER NOT EVALUATED OR CONTEMPLATED BY NATIONAL INSTRUMENTS, THE USER OR APPLICATION DESIGNER IS ULTIMATELY RESPONSIBLE FOR VERIFYING AND VALIDATING THE SUITABILITY OF NATIONAL INSTRUMENTS PRODUCTS WHENEVER NATIONAL INSTRUMENTS PRODUCTS ARE INCORPORATED IN A SYSTEM OR APPLICATION, INCLUDING, WITHOUT LIMITATION, THE APPROPRIATE DESIGN, PROCESS AND SAFETY LEVEL OF SUCH SYSTEM OR APPLICATION.

# Compliance

---

## Compliance with FCC/Canada Radio Frequency Interference Regulations

### Determining FCC Class

The Federal Communications Commission (FCC) has rules to protect wireless communications from interference. The FCC places digital electronics into two classes. These classes are known as Class A (for use in industrial-commercial locations only) or Class B (for use in residential or commercial locations). All National Instruments (NI) products are FCC Class A products.

Depending on where it is operated, this Class A product could be subject to restrictions in the FCC rules. (In Canada, the Department of Communications (DOC), of Industry Canada, regulates wireless interference in much the same way.) Digital electronics emit weak signals during normal operation that can affect radio, television, or other wireless products.

All Class A products display a simple warning statement of one paragraph in length regarding interference and undesired operation. The FCC rules have restrictions regarding the locations where FCC Class A products can be operated.

Consult the FCC Web site at [www.fcc.gov](http://www.fcc.gov) for more information.

### FCC/DOC Warnings

This equipment generates and uses radio frequency energy and, if not installed and used in strict accordance with the instructions in this manual and the CE marking Declaration of Conformity\*, may cause interference to radio and television reception. Classification requirements are the same for the Federal Communications Commission (FCC) and the Canadian Department of Communications (DOC).

Changes or modifications not expressly approved by NI could void the user's authority to operate the equipment under the FCC Rules.

### Class A

#### Federal Communications Commission

This equipment has been tested and found to comply with the limits for a Class A digital device, pursuant to part 15 of the FCC Rules. These limits are designed to provide reasonable protection against harmful interference when the equipment is operated in a commercial environment. This equipment generates, uses, and can radiate radio frequency energy and, if not installed and used in accordance with the instruction manual, may cause harmful interference to radio communications. Operation of this equipment in a residential area is likely to cause harmful interference in which case the user is required to correct the interference at their own expense.

#### Canadian Department of Communications

This Class A digital apparatus meets all requirements of the Canadian Interference-Causing Equipment Regulations.

Cet appareil numérique de la classe A respecte toutes les exigences du Règlement sur le matériel brouilleur du Canada.

### Compliance with EU Directives

Users in the European Union (EU) should refer to the Declaration of Conformity (DoC) for information\* pertaining to the CE marking. Refer to the Declaration of Conformity (DoC) for this product for any additional regulatory compliance information. To obtain the DoC for this product, visit [ni.com/certification](http://ni.com/certification), search by model number or product line, and click the appropriate link in the Certification column.

\* The CE marking Declaration of Conformity contains important supplementary information and instructions for the user or installer.

# Conventions

---

The following conventions are used in this manual:

» The » symbol leads you through nested menu items and dialog box options to a final action. The sequence **File»Page Setup»Options** directs you to pull down the **File** menu, select the **Page Setup** item, and select **Options** from the last dialog box.



This icon denotes a note, which alerts you to important information.



This icon denotes a caution, which advises you of precautions to take to avoid injury, data loss, or a system crash. When this symbol is marked on a product, refer to the *Safety* section of Appendix A, *Specifications*, for information about precautions to take.



When symbol is marked on a product, it denotes a warning advising you to take precautions to avoid electrical shock.



When symbol is marked on a product, it denotes a component that may be hot. Touching this component may result in bodily injury.

**bold** Bold text denotes items that you must select or click in the software, such as menu items and dialog box options. Bold text also denotes parameter names.

*italic* Italic text denotes variables, emphasis, a cross-reference, or an introduction to a key concept. Italic text also denotes text that is a placeholder for a word or value that you must supply.

`monospace` Text in this font denotes text or characters that you should enter from the keyboard, sections of code, programming examples, and syntax examples. This font is also used for the proper names of disk drives, paths, directories, programs, subprograms, subroutines, device names, functions, operations, variables, filenames, and extensions.

**`monospace bold`** Bold text in this font denotes the messages and responses that the computer automatically prints to the screen. This font also emphasizes lines of code that are different from the other examples.

# Contents

---

## Chapter 1

### General Information

Introduction .....	1-1
I/O Ports .....	1-1
Storage .....	1-2
Cleaning .....	1-2

## Chapter 2

### System Setup

Important Safety Information .....	2-1
Setup .....	2-2
Touchscreen Calibration.....	2-3
Panel Mounting.....	2-4

## Chapter 3

### System Configuration

Display Settings .....	3-1
Touchscreen Calibration .....	3-2
Beep Settings .....	3-2

## Chapter 4

### Windows CE .NET

TPC Utilities .....	4-1
Soft Keyboard.....	4-1
TPC Configuration .....	4-1
General .....	4-2
Network.....	4-2
Watchdog .....	4-2
Misc.....	4-2
Tools.....	4-3
ActiveSync .....	4-3
Registry Editor .....	4-3
Registry Saver .....	4-3
Remote Display Application.....	4-4
NotepadPlus .....	4-4
TPC Configurator.....	4-4
TPC Version Information.....	4-4

Other Utilities.....	4-4
Bright.exe [Level]:.....	4-4
Buzzer.exe [frequency] [duration]:.....	4-4
Contrast.exe [Level]: .....	4-5
RegSave.exe [-s]: .....	4-5
Reboot.exe: .....	4-5
Screen.exe [on/off]: .....	4-5
Iesample.exe [-n] [-f] [ip address/ folder name]:.....	4-5
Networking .....	4-5
Networking Via Ethernet .....	4-5
Networking Via the Serial Port .....	4-6
ActiveSync Setup .....	4-6
Networking via the USB Client Port.....	4-7

## **Appendix A Specifications**

## **Appendix B Watchdog Timer Programming**

## **Appendix C Fuse Replacement**

## **Appendix D Pin Assignments**

## **Appendix E Technical Support and Professional Services**

## **Index**

---

# General Information

This chapter includes general information about the TPC-2106/2106T Human Machine Interface (HMI).

## Introduction

---

The TPC-2106/2106T touch panel computer, a state-of-the-art RISC-based HMI, includes these key features:

- **Fanless**—Because the system uses a low-power processor, it does not need fans, which often are unreliable and cause dust to circulate inside the equipment.
- **Bright display**—The CSTN LCD features a 5.7 in. (5.6 in. for the TPC-2106T) display that meets industrial demands for clear interfaces.
- **Powerful Communication Capability**—The TPC-2106/2106T is a powerful I/O interface for easy communication with other devices. The I/O interface includes RS232 and RS485 serial, Ethernet, and USB ports.
- **Windows CE Support**—An optional Windows CE operating system specifically for the TPC-2106/2106T is available for Windows CE application program builders.
- **JVM Support**—The TPC-2106/2106T is powered by JVM, which is compatible with PersonalJava 1.2.

## I/O Ports

---

The TPC-2106/2106T includes the following ports:

- Three serial ports: two RS232 (COM1, COM2) and one configurable as RS485 (COM4) or RS232 (COM3)
- One RJ-45 Ethernet port
- Two USB ports compliant with USB 1.1: one USB Host (Type A) and one USB Client (Type B)
- One CompactFlash 2.0 type I/II slot

Figure 1-1 shows the I/O port arrangement.

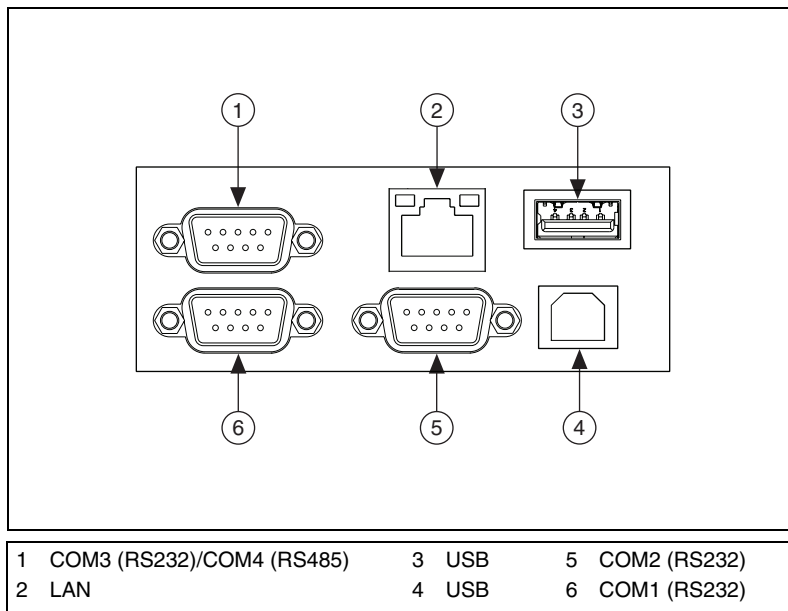

**Figure 1-1.** I/O Ports Arrangement

## Storage

The TPC-2106/2106T includes two storage methods: an onboard 64 MB NAND flash and a CompactFlash card. The system boot sequence is:

- If no CompactFlash card is installed, the system automatically boots from the onboard NAND flash.
- If a CompactFlash card is installed, the system boots from the CompactFlash card.

## Cleaning

If you need to clean the unit, use a soft, nonmetallic brush. Make sure that the unit is completely dry and free from contaminants before returning it to service.

---

# System Setup

This chapter includes setup information for the TPC-2106/2106T.

## Important Safety Information

---

Before setting up the TPC-2106/2106T, read these safety instructions carefully.

Disconnect this equipment from any AC outlet before cleaning. Use a damp cloth. Do not use liquid or spray detergents for cleaning.

For plug-in equipment, the power outlet socket must be located near the equipment and must be easily accessible.

Keep this equipment away from excessive humidity.

Place this equipment on a reliable surface during installation. Dropping it or letting it fall may cause damage.

The openings on the enclosure are for air convection. Protect the equipment from overheating. *Do not cover the openings.*

Make sure the power source voltage is correct before connecting the equipment to the power outlet.

Position the power cord so that it cannot be stepped on. Do not place anything over the power cord.

All cautions and warnings on the equipment should be noted.

If the equipment is not used for a long time, disconnect it from the power source to avoid damage by transient overvoltage.

Never pour any liquid into an opening. This may cause fire or electrical shock.

Never open the equipment. For safety reasons, only qualified service personnel should open the equipment.

If one of the following situations arises, have service personnel check the equipment:

- The power cord or plug is damaged.
- Liquid has penetrated into the equipment.
- The equipment has been exposed to moisture.
- The equipment does not work well, or you cannot get it to work according to the user manual.
- The equipment has been dropped and damaged.
- The equipment has obvious signs of breakage.

Do not leave this equipment in an environment where the storage temperature may go below  $-20\text{ }^{\circ}\text{C}$  ( $-4\text{ }^{\circ}\text{F}$ ) or above  $70\text{ }^{\circ}\text{C}$  ( $158\text{ }^{\circ}\text{F}$ ). Doing so could damage the equipment. The equipment should be in a controlled environment.



**Caution** There is a danger of explosion if the battery is incorrectly replaced. Replace the battery only with the same or equivalent type recommended by the manufacturer. Discard used batteries according to the manufacturer's instructions.



**Caution** The protection this equipment provides may be impaired if it is used in a manner not described in this manual.

## Setup

---

Follow these steps to set up the TPC-2106/2106T:

1. Unpack the TPC-2106/2106T. Be sure your kit includes the following items:
  - The TPC-2106/2106T HMI
  - Six panel mounting clamps
  - Six panel mounting screws
  - One 3-pin power connector and ground wire
  - One HMI resource CD
  - One 9-pin to 9-pin null modem cable
  - One Microsoft Windows CE end user license agreement
  - One 1.8 m USB client to USB host cable
  - One 6 cm single DB-9 to dual DB-9 serial ports shunting cable

If any items are missing or damaged, contact National Instruments.

2. Connect the power connector to 24 VDC power lines. Be sure to connect the positive, negative, and ground lines as shown in Figure 2-1. The power lines can be from either a power adapter or in-house power source.

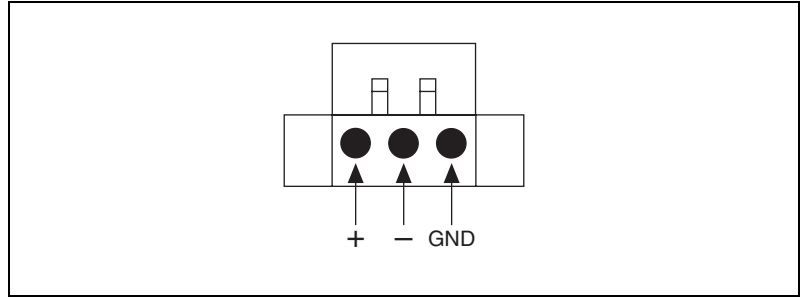

**Figure 2-1.** Power Connector

3. Connect the power connector to the power receptor on the TPC-2106/2106T. The power receptor pin assignment is shown in Figure 2-2.

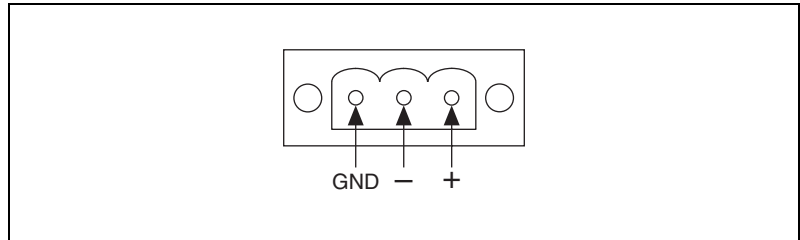

**Figure 2-2.** Power Receptor and Pin Assignment

4. Power on the system.

## Touchscreen Calibration

The TPC-2106/2106T touchscreen should be correctly calibrated and ready to use when you power on the system. However, if the calibration is not correct or you want to choose custom calibration options, refer to the [Touchscreen Calibration](#) section of Chapter 3, [System Configuration](#).

## Panel Mounting

---

Follow these steps to mount the TPC-2106/2106T in a panel:

1. Be sure the adhesive waterproof gasket on the front bezel is in position.
2. Install the TPC-2106/2106T into the panel opening. (Refer to Appendix A, *Specifications*, for cutout dimensions.)
3. Hook the clamps included in the accessory pack to the holes around the four sides of the bezel.
4. Insert the screws included in the accessory pack into the clamps. To fasten the TPC-2106/2106T to the panel, tighten the screws so they push against the mounting panel.



**Note** The mounting panel thickness should be less than 6 mm (0.236 in.).

---

# System Configuration

This chapter explains how to configure the TPC-2106/2106T.

## Display Settings

---

Use the display settings to control the backlight brightness and screen saver, which automatically turns off the screen when the TPC-2106/2106T is not in use for a designated time period. You can also select the system font size and rotate the screen.

Follow these steps to set the display properties:

1. Select **Start»Settings»Control Panel»Display** to access the **Display Properties** window.
2. To set the time to elapse before the backlight turns off, select the **Backlight** tab, click the **Automatically turn off backlight while on external power** checkbox, and select the time from the drop-down menu.
3. To set the LCD brightness, click the **Advanced** button to access the **Advanced Backlight Options** window. Move the slider or click + or – to adjust the LCD brightness and contrast. Click **OK**.

Follow these steps to select the system font size:

1. Select **Start»Programs»Utilities»System Font Setting** to access the **System Font Setting** window.
2. Select either **Normal System Font Size** or **Small System Font Size**.
3. Click **Yes** in the **Warning** window.
4. The system reboots and displays the font size you selected.

Follow these steps to rotate the screen:

1. Select **Start»Settings»Control Panel»Screen Rotation** to access the **Screen Rotation** window.
2. Select **Not Rotated**, **90 Degrees Counterclockwise**, **180 Degrees Counterclockwise**, or **270 Degrees Counterclockwise**.
3. Click **Apply**. The screen appears rotated as you selected.

## Touchscreen Calibration

---

Follow these steps to calibrate the touchscreen:

1. Select **Start»Settings»Control Panel»Stylus Properties** to access the **Stylus Properties** window.

There are two tabs in the **Stylus Properties** window: **Double-Tap** and **Calibration**. Use Double-Tap to record the time period between two taps when double-tapping in Windows CE. Use Calibration to calibrate the touchscreen.

2. Click the **Calibration** tab and click **Recalibrate** to calibrate the touchscreen. A cross appears on the screen in the following locations: center, upper left, lower left, lower right, and upper right. Use the stylus to tap the center of the cross until it moves to next location.

## Beep Settings

---

In Windows CE .NET, you can set the TPC-2106/2106T to beep when you touch the touchscreen.

Follow these steps to enable or disable this function:

1. Select **Start»Settings»Control Panel»Volume & Sounds** to access the Volume and Sounds Properties window.
2. Use the controls in the **Volume** tab to set the volume and enable or disable the beep for various events and inputs.

---

# Windows CE .NET

The TPC-2106/2106T is designed for Windows CE. Windows CE is a compact operating system that occupies less storage space and uses fewer system resources than other operating systems. Its modular nature allows you to choose functions useful for a specific application. This reduces required system resources and boot time. This feature is important in industrial automation and operator interface terminals, because downtime is minimized. Also, the small storage space required allows installation on a reliable solid-state disk.



**Note** The TPC-2106/2106T includes the English version of Windows CE by default. Contact National Instruments for local language support.



**Note** The TPC-2106/2106T supports Remote Desktop Connection in Windows CE, but the maximum resolution supported is only  $320 \times 240$ .

## TPC Utilities

---

Windows CE .NET on the TPC-2106/2106T includes several useful utilities.

### Soft Keyboard

The TPC-2106/2106T is designed for small operator interfaces. Because it is inconvenient to attach a keyboard to such a small device, Windows CE .NET on the TPC-2106/2106T includes a soft keyboard. On boot, a small keyboard icon appears in the status bar. Tap this icon with the stylus to activate or hide the soft keyboard.

### TPC Configuration

The TPC-2106/2106T includes an integrated utility to configure the basic device settings. To access the utility, click the **TPC Configurator** icon on the desktop. Navigate the configuration by tapping the four page tabs: **General**, **Network**, **Watchdog**, and **Misc**.

## General

The **General** page displays basic system information. There are two main parts: **System** and **Disk & Memory**. **System** shows the OS image version and CPU type. **Disk & Memory** includes total capacity, usage, and currently available capacity of the disk and memory.

## Network

The **Network** page displays information about the active network adapter. Click **Renew** to release the current IP and retrieve a new IP. Click **Ping** to ping a specified IP address to test the connection.

Click **Advanced** for more detailed IP information, including the default gateway, DHCP server, primary WINS server, and DNS server addresses.

## Watchdog

Using the watchdog function, the device automatically resets if a program does not respond in time. This prevents system crashes and hangs from stopping your critical applications, as the watchdog automatically restarts the machine when required.

Use the **Watchdog** tab to set the response time, which is the period that the watchdog waits for a response.

The response time is in effect only when you select a time span and enable the watchdog. When you enable the watchdog and click the **Test** button, the no resetting signal is sent to the watchdog hardware periodically. The watchdog assumes the machine is deadlocked and reboots it after the watchdog response time. If the machine reboots as expected after the watchdog response time, the watchdog is working properly.

## Misc

The **Misc** tab includes the following functions:



**Caution** Do not enter the CompactFlash folder name in the **CF Disk Name** text box directly. Renaming the CompactFlash folder to a name not on the list causes irreversible problems with application program settings.

- Use **Startup Programs** to set the startup programs without editing. The programs listed under **Startup Programs** are automatically executed after the system has successfully booted. Click **Add** to add a file to the startup. Click **Delete** to remove a file from the startup.



**Note** Do not try to insert a nonexecutable file into the startup program.

- Use **Reboot** to reboot the TPC-2106/2106T.  
There are two additional ways to reboot the system: clicking the machine icon in the status bar and executing the `reboot.exe` command through a command line program.
- Use the **Registry** options to save and view registry information. Click **Save** to save the registry to a solid state disk. Click **View** to view, edit, create, or delete registry information. You also can back up or restore the registry setting by clicking **Backup** or **Restore**.



**Note** You cannot back up and restore over different image versions.

- Use **Web Server Root** to enter the web server root path. The root path takes effect only after rebooting the machine.
- Use **Ftp Server Root** to enter the FTP server root path. The root path takes effect only after rebooting the machine.

## Tools

Select **Start»Programs»Utilities** to access the following tools.



**Note** For best results when accessing these tools, click the arrow to the right of the **Utilities** menu to avoid accidentally selecting a submenu item.

### ActiveSync

ActiveSync synchronizes data and monitors the connection between the TPC-2106/2106T and host computer. By default, ActiveSync executes automatically when you use it to establish a connection to a target device.

### Registry Editor

Use Registry Editor to view, edit, enter, delete, or save registry data.

### Registry Saver

Use Registry Saver to save the system registry. In a command line environment, you can execute Registry Saver using `regsave.exe` or `regsave.exe -s` for the silence mode.

## Remote Display Application

Remote Display Application displays a Windows CE device screen on a remote desktop. It works with the Windows CE Remote Display Host application.

Because the connection is over the network, the host machine and TPC-2106/2106T network functions must work properly. You must execute Remote Display Host (`cerhost.exe`) on a remote host desktop. Also, you must run Remote Display Application on the TPC-2106/2106T. In the CE Remote Display window, click **Connect** and enter the hostname or IP address.

After successfully establishing the connection, you can see the TPC-2106/2106T display and control it from the host machine.

## NotepadPlus

NotepadPlus is a text editor.

## TPC Configurator

TPC Configurator is an integrated utility for configuring the basic TPC-2106/2106T settings. For more information, refer to [TPC Configuration](#).

## TPC Version Information

TPC Version Information shows the OS version information.

## Other Utilities

The following utilities are command line-executed programs without graphical user interfaces. To execute these utilities, type the command names and parameters as shown below.

### **Bright.exe [Level]:**

Sets the display brightness level. The parameters are 1 to 10.

### **Buzzer.exe [frequency] [duration]:**

Plays a beep. Use parameters to set the frequency in Hertz and duration in milliseconds. If you do not use parameters, the default frequency is 350 Hz and default duration is 30 ms.

**Contrast.exe [Level]:**

Sets the display contrast. The parameters are 1 to 10.

**RegSave.exe [-s]:**

Saves the registry settings. If you use `RegSave.exe -s`, no message box is displayed whether you are successful or fail.

**Reboot.exe:**

Saves the registry settings and reboots the TPC-2106/2106T.

**Screen.exe [on/off]:**

Turns the display on/off. Use `Screen.exe on` to turn on and `Screen.exe off` to turn off the display.

**Iesample.exe [-n] [-f] [ip address/ folder name]:**

Launches Internet Explorer. Use `Iesample.exe -n` to close the scroll bar. Use `Iesamples.exe -f` to activate the full screen. The parameters can be blank.

## Networking

---

### Networking Via Ethernet

Follow these steps to configure the TPC-2106/2106T Ethernet port:



**Note** Be sure you are connected to a LAN before booting the system.



**Note** The data transfer buffer size per package via Ethernet is about 20,000.

1. Select **Start»Settings»Network and Dial-up Connections**.
2. A window displaying all available connections appears. Double-click the icon for the connection you want to configure.
3. Select the **IP Address** tab and select **Obtain an IP address via DHCP**.
4. Select the **Name Servers** tab and enter the server addresses.
5. Select **Start»Run**. Enter `regsave` to save the registry settings to a storage card.

## Networking Via the Serial Port

This section explains how to set up the connection between the TPC-2106/2106T and a host PC via ActiveSync.

### ActiveSync Setup

Follow these steps to set up ActiveSync:

1. Insert the TPC series support CD into the host PC CD-ROM.
2. Install the TPC software development kit for eVC++.
3. Install ActiveSync.
4. Connect the host computer and TPC with a null modem cable (included in the kit). Make sure the connection is solid on both RS232 serial ports.
5. Set up the TPC-2106/2106T and host communication environments as described below.

### Setting Up the TPC-2106/2106T Communication Environment



**Note** Before completing this section, change to the small system font size. Go to **Start»Programs»Utilities»System Font Setting**. Click **Small System Font Size**. Click **OK**. A confirmation appears, saying **This will change the system font size and reboot! Are you sure?**. Click **Yes**.

Follow these steps to set up the TPC-2106/2106T communication environment:

1. To configure COM1 on the TPC-2106/2106T, select **Start»Settings»Control Panel**.
2. Double-click the **PC Connection** icon.
3. Click **Change** to select the COM port.
4. In the Change Connection window, select **Serial1**.
5. Click **Enter** (the return arrow symbol) on the soft keyboard to confirm the change.
6. The PC Connection Properties window should display **Serial1** in the **Connect using:** field.

## Setting Up the Host Communication Environment

Follow these steps to set up the host communication environment:

1. Double-click the ActiveSync icon on the host computer.
2. In the Microsoft ActiveSync window, select **File»Connection Settings**.
3. In the Connection Settings window, select **Show status icon in taskbar**, **Allow USB connections**, **Allow connections to one of the following:** (select **COM1**), and **Open ActiveSync when my device connects**. Also, select **Automatic** in the **This computer is connected to:** list.
4. Click **Get Connected**. The Get Connected window appears. *Do not* click **Next** at this time.
5. On the TPC-2106/2106T, select **Start»Run**. Enter `\windows\repllog.exe` and click **OK**.
6. In the Get Connected window on the host computer, click **Next**.  
When the TPC and the host PC are connected, the Connected to My Connection window appears.
7. The New Partnership window appears on the host computer. Select **No** and click **Next**.
8. Click **Explore** in the Microsoft ActiveSync window. The Mobile Device window appears, displaying the TPC-2106/2106T file resources and information. For example, you could click **My Documents** to see documents on the TPC-2106/2106T.

## Networking via the USB Client Port

In addition to connecting via a null modem cable as described in the previous section, you can also connect via the client USB port. To do this, you must install ActiveSync on the host computer. Then use a USB cable to connect the client and host USB ports. Be sure the TPC-2106/2106T PC connection setting is USB Socket Default (the default setting). Then follow the steps above to connect the TPC-2106/2106T and host automatically.

---

## Specifications

This appendix lists the TPC-2106/2106T system specifications.

### Physical

Weight..... 0.8 kg

Cutout dimensions..... 188 × 141 mm (suggested)

## Dimensions

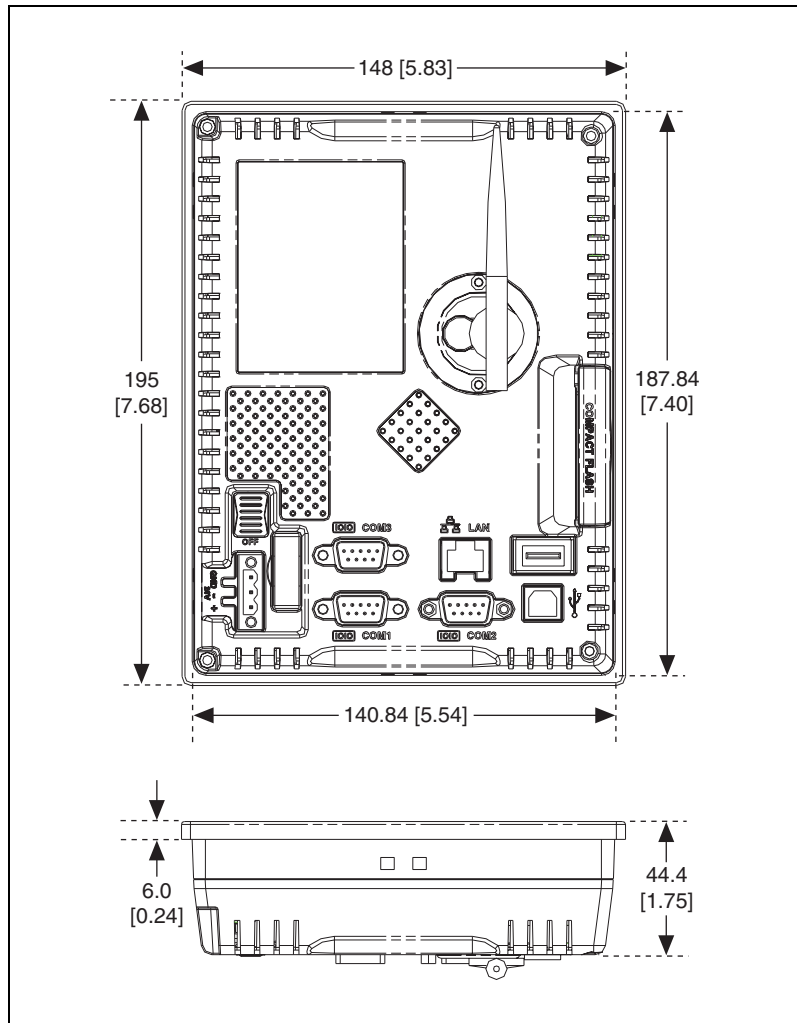

## System Kernel

CPU .....Intel XScale PXA 270, 416 MHz

VGA.....CPU built-in

DRAM .....Built-in 64 MB SDRAM

Storage memory.....64 MB onboard NAND flash

Ethernet ..... SMSC9115 10/100Base-T Ethernet controller; IEEE 802.3u protocol compatible

Watchdog timer ..... Intel XScale PXA watchdog timer; 2, 5, 10, 15, 30, 40 s timeout period option

CompactFlash ..... CompactFlash type I/II

## LCD

	<b>TPC-2106</b>	<b>TPC-2016T</b>
Display type	Color STN LCD	Color TFT LCD
Size (diagonal)	5.7 in.	5.6 in.
Maximum resolution	320 × 240 (QVGA)	320 × 240 (QVGA)
Maximum colors	4096	256k
Pixel pitch (W × H, mm)	0.12 × 0.36	—
Viewing angle	100°	100°
Luminance (cd/m <sup>2</sup> )	400	500
Contrast ratio	55	400
Operating temperature	0 to 50 °C (ambient)	0 to 50 °C (ambient)
Control	Contrast adjustable	N/A
Backlight	1 CCFL	1 CCFL
Backlight MTBF	75,000 h	30,000 h

## Touchscreen

Touch type ..... Resistive

Base glass construction ..... Tempered glass

Resolution ..... Continuous

Light transmission ..... 75% typical

Controller .....	DMC9000
Power rating .....	5 VDC
Software driver .....	Windows CE (embedded)
Durability .....	10 million times with an 8 mm diameter silicone rubber finger



**Note** No pointer/cursor appears when using the touchscreen. The cursor appears only when closing or minimizing the window.

## Power

Input voltage .....	18 to 32 VDC (the fuse becomes an open circuit if input level exceeds 33 VDC)
Maximum current .....	3.15 A (typical 24 VDC at 0.8 A)

## Fuse

Rating .....	T3.15A 250 V
Size .....	5 × 20 mm



**Note** When replacing the fuse, use only a fuse of the same type and rating.



**Note** The fuse is set to break if the input voltage exceeds 33 VDC.

## Environment

Operating temperature .....	0 to 50 °C
Storage temperature .....	-20 to 70 °C
Humidity .....	10 to 95% @ 40 °C relative humidity (noncondensing)
Vibration .....	10 to 18 Hz @ 1.5 mm peak-to-peak displacement; 18 to 500 Hz @ 1 G acceleration

Maximum altitude ..... 2,000 m

Pollution Degree ..... 2

Indoor use only

## Safety

This product is designed to meet the requirements of the following standards of safety for information technology equipment:

- IEC 60950-1, EN 60950-1
- UL 60950-1, CSA 60950-1



**Note** For UL and other safety certifications, refer to the product label or visit [ni.com/certification](http://ni.com/certification), search by model number or product line, and click the appropriate link in the Certification column.

## Electromagnetic Compatibility

This product is designed to meet the requirements of the following standards of EMC for electrical equipment for measurement, control, and laboratory use:

- EN 55024, CISPR 24 EMC requirements
- EN 55022, CISPR 22 Emissions; Class A
- EN 55011, CISPR 11 Emissions; Class A
- CE, C-Tick, ICES, and FCC Part 15 Emissions; Class A



**Note** For EMC compliance, operate this device according to product documentation.

## CE Compliance

This product meets the essential requirements of applicable European Directives, as amended for CE marking, as follows:

- 2006/95/EC; Low-Voltage Directive (safety)
- 2004/108/EEC; Electromagnetic Compatibility Directive (EMC)



**Note** Refer to the Declaration of Conformity (DoC) for this product for any additional regulatory compliance information. To obtain the DoC for this product, visit [ni.com/certification](http://ni.com/certification), search by model number or product line, and click the appropriate link in the Certification column.

## Environmental Management

National Instruments is committed to designing and manufacturing products in an environmentally responsible manner. NI recognizes that eliminating certain hazardous substances from our products is beneficial not only to the environment but also to NI customers.

For additional environmental information, refer to the *NI and the Environment* Web page at [ni.com/environment](http://ni.com/environment). This page contains the environmental regulations and directives with which NI complies, as well as any other environmental information not included in this document.

## Waste Electrical and Electronic Equipment (WEEE)



**EU Customers** At the end of their life cycle, all products *must* be sent to a WEEE recycling center. For more information about WEEE recycling centers and National Instruments WEEE initiatives, visit [ni.com/environment/weee.htm](http://ni.com/environment/weee.htm).

## 电子信息产品污染控制管理办法（中国 RoHS）



**中国客户** National Instruments 符合中国电子信息产品中限制使用某些有害物质指令 (RoHS)。关于 National Instruments 中国 RoHS 合规性信息, 请登录 [ni.com/environment/rohs\\_china](http://ni.com/environment/rohs_china)。(For information about China RoHS compliance, go to [ni.com/environment/rohs\\_china](http://ni.com/environment/rohs_china).)

## Mercury Disposal and Recycling

LCD lamp(s) in this monitor contain mercury. Dispose or recycle according to local, state or federal laws. Consult the Electronic Industries Alliance at [www.eiae.org](http://www.eiae.org) for more information. For specific information on lamp disposal, consult [www.lamprecycle.org](http://www.lamprecycle.org).

## Cleaning

If you need to clean the unit, use a soft, nonmetallic brush. Make sure that the unit is completely dry and free from contaminants before returning it to service.

---

# Watchdog Timer Programming

Windows CE includes a watchdog timer for the TPC-2106/2106T. You can access the timer through the WIN32 API. The TPC-2106/2106T includes a WDT driver, WDT1:, for enabling/disabling the watchdog timer. You must open this driver before using the resources, and then use the DeviceIOControl function to enable/disable the watchdog timer.

This appendix describes DeviceIOControl and its parameters. It also includes a programming example.

---

## DeviceIOControl

DeviceIOControl sends a control code directly to a specified device driver, causing the corresponding device to perform the specified operation. The function and its parameters are:

```
BOOL DeviceIoControl( HANDLE hDevice, DWORD
dwIoControlCode, LPVOID lpInBuffer, DWORD nInBufferSize,
LPVOID lpOutBuffer, DWORD nOutBufferSize, LPDWORD
lpBytesReturned, LPOVERLAPPED lpOverlapped );
```

## Parameters

DeviceIOControl includes the following parameters:

- `hDevice`  
(in) Handle to the device that performs the operation. Call the `CreateFile` function to obtain a device handle.
- `dwIoControlCode`  
(in) Specifies the operation control code. This value identifies the specific operation to be performed and the type of device on which the operation is to be performed. No specific values are defined for the `dwIoControlCode` parameter. However, if you write a custom device driver, you can define `IOCTL_XXXX` control codes, per the `CTL_CODE` macro. You then can advertise these control codes, and an application can use these control codes with `DeviceIoControl` to perform driver-specific functions.

- `lpInBuffer`  
(in) Long pointer to a buffer that contains the data required to perform the operation. This parameter can be NULL if the `dwIoControlCode` parameter specifies an operation that does not require input data.
- `nInBufferSize`  
(in) Size, in bytes, of the buffer pointed to by `lpInBuffer`.
- `lpOutBuffer`  
(out) Long pointer to a buffer that receives the operation's output data. This parameter can be NULL if the `dwIoControlCode` parameter specifies an operation that does not produce output data.
- `nOutBufferSize`  
(in) Size, in bytes, of the buffer pointed to by `lpOutBuffer`.
- `lpBytesReturned`  
(out) Long pointer to a variable that receives the size, in bytes, of the data stored into the buffer pointed to by `lpOutBuffer`. The `lpBytesReturned` parameter cannot be NULL. Even when an operation produces no output data, and `lpOutBuffer` can be NULL, `DeviceIoControl` makes use of the variable pointed to by `lpBytesReturned`. After such an operation, the variable value has no meaning.
- `lpOverlapped`  
(in) Ignored; set to NULL.
- Return Values  
Nonzero indicates success. Zero indicates failure. To get extended error information, call `GetLastError`.

## How to Use the Control Codes

---

There are six control codes for the WDT driver operation codes.

### IOCTL\_WDT\_ENABLE

Enables the application watchdog timer. By default, if the watchdog timer is enabled, the WDT driver automatically triggers itself after the specified period, and your application does not need to trigger the watchdog timer.

- `lpInBuffer`: unused
- `nInBufferSize`: unused

- lpOutBuffer: unused
- nOutBufferSize: unused

## IOCTL\_WDT\_DISABLE

Disables the application watchdog timer.

- lpInBuffer: unused
- nInBufferSize: unused
- lpOutBuffer: unused
- nOutBufferSize: unused

## IOCTL\_WDT\_STROBE

Triggers the watchdog. If your application uses IOCTL\_WDT\_ENABLE to enable the watchdog first and then sends IOCTL\_WDT\_REBOOT to the WDT driver, your application must trigger the watchdog once during the watchdog timer period. If your application has not triggered at the specified period, the device reboots automatically.

- lpInBuffer: unused
- nInBufferSize: unused
- lpOutBuffer: unused
- nOutBufferSize: unused

## IOCTL\_WDT\_GETTIMEOUT

Gets the watchdog time setting.

- lpInBuffer: unused
- nInBufferSize: unused
- lpOutBuffer: The DWORD pointer to your watchdog time setting. The watchdog time settings are:

Setting	Time
0	2 s
1 (default)	5 s (default)
2	10 s
3	15 s

Setting	Time
4	30 s
Other	40 s

- `nOutBufferSize`: unused

## IOCTL\_WDT\_SETTIMEOUT

Sets the watchdog time setting.

- `lpInBuffer`: The DWORD pointer to your watchdog time setting. The watchdog time settings are:

Setting	Time
0	2 s
1 (default)	5 s (default)
2	10 s
3	15 s
4	30 s
Other	40 s

- `nInBufferSize`: unused
- `lpOutBuffer`: unused
- `nOutBufferSize`: unused

## IOCTL\_WDT\_REBOOT

If you want your application to trigger the watchdog, use `IOCTL_WDT_REBOOT` to notify the watchdog driver timer (WDT). Otherwise, the WDT triggers itself automatically.

- `lpInBuffer`: unused
- `nInBufferSize`: unused
- `lpOutBuffer`: unused
- `nOutBufferSize`: unused

# Programming Example

---

```

#define WDT_CODE(ID) CTL_CODE(FILE_DEVICE_UNKNOWN, ID, METHOD_BUFFERED,
FILE_ANY_ACCESS)
#define IOCTL_WDT_ENABLE WDT_CODE (0x900)
#define IOCTL_WDT_DISABLE WDT_CODE(0x901)
#define IOCTL_WDT_STROBE WDT_CODE(0x902)
#define IOCTL_WDT_GET_TIMEOUT WDT_CODE(0x903)
#define IOCTL_WDT_SET_TIMEOUT WDT_CODE(0x904)
#define IOCTL_WDT_REBOOT WDT_CODE(0x905)
// for compatibility reasons, you can define IOCTL as below:
// #define IOCTL_WDT_ENABLE 0x1001
// #define IOCTL_WDT_DISABLE 0x1002
// #define IOCTL_WDT_STROBE 0x1003
// #define IOCTL_WDT_GETTIMEOUT 0x1004
// #define IOCTL_WDT_SETTIMEOUT 0x1005
// #define IOCTL_WDT_REBOOT 0x1006
HANDLE m_hWDT=NULL;
TCHAR szClassName[60];
// assign the WDT driver name
wsprintf(szClassName, TEXT("WDT1:"));
// Open the WDT driver
m_hWDT = CreateFile(szClassName, GENERIC_READ | GENERIC_WRITE, 0, NULL,
OPEN_EXISTING, FILE_ATTRIBUTE_NORMAL, NULL);
if ( m_hWDT == INVALID_HANDLE_VALUE ) { DebugMsg(CString("WDT driver fail"));
return;
}
DWORD dwTemp; DWORD nIndex=2;
// Set the Watchdog Timer as 10 seconds. Number 2 means 10 seconds.
DeviceIoControl(m_hWDT, IOCTL_WDT_SET_TIMEOUT, &nIndex, sizeof(nIndex),
NULL, 0, &dwTemp, NULL);
// Enable the Watchdog timer
DeviceIoControl(m_hWDT, IOCTL_WDT_ENABLE, NULL, 0, NULL, 0, &dwTemp, NULL);
While (1) {
// do your job here.
Sleep(8000);
DeviceIoControl(m_hWDT, IOCTL_WDT_STROBE, NULL, 0, NULL, 0, &dwTemp, NULL);
}
DeviceIoControl(m_hWDT, IOCTL_WDT_DISABLE, NULL, , NULL, 0, &dwTemp, NULL);
CloseHandle(m_hWDT);

```



---

# Fuse Replacement



**Caution** *Do not* replace the fuse unless it is damaged. *Do not* replace the fuse with a differently rated fuse. For more information, see the fuse specifications in Appendix A, *Specifications*.

Follow these steps to replace the fuse:

1. Remove the power cable.
2. Remove the fuse cover.
3. Replace the damaged fuse with a new one.
4. Place the fuse cover back into position.
5. Replace the power cable.

## Pin Assignments

### RS232 Pin Assignment

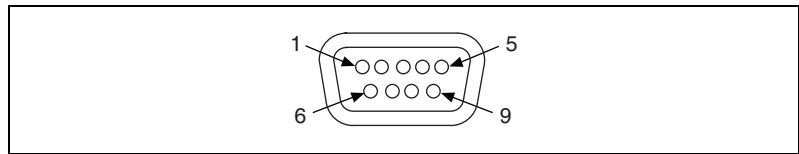

Pin Number	Description
Pin 1	DCD
Pin 2	Rx
Pin 3	Tx
Pin 4	DTR
Pin 5	GND
Pin 6	DSR
Pin 7	RTS
Pin 8	CTS
Pin 9	RI

## RS485 Pin Assignment

---

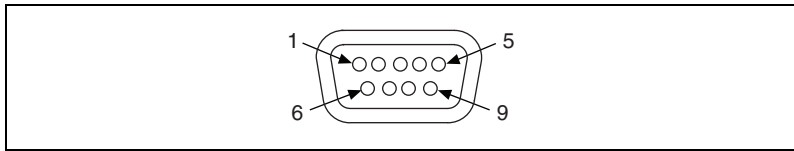

Pin Number	Description
Pin 1	DATA-
Pin 2	No Connection
Pin 3	No Connection
Pin 4	DATA+
Pin 5	GND
Pin 6	No Connection
Pin 7	No Connection
Pin 8	No Connection
Pin 9	No Connection

## COM Port Setting

---

The TPC-2106/2106T includes three COM ports: RS232 (COM1 and COM2), and 4-wire RS232 (COM3) or RS485 (COM4). COM3 and COM4 share the same DB9 connector, which you can set through the software.

---

# Technical Support and Professional Services

Visit the following sections of the National Instruments Web site at [ni.com](http://ni.com) for technical support and professional services:

- **Support**—Online technical support resources at [ni.com/support](http://ni.com/support) include the following:
  - **Self-Help Resources**—For answers and solutions, visit the award-winning National Instruments Web site for software drivers and updates, a searchable KnowledgeBase, product manuals, step-by-step troubleshooting wizards, thousands of example programs, tutorials, application notes, instrument drivers, and so on.
  - **Free Technical Support**—All registered users receive free Basic Service, which includes access to hundreds of Application Engineers worldwide in the NI Discussion Forums at [ni.com/forums](http://ni.com/forums). National Instruments Application Engineers make sure every question receives an answer.  
  
For information about other technical support options in your area, visit [ni.com/services](http://ni.com/services) or contact your local office at [ni.com/contact](http://ni.com/contact).
- **Training and Certification**—Visit [ni.com/training](http://ni.com/training) for self-paced training, eLearning virtual classrooms, interactive CDs, and Certification program information. You also can register for instructor-led, hands-on courses at locations around the world.
- **System Integration**—If you have time constraints, limited in-house technical resources, or other project challenges, National Instruments Alliance Partner members can help. To learn more, call your local NI office or visit [ni.com/alliance](http://ni.com/alliance).

If you searched [ni.com](http://ni.com) and could not find the answers you need, contact your local office or NI corporate headquarters. Phone numbers for our worldwide offices are listed at the front of this manual. You also can visit the Worldwide Offices section of [ni.com/niglobal](http://ni.com/niglobal) to access the branch office Web sites, which provide up-to-date contact information, support phone numbers, email addresses, and current events.

# Index

---

## A

ActiveSync, 4-3  
setup, 4-6

## B

beep settings, 3-2  
Bright.exe, 4-4  
Buzzer.exe, 4-4

## C

CE compliance specifications, A-5  
cleaning, 1-2, A-6  
COM port setting, D-2  
communication environment setup  
host, 4-7  
TPC-2106/2106T, 4-6  
configuration, 3-1  
Contrast.exe, 4-5  
control codes, using, B-2  
conventions used in the manual, *v*

## D

DeviceIOControl, B-1  
control codes  
IOCTL\_WDT\_DISABLE, B-3  
IOCTL\_WDT\_ENABLE, B-2  
IOCTL\_WDT\_GETTIMEOUT, B-3  
IOCTL\_WDT\_REBOOT, B-4  
IOCTL\_WDT\_SETTIMEOUT, B-4  
IOCTL\_WDT\_STROBE, B-3  
using, B-2  
parameters, B-1  
diagnostic tools (NI resources), E-1  
dimensions, A-2

display settings, 3-1  
documentation  
conventions used in the manual, *v*  
NI resources, E-1  
drivers (NI resources), E-1

## E

electromagnetic compatibility  
specifications, A-5  
environmental management  
specifications, A-6  
environmental specifications, A-4  
examples (NI resources), E-1

## F

font size, 3-1  
fuse  
replacement, C-1  
specifications, A-4

## G

General tab, 4-2

## H

help, technical support, E-1

## I

I/O ports, 1-1  
Iesample.exe, 4-5  
instrument drivers (NI resources), E-1  
introduction, 1-1  
IOCTL\_WDT\_DISABLE, B-3  
IOCTL\_WDT\_ENABLE, B-2

IOCTL\_WDT\_GETTIMEOUT, B-3  
IOCTL\_WDT\_REBOOT, B-4  
IOCTL\_WDT\_SETTIMEOUT, B-4  
IOCTL\_WDT\_STROBE, B-3

## K

KnowledgeBase, E-1

## L

LCD specifications, A-3

## M

mercury disposal and recycling  
specifications, A-6  
Misc tab, 4-2

## N

National Instruments support and  
services, E-1  
Network tab, 4-2  
networking, 4-5  
    via Ethernet, 4-5  
    via serial port, 4-6  
        ActiveSync setup, 4-6  
        host communication environment  
        setup, 4-7  
        TPC-2106/2106T communication  
        environment setup, 4-6  
    via USB client port, 4-7  
NI support and services, E-1  
NotepadPlus, 4-4

## P

panel mounting, 2-4  
physical specifications, A-1

pin assignments, D-1  
    RS232, D-1  
    RS485, D-2  
power connector (figure), 2-3  
power receptor (figure), 2-3  
power specifications, A-4  
programming examples (NI resources), E-1

## R

Reboot.exe, 4-5  
Registry Editor, 4-3  
Registry Saver, 4-3  
RegSave.exe, 4-5  
Remote Display Application, 4-4

## S

safety  
    information, 2-1  
    specifications, A-5  
screen rotation, 3-1  
Screen.exe, 4-5  
setup, 2-2  
soft keyboard, 4-1  
software (NI resources), E-1  
specifications, A-1  
    CE compliance, A-5  
    cleaning, 1-2, A-6  
    dimensions, A-2  
    electromagnetic compatibility, A-5  
    environmental, A-4  
    environmental management, A-6  
    fuse, A-4  
    LCD, A-3  
    mercury disposal and recycling, A-6  
    physical, A-1  
    power, A-4  
    safety, A-5  
    system kernel, A-2  
    touchscreen, A-3

- Waste Electrical and Electronic Equipment compliance, A-6
- storage, 1-2
- support, technical, E-1
- system configuration, 3-1
- system font size, 3-1
- system kernel specifications, A-2
- system setup, 2-2

## T

- technical support, E-1
- touchscreen
  - calibration, 2-3, 3-2
  - specifications, A-3
- TPC Configurator, 4-1, 4-4
  - General tab, 4-2
  - Misc tab, 4-2
  - Network tab, 4-2
  - watchdog, 4-2
- TPC utilities, 4-1
  - Bright.exe, 4-4
  - Buzzer.exe, 4-4
  - Contrast.exe, 4-5
  - Iesample.exe, 4-5
  - Reboot.exe, 4-5
  - RegSave.exe, 4-5
  - Screen.exe, 4-5
  - soft keyboard, 4-1
  - tools, 4-3
    - ActiveSync, 4-3
    - NotepadPlus, 4-4
    - Registry Editor, 4-3
    - Registry Saver, 4-3
    - Remote Display Application, 4-4
    - TPC Configurator, 4-4
    - TPC Version Information, 4-4
  - TPC Configurator, 4-1
  - TPC Version Information, 4-4
- TPC-2106/2106T
  - beep settings, 3-2
  - CE compliance specifications, A-5
  - cleaning specifications, 1-2, A-6
  - COM port setting, D-2
  - dimensions, A-2
  - display settings, 3-1
  - electromagnetic compatibility specifications, A-5
  - environmental management specifications, A-6
  - environmental specifications, A-4
  - fuse
    - replacement, C-1
    - specifications, A-4
  - I/O ports, 1-1
  - introduction, 1-1
  - LCD specifications, A-3
  - mercury disposal and recycling specifications, A-6
  - networking
    - via Ethernet, 4-5
    - via serial port, 4-6
      - ActiveSync setup, 4-6
      - host communication environment setup, 4-7
      - TPC-2106/2106T communication environment setup, 4-6
      - via USB client port, 4-7
  - panel mounting, 2-4
  - physical specifications, A-1
  - pin assignments, D-1
    - RS232, D-1
    - RS485, D-2
  - power connector (figure), 2-3
  - power receptor (figure), 2-3
  - power specifications, A-4
  - safety
    - information, 2-1
    - specifications, A-5

- screen rotation, 3-1
- specifications, A-1
- storage, 1-2
- system configuration, 3-1
- system font size, 3-1
- system kernel specifications, A-2
- system setup, 2-2
- touchscreen
  - calibration, 2-3, 3-2
  - specifications, A-3
- Waste Electrical and Electronic Equipment specifications, A-6
- watchdog timer programming, B-1
  - DeviceIOControl, B-1
- Windows CE .NET, 4-1
  - networking, 4-5
- training and certification (NI resources), E-1
- troubleshooting (NI resources), E-1

## W

- Waste Electrical and Electronic Equipment
  - compliance specifications, A-6
- watchdog, 4-2
- watchdog timer programming, B-1
  - DeviceIOControl, B-1
  - programming example, B-5

- Web resources, E-1
- Windows CE .NET, 4-1
  - ActiveSync, 4-3
  - Bright.exe, 4-4
  - Buzzer.exe, 4-4
  - Contrast.exe, 4-5
  - Iesample.exe, 4-5
  - networking, 4-5
  - NotepadPlus, 4-4
  - Reboot.exe, 4-5
  - Registry Editor, 4-3
  - Registry Saver, 4-3
  - RegSave.exe, 4-5
  - Remote Display Application, 4-4
  - Screen.exe, 4-5
  - soft keyboard, 4-1
  - tools, 4-3
- TPC Configurator, 4-1, 4-4
  - General tab, 4-2
  - Misc tab, 4-2
  - Network tab, 4-2
  - watchdog, 4-2
- TPC utilities, 4-1
- TPC Version Information, 4-4