

# NI 9211 Calibration Procedure

This document contains information about calibrating the National Instruments 9211 module using NI-DAQmx. This calibration procedure is intended for metrology labs.

This document does not discuss programming techniques or compiler configuration. The NI-DAQmx driver contains online help files that have compiler-specific instructions and detailed function explanations. You can install these help files when you install NI-DAQmx on the calibration computer.

The NI 9211 should be calibrated at a regular interval as defined by the measurement accuracy requirements of your application. National Instruments recommends that you routinely perform a complete calibration at least once every year. You can shorten this interval based on the accuracy demands of your application or requirements of your processes. Adjusting the calibration constants must be done by a factory calibration at NI.

## Contents

---

Conventions .....	2
Software and Documentation Requirements.....	2
Software .....	2
Documentation.....	3
Calibration Requirements .....	4
Test Equipment .....	4
Test Conditions .....	4
Calibration Process .....	4
Calibration Process Overview .....	4
Initial Setup.....	5
Verification Procedure .....	5
Analog Input Gain Verification.....	6
Analog Input Offset Verification.....	9
Specifications .....	12
Device Test Limits.....	13
Using the Tables .....	13
Range .....	13

Test Point.....	13
1-Year Limits .....	13
Where to Go for Support .....	14

## Conventions

---

The following conventions appear in this manual:

» The » symbol leads you through nested menu items and dialog box options to a final action. The sequence **File»Page Setup»Options** directs you to pull down the **File** menu, select the **Page Setup** item, and select **Options** from the last dialog box.



This icon denotes a note, which alerts you to important information.

**bold**

Bold text denotes items that you must select or click in the software, such as menu items and dialog box options. Bold text also denotes parameter names and hardware labels.

*italic*

Italic text denotes variables, emphasis, a cross-reference, or an introduction to a key concept. Italic text also denotes text that is a placeholder for a word or value that you must supply.

monospace

Monospace text denotes text or characters that you should enter from the keyboard, sections of code, programming examples, and syntax examples. This font is also used for the proper names of disk drives, paths, directories, programs, subprograms, subroutines, device names, functions, operations, variables, filenames, and extensions.

## Software and Documentation Requirements

---

This section describes the software and documentation required for calibration.

### Software

Install NI-DAQmx 8.1 or later on the calibration computer. NI-DAQmx includes high-level function calls to simplify the task of writing software to calibrate devices. You must have the proper device driver installed on the calibration system before calibrating the device.



**Note** NI recommends that you install the NI-DAQmx driver software before physically installing the NI 9211. NI-DAQmx, available at [ni.com/downloads](http://ni.com/downloads), configures and controls the NI 9211.

NI-DAQmx supports a number of programming languages, including LabVIEW, LabWindows™/CVI™, Microsoft Visual C++ 6.0, Microsoft Visual Basic 6.0, Microsoft .NET, and Borland C++.

You can access the NI-DAQmx header file, `NIDAQmx.h`, like any standard library. You can find examples of how to use the NI-DAQmx driver in the `Program Files\National Instruments\NI-DAQ\Examples` directory.

## Documentation

You might find the following documentation helpful as you write the calibration procedure:

- *NI-DAQmx Help*—This help file contains general information about measurement concepts, key NI-DAQmx concepts, and common applications that apply to all programming environments. To access this help file, select **Start»All Programs»National Instruments»NI-DAQ»NI-DAQmx Help**.
- *NI-DAQmx C Reference Help*—This help file contains C reference and general information about measurement concepts. To access this help file, select **Start»All Programs»National Instruments»NI-DAQ»NI-DAQmx C Reference Help**.
- *DAQ Getting Started Guide* for NI-DAQ 8.0 or later—This guide describes how to install NI-DAQmx for Windows software and NI-DAQmx-supported DAQ devices, and how to confirm that your device is operating properly. To access this guide, select **Start»All Programs»National Instruments»NI-DAQ»DAQ Getting Started Guide**.



**Note** The documents above are installed with NI-DAQmx. You can also download the latest versions from the NI Web site at [ni.com/manuals](http://ni.com/manuals).

- *NI 9211 Operating Instructions*— This document contains information about specific device features. You can download the latest version of this document from the NI Web site at [ni.com/manuals](http://ni.com/manuals).

# Calibration Requirements

---

## Test Equipment

National Instruments recommends that you use the following equipment for calibrating the NI 9211:

- Fluke 5700A calibrator. If that instrument is unavailable, use a high-precision voltage source with an accuracy of at least 10 ppm and an output impedance of less than or equal to 50  $\Omega$ .
- NI cDAQ-9172 chassis.

## Test Conditions

Follow these guidelines to optimize the connections and the environment:

- Keep connections to the device as short as possible. Long cables and wires act as antennae, picking up extra noise that can affect measurements.
- Use shielded copper wire for all cable connections to the device. Use twisted-pair wire to eliminate noise and thermal offsets.
- Maintain an ambient temperature of  $23 \pm 10$  °C. The device temperature will be greater than the ambient temperature.
- Keep relative humidity below 80%.
- Allow a warm-up time of at least 10 minutes to ensure that the measurement circuitry is at a stable operating temperature.

## Calibration Process

---

This section provides instructions for verifying the NI 9211.

### Calibration Process Overview

The calibration process consists of the following steps:

1. *Initial Setup*—Configure the device in NI-DAQmx.
2. *Verification Procedure*—Verify the existing operation of the device. This step confirms whether the device was operating within its specified range prior to calibration.
3. *Adjustment*—Submit the device to NI for a factory calibration to adjust the calibration constants.

The first two steps are explained in the following sections.

## Initial Setup

You must configure the device in Measurement & Automation Explorer (MAX) to communicate with NI-DAQmx.

Complete the following steps to configure a device in MAX:

1. Install the NI-DAQmx driver software.
2. Make sure that no power is connected to the module terminals. If the system is in a nonhazardous location, the chassis power can be on when you install the module.
3. Insert the module into an available slot in the cDAQ-9172 chassis.
4. Launch MAX.
5. Right-click the device name and select **Self-Test** to ensure that the device is working properly.



**Note** When a device is configured with MAX, it is assigned a device name. Each function call uses this device name to determine which DAQ device to calibrate. This document uses `dev1` to refer to the device name. In the following procedures, use the device name as it appears in MAX.

## Verification Procedure

Verification determines how well the device is meeting its specifications. By completing this procedure, you can see how the device has drifted over time, which helps you determine the appropriate calibration interval for your application. The tables in the [Device Test Limits](#) section show all acceptable settings for the device type. Throughout the verification process, use Tables 4 and 5 to determine if the device is operating within its specified range prior to calibration. You must perform verification on all analog input channels.

## Analog Input Gain Verification

Complete the following steps to test the performance of the analog input gain of the device:

1. Refer to Table 1 for a list of the NI connection accessories for the NI 9211 and instructions on connecting the calibrator to the device.

**Table 1.** NI Connection Accessories

Device	Connection Accessory	Connection Instructions
NI 9211	NI 9932 Strain relief & high voltage screw terminal connector	Connect the positive output of the calibrator to all positive terminals (pins 0, 2, 4, and 6) and the negative output of the calibrator to all negative terminals (pins 1, 3, 5, and 7) and COM (pin 9). If the calibrator has a guard connection, connect that terminal to COM instead of connecting COM to the negative output.

2. Set the calibrator voltage to a Test Point value indicated in Table 4. NI recommends that you verify all values, although you can save time by verifying only the values used in your application.
3. If you use C function calls, create a task using `DAQmxCreateTask`, as shown in the following table. If you use LabVIEW, skip this step. The task is created in step 4 in LabVIEW.

NI-DAQmx Function Call	LabVIEW Block Diagram
Call <code>DAQmxCreateTask</code> with the following parameters: <b>taskName:</b> <code>AIVerificationTask</code> <b>taskHandle:</b> <code>&amp;taskHandle</code>	LabVIEW does not require this step.

4. Create and configure an AI voltage channel through NI-DAQmx using DAQmxCreateAIVoltageChan (DAQmx Create Virtual Channel VI), as shown in the following table. Use Table 4 to determine the minimum and maximum values for the device.

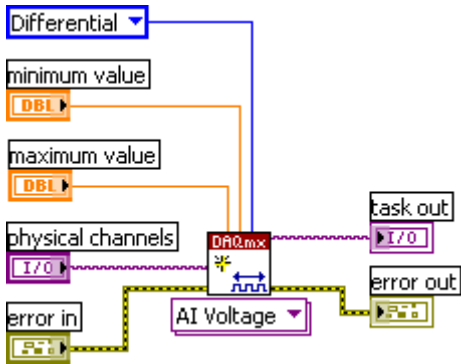
NI-DAQmx Function Call	LabVIEW Block Diagram
<p>Call DAQmxCreateAIVoltageChan with the following parameters:</p> <p><b>taskHandle:</b> taskHandle <b>physicalChannels:</b> dev1/ai0 <b>nameToAssignToChannel:</b> <i>myVoltageChannel</i> <b>terminalConfig:</b> DAQmx_Val_Cfg_Default <b>minVal:</b> -0.08 <b>maxVal:</b> 0.08 <b>units:</b> DAQmx_Val_Volts <b>customScaleName:</b> NULL</p>	 <p>The LabVIEW block diagram shows the DAQmxCreateAIVoltageChan VI. It has several input controls: a dropdown menu set to 'Differential', two numeric input fields for 'minimum value' and 'maximum value' (both with DBL data type), a 'physical channels' control set to 'dev1/ai0', and an 'error in' control. The VI is connected to a 'task out' control, an 'error out' control, and a 'Sample Clock' VI. The 'Sample Clock' VI is also connected to an 'error in' control.</p>

5. Configure the timing properties for the voltage acquisition using DAQmxCfgSampClkTiming (DAQmx Timing VI), as shown in the following table.

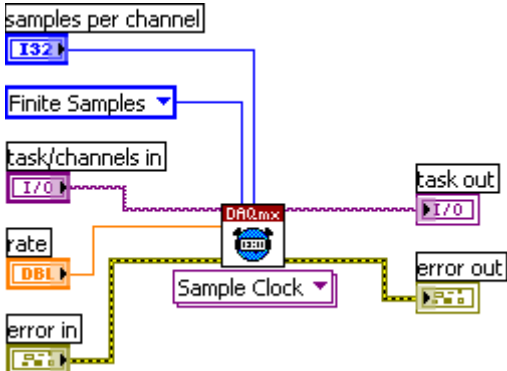
NI-DAQmx Function Call	LabVIEW Block Diagram
<p>Call DAQmxCfgSampClkTiming with the following parameters:</p> <p><b>taskHandle:</b> taskHandle <b>source:</b> NULL <b>rate:</b> 7.14 <b>activeEdge:</b> DAQmx_Val_Rising <b>sampleMode:</b> DAQmx_Val_FiniteSamps <b>sampsPerChan:</b> 50</p>	 <p>The LabVIEW block diagram shows the DAQmxCfgSampClkTiming VI. It has several input controls: a numeric input field for 'samples per channel' (set to 50), a dropdown menu set to 'Finite Samples', a 'task/channels in' control, a 'rate' control (set to 7.14), and an 'error in' control. The VI is connected to a 'task out' control, an 'error out' control, and a 'Sample Clock' VI. The 'Sample Clock' VI is also connected to an 'error in' control.</p>

- Enable autozero through NI-DAQmx using `DAQmxSetChanAttribute` (DAQmx Channel Property Node), as shown in the following table.

NI-DAQmx Function Call	LabVIEW Block Diagram
Call <code>DAQmxSetChanAttribute</code> with the following parameters: <b>taskHandle:</b> taskHandle <b>channel:</b> "" <b>Attribute:</b> <code>DAQmx_AI_AutoZeroMode</code> <b>Value (Autozero on):</b> 10164	<p>The diagram shows a 'DAQmx Channel' block with a dropdown menu set to 'AI.AutoZeroMode'. A 'Every Sample' trigger is connected to the block.</p>

- Start the acquisition using `DAQmxStartTask` (DAQmx Start Task VI), as shown in the following table.

NI-DAQmx Function Call	LabVIEW Block Diagram
Call <code>DAQmxStartTask</code> with the following parameter: <b>taskHandle:</b> taskHandle	<p>The diagram shows a 'DAQmx' block with 'task/channels in' and 'error in' inputs, and 'task out' and 'error out' outputs. The 'task out' output is connected to an 'I/O' block.</p>

- Acquire 50 points of voltage data using `DAQmxReadAnalogF64` (DAQmx Read VI), as shown in the following table.

NI-DAQmx Function Call	LabVIEW Block Diagram
Call <code>DAQmxReadAnalogF64</code> with the following parameters: <b>taskHandle:</b> taskHandle <b>numSampsPerChan:</b> -1 <b>timeout:</b> 10.0 <b>fillMode:</b> <code>DAQmx_Val_GroupByChannel</code> <b>readArray:</b> data <b>arraySizeInSamples:</b> 50 <b>sampsPerChanRead:</b> &read <b>reserved:</b> NULL	<p>The diagram shows a 'DAQmx' block with 'task/channels in' and 'error in' inputs, and 'task out' and 'error out' outputs. The 'task out' output is connected to an 'I/O' block. The 'error out' output is connected to an 'error in' block. The 'data' output is connected to a 'data' block. The 'error in' block is connected to an 'error out' block. The 'data' block is connected to an 'Analog 1D DBL 1Chan NSamp' block. The 'error out' block is connected to an 'error in' block.</p>

9. Average the voltage values that you acquired. Compare the resulting average to the Upper Limit and Lower Limit values listed in Table 4. If the result is between these values, the device passes the test.
10. Clear the acquisition using DAQmxClearTask (DAQmx Clear Task VI), as shown in the following table.

NI-DAQmx Function Call	LabVIEW Block Diagram
Call DAQmxClearTask with the following parameter: <b>taskHandle:</b> taskHandle	

11. Repeat steps 3 through 10 for all channels and all values.
12. Disconnect the calibrator from the device.

## Analog Input Offset Verification

Complete the following steps to test the performance of the analog input offset of the device:

1. Use a copper wire to connect a 0  $\Omega$  short circuit to the device between the positive terminals, the negative terminals, and COM.
2. If you use C function calls, create a task using DAQmxCreateTask, as shown in the following table. If you use LabVIEW, skip this step. The task is created in step 3 in LabVIEW.

NI-DAQmx Function Call	LabVIEW Block Diagram
Call DAQmxCreateTask with the following parameters: <b>taskName:</b> <i>AIVerificationTask</i> <b>taskHandle:</b> &taskHandle	LabVIEW does not require this step.

3. Create and configure an AI voltage channel through NI-DAQmx using DAQmxCreateAIVoltageChan (DAQmx Create Virtual Channel VI), as shown in the following table. Use Table 5 to determine the minimum and maximum values for the device.

NI-DAQmx Function Call	LabVIEW Block Diagram
<p>Call DAQmxCreateAIVoltageChan with the following parameters:</p> <p><b>taskHandle:</b> taskHandle  <b>physicalChannels:</b> dev1/ai0  <b>nameToAssignToChannel:</b> myVoltageChannel  <b>terminalConfig:</b> DAQmx_Val_Cfg_Default  <b>minVal:</b> -0.08  <b>maxVal:</b> 0.08  <b>units:</b> DAQmx_Val_Volts  <b>customScaleName:</b> NULL</p>	

4. Configure the timing properties for the voltage acquisition using DAQmxCfgSampClkTiming (DAQmx Timing VI), as shown in the following table.

NI-DAQmx Function Call	LabVIEW Block Diagram
<p>Call DAQmxCfgSampClkTiming with the following parameters:</p> <p><b>taskHandle:</b> taskHandle  <b>source:</b> NULL  <b>rate:</b> 7.14  <b>activeEdge:</b> DAQmx_Val_Rising  <b>sampleMode:</b> DAQmx_Val_FiniteSamps  <b>sampsPerChan:</b> 50</p>	

- Set autozero through NI-DAQmx using DAQmxSetChanAttribute (DAQmx Channel Property Node), as shown in the following table. Use Table 5 to determine when to set autozero to Every Sample or None.

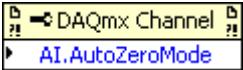
NI-DAQmx Function Call	LabVIEW Block Diagram
Call DAQmxSetChanAttribute with the following parameters: <b>taskHandle:</b> taskHandle <b>channel:</b> "" <b>Attribute:</b> DAQmx_AI_AutoZeroMode <b>Value (Autozero on):</b> 10164 <b>Value (Autozero off):</b> 10230	

- Start the acquisition using DAQmxStartTask (DAQmx Start Task VI), as shown in the following table.

NI-DAQmx Function Call	LabVIEW Block Diagram
Call DAQmxStartTask with the following parameter: <b>taskHandle:</b> taskHandle	

- Acquire 50 points of voltage data using DAQmxReadAnalogF64 (DAQmx Read VI), as shown in the following table.

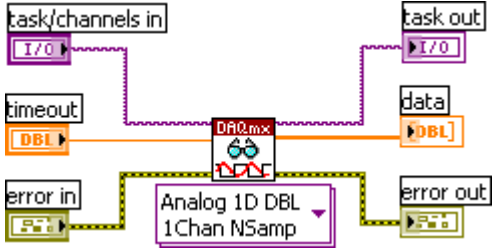
NI-DAQmx Function Call	LabVIEW Block Diagram
Call DAQmxReadAnalogF64 with the following parameters: <b>taskHandle:</b> taskHandle <b>numSampsPerChan:</b> -1 <b>timeout:</b> 10.0 <b>fillMode:</b> DAQmx_Val_GroupByChannel <b>readArray:</b> data <b>arraySizeInSamples:</b> 50 <b>sampsPerChanRead:</b> &read <b>reserved:</b> NULL	

8. Average the voltage values that you acquired. Compare the resulting average to the Upper Limit and Lower Limit values listed in Table 5. If the result is between these values, the device passes the test.
9. Clear the acquisition using DAQmxClearTask (DAQmx Clear Task VI), as shown in the following table.

NI-DAQmx Function Call	LabVIEW Block Diagram
Call DAQmxClearTask with the following parameter: <b>taskHandle:</b> taskHandle	

10. Repeat steps 2 through 9 for all channels and all values.

## Specifications

The values in the following table are based on calibrated scaling coefficients, which are stored in the onboard EEPROM. The following calibration specifications are for  $23 \pm 10$  °C.

**Table 2.** NI 9211 Accuracy

Gain Error	Offset Error
0.05%	20 $\mu$ V



**Note** The Device Test Limits in Tables 4 and 5 include an uncertainty of up to 50  $\Omega$  output impedance. Use Table 3 to add additional uncertainty if you use a calibrator with an output impedance of greater than 50  $\Omega$ .

**Table 3.** Additional Errors from Output Impedance

Gain Error	Offset Error
0.05 ppm/ $\Omega$	0.07 $\mu$ V ppm/ $\Omega$

# Device Test Limits

Tables 4 and 5 list the specifications that the NI 9211 meets if it has been one year between calibrations.

## Using the Tables

The following definitions describe how to use the information from Tables 4 and 5.

### Range

*Range* refers to the minimum or maximum voltage range of an input signal.

### Test Point

The *Test Point* is the voltage value that is input or output for verification purposes. This value is broken down into two columns—*Location* and *Value*. *Location* refers to where the test value fits within the test range. *Value* refers to the voltage value to be verified. *Max* refers to maximum value, *Min* refers to minimum value, and *Mid* refers to mid-scale.

### 1-Year Limits

The *1-Year Limits* column contains the *Upper Limits* and *Lower Limits* for the test point value. That is, when the device is within its 1-year calibration interval, the test point value should fall between these upper and lower limit values.

**Table 4.** NI 9211 Analog Input Values for Gain Verification

Range (V)		Test Point		1-Year Limits	
Minimum	Maximum	Location	Value (V)	Lower Limit (V)	Upper Limit (V)
-0.080	0.080	Max	0.075000	0.0749425	0.0750575
-0.080	0.080	Min	-0.075000	-0.0750575	-0.0749425

**Table 5.** NI 9211 Analog Input Values for Offset Verification

Range (V)		Test Point		1-Year Limits		Autozero Mode
Minimum	Maximum	Location	Value (V)	Lower Limit (V)	Upper Limit (V)	
-0.080	0.080	Mid	0.000000	-0.0000200	0.0000200	Every Sample
-0.080	0.080	Mid	0.000000	-0.0000200	0.0000200	None

# Where to Go for Support

---

The National Instruments Web site is your complete resource for technical support. At [ni.com/support](http://ni.com/support) you have access to everything from troubleshooting and application development self-help resources to email and phone assistance from NI Application Engineers.

National Instruments corporate headquarters is located at 11500 North Mopac Expressway, Austin, Texas, 78759-3504. National Instruments also has offices located around the world to help address your support needs. For telephone support in the United States, create your service request at [ni.com/support](http://ni.com/support) and follow the calling instructions or dial 512 795 8248. For telephone support outside the United States, contact your local branch office:

Australia 1800 300 800, Austria 43 0 662 45 79 90 0,  
Belgium 32 0 2 757 00 20, Brazil 55 11 3262 3599,  
Canada 800 433 3488, China 86 21 6555 7838,  
Czech Republic 420 224 235 774, Denmark 45 45 76 26 00,  
Finland 385 0 9 725 725 11, France 33 0 1 48 14 24 24,  
Germany 49 0 89 741 31 30, India 91 80 41190000,  
Israel 972 0 3 6393737, Italy 39 02 413091, Japan 81 3 5472 2970,  
Korea 82 02 3451 3400, Lebanon 961 0 1 33 28 28,  
Malaysia 1800 887710, Mexico 01 800 010 0793,  
Netherlands 31 0 348 433 466, New Zealand 0800 553 322,  
Norway 47 0 66 90 76 60, Poland 48 22 3390150,  
Portugal 351 210 311 210, Russia 7 495 783 68 51,  
Singapore 1800 226 5886, Slovenia 386 3 425 42 00,  
South Africa 27 0 11 805 8197, Spain 34 91 640 0085,  
Sweden 46 0 8 587 895 00, Switzerland 41 56 200 51 51,  
Taiwan 886 02 2377 2222, Thailand 662 278 6777,  
Turkey 90 212 279 3031, United Kingdom 44 0 1635 523545

National Instruments, NI, ni.com, and LabVIEW are trademarks of National Instruments Corporation. Refer to the *Terms of Use* section on [ni.com/legal](http://ni.com/legal) for more information about National Instruments trademarks. Other product and company names mentioned herein are trademarks or trade names of their respective companies. For patents covering National Instruments products, refer to the appropriate location: **Help»Patents** in your software, the `patents.txt` file on your CD, or [ni.com/patents](http://ni.com/patents).