

INSTALLATION GUIDE

Installing Your PCI-GPIB, NI PCIe-GPIB, PXI-GPIB, or PMC-GPIB and NI-488.2™ for Solaris

This document describes how to install and configure your GPIB hardware and NI-488.2 software. Refer to the section that describes the installation for your particular board. Other documentation, including the software reference manual, is available on your NI-488.2 software for Solaris CD in the `\documentation` folder.

Before you install your GPIB controller, consult the manual that came with your workstation for specific instructions and warnings. You must have superuser privileges to install the hardware and software.

Installing the PCI-GPIB or NI PCIe-GPIB



Caution Electrostatic discharge can damage several components on your GPIB board. To avoid electrostatic damage when you handle the module, touch the antistatic plastic package to a metal part of your computer chassis before you remove the board from the package.

Complete the following steps to install the PCI-GPIB or NI PCIe-GPIB.

1. Log on as superuser. To become a superuser, type `su root` and enter the root password.
2. Shut down your system by typing the following commands at the command line prompt:

```
sync; sync; shutdown
```
3. Power off your computer after it has shut down. Keep the computer plugged in so that it remains grounded while you install the GPIB board.
4. Remove the top cover (or other access panels) to give yourself access to the computer expansion slots.
5. Find an unused PCI or PCI Express slot in your computer.
6. Remove the corresponding slot cover.
7. Insert the GPIB board into the slot with the GPIB connector sticking out of the opening on the back panel, as shown in Figure 1. It might be a tight fit, but do *not* force the board into place.
8. Replace the top cover (or the access panel to the PCI or PCI Express slot).
9. Power on your computer. The GPIB interface board is now installed.

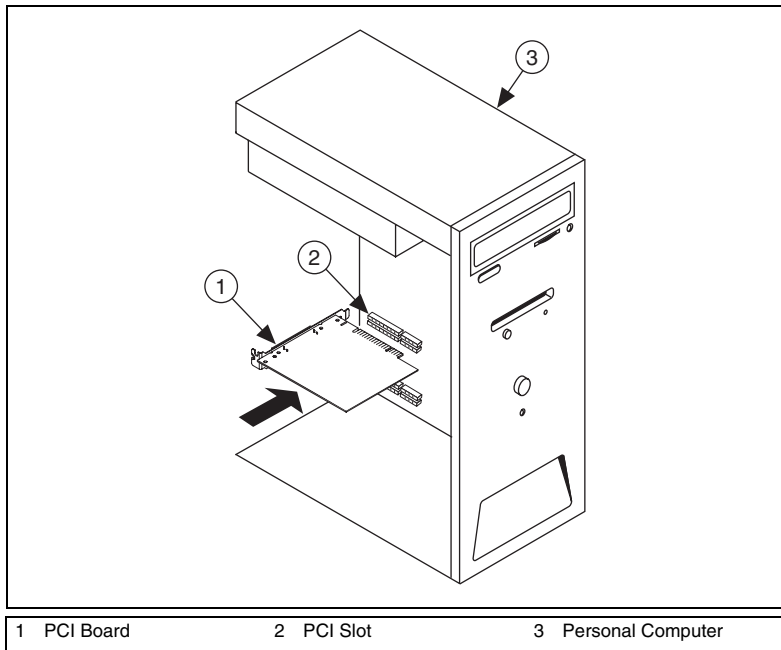

Figure 1. Installing the PCI-GPIB and NI PCIe-GPIB (PCI-GPIB Shown)

Installing the PXI-GPIB



Caution Electrostatic discharge can damage several components on your GPIB board. To avoid electrostatic damage when you handle the module, touch the antistatic plastic package to a metal part of your system chassis before you remove the board from the package.

Complete the following steps to install the PXI-GPIB.

1. Log on as superuser. To become a superuser, type `su root` and enter the root password.
2. Shut down your system by typing the following commands at the command line prompt:

```
sync; sync; shutdown
```
3. Power off your PXI or CompactPCI chassis after it has shut down. Keep the chassis plugged in so that it remains grounded while you install the PXI-GPIB.
4. Choose an unused PXI or CompactPCI peripheral slot. For maximum performance, the PXI-GPIB has an onboard DMA controller that can only be used if the board is installed in a slot that supports bus master cards. National Instruments recommends installing the PXI-GPIB in such a slot. If you install the board in a non-bus master slot, you must disable the PXI-GPIB onboard DMA controller using the board-level call `ibdma`. Refer to the *NI-488.2M Software Reference Manual* for a complete description of `ibdma`.

5. Remove the filler panel for the peripheral slot you have chosen.
6. Touch a metal part on your chassis to discharge any static electricity that might be on your clothes or body.
7. Insert the PXI-GPIB into the selected slot. Use the injector/ejector handle to fully inject the device into place. Figure 2 shows how to install the PXI-GPIB into a PXI or CompactPCI chassis.
8. Screw the front panel of the PXI-GPIB to the front-panel mounting rail of the PXI or CompactPCI chassis.
9. Power on your PXI or CompactPCI chassis. The PXI-GPIB interface board is now installed.

Installing the PMC-GPIB



Caution Electrostatic discharge can damage several components on your GPIB board. To avoid electrostatic damage when you handle the module, touch the antistatic plastic package to a metal part of your computer chassis before you remove the board from the package.

Complete the following steps to install the PMC-GPIB.

1. Log on as superuser. To become a superuser, type `su root` and enter the root password.
2. Shut down your system by typing the following commands at the command line prompt:

```
sync ; sync ; shutdown
```
3. Power off your system.
4. Find an unused PMC slot in your system. You may need to remove the host from the system to access the slot.
5. Remove the corresponding slot filler panel from the host.
6. Touch a metal part on your chassis to discharge any static electricity that might be on your clothes or body.
7. Insert the PMC-GPIB into the slot as shown in Figure 3. It might be a tight fit, but do *not* force the board into place.
8. Use the mounting hardware provided to fasten the PMC-GPIB to the host.
9. Reinstall the host, if you removed it to install the PMC-GPIB.
10. Power on your system. The PMC-GPIB interface board is now installed.

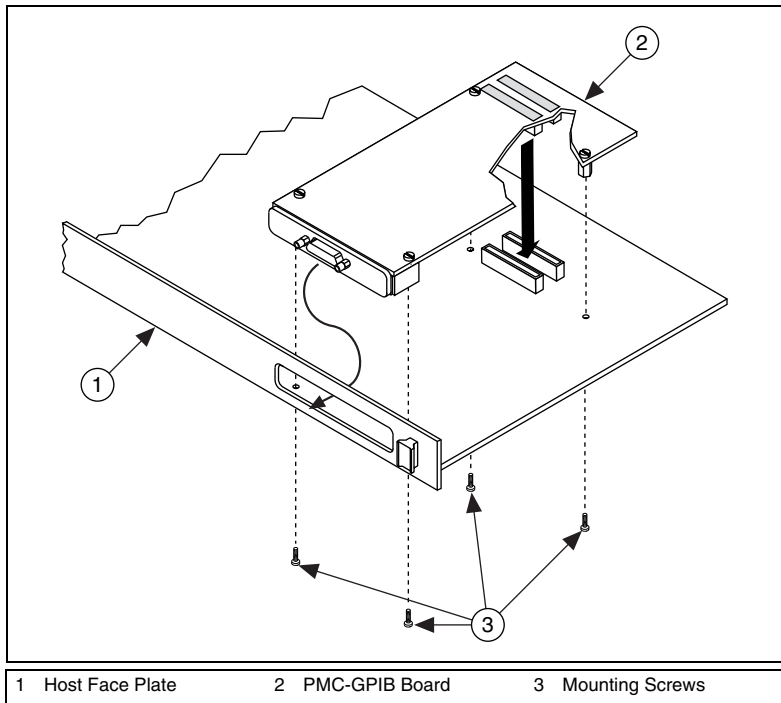

Figure 3. Installing the PMC-GPIB

Installing NI-488.2

Complete the following steps to install NI-488.2 for Solaris.

1. Insert the NI-488.2 for Solaris installation CD-ROM.
2. You must have superuser privileges before you can install NI-488.2 for Solaris. If you are not already a superuser, type `su root` and enter the root password.
3. Add NI-488.2 to the operating system by doing the following:
 - a. The CD automatically mounts as soon as you insert the CD. If this feature is disabled on your workstation, you must manually mount your CD-ROM device.
 - b. Enter the following command to add NI-488.2 to your system:

```
/usr/sbin/pkgadd -d /cdrom/cdrom0 NIPcigpib
```
4. Follow the instructions on your screen to complete the installation.

Configuring the Software with `ibconf` (Optional)

`ibconf` is an interactive utility you can use to examine or modify the configuration of the driver. You might want to run `ibconf` to change the settings of the software parameters. You must have superuser privilege to run `ibconf`.

`ibconf` is largely self explanatory and contains help screens that explain all commands and options. For more information on using `ibconf`, refer to the *NI-488.2M Software Reference Manual*.

Complete the following steps to change the default parameters of your NI-488.2 software. The driver should not be in use while you run `ibconf`.

1. Log on as superuser (`root`).
2. Type the following command to start `ibconf`:

```
ibconf
```

After you have installed and configured the software, you should verify the installation. Refer to the *Verify the Installation* section.

Removing NI-488.2 (Optional)

If you ever decide to stop using your PCI-GPIB, PXI-GPIB, or PMC-GPIB, you can remove the board and the NI-488.2 software. To remove NI-488.2 from the kernel configuration, you must have superuser privilege and the driver must not be in use. Enter the following command to unload the software:

```
pkgrm NIpcigpib
```

Verify the Installation

This section describes how to verify the software installation.

Verifying the System Boot Messages

If a message in the following format displays on the console or in the command tool window during software installation, the driver has established communication with the hardware device and recognized it.

NI-488.2 GPIB Device Driver, Version 2.x
Copyright (c) 2003 National Instruments Corp.
All Rights Reserved.

National Instruments PCI-GPIB (gpibx, slot y, S/N nnn) XXXXXXXX

where *nnn* is the serial number of the board; and *XXXXXXXX* could either be blank, indicating the driver is capable of DMA I/O transfers, or ***** NON-DMA *****, indicating the driver is not capable of DMA I/O transfers.

Running the Software Installation Test

The software installation test has two parts: `ibtsta` and `ibtstb`.

- `ibtsta` checks for correct nodes `/dev/gpib` and `/dev/gpib0` and correct access to the device driver.
- `ibtstb` checks for correct DMA and interrupt operation. `ibtstb` requires a GPIB analyzer, such as the National Instruments GPIB analyzer. You can omit this test if an analyzer is not available.

Complete the following steps to run the software verification test.

1. Type the following command to verify the software installation:

```
ibtsta
```

2. If `ibtsta` completes without errors and you have a bus analyzer, connect the bus analyzer to the GPIB board and run `ibtstb` by typing the following command:

```
ibtstb
```

If no error occurs, the NI-488.2 driver is installed correctly. If an error occurs, refer to the [Troubleshooting Error Messages](#) section for troubleshooting information.

Troubleshooting Error Messages

If `ibtsta` fails, the program generates common error messages that appear on your screen. These error messages explain what went wrong when you ran `ibtsta` and describe how you can correct the problem. For example, the following message might appear on your screen if you forgot to disconnect all your GPIB cables:

The fact that the ENOL error was not received when expected indicates the possible presence of other devices on the bus. Please disconnect ALL GPIB cables from the GPIB board, then run this test again.

If you are still unable to run `ibtsta` and/or `ibtstb` successfully after you follow the recommended actions from the error messages, contact National Instruments.

Using NI-488.2 with Solaris

This section helps you get started with NI-488.2 for Solaris.

Using `ibic`

The NI-488.2 software includes the Interface Bus Interactive Control utility, `ibic`. You can use `ibic` to enter NI-488 functions and IEEE 488.2-style functions (also known as NI-488.2 routines) interactively and display the results of the function calls automatically. Without writing an application, you can use `ibic` to do the following:

- Verify GPIB communication with your device quickly and easily
- Become familiar with the commands of your device
- Receive data from your GPIB device

- Learn new NI-488.2 functions and routines before integrating them into your application
- Troubleshoot problems with your application

Enter the following command to run `ibic`:

```
ibic
```

For more information about `ibic`, refer to Chapter 6, *ibic*, of the *NI-488.2M Software Reference Manual*.

Programming Considerations

Depending on the programming language you use to develop your application, you must include certain files, statements, or global variables at the beginning of your application. For example, you must include the header file `sys/ugplib.h` in your source code if you are using C/C++.

You must link the language interface library with your compiled source code. Link the GPIB C language interface library using one of the following commands, where `example.c` is your application name:

```
cc example.c -lgpib
```

or

```
cc example.c -dy -lgpib
```

or

```
cc example.c -dn -lgpib
```

`-dy` specifies dynamic linking, which is the default method. It links the application to `libgpib.so`. `-dn` specifies static linking in the link editor. It links the

application to `libgpib.a`. For more information about compiling and linking, refer to the `man` pages for `cc` and `ld`.

For information about each NI-488 function and IEEE 488.2-style function, choosing a programming method, developing your application, or compiling and linking, refer to the *NI-488.2M Software Reference Manual*.

Common Questions

What is wrong if `ibfind` returns a `-1`?

The driver may not be installed correctly, or the nodes may not have been created when the driver was loaded. Try removing and reinstalling NI-488.2 from the CD-ROM.

Also, the file may require read/write privileges you do not have, or you may have renamed a device. Make sure that the device names in your application program match the device names in `ibconf`.

What information should I have before I call National Instruments?

Have the results of the diagnostic test `ibtsta`. You also should have run `ibic` to try to find the source of your problem.

Does this driver work with 64-bit Solaris?

Yes. NI-488.2 for Solaris works with either 32-bit or 64-bit Solaris. Also, you can create 32-bit or 64-bit applications. The driver installs both 32-bit and 64-bit language interface libraries on the system. For information on using the NI-488.2 language interfaces, refer to the [Using NI-488.2 with Solaris](#) section.

Will my PCI-GPIB, PXI-GPIB, or PMC-GPIB work in a 64-bit slot?

Yes. The current versions of all three boards will work in 32 or 64-bit slots, as well as 3.3V or 5V slots.

Technical Support and Professional Services

Visit the following sections of the National Instruments Web site at ni.com for technical support and professional services:

- **Support**—Online technical support resources at ni.com/support include the following:
 - **Self-Help Resources**—For answers and solutions, visit the award-winning National Instruments Web site for software drivers and updates, a searchable KnowledgeBase, product manuals, step-by-step troubleshooting wizards, thousands of example programs, tutorials, application notes, instrument drivers, and so on.
 - **Free Technical Support**—All registered users receive free Basic Service, which includes access to hundreds of Application Engineers worldwide in the NI Discussion Forums at ni.com/forums. National Instruments Application Engineers make sure every question receives an answer.

For information about other technical support options in your area, visit ni.com/services or contact your local office at ni.com/contact.
- **Training and Certification**—Visit ni.com/training for self-paced training, eLearning virtual classrooms, interactive CDs, and Certification program information. You also can register for instructor-led, hands-on courses at locations around the world.

- **System Integration**—If you have time constraints, limited in-house technical resources, or other project challenges, National Instruments Alliance Partner members can help. To learn more, call your local NI office or visit ni.com/alliance.
- **Declaration of Conformity (DoC)**—A DoC is our claim of compliance with the Council of the European Communities using the manufacturer's declaration of conformity. This system affords the user protection for electronic compatibility (EMC) and product safety. You can obtain the DoC for your product by visiting ni.com/certification.
- **Calibration Certificate**—If your product supports calibration, you can obtain the calibration certificate for your product at ni.com/calibration.

If you searched ni.com and could not find the answers you need, contact your local office or NI corporate headquarters. Phone numbers for our worldwide offices are listed at the front of this manual. You also can visit the Worldwide Offices section of ni.com/niglobal to access the branch office Web sites, which provide up-to-date contact information, support phone numbers, email addresses, and current events.

National Instruments, NI, ni.com, and LabVIEW are trademarks of National Instruments Corporation. Refer to the *Terms of Use* section on ni.com/legal for more information about National Instruments trademarks. Other product and company names mentioned herein are trademarks or trade names of their respective companies. For patents covering National Instruments products, refer to the appropriate location: **Help»Patents** in your software, the `patents.txt` file on your CD, or ni.com/patents.