

## USER GUIDE AND SPECIFICATIONS

# NI SCC-CTR01 Isolated Counter/Timer I/O Module

The NI SCC-CTR01 is a two input and one output isolation module for general-purpose counter/timers on DAQ devices. The gate and source inputs are optically isolated to allow an increased voltage range and protect against common-mode voltages. The inputs also have reverse and overvoltage protection. The output channel is isolated and has advanced short-circuit protection, which allows the circuit to recover automatically 250 ms after a short is removed.

## Conventions

---

The following conventions are used in this guide:

»

The » symbol leads you through nested menu items and dialog box options to a final action. The sequence **File»Page Setup»Options** directs you to pull down the **File** menu, select the **Page Setup** item, and select **Options** from the last dialog box.



This icon denotes a caution, which advises you of precautions to take to avoid injury, data loss, or a system crash. When this symbol is marked on the product, refer to the *Read Me First: Safety and Radio-Frequency Interference* document, shipped with the product, for precautions to take.



This icon denotes a note, which alerts you to important information.



When symbol is marked on a product, it denotes a warning advising you to take precautions to avoid electrical shock.



When symbol is marked on a product, it denotes a component that may be hot. Touching this component may result in bodily injury.

**bold**

Bold text denotes items that you must select in software, such as menu items and dialog box options. Bold text also denotes parameter names.

<i>italic</i>	Italic text denotes variables, emphasis, a cross-reference, or an introduction to a key concept. Italic text also denotes text that is a placeholder for a word or value that you must supply.
monospace	Text in this font denotes text or characters that you should enter from the keyboard, sections of code, programming examples, and syntax examples. This font is also used for the proper names of disk drives, paths, directories, programs, subprograms, subroutines, device names, functions, operations, variables, filenames, and extensions.
NI SC-2345	NI SC-2345 refers to both the NI SC-2345 connector block and the NI SC-2345 with configurable connectors.
SCC	SCC refers to any SCC Series signal-conditioning module.

## What You Need to Get Started

---

To set up and use the NI SCC-CTR01, you need the following items:

- NI SC-2345 with one of the following:
  - SCC-PWR01
  - SCC-PWR02 and the PS01 power supply
  - SCC-PWR03 (requires a 7 to 42 VDC power supply, not included)
- One or more NI SCC-CTR01 modules
- NI SC-2345/2350 Carrier User Manual*, available at [ni.com](http://ni.com)
- NI SCC-CTR01 Isolated Counter/Timer I/O Module User Guide and Specifications*
- SCC Quick Start Guide*, available at [ni.com](http://ni.com)
- Read Me First: Safety and Radio-Frequency Interference*
- SC-2345 Quick Reference Label
- 68-pin E/M Series DAQ device with the following:
  - Documentation
  - 68-pin cable of less than 2 m length
- 1/8 in. flathead screwdriver
- Numbers 1 and 2 Phillips screwdrivers

- Wire insulation strippers
- NI-DAQmx (current version) for Windows Vista/XP/2000



**Note** Mac OS is not supported.

## Related Documentation

---

Each application software package and driver includes information about writing applications for taking measurements and controlling measurement devices. The following references to documents assume you have NI-DAQmx 8.7 or later, and where applicable, version 7.1 or later of the NI application software.

### NI-DAQmx for Windows

The *DAQ Getting Started Guide* describes how to install your NI-DAQmx for Windows software, your NI-DAQmx-supported DAQ device, and how to confirm that your device is operating properly. Select **Start»All Programs»National Instruments»NI-DAQ»DAQ Getting Started Guide**.

The *NI-DAQ Readme* lists which devices are supported by this version of NI-DAQ. Select **Start»All Programs»National Instruments»NI-DAQ»NI-DAQ Readme**.

The *NI-DAQmx Help* contains general information about measurement concepts, key NI-DAQmx concepts, and common applications that are applicable to all programming environments. Select **Start»All Programs»National Instruments»NI-DAQ»NI-DAQmx Help**.



**Note** For information about non-Windows operating system support, refer to [ni.com/info](http://ni.com/info) and enter `rdqld`.

### NI-DAQmx for Linux

The *DAQ Getting Started Guide* describes how to install your NI-DAQmx-supported DAQ device and confirm that your device is operating properly.

The *NI-DAQ Readme for Linux* lists supported devices and includes software installation instructions, frequently asked questions, and known issues.

The *C Function Reference Help* describes functions and attributes.

The *NI-DAQmx for Linux Configuration Guide* provides configuration instructions, templates, and instructions for using test panels.



**Note** All NI-DAQmx documentation for Linux is installed at `/usr/local/natinst/nidaqmx/docs`.

## LabVIEW

If you are a new user, use the *Getting Started with LabVIEW* manual to familiarize yourself with the LabVIEW graphical programming environment and the basic LabVIEW features you use to build data acquisition and instrument control applications. Open the *Getting Started with LabVIEW* manual by selecting **Start»All Programs»National Instruments»LabVIEW»LabVIEW Manuals** or by navigating to the `labview\manuals` directory and opening `LV_Getting_Started.pdf`.

Use the *LabVIEW Help*, available by selecting **Help»Search the LabVIEW Help** in LabVIEW, to access information about LabVIEW programming concepts, step-by-step instructions for using LabVIEW, and reference information about LabVIEW VIs, functions, palettes, menus, and tools. Refer to the following locations on the Contents tab of the *LabVIEW Help* for information about NI-DAQmx:

- **Getting Started»Getting Started with DAQ**—Includes overview information and a tutorial to learn how to take an NI-DAQmx measurement in LabVIEW using the DAQ Assistant.
- **VI and Function Reference»Measurement I/O VIs and Functions**—Describes the LabVIEW NI-DAQmx VIs and properties.
- **Taking Measurements**—Contains the conceptual and how-to information you need to acquire and analyze measurement data in LabVIEW, including common measurements, measurement fundamentals, NI-DAQmx key concepts, and device considerations.

## LabWindows/CVI

The **Data Acquisition** book of the *LabWindows/CVI Help* contains measurement concepts for NI-DAQmx. This book also contains *Taking an NI-DAQmx Measurement in LabWindows/CVI*, which includes step-by-step instructions about creating a measurement task using the DAQ Assistant. In LabWindows™/CVI™, select **Help»Contents**, then select **Using LabWindows/CVI»Data Acquisition**.

The **NI-DAQmx Library** book of the *LabWindows/CVI Help* contains API overviews and function reference for NI-DAQmx. Select **Library Reference»NI-DAQmx Library** in the *LabWindows/CVI Help*.

## Measurement Studio

If you program your NI-DAQmx-supported device in Measurement Studio using Visual C++, Visual C#, or Visual Basic .NET, you can interactively create channels and tasks by launching the DAQ Assistant from MAX or from within Visual Studio .NET. You can generate the configuration code based on your task or channel in Measurement Studio. Refer to the *DAQ Assistant Help* for additional information about generating code. You also can create channels and tasks, and write your own applications in your ADE using the NI-DAQmx API.

For help with NI-DAQmx methods and properties, refer to the NI-DAQmx .NET Class Library or the NI-DAQmx Visual C++ Class Library included in the *NI Measurement Studio Help*. For general help with programming in Measurement Studio, refer to the *NI Measurement Studio Help*, which is fully integrated with the Microsoft Visual Studio .NET help. To view this help file in Visual Studio .NET, select **Measurement Studio» NI Measurement Studio Help**.

To create an application in Visual C++, Visual C#, or Visual Basic .NET, follow these general steps:

1. In Visual Studio .NET, select **File»New»Project** to launch the New Project dialog box.
2. Find the Measurement Studio folder for the language you want to create a program in.
3. Choose a project type. You add DAQ tasks as a part of this step.

## ANSI C without NI Application Software

The *NI-DAQmx Help* contains API overviews and general information about measurement concepts. Select **Start»All Programs»National Instruments»NI-DAQ»NI-DAQmx Help**.

The *NI-DAQmx C Reference Help* describes the NI-DAQmx Library functions, which you can use with National Instruments data acquisition devices to develop instrumentation, acquisition, and control applications. Select **Start»All Programs»National Instruments»NI-DAQ»NI-DAQmx C Reference Help**.

## .NET Languages without NI Application Software

With the Microsoft .NET Framework version 1.1 or later, you can use NI-DAQmx to create applications using Visual C# and Visual Basic .NET without Measurement Studio. You need Microsoft Visual Studio .NET 2003 or Microsoft Visual Studio 2005 for the API documentation to be installed.

The installed documentation contains the NI-DAQmx API overview, measurement tasks and concepts, and function reference. This help is fully integrated into the Visual Studio .NET documentation. To view the NI-DAQmx .NET documentation, go to **Start»Programs»National Instruments»NI-DAQ»NI-DAQmx .NET Reference Help**. Expand **NI Measurement Studio Help»NI Measurement Studio .NET Class Library»Reference** to view the function reference. Expand **NI Measurement Studio Help»NI Measurement Studio .NET Class Library»Using the Measurement Studio .NET Class Libraries** to view conceptual topics for using NI-DAQmx with Visual C# and Visual Basic .NET.

To get to the same help topics from within Visual Studio, go to **Help»Contents**. Select **Measurement Studio** from the **Filtered By** drop-down list and follow the previous instructions.

## Device Documentation and Specifications

NI-DAQmx includes the Device Document Browser, which contains online documentation for supported DAQ, SCXI, and switch devices, such as help files describing device pinouts, features, and operation, and PDF files of the printed device documents. You can find, view, and/or print the documents for each device using the Device Document Browser at any time by inserting the CD. After installing the Device Document Browser, device documents are accessible from **Start»All Programs»National Instruments»NI-DAQ»Browse Device Documentation**.



**Note** You can download these documents at [ni.com/manuals](http://ni.com/manuals).

## Training Courses

If you need more help getting started developing an application with NI products, NI offers training courses. To enroll in a course or obtain a detailed course outline, refer to [ni.com/training](http://ni.com/training).

## Technical Support on the Web

For additional support, refer to [ni.com/support](http://ni.com/support) or [zone.ni.com](http://zone.ni.com).

# Installing the Software

---

Software support for the NI SCC-SCTR01 for Windows Vista/XP/2000 is provided by NI-DAQmx. The *DAQ Getting Started Guide*, which you can download at [ni.com/manuals](http://ni.com/manuals), offers NI-DAQmx users step-by-step instructions for installing software and hardware, configuring channels and tasks, and getting started developing an application.

## Installing Other Software

If you are using other software, refer to the installation instructions that accompany your software.

## Device-Specific Information

---



**Note** For general SCC module installation and signal connection information, and information about the NI SC-2345 carrier, refer to the *SCC Quick Start Guide*, available for download at [ni.com/manuals](http://ni.com/manuals).

## Installing the Module



**Caution** Refer to the *Read Me First: Safety and Radio-Frequency Interference* document before removing equipment covers or connecting/disconnecting any signal wires.



**Note** When using the SCC-CTR01, ground the chassis of the DAQ device.

Plug the NI SCC-CTR01 into either general-purpose counter/timer socket J19 or J20 on the NI SC-2345. When you configure the NI SC-2345 according to the procedure in the *SCC Quick Start Guide*, the NI SC-2345 routes the CTR\_SRC, CTR\_GATE, and CTR\_OUT signals through the module.

# Connecting Signals and Loads to the NI SCC-CTR01

## Inputs (Gate and Source)

The inputs on the NI SCC-CTR01 are referenced to either the ground or the supply of the external device to which they are connected. An optical isolator transfers the externally connected signals to the internal GPCTR SRC or GATE. A current limiter protects the optical isolator. A diode protects against reverse-connected signals. Figure 1 illustrates a single isolated input.

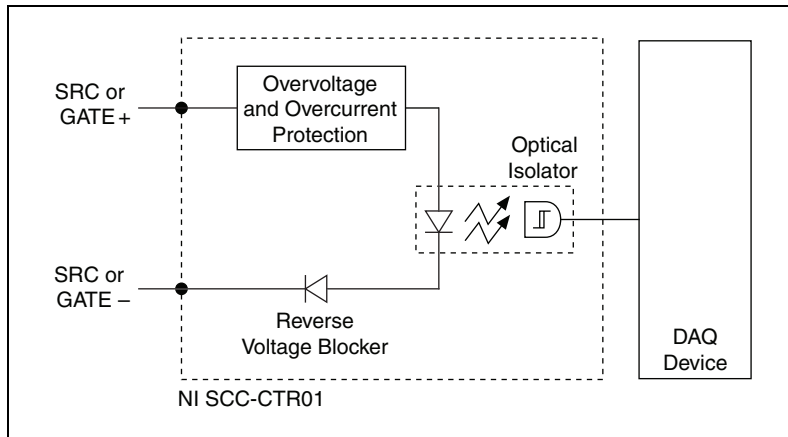

**Figure 1.** Single Isolated Input

Inputs are referenced to either the ground or supply of the external device, depending on whether or not the external device can source the amount of current required by the NI SCC-CTR01 input circuitry. To guarantee a digital HIGH, the minimum amount of current required by the NI SCC-CTR01 inputs is 2.2 mA. The overvoltage and overcurrent protector does not allow the amount of current flowing through the input circuitry to exceed 10 mA.



## Connecting the NI SCC-CTR01

The following sections describe how to connect the NI SCC-CTR01 as referenced to ground and as referenced to the supply.

### Connecting the NI SCC-CTR01 as Referenced to Ground

Connect the external device to the SRC or GATE + pin, and connect the device ground to the SRC or GATE – pin, as shown in Figure 2.

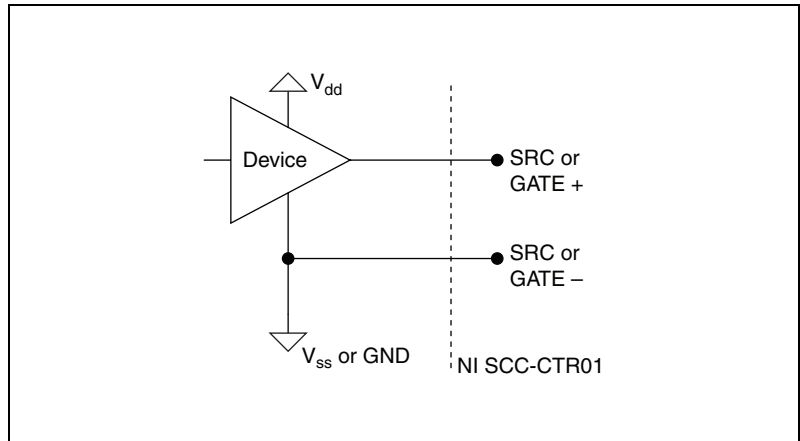

**Figure 2.** Referenced to Ground

## Connecting the NI SCC-CTR01 as Referenced to the Supply

Connect the  $V_{dd}$  on the external device to the NI SCC-CTR01 SRC or GATE + pin, and connect the output of the external device to the SRC or GATE – pin, as shown in Figure 3.

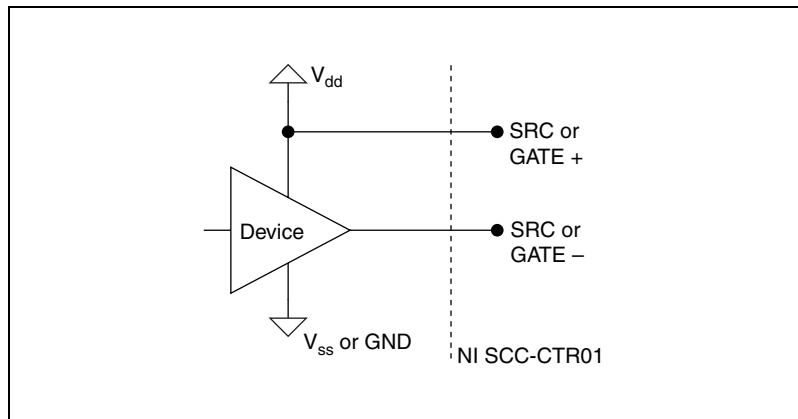

**Figure 3.** Referenced to Supply



**Note** Connecting the NI SCC-CTR01 as referenced to the supply reverses the digital logic. To operate the NI SCC-CTR01 with TTL devices, reference the NI SCC-CTR01 to the supply, as shown in Figure 3.



**Note** When placing a relatively slow rise time signal—such as a 5 V peak sine or triangle wave—on one of the inputs, and a fast rise time, high voltage signal—such as a 400 kHz, 48 V square wave—on the other input, crosstalk between input lines can cause false triggering. You should separate the input wires as much as possible. If you are using an M Series DAQ device, consult the M Series User Manual for information about applying the appropriate digital filter to prevent incorrect measurements.

# Outputs

The outputs on the NI SCC-CTR01 consist of N-channel MOSFETs that are connected as low-side switches. A Schottky diode blocks reverse current flow.

Figure 4 illustrates an NI SCC-CTR01 isolated output.

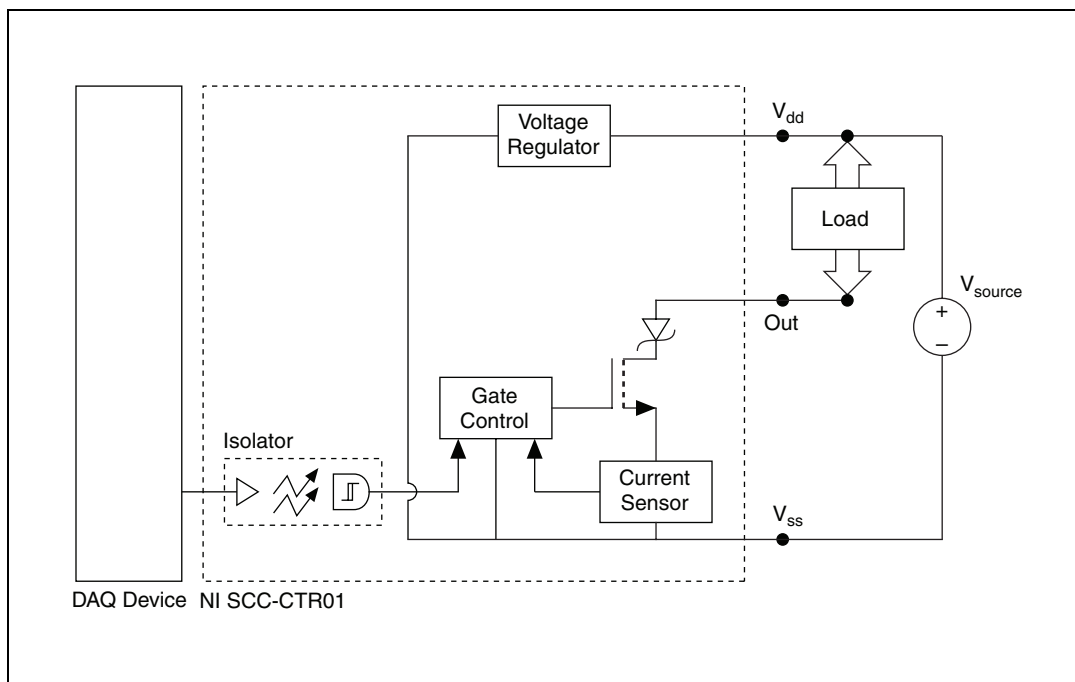

**Figure 4.** Connecting an NI SCC-CTR01 Isolated Output

For the output circuit to function, you must provide 5 to 48 V between  $V_{dd}$  and  $V_{ss}$ . Reverse connections of  $V_{dd}$  and  $V_{ss}$  do not damage the circuit as long as these connections do not exceed 60 VDC, as listed in the [Specifications](#) section.

If the amount of current the MOSFET conducts exceeds a certain level (800 mA, typical)—such as when a short occurs in the load—the MOSFET turns off for 250 ms to protect itself and the load. After this period of time, the output tries to switch on. If the short still exists, it turns off for another 250 ms. This process continues until the overcurrent or short condition is removed, after which switching automatically resumes.



**Note** Add bypass capacitor(s) between  $V_{dd}$  and  $V_{ss}$  at the load to reduce the chances of ringing when the output switches on and off, especially when the connecting wires are longer than 2 m.



**Note** For most DAQ device counters, the default state is LOW, which results in the output MOSFET being switched to ON. If you want to change the default state—for example, to eliminate continuous power dissipation in the load during the idle state—consult your DAQ documentation for information about how to change the default to HIGH and switch the MOSFET to OFF.

## Driving Inductive Loads



**Caution** When the output of the NI SCC-CTR01 is used to drive an inductive load, high voltages will appear suddenly because of the current switching through the inductor. To prevent these high voltages from causing damage to the output circuit or the load, add flyback diodes across your inductive load, as shown in Figure 5.

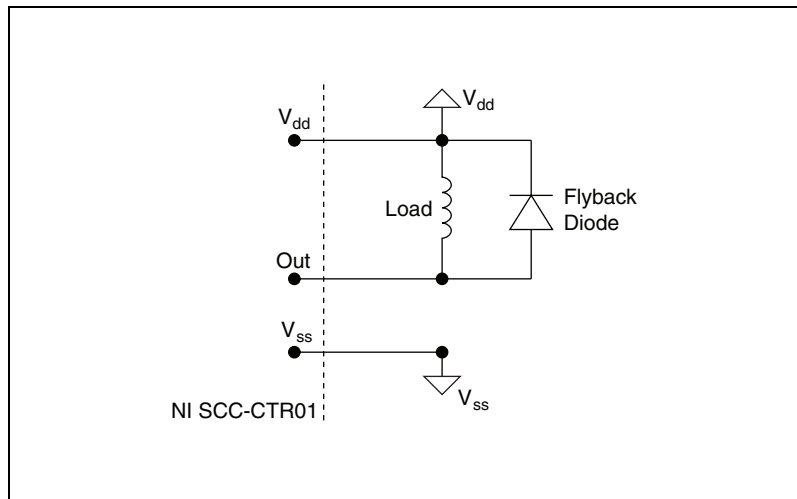

**Figure 5.** Flyback Diodes on Inductive Load



**Caution** Ensure the diode you choose is capable of handling the amount of current the load is holding when the output is ON.

# Theory of Operation

---

## Input (Source and Gate)

### Optical Isolation

The gate and source inputs are isolated from each other and from the NI SCC-CTR01 internal power and ground signals. The isolation barrier protects the NI SCC-CTR01 and other equipment from voltages up to 60 VDC. Common-mode voltages higher than 60 VDC can damage the NI SCC-CTR01 and other equipment. The isolation allows for increased input ranges. The input signal can be varied between 0 VDC and 48 VDC between the + and – terminals. The isolation also protects against ground loops.

### Reverse and Over-voltage Protection

A diode placed between the + and – input terminals provides reverse voltage protection to the NI SCC-CTR01 and other equipment. In addition, the NI SCC-CTR01 is equipped with overvoltage protection and can handle continuous voltages, between the + and – input terminals, up to  $\pm 60$  VDC.

### Frequencies of Operation

Based on the application, the NI SCC-CTR01 may operate at higher than the maximum frequency specified in the [Specifications](#) section. Table 1 lists the typical NI SCC-CTR01 input channel operating rates.

**Table 1.** NI SCC-CTR01 Typical Input Tasks Maximum Rates

Operating Voltage	Counting Edges	Pulse Width Measurement, Semi-Period Measurement	Period Measurement, Frequency Measurement	Position Measurement
5 V	1 MHz	0.6 $\mu$ s	1 MHz	1 MHz
24 V	800 kHz	1 $\mu$ s	800 kHz	800 kHz
48 V	400 kHz	1 $\mu$ s	400 kHz	400 kHz

**Notes:** Typical at 25 °C, 1 meter cable connected to DAQ device.

Measurement accuracy can be improved by adjusting the LOW to HIGH and HIGH to LOW switching times in the software. Refer to the *Theory of Operation* section for more information.

# Output (Out)

## Signal Isolation

The output is isolated from the inputs, and the NI SCC-CTR01 internal power and ground signals. The isolation barrier protects the NI SCC-CTR01 and other equipment from voltages up to 60 VDC. Common-mode voltages higher than 60 VDC can damage the NI SCC-CTR01 and other equipment.

## Increased Range

The voltage range of the output is increased by providing the user access to the power terminals  $V_{dd}$  and  $V_{ss}$ . The user can safely provide 5 to 48 VDC allowing equal scaling of the output.

## Current Limited (Short Circuit Protection)

The NI SCC-CTR01 has advanced short circuit protection. The output is automatically turned off if the output current exceeds a certain limit (800 mA typical, 1.1 A max). The NI SCC-CTR01 tries to reoperate every 250 ms and automatically recovers after the short is removed.

## Reverse and Overvoltage Protection

The NI SCC-CTR01 provides protection for voltages up to  $\pm 60$  VDC between  $V_{dd}$  and  $V_{ss}$  and the output and  $V_{ss}$ .

## Frequencies of Operation

Based on the application, the NI SCC-CTR01 may operate at higher than the maximum frequency specified in the [Specifications](#) section. Table 2 lists typical NI SCC-CTR01 output channel rates.

**Table 2.** NI SCC-CTR01 Output Tasks

Operating Voltage	Frequency Generation	Pulse Generation
5 V	600 kHz	1 $\mu$ s
24 V	500 kHz	1 $\mu$ s
48 V	400 kHz	1 $\mu$ s

**Notes:** Typical at 25 °C, 250  $\Omega$  load, 1 meter cable connected to DAQ device.  
Measurement accuracy can be improved by adjusting the ON and OFF switching times in the software. Refer to the [Theory of Operation](#) section for more information.

## Using the NI SCC-CTR01

The NI SCC-CTR01 is functional in a variety of applications including counting events; pulse width, period, semi-period, position, and frequency measurements; and frequency, pulse, and pulse train generation.

The variation between the LOW to HIGH and the HIGH to LOW propagation delays on the input channels may affect semi-period or pulse-width measurements. Adjusting the measurement by the difference between the LOW to HIGH and the HIGH to LOW propagation delays (typically 30 ns at 5 V operation) minimizes this effect, as illustrated by the following equation for a positive pulse in positive logic:

$$\text{Adjusted Pulse Width} = \text{Actual Measurement} + (\text{LOW to HIGH Delay} - \text{HIGH to LOW Delay}).$$

Example:

If using typical LOW to HIGH and HIGH to LOW propagation delays/relays (180 ns and 150 ns), and the actual measured pulse width is 820 ns, then

$$\text{Adjusted Pulse Width} = 820 \text{ ns} + (180 \text{ ns} - 150 \text{ ns}) = 820 \text{ ns}.$$

The variation between the switching times on the output channel can affect duty cycle generation. Adjusting the output by the difference between the LOW to HIGH (220 ns) time and the HIGH to LOW time (120 ns) minimizes this effect.

$$\text{Adjusted Duty Cycle} = \text{Desired Duty Cycle} + (\text{Low to High} - \text{High to Low Time}) \times \text{Frequency of Generation}.$$

Example:

While using the typical LOW to HIGH and HIGH to LOW times, if the actual desired duty cycle is 0.50 at 400 kHz then:

$$\text{Adjusted Duty Cycle} = 0.50 + (150 \text{ ns} - 500 \text{ ns}) \times 400 \text{ kHz} = 0.36.$$

# Specifications

---

These specifications are typical at 25 °C unless otherwise stated.

## Power

Power requirement.....140 mW max from +5 V rail  
(digital power)

## Isolated Inputs

Number of input channels.....2 (CTR\_SRC, CTR\_GATE)

Input type .....Driven reference to either supply  
or ground (two terminals per  
input)

Maximum input frequency .....400 kHz

Minimum input pulse width .....1  $\mu$ s

Input-to-input, input-to-output,  
and input-to-PC ground isolation .....60 VDC, continuous, verified by a  
620 V<sub>rms</sub> dielectric withstand test,  
5 sec

Input waveform types .....Any

## Voltage

Voltage range.....Up to 48 VDC

Typical ON voltage .....2.5 V

Guaranteed ON voltage .....4.1 V

Guaranteed OFF voltage.....0.8 V

## Current

ON state current.....2.2 mA min, 6 mA typ,  
10 mA max

OFF state current .....0.1 mA max



## Protection

Current limit .....	10 mA max (over operating temperature range)
Reverse and overvoltage .....	±60 VDC max, continuous

## Propagation Delays (for a 5 V Input Signal)

LOW to HIGH .....	180 ns typ
HIGH to LOW .....	150 ns typ

## Isolated Output

Number of output channels .....	1 (CTR_OUT)
Output type.....	Sinking (low-side switch)
Output power requirement .....	5 to 48 VDC (10 mA per channel, typical at 400 kHz)
Load voltage range.....	5 to 48 VDC
Switching current .....	100 mA, max
Inrush current .....	600 mA, max
Maximum output frequency .....	400 kHz
Minimum output pulse width.....	1 $\mu$ s
Output-to-output, output-to-input, and output-to-PC ground isolation .....	60 VDC peak, continuous, verified by a 620 V <sub>rms</sub> dielectric withstand test, 5 sec
Typical switching times (with a 5 V, 100 $\Omega$ load)	
LOW to HIGH .....	150 ns
HIGH to LOW .....	500 ns
Output LOW maximum voltage .....	0.47 V at 10 mA, 0.75 V at 100 mA
Output leakage current when OFF .....	60 $\mu$ A max

## Protection

Short circuit (on output pins).....	0.6 A min, 1.1 A max (stays off after detecting a short circuit and retries to operate every 250 ms, then automatically recovers after removing the short)
Reverse and overvoltage on output and $V_{dd}$ pins .....	$\pm 60$ VDC max, continuous

## Physical Characteristics

Dimensions .....	8.89 cm $\times$ 2.92 cm $\times$ 1.85 cm (3.50 in. $\times$ 1.15 in. $\times$ 0.73 in.)
Mass .....	28.6 g (1.0 oz)
I/O connectors.....	One 20-pin right-angle male connector, one 7-pin screw terminal
Field-wiring diameter .....	28 to 16 AWG

## Environmental

Operating temperature .....	0 to 50 °C
Storage temperature .....	-20 to 70 °C
Humidity .....	10 to 90% RH, noncondensing
Maximum altitude.....	2,000 m
Pollution Degree (indoor use only) .....	2

## Safety

This product is designed to meet the requirements of the following standards of safety for electrical equipment for measurement, control, and laboratory use:

- IEC 61010-1, EN 61010-1
- UL 61010-1, CSA 61010-1



**Note** For UL and other safety certifications, refer to the product label or visit [ni.com/certification](http://ni.com/certification), search by model number or product line, and click the appropriate link in the Certification column.

## Electromagnetic Compatibility

This product is designed to meet the requirements of the following standards of EMC for electrical equipment for measurement, control, and laboratory use:

- EN 61326 EMC requirements; Minimum Immunity
- EN 55011 Emissions; Group 1, Class A
- CE, C-Tick, ICES, and FCC Part 15 Emissions; Class A



**Note** For EMC compliance, operate this device according to product documentation.

## CE Compliance

This product meets the essential requirements of applicable European Directives, as amended for CE marking, as follows:

- 2006/95/EC; Low-Voltage Directive (safety)
- 2004/108/EEC; Electromagnetic Compatibility Directive (EMC)



**Note** Refer to the Declaration of Conformity (DoC) for this product for any additional regulatory compliance information. To obtain the DoC for this product, visit [ni.com/certification](http://ni.com/certification), search by model number or product line, and click the appropriate link in the Certification column.

## Environmental Management

National Instruments is committed to designing and manufacturing products in an environmentally responsible manner. NI recognizes that eliminating certain hazardous substances from our products is beneficial not only to the environment but also to NI customers.

For additional environmental information, refer to the *NI and the Environment* Web page at [ni.com/environment](http://ni.com/environment). This page contains the environmental regulations and directives with which NI complies, as well as other environmental information not included in this document.

## Waste Electrical and Electronic Equipment (WEEE)



**EU Customers** At the end of their life cycle, all products *must* be sent to a WEEE recycling center. For more information about WEEE recycling centers and National Instruments WEEE initiatives, visit [ni.com/environment/weee.htm](http://ni.com/environment/weee.htm).

## 电子信息产品污染控制管理办法（中国 RoHS）



**中国客户** National Instruments 符合中国电子信息产品中限制使用某些有害物质指令 (RoHS)。关于 National Instruments 中国 RoHS 合规性信息, 请登录 [ni.com/environment/rohs\\_china](http://ni.com/environment/rohs_china)。(For information about China RoHS compliance, go to [ni.com/environment/rohs\\_china](http://ni.com/environment/rohs_china).)

# NI SCC-SCTR01 Module Pin Assignments

Figure 6 shows the I/O connector on the bottom of the NI SCC-CTR01.

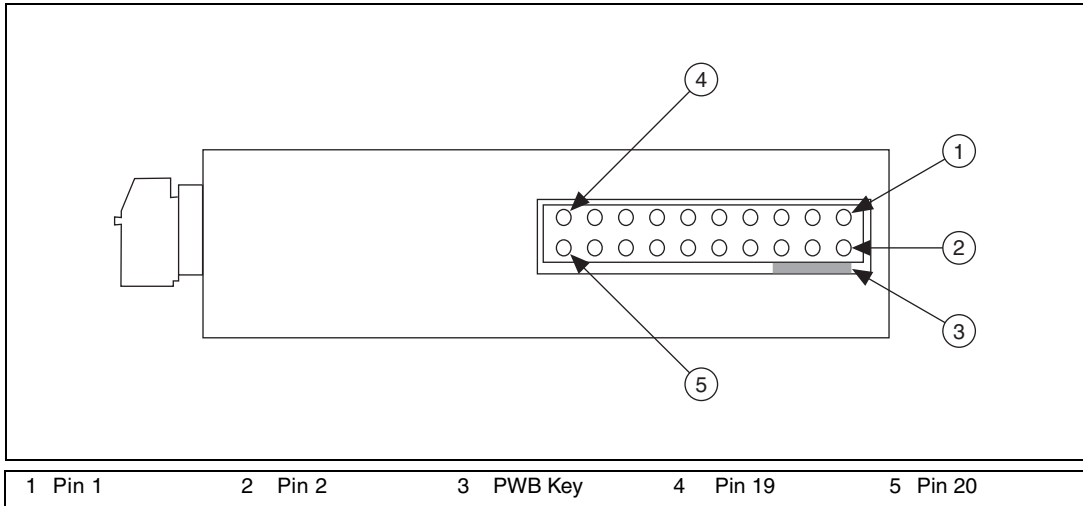

**Figure 6.** SCC Module, Bottom View

Table 3 lists the signal connection corresponding to each pin. GND is the reference for the +5 V supply.

**Table 3.** NI SCC-CTR01 Pin Signal Connections

Pin Number	J19–J20: GPCTR 0	J19–J20: GPCTR 1
1	CTR 0 OUT	CTR 1 OUT
2	—	—
3	PFI 9/CTR 0 GATE	PFI 4/CTR 1 GATE
4	—	—
5	PFI 8/CTR 0 SOURCE	PFI 3/CTR 1 SOURCE
6	—	—
7	—	—
8	—	—
9	+5 V	+5 V
10	GND	GND
11	—	—
12	—	—
13	—	—
14	—	—
15	—	—
16	—	—
17	—	—
18	—	—
19	—	—
20	—	—

National Instruments, NI, ni.com, and LabVIEW are trademarks of National Instruments Corporation. Refer to the *Terms of Use* section on [ni.com/legal](http://ni.com/legal) for more information about National Instruments trademarks. Other product and company names mentioned herein are trademarks or trade names of their respective companies. For patents covering National Instruments products, refer to the appropriate location: **Help»Patents** in your software, the `patents.txt` file on your CD, or [ni.com/patents](http://ni.com/patents).