

USER GUIDE AND SPECIFICATIONS

NI CF-6004

This user guide describes how to use the National Instruments CF-6004 data acquisition (DAQ) device and lists specifications.

Introduction

The NI CF-6004 provides connection to four analog input (AI) channels and four digital input/output (DIO) channels, with a type II CompactFlash interface.



Figure 1. NI CF-6004

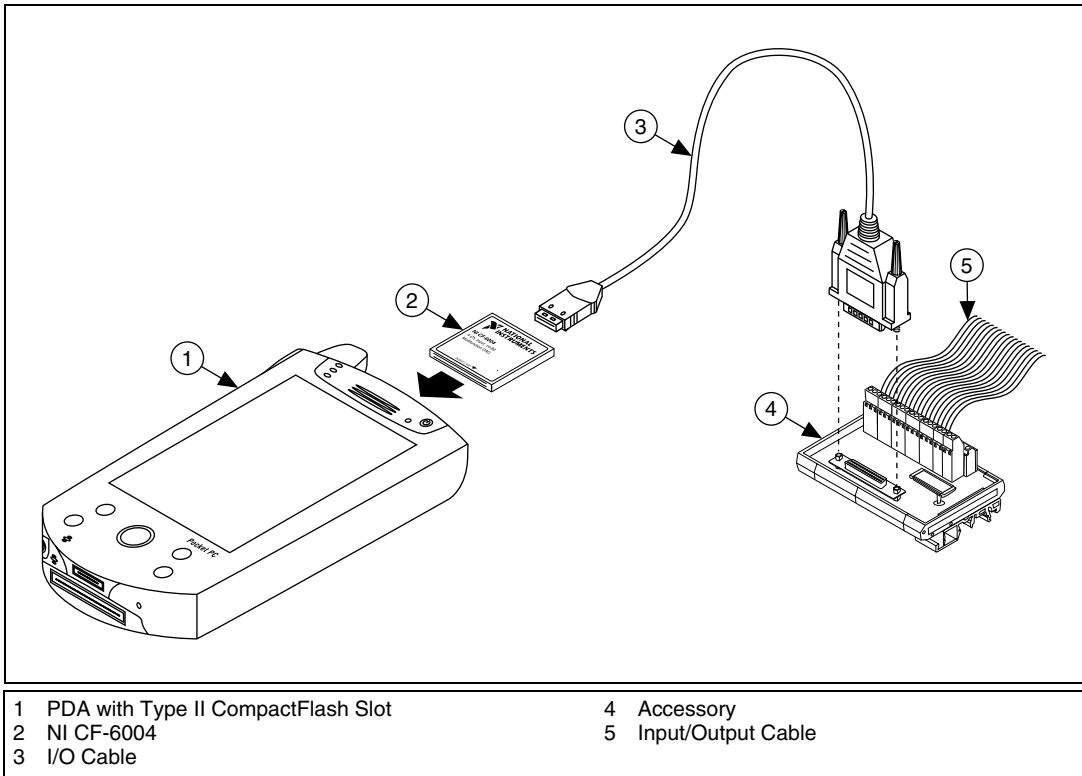

Figure 2. NI CF-6004 Installation

Safety Guidelines



Caution Operate the hardware only as described in these operating instructions.

The following section contains important safety information that you must follow when installing and using the NI CF-6004.

Do not operate the NI CF-6004 in a manner not specified in this document. Misuse of the device can result in a hazard. You can compromise the safety protection built into the device if the device is damaged in any way. If the device is damaged, contact National Instruments for repair.

Do not substitute parts or modify the device except as described in this document. Use the device only with the chassis, modules, accessories, and cables specified in the user guide. You must have all covers and filler panels installed during operation of the device.

Do not operate the device in an explosive atmosphere or where there may be flammable gases or fumes. If you must operate the device in such an environment, it must be in a suitably rated enclosure.

If you need to clean the device, use a dry cloth. Make sure that the device is completely dry and free from contaminants before returning it to service.

Operate the device only at or below Pollution Degree 2. Pollution is foreign matter in a solid, liquid, or gaseous state that can reduce dielectric strength or surface resistivity. The following is a description of pollution degrees:

- Pollution Degree 1 means no pollution or only dry, nonconductive pollution occurs. The pollution has no influence.
- Pollution Degree 2 means that only nonconductive pollution occurs in most cases. Occasionally, however, a temporary conductivity caused by condensation must be expected.
- Pollution Degree 3 means that conductive pollution occurs, or dry, nonconductive pollution occurs that becomes conductive due to condensation.

You must insulate signal connections for the maximum voltage for which the device is rated. Do not exceed the maximum ratings for the device. Do not install wiring while the device is live with electrical signals. Do not remove or add connector blocks when power is connected to the system. Avoid contact between your body and the connector block signal when hot swapping modules. Remove power from signal lines before connecting them to or disconnecting them from the device.

Operate the device at or below the Measurement Category I¹. Measurement circuits are subjected to working voltages² and transient stresses (overvoltage) from the circuit to which they are connected during measurement or test. Measurement categories establish standard impulse withstand voltage levels that commonly occur in electrical distribution systems. The following is a description of measurement categories:

- Measurement Category I is for measurements performed on circuits not directly connected to the electrical distribution system referred to as MAINS³ voltage. This category is for measurements of voltages from specially protected secondary circuits. Such voltage measurements include signal levels, special equipment, limited-energy parts of equipment, circuits powered by regulated low-voltage sources, and electronics.

¹ Measurement Category as defined in electrical safety standard IEC 61010-1. Measurement Category is also referred to as Installation Category.

² Working Voltage is the highest rms value of an AC or DC voltage that can occur across any particular insulation.

³ MAINS is defined as a hazardous live electrical supply system that powers equipment. Suitably rated measuring circuits may be connected to the MAINS for measuring purposes.

- Measurement Category II is for measurements performed on circuits directly connected to the electrical distribution system. This category refers to local-level electrical distribution, such as that provided by a standard wall outlet (for example, 115 V for U.S. or 230 V for Europe). Examples of Measurement Category II are measurements performed on household appliances, portable tools, and similar devices.
- Measurement Category III is for measurements performed in the building installation at the distribution level. This category refers to measurements on hard-wired equipment such as equipment in fixed installations, distribution boards, and circuit breakers. Other examples are wiring, including cables, bus-bars, junction boxes, switches, socket-outlets in the fixed installation, and stationary motors with permanent connections to fixed installations.
- Measurement Category IV is for measurements performed at the primary electrical supply installation (<1,000 V). Examples include electricity meters and measurements on primary overcurrent protection devices and on ripple control units.

Related Documentation

The following section lists documentation that is available for use with the NI CF-6004.

NI-DAQmx Base (Linux/Mac OS X/LabVIEW PDA 8.x)

The *NI-DAQmx Base Getting Started Guide* describes how to install your NI-DAQmx Base software, your NI-DAQmx Base-supported DAQ device, and how to confirm that your device is operating properly. In Windows, select **Start»All Programs»National Instruments»NI-DAQmx Base»Documentation»Getting Started Guide**.

Getting Started with NI-DAQmx Base for Linux and Mac Users describes how to install your NI-DAQmx Base software, your NI-DAQmx Base-supported DAQ device, and how to confirm that your device is operating properly on your Mac/Linux machine.

The *NI-DAQmx Base Readme* lists which devices are supported by this version of NI-DAQmx Base. In Windows, select **Start»All Programs»National Instruments»NI-DAQmx Base»DAQmx Base Readme**.

The *NI-DAQmx Base VI Reference Help* contains VI reference and general information about measurement concepts. In LabVIEW, select **Help»NI-DAQmx Base VI Reference Help**.

The *NI-DAQmx Base C Reference Help* contains C reference and general information about measurement concepts. In Windows, select **Start»All Programs»National Instruments»NI-DAQmx Base»Documentation»C Function Reference Help**.



Note All NI-DAQmx Base documentation for Linux is installed at `/usr/local/natinst/nidaqmxbase/documentation`.



Note All NI-DAQmx Base documentation for Mac OS X is installed at `/Applications/National Instruments/NI-DAQmx Base/documentation`.

Example Programs

The NI-DAQmx Base software ships with example programs you can use to get started programming with the NI CF-6004. Refer to the *NI-DAQmx Base Getting Started Guide* that shipped with your device, and is also accessible from **Start»All Programs»National Instruments»NI-DAQmx Base»Documentation**, for more information.



Note For information about non-Windows operating system support, refer to `ni.com/info` and enter `BaseGSGML`.

Training Courses

If you need more help getting started developing an application with NI products, NI offers training courses. To enroll in a course or obtain a detailed course outline, refer to `ni.com/training`.

Technical Support on the Web

For additional support, refer to `ni.com/support` or `zone.ni.com`.

Installing the Software

Software support for the NI CF-6004 for Windows Vista/XP/2000 is provided by NI-DAQmx Base.



Note For non-Windows operating support, refer to `ni.com/info` and enter `BaseGSGML`.

Block Diagram

The following block diagram shows key functional components of the NI CF-6004.

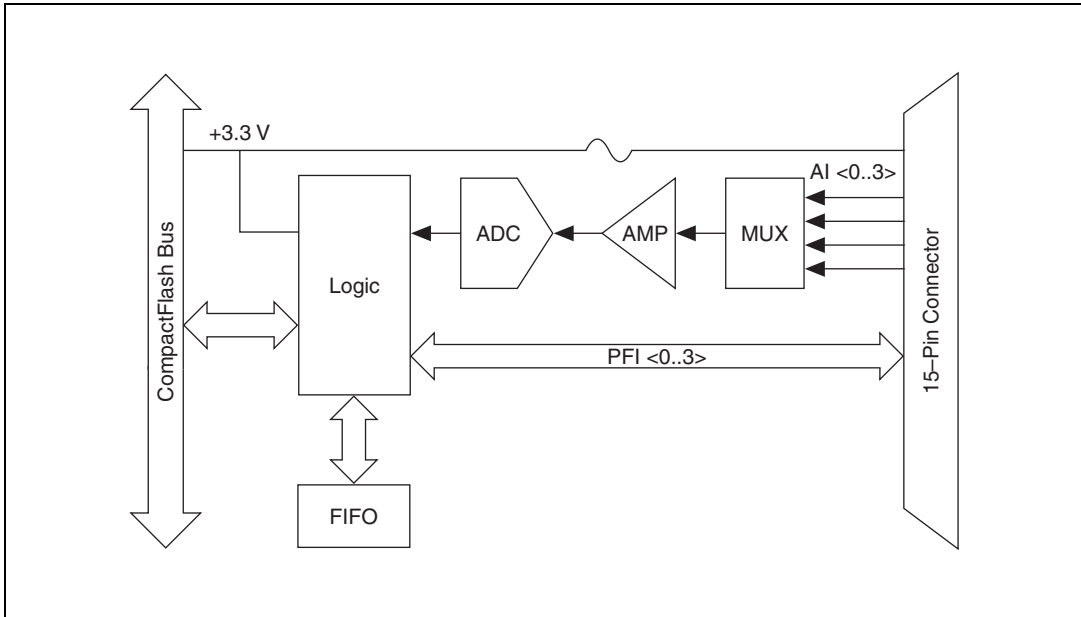

Figure 3. NI CF-6004 Device Block Diagram

I/O Connector

The NI CF-6004 is available with either a SH-15-15 DB-15 or a SH-15-15-B bare-wire adapter cable. Additional accessories are available for custom cable and DIN-rail applications. For more information, visit ni.com.

Table 1 lists the terminal assignments for the SH-15-15 DB-15 adapter cable.

Table 1. Terminal Assignments

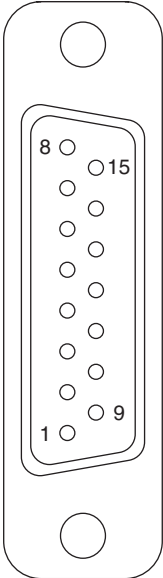
Module	Terminal	Signal	Wire Color
	1	AI GND	White or Red
	2	AI 0	White/Black
	3	AI 1	Red/Black
	4	AI 2	Yellow/Black
	5	AI 3	Green/Black
	6	RSRVD	Green or Blue
	7	RSRVD	Blue/Black
	8	+3.3 V	Brown/White
	9	NC	—
	10	D GND	Orange or Gray
	11	PFI 0	Orange/Black
	12	PFI 1	Gray/Black
	13	PFI 2	Purple/White
	14	PFI 3	Pink/Black
	15	D GND	Purple or Pink

Signal Descriptions

Table 2 describes the signals available on the I/O connectors.

Table 2. Signal Descriptions

Signal Name	Reference	Direction	Description
AI GND	—	—	Analog Ground —These terminals are the reference point for single-ended AI measurements. The AI GND and D GND ground references are connected on the device.
AI <0..3>	AI GND	Input	Analog Input Channels 0 to 3 —For single-ended measurements, each signal is an analog input voltage channel.
+3.3 V	D GND	Output	+3.3 V Power Source —Provides +3.3 V power up to 10 mA.
D GND	—	—	Digital Ground —D GND supplies the reference for PFI <0..3> and +3.3 V. The AI GND and D GND ground references are connected on the device.
PFI <0..3>	D GND	Input or Output	Programmable Function I/O or Digital I/O —Each of these terminals are configurable as a PFI terminal or a digital I/O terminal. You can individually configure each digital I/O signal as an input or output. You can configure any of the terminals as a PFI input for a digital AI trigger.

Analog Input

You can connect analog input signals to the NI CF-6004 through the I/O connector. Refer to Table 2 for more information about connecting analog input signals.

Analog Input Circuitry

Figure 4 illustrates the analog input circuitry of the NI CF-6004.

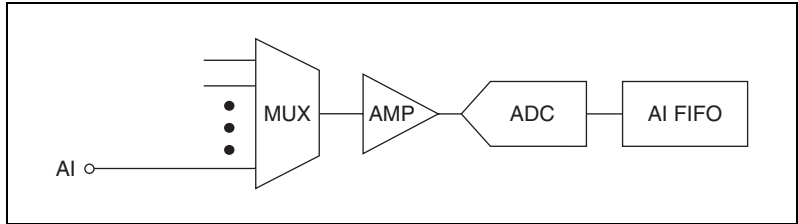

Figure 4. Analog Input Circuitry

MUX

The NI CF-6004 has one analog-to-digital converter (ADC). The multiplexer (MUX) routes one AI channel at a time to the ADC.

AMP

The amplifier provides an effective input gain of 1.

A/D Converter

The analog-to-digital converter (ADC) digitizes the AI signal by converting the analog voltage into a digital code.

AI FIFO

The NI CF-6004 can perform both single and multiple A/D conversions of a fixed or infinite number of samples. A first-in-first-out (FIFO) buffer holds data during AI acquisitions to ensure that no data is lost.

Connecting Single-Ended Voltage Signals

To connect single-ended voltage signals to the NI CF-6004, connect the positive voltage signal to the desired AI terminal, and the ground signal to an AI GND terminal.

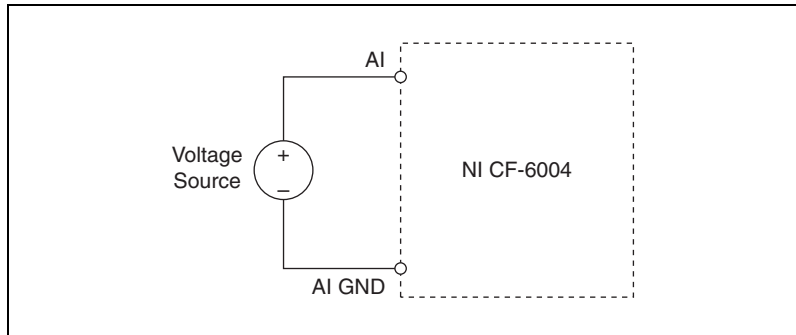

Figure 5. Connecting a Single-Ended Voltage Signal

Digital Trigger

When an AI task is defined, you can configure any one of the PFI inputs as a digital trigger input. When the digital trigger is enabled, the AI task waits for either a rising or falling edge on any PFI before starting the acquisition. To use AI Start Trigger with a digital source, specify the desired PFI input as the source and select the desired edge.

Digital I/O

The NI CF-6004 has four digital lines, PFI <0..3>, which comprise the DIO port. GND is the ground-reference signal for the DIO port. You can individually program all lines as inputs or outputs.

Digital I/O Circuitry

Figure 6 shows PFI <0..3> configured for digital input and digital output. Digital input applications include receiving TTL signals and sensing external device states, such as the state of the switch shown in Figure 6. Digital output applications also include sending TTL signals and driving external devices.

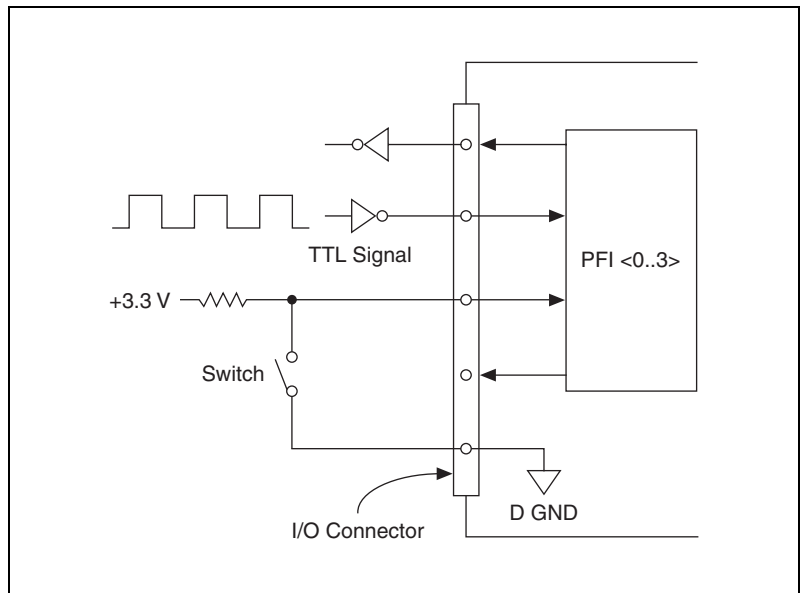

Figure 6. Example of Connecting a Load



Caution Exceeding the maximum input voltage ratings, which are listed in the [Specifications](#) section, can damage the DAQ device and the computer. National Instruments is not liable for any damage resulting from such signal connections.

Source/Sink Info

The NI CF-6004 DIO ports are push-pull, allowing 3.3 V operation.

I/O Protection

To protect the NI CF-6004 against overvoltage, undervoltage, and overcurrent conditions as well as ESD events, use the following guidelines:

- If you configure a DIO line as an output, do not connect it to any external signal source, ground signal, or power supply.
- If you configure a DIO line as an output, understand the current requirements of the load connected to these signals. Do not exceed the specified current output limits of the DAQ device.
- If you configure a DIO line as an input, do not drive the line with voltages outside of its normal operating range. The DIO lines have a smaller operating range than the AI signals.
- Treat the DAQ device as you would treat any static-sensitive device. Always properly ground yourself and the equipment when handling or connecting to the DAQ device.

Power-On States

At system startup and reset, the hardware sets all DIO lines to high-impedance inputs. The DAQ device does not drive the signal high or low.

Static DIO

Each of the NI CF-6004 DIO lines can be used as a static DI or DO line. You can use static DIO lines to monitor or control digital signals. All samples of static DI lines and updates of DO lines are software-timed.

+3.3 V Power Source

The NI CF-6004 supplies a 3.3 V, 10 mA output. This source can be used to power external components.

Specifications

The following specifications are typical at 25 °C, unless otherwise noted.

Analog Input

Number of channels	4 single-ended
ADC type	Successive approximation
ADC resolution	14 bits
DNL	No missing codes
INL	±1 LSB
Sample rate (might be system-dependent)	
Single-channel, finite acquisition	
Up to 8 kS total, raw or calibrated	200 kS/s
Up to 1 MS, raw data	200 kS/s
Multi-channel, finite acquisition	
Up to 8 kS total, raw or calibrated	132 kS/s, aggregate
Up to 1 MS total, raw data	132 kS/s, aggregate
Continuous acquisition, single- and multi-channel	
Calibrated data, monitoring	18 kS/s, typical
Calibrated data, graphing	1 kS/s, typical
Minimum hardware-timed	195 S/s
Timing accuracy	50 ppm
Timing resolution	78.125 ns
Settling time	20 ppm at 7.6 μs, 0.1 Ω source impedance
Input coupling	DC
Input range	±5 V
Maximum working voltage	±5 V
Input impedance	100 MΩ, in parallel with 20 pF
Input bias current	75 pA

Crosstalk (at 1 kHz)	
Adjacent channels.....	-104 dB typical
Non-adjacent channels.....	-104 dB typical
Small signal bandwidth -3 dB.....	497 kHz
System noise	0.75 LSB _{rms}
Input FIFO size	8,192 samples
Data transfers	Programmed I/O
Overvoltage protection	±15 V
Input current during overvoltage condition	15.3 mA maximum
Accuracy over the operating range	±3.1 mV typical, ±21 mV maximum

Calibration

Recommended warm-up time.....	15 minutes
Calibration interval.....	1 year

Digital I/O

Number of channels.....	4 lines, PFI <0..3>
Direction control.....	Each channel individually programmable as input or output
Output driver type.....	Push-pull
Compatibility	3.3 V LVCMOS and LVTTL
Power-on state	Input (high-impedance)
Data transfers	Programmed I/O
Absolute maximum voltage range	-0.5 V to 4 V

Digital logic levels

Level	Min	Max	Units
Input low voltage	-0.3	0.8	V
Input high voltage	2	3.9	V
Input leakage current	-1	1	μ A
Output low voltage (I = 2 mA)	—	0.8	V
Output high voltage (I = 2 mA)	2.5	—	V
Input current (0 < Vin < 3.3 V)	-1	1	μ A

External Voltage References

+3.3 V output (10 mA maximum) 3.3 V typical, 2.97 V minimum

Power Requirements

+3.3 V from PDA host

Idle maximum 2 mA

Typical (continuous acquisition) 50 mA

Maximum (all outputs loaded)..... 68 mA

Physical Characteristics

Dimensions Type II CompactFlash Card

I/O connectors 15-pin

Weight 9 g (0.3 oz)

Environmental

The NI CF-6004 device is intended for indoor use only.

Operating temperature

(IEC 60068-2-1 and IEC 60068-2-2) 0 to 40 °C

Operating humidity

(IEC 60068-2-56) 10 to 90% RH, noncondensing

Storage temperature

(IEC 60068-2-1 and IEC 60068-2-2) -20 to 70 °C

Storage humidity

(IEC 60068-2-56) 5 to 90% RH, noncondensing

Maximum altitude.....2,000 m (at 25 °C ambient temperature)

Pollution Degree (IEC 60664).....2

Safety

If you need to clean the module, wipe it with a dry towel.

Safety Voltages

Connect only voltages that are within the absolute maximum limits of the connection point. Refer to the *External Voltage References* and *Power Requirements* sections for the appropriate limits.

Safety Standards

The NI CF-6004 is designed to meet the requirements of the following standards of safety for electrical equipment for measurement, control, and laboratory use:

- IEC 61010-1, EN 61010-1
- UL 61010-1, CSA 61010-1



Note For UL and other safety certifications, refer to the product label, or visit ni.com/certification, search by model number or product line, and click the appropriate link in the Certification column.

Hazardous Locations

The NI CF-6004 is not certified for use in hazardous locations.

Electromagnetic Compatibility

This product meets the essential requirements of the following standards of EMC for electrical equipment for measurement, control, and laboratory use:

- EN 61326 EMC requirements; Minimum Immunity
- EN 55011 Emissions; Group 1, Class A
- CE, C-Tick, ICES, and FCC Part 15 Emissions; Class A



Note For EMC compliance, operate this device with shielded cables.

CE Compliance

This product meets the essential requirements of applicable European Directives, as amended for CE marking, as follows:

- 2006/95/EC; Low-Voltage Directive (safety)
- 2004/108/EC; Electromagnetic Compatibility Directive (EMC)



Note Refer to the Declaration of Conformity (DoC) for this product for any additional regulatory compliance information. To obtain the DoC for this product, visit ni.com/certification, search by model number or product line, and click the appropriate link in the Certification column.

Environmental Management

National Instruments is committed to designing and manufacturing products in an environmentally responsible manner. NI recognizes that eliminating certain hazardous substances from our products is beneficial not only to the environment but also to NI customers.

For additional environmental information, refer to the *NI and the Environment* Web page at ni.com/environment. This page contains the environmental regulations and directives with which NI complies, as well as other environmental information not included in this document.

Waste Electrical and Electronic Equipment (WEEE)



EU Customers At the end of their life cycle, all products *must* be sent to a WEEE recycling center. For more information about WEEE recycling centers and National Instruments WEEE initiatives, visit ni.com/environment/weee.htm.

电子信息产品污染控制管理办法（中国 RoHS）



中国客户 National Instruments 符合中国电子信息产品中限制使用某些有害物质指令 (RoHS)。关于 National Instruments 中国 RoHS 合规性信息, 请登录 ni.com/environment/rohs_china。(For information about China RoHS compliance, go to ni.com/environment/rohs_china.)

Where to Go for Support

The National Instruments Web site is your complete resource for technical support. At ni.com/support you have access to everything from troubleshooting and application development self-help resources to email and phone assistance from NI Application Engineers.

National Instruments corporate headquarters is located at 11500 North Mopac Expressway, Austin, Texas, 78759-3504. National Instruments also has offices located around the world to help address your support needs. For telephone support in the United States, create your service request at ni.com/support and follow the calling instructions or dial 512 795 8248. For telephone support outside the United States, contact your local branch office:

Australia 1800 300 800, Austria 43 662 457990-0,
Belgium 32 (0) 2 757 0020, Brazil 55 11 3262 3599,
Canada 800 433 3488, China 86 21 5050 9800,
Czech Republic 420 224 235 774, Denmark 45 45 76 26 00,
Finland 358 (0) 9 725 72511, France 01 57 66 24 24,
Germany 49 89 7413130, India 91 80 41190000, Israel 972 3 6393737,
Italy 39 02 41309277, Japan 0120-527196, Korea 82 02 3451 3400,
Lebanon 961 (0) 1 33 28 28, Malaysia 1800 887710,
Mexico 01 800 010 0793, Netherlands 31 (0) 348 433 466,
New Zealand 0800 553 322, Norway 47 (0) 66 90 76 60,
Poland 48 22 3390150, Portugal 351 210 311 210, Russia 7 495 783 6851,
Singapore 1800 226 5886, Slovenia 386 3 425 42 00,
South Africa 27 0 11 805 8197, Spain 34 91 640 0085,
Sweden 46 (0) 8 587 895 00, Switzerland 41 56 2005151,
Taiwan 886 02 2377 2222, Thailand 662 278 6777,
Turkey 90 212 279 3031, United Kingdom 44 (0) 1635 523545

National Instruments, NI, ni.com, and LabVIEW are trademarks of National Instruments Corporation. Refer to the *Terms of Use* section on ni.com/legal for more information about National Instruments trademarks. Other product and company names mentioned herein are trademarks or trade names of their respective companies. For patents covering National Instruments products, refer to the appropriate location: **Help»Patents** in your software, the `patents.txt` file on your CD, or ni.com/patents.