

QUICK START GUIDE

FieldPoint™ cFP-2120

What You Need to Get Set Up

- cFP-2120 LabVIEW RT controller
- Mounting hardware (DIN rail, panel-mount, or rack-mount accessory)
- I/O module(s)
- cFP-BP-x backplane, connector blocks, cables
- 11–30 VDC power supply
- Accessories: Ethernet cable, number 2 Phillips screwdriver
- PC running Windows
- FieldPoint software 4.1.1 or later
- LabVIEW Real-Time Module

1

Mount the Compact FieldPoint Backplane

You can mount the cFP-BP-x backplane on a 35 mm DIN rail, on a panel, or in a standard 19 in. rack. Before using any of these mounting methods, record the serial number from the back of the backplane.

Each set of mounting instructions in this document includes an instruction to connect the protective earth (PE) ground terminal on the cFP-BP-x backplane to the system safety ground. The backplane PE ground terminal has the following symbol stamped beside it: Ⓧ. Connect the backplane PE ground terminal to the system safety ground using 14 AWG (1.6 mm) wire with a ring lug. Use the 5/16 in. panhead screw shipped with the backplane to secure the ring lug to the backplane PE ground terminal.



Caution Keep in mind these requirements for space and cabling clearance:

- Allow at least 51 mm (2 in.) all around the backplane for air circulation.
- Allow 38 mm (1.5 in.) below and 51 mm (2 in.) above the controller for cabling clearance.

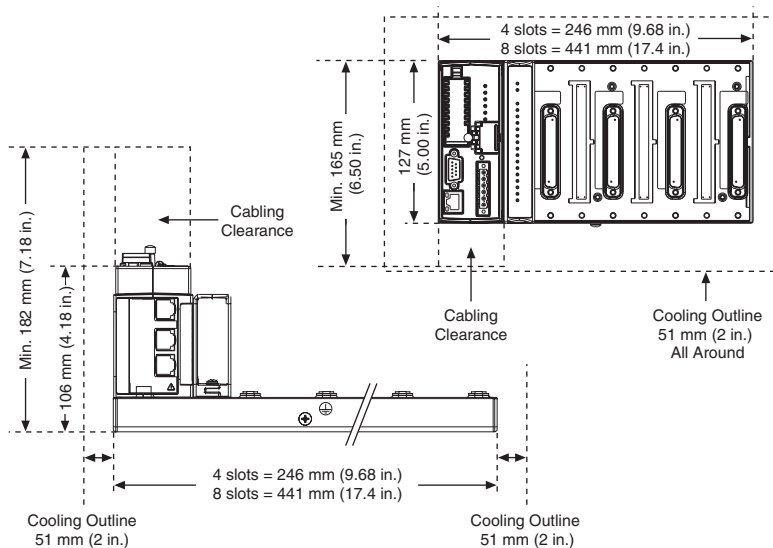



Caution If you are using UL Recognized I/O modules with the Compact FieldPoint system, you must install the entire system in a suitably rated, UL Listed NEMA or IP enclosure.

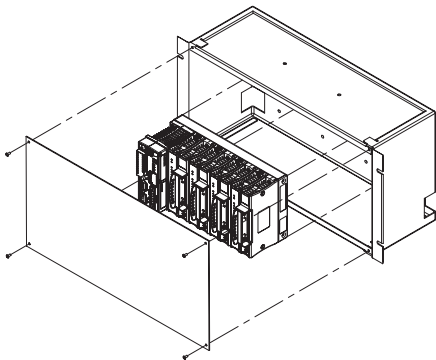

Caution NI recommends that you use one of the mounting systems described in this document. If you decide to use a custom mounting solution, make sure that the screws you use are short enough to fit in the holes in the backplane. The screw holes are 5 mm (0.2 in.) deep.

Mounting the Backplane on a Panel

- A. Fasten the panel-mount plates to the back of the cFP-BP-x using a number 2 Phillips screwdriver and the 8-32 \times 5/16 in. countersink screws shipped with the kit.

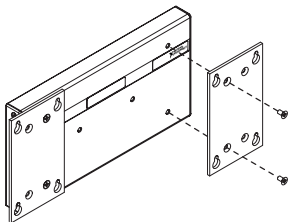

Caution Do not use screws longer than 5/16 in. to fasten the panel-mount plates to the backplane.

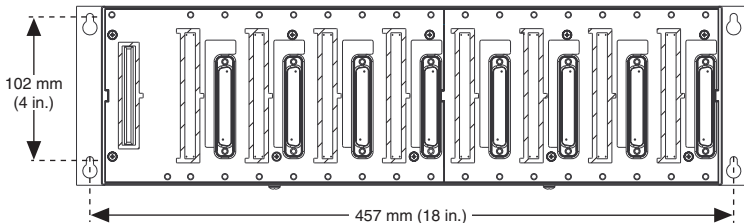

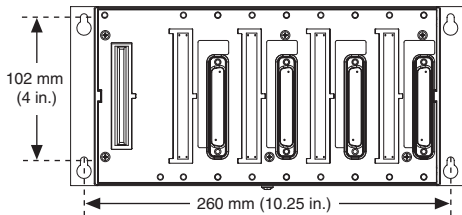
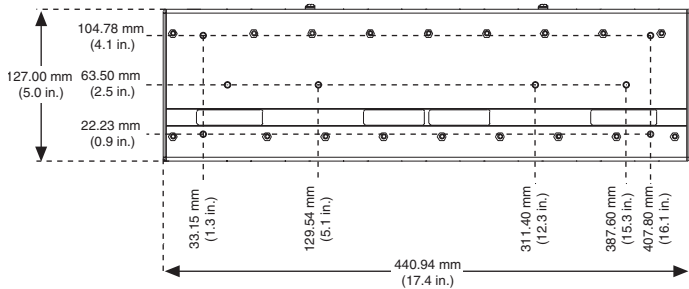

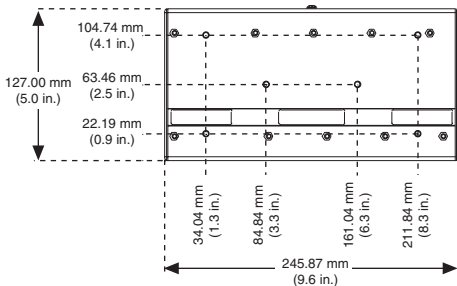

- B. Bolt or screw the panel-mount accessory to a panel.
- C. Connect the PE ground terminal on the cFP-BP-x to safety ground.



Caution Disconnect power before removing the backplane from the panel.

Mounting the Backplane on a DIN Rail

NI recommends DIN rail mounting for the cFP-BP-4 only. Use panel mounting or rack mounting for the cFP-BP-8. The DIN rail mounting kit is NI part number 778614-01

- A. Fasten the DIN rail clip to the cFP-BP-4 using a number 2 Phillips screwdriver and the 8-32 \times 5/16 in. countersink screws shipped with the clip.

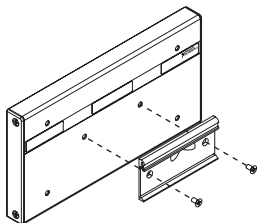

Caution Do not use screws longer than 5/16 in. to fasten the DIN rail clip to the backplane.

- B. Insert one edge of the DIN rail into the deeper opening of the DIN rail clip.
- C. Press down firmly on the backplane to compress the spring until the clip locks in place on the DIN rail.

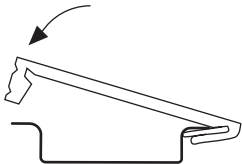

- D. Connect the PE ground terminal on the cFP-BP-4 to safety ground.



Caution Disconnect power before removing the backplane from the DIN rail.

Mounting the Backplane in a Standard 19-in. Rack

- A. Fasten the rack-mount bracket to the back of the cFP-BP-x using the captive screws on the bracket.

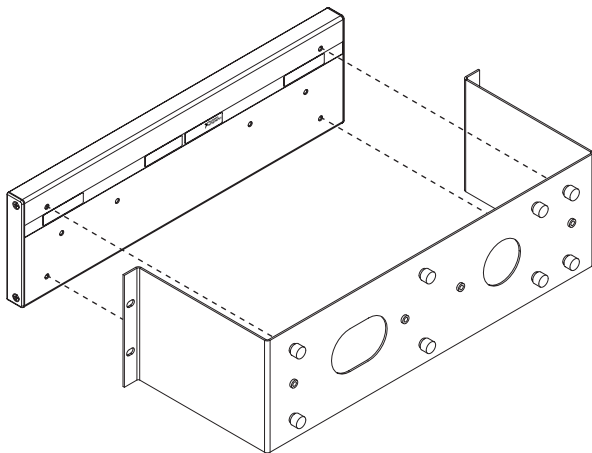

- B. Bolt the rack-mount accessory to a standard 19-in. rack.
- C. Connect the PE ground terminal on the cFP-BP-x to safety ground.

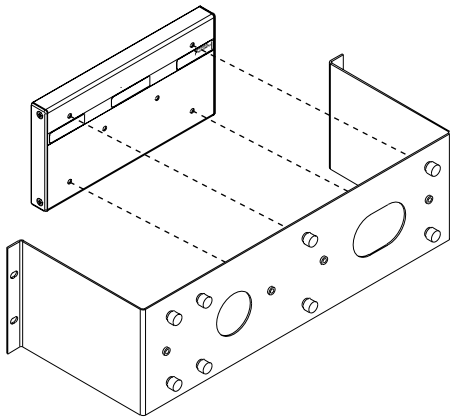

Caution Disconnect power before removing the backplane from the DIN rail.

2**Install the cFP-2120 Controller on the Backplane**

- A. Make sure that no power is connected to the controller.
- B. Make sure that the cFP-2120 controller is right side up with the NI logo at the top, and align the captive screws on the controller with the holes on the backplane.
- C. Seat the card edge at the back of the controller in the card-edge connector on the backplane.
- D. Press the controller firmly to seat it on the backplane.
- E. Using a number 2 Phillips screwdriver with a shank of at least 64 mm (2.5 in.) length, tighten the captive screws to 1.1 N · m (10 lb · in.) of torque.

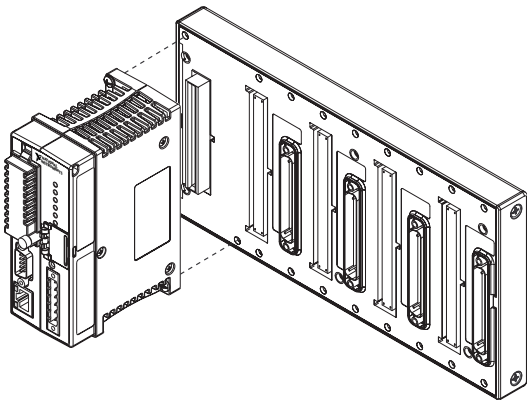

3**Install I/O Modules on the Backplane**

- A. Align the captive screws on the I/O module with the holes on the backplane.
- B. Press firmly to seat the I/O module on the backplane.
- C. Using a number 2 Phillips screwdriver with a shank of at least 64 mm (2.5 in.) length, tighten the captive screws to 1.1 N · m (10 lb · in.) of torque.
- D. Repeat this procedure to install additional I/O modules on the backplane.

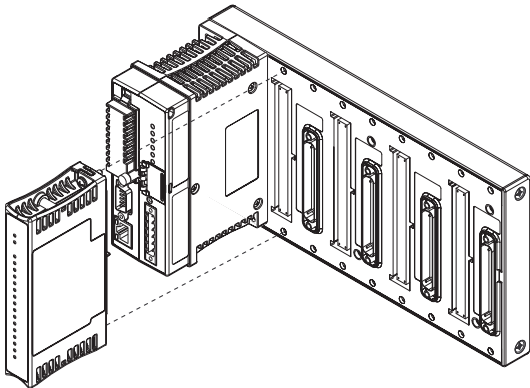

4

Install Connector Blocks on the Backplane

In order to connect I/O modules to input signals or to external loads, you need to install a cFP-CB-x connector block or other connectivity accessory for each I/O module on the backplane. Use the connector socket to the right of each I/O module socket.



Caution Do not insert or remove connector blocks or other connectivity accessories while power is applied to them.

- A. Wire field devices as described in the I/O module and connector block operating instructions.



Caution Hazardous voltage wiring should be performed by qualified personnel and in accordance with local electrical standards.

- B. Align the captive screws on the connector block with the holes on the backplane.
- C. Press firmly to seat the connector block on the backplane.
- D. Using a number 2 Phillips screwdriver with a shank of at least 64 mm (2.5 in.) length, tighten the captive screws to 1.1 N · m (10 lb · in.) of torque.
- E. Repeat this procedure to install additional connector blocks on the backplane.

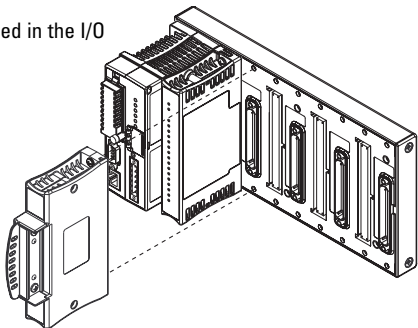

5**Connect the cFP-2120 to Your Network**

Connect the cFP-2120 controller to an Ethernet network using the RJ-45 Ethernet port on the controller. Use a standard Category 5 Ethernet cable to connect the cFP-2120 to an Ethernet hub, or use an Ethernet crossover cable to connect the controller directly to a computer.



Caution To prevent data loss and to maintain the integrity of your Ethernet installation, do not use a cable longer than 100 m. If you are using a 100 Mbps Ethernet, National Instruments recommends using a Category 5 shielded twisted-pair Ethernet cable.

If the host PC is already configured on a network, you must configure the cFP-2120 on the same network. If neither is connected to a network, you can connect the two directly using a crossover cable.

In order for you to configure the cFP-2120, it must reside on the same subnet as the host PC.

6

Wire Power to the Compact FieldPoint System

Each cFP-2120 on your network requires an 11–30 VDC power supply.

- A. Connect the positive lead of the primary power supply to one of the V1 terminals and the negative lead to one of the C terminals.
- B. If you are using a backup power supply, connect the positive lead to V2 and the negative lead to one of the C terminals. The cFP-2120 uses the power supply with the higher voltage level. V2 is isolated from the other V terminals.
- C. Refer to the operating instructions for the power requirements of each I/O module.
- D. Use a separate power supply for each module that needs external power.

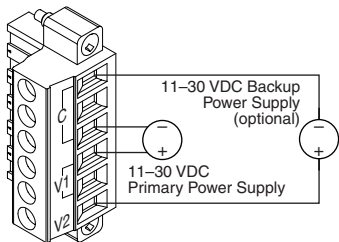

Caution Cascading power defeats isolation between the cascaded modules.

7

Power Up the cFP-2120

Check the DIP switches on the controller, making sure that the RESET IP switch is in the OFF position. Plug in each power supply to the Compact FieldPoint system. The cFP-2120 runs a power-on self test (POST) that takes several seconds. You should see the POWER and STATUS LEDs come on. After about three seconds, the STATUS LED begins flashing steadily. The cFP-2120 is ready to be configured.

If you have already assigned an IP address to the cFP-2120, the STATUS LED turns off. The total boot time for a configured system is 10–15 seconds.

If the STATUS LED does not light up as described here, refer to the *cFP-21xx and cFP-BP-x User Manual* at `d:\docs\Network Modules`, where `d` is the letter of your CD-ROM drive.

DIP Switches	Functions
1, 2	Disabled
3, 4	User-configurable
5	CONSOLE OUT
6	DISABLE VI
7	SAFE MODE
8	RESET IP

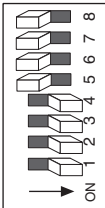

8

Install Software on the Host PC

- A. Install the software packages you plan to use, such as LabVIEW, the LabVIEW Real-Time Module, Measurement Studio, VI Logger, or LabWindows™/CVI™, before you install the FieldPoint software. The FieldPoint software installation installs the LabVIEW VIs and examples and the LabWindows/CVI instrument driver only if it finds the corresponding development software installed.
- B. Close all other applications.
- C. Insert the National Instruments FieldPoint Software CD into the CD-ROM drive on your computer.
- D. Follow the onscreen instructions to complete the installation.



Note If the setup does not launch automatically, select **Start»Run** from Windows, enter `d:\setup`, where `d` is the letter of your CD-ROM drive, and select **OK**.

9

Configure the cFP-2120

Launch Measurement & Automation Explorer (MAX) to configure the cFP-2120. For information about configuring the cFP-2120 in software, refer to the *Measurement & Automation Explorer Help for FieldPoint (Start»Programs»National Instruments»FieldPoint»FieldPoint Help)*.

For information about using the cFP-2120 with the LabVIEW Real-Time Module, refer to the *cFP-21xx and cFP-BP-x User Manual*.

Specifications

Network

Network interface	10BaseT and 100BaseTX Ethernet
Compatibility	IEEE802.3
Communication rates	10 Mbps, 100 Mbps, auto-negotiated
Maximum cabling distance	100 m/segment
Maximum power to connected I/O modules	9 W
Maximum number of banks	Determined by network topology

Memory

128 MB nonvolatile; 128 MB DRAM	
Memory lifetime (nonvolatile)	300,000 writes per sector

For information about the memory used by the LabVIEW Real-Time Module and the operating system, go to ni.com/info and enter `rdfpec`.

Serial Ports

Three RS-232 (DTE) serial ports	
Baud rate	110 to 115,200 bps
Data bits	5, 6, 7, 8
Stop bits	1, 1.5, 2
Parity	Odd, Even, Mark, Space
Flow control	RTS/CTS, XON/XOFF, DTR/DSR

One RS-485 (DTE) serial port

Baud rate	110 to 115,200 bps
Data bits	5, 6, 7, 8
Stop bits	1, 1.5, 2
Parity	Odd, Even, Mark, Space
Flow control	XON/XOFF
Wire mode	4-wire
Maximum continuous isolation voltage	100 V _{rms}
Dielectric withstand	740 V _{rms} , 1 minute

Power Requirement

Power supply range 11–30 VDC

Recommended power supply

cFP-BP-4 system	15 W
cFP-BP-8 system	20 W

Power consumption 6.1 W + 1.1(I/O module power requirements)

Physical Characteristics

Screw-terminal wiring	16–26 AWG copper conductor wire with 7 mm (0.28 in.) of insulation stripped from the end
Torque for screw terminals	0.5–0.6 N · m (4.4–5.3 lb · in.)
Weight	278 g (9.8 oz)

Environmental

FieldPoint modules are intended for indoor use only. For outdoor use, they must be installed in a suitable sealed enclosure.

Operating temperature	-40 to 70 °C
Storage temperature	-55 to 85 °C
Humidity	10 to 90% RH, noncondensing
Maximum altitude	2,000 m; at higher altitudes the isolation voltage ratings must be lowered
Pollution Degree	2

Shock and Vibration

Operating vibration

Random (IEC 60068-2-64) 10–500 Hz, 5 g_{rms}

Sinusoidal (IEC 60068-2-6) 10–500 Hz, 5 g

Operating shock

(IEC 60068-2-27) 50 g, 3 ms half sine, 18 shocks at 6 orientations;
30 g, 11 ms half sine, 18 shocks at 6 orientations

Safety

This product is designed to meet the requirements of the following standards of safety for electrical equipment for measurement, control, and laboratory use:

- IEC 61010-1, EN 61010-1
- UL 61010-1
- CAN/CSA-C22.2 No. 61010-1



Note For UL, hazardous location, and other safety certifications, refer to the product label or visit ni.com/certification, search by model number or product line, and click the appropriate link in the Certification column.

Electromagnetic Compatibility

Emissions	EN 55011 Class A at 10 m FCC Part 15A above 1 GHz
Immunity	EN 61326:1997 + A2:2002, Table 1
CE, C-Tick, and FCC Part 15 (Class A) Compliant	



Note For EMC compliance, operate this device with shielded cabling.

CE Compliance

This product meets the essential requirements of applicable European Directives, as amended for CE marking, as follows:

Low-Voltage Directive (safety)	73/23/EEC
Electromagnetic Compatibility Directive (EMC)	89/336/EEC



Note Refer to the Declaration of Conformity (DoC) for this product for any additional regulatory compliance information. To obtain the DoC for this product, visit ni.com/certification, search by model number or product line, and click the appropriate link in the Certification column.

Cabling

The table below shows the standard Ethernet cable wiring connections for both normal and crossover cables.

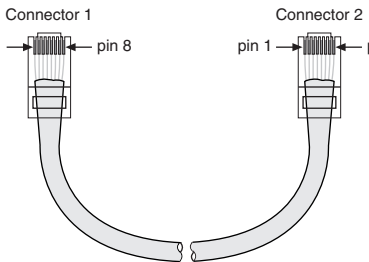

**Ethernet Cable
Connector Pinouts**

Pin	Connector 1	Connector 2 (Normal)	Connector 2 (Crossover)
1	white/orange	white/orange	white/green
2	orange	orange	green
3	white/green	white/green	white/orange
4	blue	blue	blue
5	white/blue	white/blue	white/blue
6	green	green	orange
7	white/brown	white/brown	white/brown
8	brown	brown	brown



The National Instruments Web site is your complete resource for technical support. At ni.com/support you have access to everything from troubleshooting and application development self-help resources to email and phone assistance from NI Application Engineers.

National Instruments corporate headquarters is located at 11500 North Mopac Expressway, Austin, Texas, 78759-3504. National Instruments also has offices located around the world to help address your support needs. For telephone support in the United States, create your service request at ni.com/support and follow the calling instructions or dial 512 795 8248. For telephone support outside the United States, contact your local branch office:

Australia 1800 300 800, Austria 43 0 662 45 79 90 0, Belgium 32 0 2 757 00 20, Brazil 55 11 3262 3599, Canada 800 433 3488, China 86 21 6555 7838, Czech Republic 420 224 235 774, Denmark 45 45 76 26 00, Finland 385 0 9 725 725 11, France 33 0 1 48 14 24 24, Germany 49 0 89 741 31 30, India 91 80 51190000, Israel 972 0 3 6393737, Italy 39 02 413091, Japan 81 3 5472 2970, Korea 82 02 3451 3400, Lebanon 961 0 1 33 28 28, Malaysia 1800 887710, Mexico 01 800 010 0793, Netherlands 31 0 348 433 466, New Zealand 0800 553 322, Norway 47 0 66 90 76 60, Poland 48 22 3390150, Portugal 351 210 311 210, Russia 7 095 783 68 51, Singapore 1800 226 5886, Slovenia 386 3 425 4200, South Africa 27 0 11 805 8197, Spain 34 91 640 0085, Sweden 46 0 8 587 895 00, Switzerland 41 56 200 51 51, Taiwan 886 02 2377 2222, Thailand 662 992 7519, United Kingdom 44 0 1635 523545

National Instruments, NI, ni.com, and LabVIEW are trademarks of National Instruments Corporation. Refer to the Terms of Use section on ni.com/legal for more information about National Instruments trademarks. Other product and company names mentioned herein are trademarks or trade names of their respective companies. For patents covering National Instruments products, refer to the appropriate location: **Help»Patents** in your software, the `patents.txt` file on your CD, or ni.com/patents.

© 2005 National Instruments Corporation. All rights reserved.