

INSTALLATION GUIDE

SCB-100

100-Pin Shielded Desktop Connector Block

This guide describes how to connect and use the NI SCB-100 with 100-pin data acquisition (DAQ) devices. The SCB-100 is a shielded desktop accessory with 100 screw terminals, a cold-junction compensation temperature sensor for use with thermocouples, and a strain-relief bar for securing signal wires or cables. The SCB-100 connects to E Series MIO devices (NI 6025E, NI 6031E, NI 6033E, and NI 6071E), DIO devices (PCI-DIO-96, NI 6508, NI 6509, NI 6511, NI 6512, NI 6513, NI 6514, NI 6515, NI 6527, and NI 6528), TIO Series devices (NI 6624), or other products with a 100-pin 0.050 series shielded D-type I/O connector.



Note To use the SCB-100 with a DIO or TIO Series device, you must change the default switch setting. Refer to the [Using the SCB-100 with DIO/TIO Devices](#) section for more information.

Figure 1 shows the SCB-100 connector block.

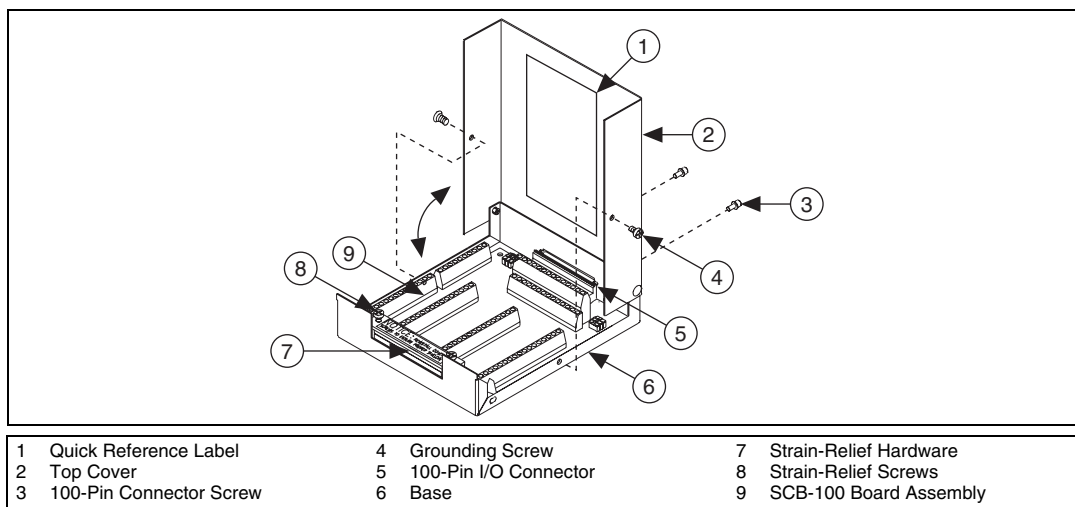

Figure 1. SCB-100 Connector Block

Contents

What You Need to Get Started	2
Attaching the Quick Reference Label	2
Getting Started with the SCB-100	2
Using the SCB-100 with DIO/TIO Devices	4
Using the SCB-100 with MIO Devices	5
Removing the Board	8
Soldering, Desoldering, and Cutting Via Traces on the SCB-100 Board	9
Specifications	9
Where to Go for Support	10

What You Need to Get Started

To set up and use your SCB-100, you need the following:

- SCB-100 100-pin shielded connector block kit, containing the SCB-100, SCB-100 quick reference label, and *SCB-100 Installation Guide*
- 100-pin DAQ device and device documentation
- SH100100 cable (part number 182853-0x) for E Series/MIO devices or SH100-100-F cable (part number 185095-0x) for DIO/TIO Series devices
- Phillips #1 and #2 screwdrivers
- ≤26 AWG wire
- Wire cutters
- Wire insulation strippers
- 1/8 in. flathead screwdriver
- Soldering iron and solder (optional)
- Long nose pliers (optional)
- Resistors and capacitors specific to your application (optional)

Attaching the Quick Reference Label

A quick reference label is included in the SCB-100 100-pin shielded connector block kit to show switch configurations and define screw terminal pinouts for E Series devices. Place the label on the inside of the top cover, as shown in Figure 1.

For a PDF of the E Series quick reference label, refer to the KnowledgeBase document, *Where Can I Find .PDF Copies of the SCB-100 and/or SCB-68 Quick Reference Label Stickers?*. To access this KnowledgeBase, go to ni.com/info and enter the info code `rdwpdf`.

For DIO, TIO Series, or other 100-pin device signal information, refer to your device documentation.

Getting Started with the SCB-100

The following cautions contain important safety information concerning hazardous voltages and connector blocks.



Caution To avoid electrical shock, do *not* remove equipment covers or shields unless you are qualified to do so. If signal wires are connected to the SCB-100, hazardous voltages may exist even when the equipment is turned off. Before removing the cover, disconnect the AC power or any live circuit from the connector block.

The chassis ground terminals on your SCB-100 are for grounding high-impedance sources such as a floating source (1 mA maximum). Do *not* use these terminals as safety earth grounds.

Do *not* connect hazardous voltages ($\geq 42 V_{pk}/60$ VDC). National Instruments is *not* liable for damage or injury resulting from such misuse.

Figure 2 shows the SCB-100 board parts locator diagram.

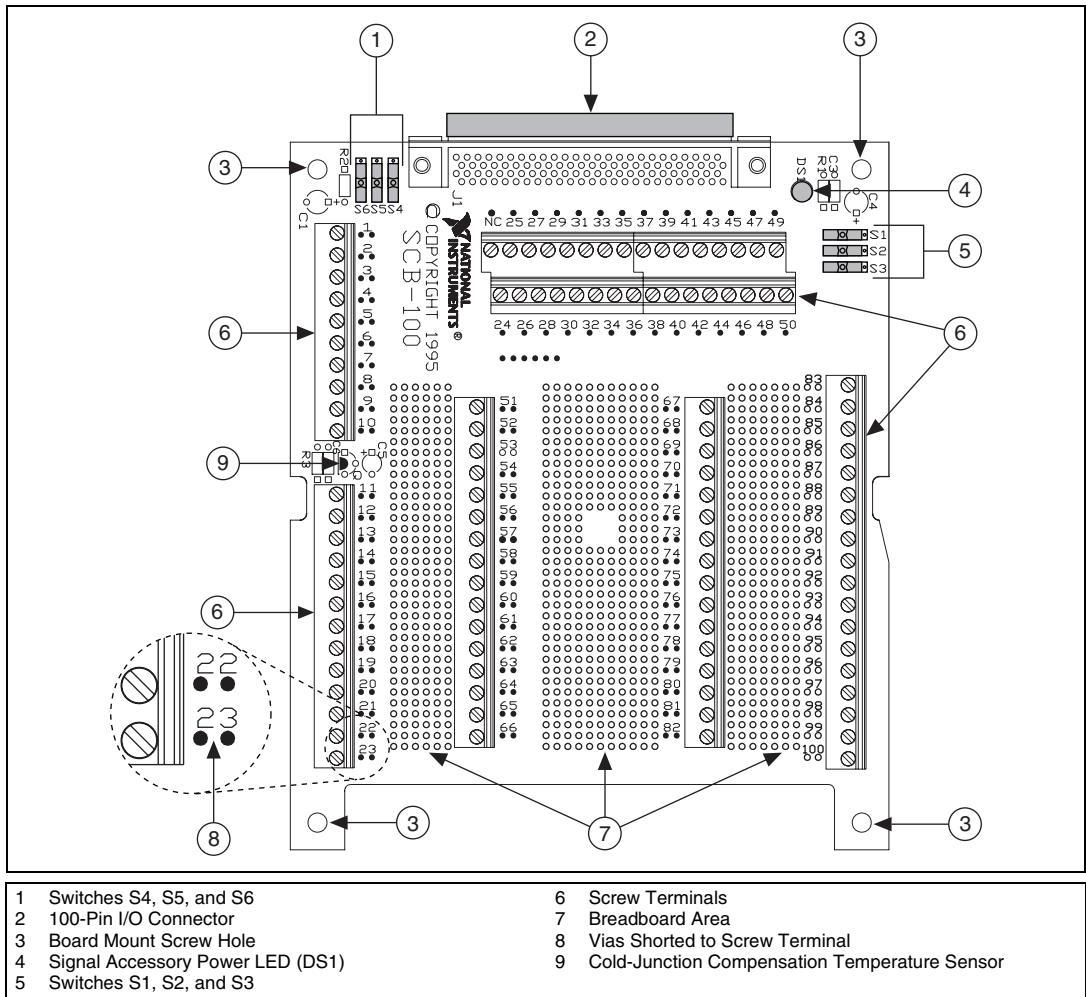

Figure 2. SCB-100 Board Parts Locator Diagram

To get started with the SCB-100, complete the following steps while referring to Figures 1 and 2.

1. Disconnect the 100-pin cable from the SCB-100, if connected.
2. Remove the grounding screws on either side of the top cover with a Phillips #1 screwdriver. Open the top cover.
3. Configure switches for the signal types you are using, as explained in the [Using the SCB-100 with DIO/TIO Devices](#) section or the [Using the SCB-100 with MIO Devices](#) section.
4. Adjust the strain-relief hardware.
 - a. Loosen the strain-relief screws with a Phillips #2 screwdriver and slide the signal wires through the front panel strain-relief opening.
 - b. If you are connecting multiple signals, remove the top strain-relief bar.
5. Add insulation or padding if necessary.

6. Connect the wires to the screw terminals by stripping 1/4 in. of insulation, inserting the wires into the screw terminals, and tightening the screws.
7. Reinstall strain-relief (if removed) and tighten the strain-relief screws.
8. Close the top cover.
9. Reinsert the grounding screws to ensure proper shielding.
10. Connect the SCB-100 to the 100-pin connector.

Using the SCB-100 with DIO/TIO Devices

DIO devices, TIO Series devices, and DAQ devices without analog input functionality *must* use the DIO/passthrough mode. Move the switches to the DIO/passthrough mode switch setting as shown in Table 1.

Table 1. DIO/TIO Series Device Switch Setting

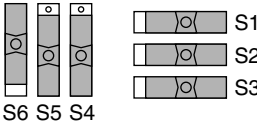
Switch Setting	Description
 <p>S6 S5 S4 S1 S2 S3</p>	<p>DIO/passthrough mode—Move switches S1, S2, S3, S4, S5, and S6 to the positions shown at left. In this mode:</p> <ul style="list-style-type: none"> • All 100 signals from the DAQ device connect directly to screw terminals. • The signal accessory power LED (DS1) does not light in this configuration. <p>Refer to Figure 3 for a detailed diagram.</p>

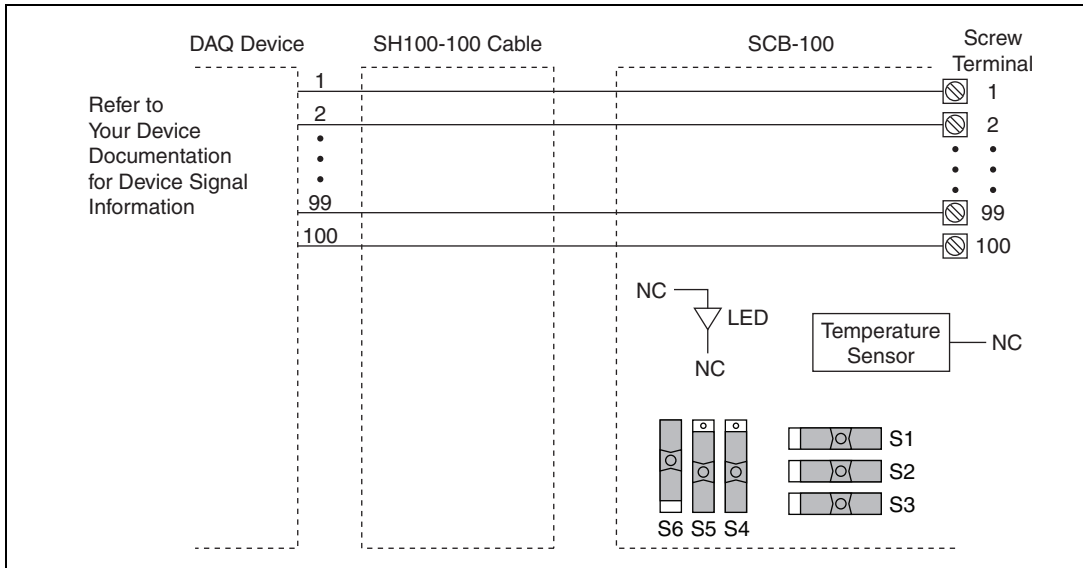
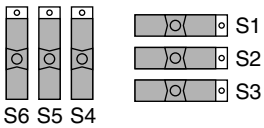
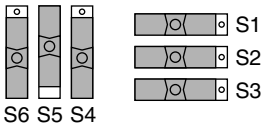
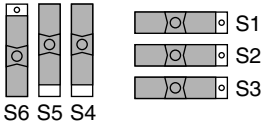
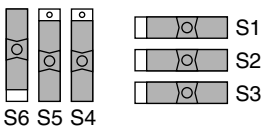

Figure 3. DIO/Passthrough Mode Switch Setting

Using the SCB-100 with MIO Devices

You can take measurements with the SCB-100 and MIO DAQ devices, such as E Series, in a number of ways. The SCB-100 has a temperature sensor for cold-junction compensation to accommodate thermocouples. Switches S4, S5, and S6 configure the temperature sensor for different analog input settings. Table 2 shows the different switch settings for MIO DAQ devices.

Table 2. MIO Device Switch Settings

Switch Setting	Description
 <p>S6 S5 S4</p> <p>S1 S2 S3</p>	<p>MIO with disabled temperature sensor mode (default configuration)—Move switches S1, S2, S3, S4, S5, and S6 to the positions shown at left. In this mode:</p> <ul style="list-style-type: none"> • The temperature sensor is not used. • AI 0 and AI 8 are available on screw terminals. • The signal accessory power LED (DS1) lights when the MIO device is powered on and connected to the SCB-100. <p>Refer to Figure 4 for a detailed diagram.</p>
 <p>S6 S5 S4</p> <p>S1 S2 S3</p>	<p>MIO with single-ended temperature sensor mode—Move switches S1, S2, S3, S4, S5, and S6 to the positions shown at left. In this mode:</p> <ul style="list-style-type: none"> • The temperature sensor can be read using AI 0 in referenced single-ended (RSE) mode. • AI 8 is available on a screw terminal. • The signal accessory power LED (DS1) lights when the MIO device is powered on and connected to the SCB-100. <p>Refer to Figure 4 for a detailed diagram.</p>
 <p>S6 S5 S4</p> <p>S1 S2 S3</p>	<p>MIO with differential temperature sensor mode—Move switches S1, S2, S3, S4, S5, and S6 to the positions shown at left. In this mode:</p> <ul style="list-style-type: none"> • The temperature sensor can be read using AI 0 and AI 8 in differential mode. • The signal accessory power LED (DS1) lights when the MIO device is powered on and connected to the SCB-100. <p>Refer to Figure 4 for a detailed diagram.</p>
 <p>S6 S5 S4</p> <p>S1 S2 S3</p>	<p>DIO/passthrough mode—You can use DIO/passthrough mode with an MIO device.</p> <p>Refer to Table 1 for configuration information and Figure 3 for a detailed diagram.</p>

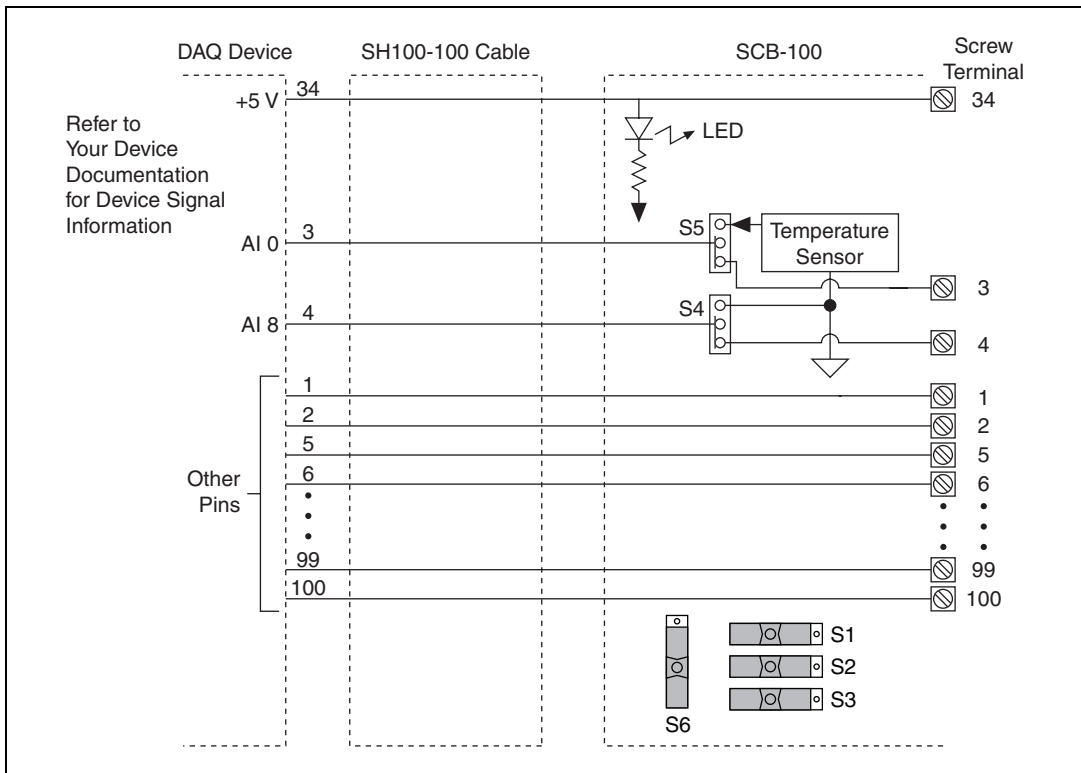

Figure 4. MIO Device Modes Switch Settings

Temperature Sensor Output and Accuracy

The SCB-100 temperature sensor outputs 10 mV/°C and has an accuracy of ± 0.5 °C.

You also can determine the temperature using the following formulas:

$$T_C = 100 \times V_i$$

$$T_K = T_C + 273.15$$

$$T_F = \left[\frac{9}{5} \times T_C \right] + 32$$

where V_i is the temperature sensor output voltage;

T_K is the temperature in Kelvin;

T_F and T_C are the temperature readings in degrees Fahrenheit and degrees Celsius, respectively.



Note Use the average of a large number of samples to obtain the most accurate reading. Noisy environments require averaging more samples for greater accuracy.

Connecting Nonreferenced or Floating Signal Sources to Analog Inputs

A floating signal source is a signal source that is not connected in any way to the building ground system but has an isolated ground-reference point. If an instrument or device has an isolated output, that instrument or device falls into the floating signal source category. Some examples of floating signal

sources are outputs for the following: thermocouples, transformers, battery-powered devices, optical isolators, and isolation amplifiers. The ground reference of a floating source must be tied to the ground of the MIO DAQ device to establish a local or onboard reference for the signal. If this reference is not established, erratic readings from the board will occur.

Differential Inputs

To provide a return path for the instrumentation amplifier bias currents, floating sources must have a 10 to 100 k Ω resistor connected to the AI GND signal line on one input if DC-coupled, or both inputs if AC-coupled. For detailed information on connections to floating signal sources and differential inputs, refer to the *E Series User Manual*.

Single-Ended Inputs

When measuring floating signal sources, configure the MIO DAQ device to supply a ground reference. Therefore, configure the MIO DAQ device for referenced single-ended (RSE) input. In this configuration, the negative input of the MIO DAQ device instrumentation amplifier is tied to the analog ground. For detailed information on connections to floating signal sources and single-ended inputs, refer to the *E Series User Manual*.

Connecting Ground-Referenced Signal Sources to Analog Inputs

A grounded signal source is connected in some way to the building system ground; therefore, the signal source is already connected to a common ground point with respect to the MIO DAQ device (assuming the host computer is plugged into the same power system). Nonisolated outputs of instruments and devices that plug into the building power system fall into this category.

Differential Inputs

If the MIO DAQ device is configured for differential inputs, ground-referenced signal sources connected to the SCB-100 board do not require special components added to the SCB-100 board. For detailed information on connections to ground-referenced signal sources and differential inputs, refer to the *E Series User Manual*.

Single-Ended Inputs

When measuring ground-referenced signals, the external signal supplies its own reference ground point, and the MIO DAQ device should not supply one. Therefore, configure the MIO DAQ device for nonreferenced, single-ended (NRSE) input mode. In this configuration, all of the signal grounds should be tied to AI SENSE, which connects to the negative input of the instrumentation amplifier on the MIO DAQ device. Referencing the signal to AI GND can cause inaccurate measurements resulting from an incorrect ground reference. For detailed information on connections to ground-referenced signal sources and single-ended inputs, refer to the *E Series User Manual*.

Using the SCB-100 for Thermocouple Measurements

The maximum voltage level generated by thermocouples is typically a few millivolts. Therefore, for best resolution, use an MIO DAQ device with a high gain.

Thermocouples can be measured in either differential or single-ended configurations. The differential configuration has better noise immunity, but the single-ended configuration has twice as many inputs. The MIO DAQ device must have a ground reference because thermocouples are floating signal sources. Therefore, you must install bias resistors if the MIO DAQ device is in differential mode. For single-ended configuration, use the referenced single-ended input configuration.

Cold-junction compensation with the SCB-100 is accurate only if the temperature sensor reading is close to the actual temperature of the screw terminals. Therefore, when reading thermocouples, keep the SCB-100 away from drafts or other temperature gradients such as those caused by heaters, radiators, fans, and warm equipment.

Optional Input Filtering and Broken Thermocouple Detection

To reduce noise, you can build a simple RC lowpass filter in the breadboard area.

Build broken-thermocouple-detection circuitry by connecting a high-value resistor between the positive input and +5 V. The value of this resistor is relatively unimportant; a few megaohms or more works fine. You can detect an open or defective thermocouple with a high-value resistor. If the thermocouple opens, the voltage measured across the input terminals rises to +5 V, a value much larger than any legitimate thermocouple voltage.

Sources of Error

When making thermocouple measurements with the SCB-100 and a MIO DAQ device, the possible sources of error are compensation, linearization, measurement, and thermocouple wire errors.

- *Compensation error* can arise from two sources—inaccuracy of the temperature sensor and temperature differences between the sensor and the screw terminals. The sensor on the SCB-100 board is specified to be accurate to ± 0.5 °C. Minimize temperature differences between the sensor and the screw terminals by keeping the SCB-100 board away from drafts, heaters, and warm equipment.
- *Linearization error* is a consequence of the polynomials being approximations of the true thermocouple output. The linearization error depends upon the degree of polynomial used.
- *Measurement error* is the result of inaccuracies in the MIO DAQ device, including gain and offset. If the MIO DAQ device is properly calibrated, the offset error should be zero. The only remaining error is a gain error of $\pm 0.08\%$ of full range (refer to the DAQ device specifications). If the input range is ± 10 V and the gain is 500, gain error contributes 0.0008 by 20 mV, or 16 μ V of error. If the Seebeck coefficient of a thermocouple is 32 μ V/°C, this measurement error adds 0.5 °C of uncertainty to the measurement. For best results, use a well-calibrated MIO DAQ device so that offsets can be ignored. Eliminate offset error by grounding one channel on the SCB-100 board and measuring the voltage. This value, the offset of the MIO DAQ device, then can be subtracted by software from all other readings.
- *Thermocouple wire error* is the result of inconsistencies in the thermocouple manufacturing process. These inconsistencies, or nonhomogeneities, are the result of defects or impurities in the thermocouple wire. The errors vary widely depending on the thermocouple type and even the gauge of wire used, but a value of ± 2 °C is typical.

For best results, use an average of at least 100 readings to reduce the effects of noise.

Removing the Board

You can remove the board from the enclosure to solder components into place. To remove the board, complete the following steps.

1. Disconnect the 100-pin cable from the SCB-100, if connected.
2. Remove the grounding screws on either side of the top cover with a Phillips #1 screwdriver.
3. Open the top cover.
4. Loosen the strain-relief screws with a Phillips #2 screwdriver.
5. Remove the signal wires from the screw terminals.
6. Remove the board mount screws and 100-pin connector screws.
7. Tilt the board up and pull it out of the enclosure.

Soldering, Desoldering, and Cutting Via Traces on the SCB-100 Board

The applications discussed here require you to make modifications to the printed circuit board, usually in the form of adding components or cutting jumpers. Use a low-wattage soldering iron (20 to 30 W) when soldering to the board.

To desolder on the SCB-100, vacuum-type tools work best. Use care when desoldering to avoid damaging component pads.

Use only rosin-core, electronic-grade solder. Acid-core solder damages the printed circuit board and components.

For each screw terminal, there are one or two vias next to the silkscreen showing the screw terminal number, as shown in Figure 2, number 8. The vias are shorted to the screw terminal so you can solder a component to the via to connect it to the screw terminal signal.

The trace between each pair of vias can be cut if needed.

Specifications

Specifications listed below are typical at 25 °C unless otherwise noted.

General

Number of screw terminals 101 (includes one no connect);
all I/O signals are available at screw terminals

Cold-junction sensor

Accuracy ±0.5 °C

Output 10 mV/°C



Caution Do not connect hazardous voltages ($\geq 42 V_{pk}/60$ VDC).

Power Requirement

Power consumption (at +5 VDC ±5%),

typical 10 mA with no signal conditioning installed



Note Limit the current drawn from the host computer's +5 VDC to about 800 mA, maximum.

Physical

Box dimensions 19.6 × 15.2 × 4.6 cm (7.7 × 6.0 × 1.8 in.)

Weight 897 g (1 lb 15.6 oz)

I/O connectors One 100-pin male 0.050 series shielded D-type connector

Screw terminals 101, including one No Connect (NC)

Wire gauge ≤26 AWG

Environmental

Operating temperature 0 to 70 °C

Storage temperature -55 to 125 °C

Relative humidity 5 to 90% noncondensing

Maximum altitude.....2,000 m

Pollution Degree (indoor use only).....2

Waste Electrical and Electronic Equipment (WEEE)



EU Customers At the end of their life cycle, all products *must* be sent to a WEEE recycling center. For more information about WEEE recycling centers and National Instruments WEEE initiatives, visit ni.com/environment/weee.htm.

Where to Go for Support

The National Instruments Web site is your complete resource for technical support. At ni.com/support you have access to everything from troubleshooting and application development self-help resources to email and phone assistance from NI Application Engineers.

National Instruments corporate headquarters is located at 11500 North Mopac Expressway, Austin, Texas, 78759-3504. National Instruments also has offices located around the world to help address your support needs. For telephone support in the United States, create your service request at ni.com/support and follow the calling instructions or dial 512 795 8248. For telephone support outside the United States, contact your local branch office:

Australia 1800 300 800, Austria 43 662 457990-0, Belgium 32 (0) 2 757 0020,
Brazil 55 11 3262 3599, Canada 800 433 3488, China 86 21 5050 9800,
Czech Republic 420 224 235 774, Denmark 45 45 76 26 00, Finland 385 (0) 9 725 72511,
France 33 (0) 1 48 14 24 24, Germany 49 89 7413130, India 91 80 41190000, Israel 972 3 6393737,
Italy 39 02 413091, Japan 81 3 5472 2970, Korea 82 02 3451 3400, Lebanon 961 (0) 1 33 28 28,
Malaysia 1800 887710, Mexico 01 800 010 0793, Netherlands 31 (0) 348 433 466,
New Zealand 0800 553 322, Norway 47 (0) 66 90 76 60, Poland 48 22 3390150,
Portugal 351 210 311 210, Russia 7 495 783 6851, Singapore 1800 226 5886,
Slovenia 386 3 425 42 00, South Africa 27 0 11 805 8197, Spain 34 91 640 0085,
Sweden 46 (0) 8 587 895 00, Switzerland 41 56 2005151, Taiwan 886 02 2377 2222,
Thailand 662 278 6777, Turkey 90 212 279 3031, United Kingdom 44 (0) 1635 523545

National Instruments, NI, ni.com, and LabVIEW are trademarks of National Instruments Corporation. Refer to the *Terms of Use* section on ni.com/legal for more information about National Instruments trademarks. Other product and company names mentioned herein are trademarks or trade names of their respective companies. For patents covering National Instruments products, refer to the appropriate location: **Help»Patents** in your software, the `patents.txt` file on your CD, or ni.com/patents.