

TBX-24F FEEDTHROUGH TERMINAL BLOCK

This guide describes how to install and use the National Instruments TBX-24F feedthrough terminal block with an SCXI system.

The TBX-24F is a DIN-rail mountable terminal block you can use with any SCXI module. It directly connects to the SCXI-1161, which has internal terminal blocks. It connects to any other SCXI module through an SCXI terminal block or direct connections, such as BNC or thermocouple connectors. The TBX-24F mounts on most European standard DIN EN mounting rails.

Conventions



The following conventions are used in this guide:

This icon denotes a note, which alerts you to important information.



This icon denotes a caution, which advises you of precautions to take to avoid injury, data loss, or a system crash. When this symbol is marked on the product, see the [Safety Information](#) section for precautions to take.

bold

Bold text denotes items that you must select or click on in the software, such as menu items and dialog box options. Bold text also denotes parameter names.

italic

Italic text denotes variables, emphasis, a cross reference, or an introduction to a key concept. This font also denotes text that is a placeholder for a word or value that you must supply.

monospace

Text in this font denotes text or characters that you should enter from the keyboard, sections of code, programming examples, and syntax examples. This font is also used for the proper names of disk drives, paths, directories, programs, subprograms, subroutines, device names, functions, operations, variables, filenames and extensions, and code excerpts.

FCC/Canada Radio Frequency Interference Compliance¹

Determining FCC Class

The Federal Communications Commission (FCC) has rules to protect wireless communications from interference. The FCC places digital electronics into two classes. These classes are known as Class A (for use in industrial-commercial locations only) or Class B (for use in residential or commercial locations). Depending on where it is operated, this product could be subject to restrictions in the FCC rules. In Canada, the Department of Communications (DOC), of Industry Canada, regulates wireless interference in much the same way.

Digital electronics emit weak signals during normal operation that can affect radio, television, or other wireless products. By examining the product you purchased, you can determine the FCC Class and therefore which of the two FCC/DOC Warnings apply in the following sections. Some products may not be labeled at all for FCC; if so, the reader should then assume these are Class A devices.

FCC Class A products only display a simple warning statement of one paragraph in length regarding display interference and undesired operation. Most of our products are FCC Class A. The FCC rules have restrictions regarding the locations where FCC Class A products can be operated.

FCC Class B products display either a FCC ID code, starting with the letters **EXN**, or the FCC Class B compliance mark that appears as shown below.

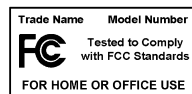

Consult the FCC Web site at fcc.gov for more information.

¹ Certain exemptions may apply in the USA, see FCC Rules §15.103 Exempted devices, and §15.105(c). Also available in sections of CFR 47.

FCC/DOC Warnings

This equipment generates and uses radio frequency energy and, if not installed and used in strict accordance with the instructions in this manual and the CE Mark Declaration of Conformity¹ (DoC), may cause interference to radio and television reception. Classification requirements are the same for the FCC and the DOC.

Changes or modifications not expressly approved by NI could void the user's authority to operate the equipment under the FCC Rules.

Class A

Federal Communications Commission

This equipment has been tested and found to comply with the limits for a Class A digital device, pursuant to part 15 of the FCC Rules. These limits are designed to provide reasonable protection against harmful interference when the equipment is operated in a commercial environment.

This equipment generates, uses, and can radiate radio frequency energy and, if not installed and used in accordance with the instruction manual, may cause harmful interference to radio communications. Operation of this equipment in a residential area is likely to cause harmful interference in which case the user will be required to correct the interference at his own expense.

Canadian Department of Communications

This Class A digital apparatus meets all requirements of the Canadian Interference-Causing Equipment Regulations.

Cet appareil numérique de la classe A respecte toutes les exigences du Règlement sur le matériel brouilleur du Canada.

Class B

Federal Communications Commission

This equipment has been tested and found to comply with the limits for a Class B digital device, pursuant to part 15 of the FCC Rules. These limits are designed to provide reasonable protection against harmful interference in a residential installation. This equipment generates, uses, and can radiate radio frequency energy and, if not installed and used in accordance with the instructions, may cause harmful interference to radio communications. However, there is no guarantee that interference will not occur in a particular installation. If this equipment does cause harmful interference

¹ The CE Mark DoC contains important supplementary information and instructions for the user or installer.

to radio or television reception, which can be determined by turning the equipment off and on, the user is encouraged to try to correct the interference by one or more of the following measures:

- Reorient or relocate the receiving antenna.
- Increase the separation between the equipment and receiver.
- Connect the equipment into an outlet on a circuit different from that to which the receiver is connected.
- Consult the dealer or an experienced radio/TV technician for help.

Canadian Department of Communications

This Class B digital apparatus meets all requirements of the Canadian Interference-Causing Equipment Regulations.

Cet appareil numérique de la classe B respecte toutes les exigences du Règlement sur le matériel brouilleur du Canada.

Compliance to EU Directives

Readers in the European Union (EU) must refer to the Manufacturer's DoC for information¹ pertaining to the CE Mark compliance scheme. The Manufacturer includes a DoC for most every hardware product except for those bought for OEMs, if also available from an original manufacturer that also markets in the EU, or where compliance is not required as for electrically benign apparatus or cables.

To obtain the DoC for this product, click **Declaration of Conformity** at ni.com/hardref.nsf. This Web site lists the DoCs by product family. Select the appropriate product family, followed by the product, and a link to the DoC appears in Adobe Acrobat format. Click the Acrobat icon to download or read the DoC.

Safety Information

The following section contains important safety information that you *must* follow when installing and using the product.

Do *not* operate the product in a manner not specified in this document. Misuse of the product can result in a hazard. You can compromise the safety protection built into the product if the product is damaged in any way. If the product is damaged, return it to NI for repair.

¹ The CE Mark DoC contains important supplementary information and instructions for the user or installer.

Do *not* substitute parts or modify the product except as described in this guide.

Do *not* operate the product in an explosive atmosphere or where there may be flammable gases or fumes. Operate the product only at or below the pollution degree stated in the *Specifications* section. Pollution is foreign matter in a solid, liquid, or gaseous state that can reduce dielectric strength or surface resistivity. The following is a description of pollution degrees:

- Pollution degree 1 means no pollution or only dry, nonconductive pollution occurs. The pollution has no influence.
- Pollution degree 2 means that only nonconductive pollution occurs in most cases. Occasionally, however, a temporary conductivity caused by condensation must be expected.
- Pollution degree 3 means that conductive pollution occurs, or dry, nonconductive pollution occurs that becomes conductive due to condensation.

Clean the product with a soft nonmetallic brush. Make sure the product is completely dry and free from contaminants before returning it to service.

You *must* insulate signal connections for the maximum voltage for which the product is rated. Do *not* exceed the maximum ratings for the product. Remove power from signal lines before connecting them to or disconnecting them from the product.

Operate this product only at or below the installation category stated in the *Specifications* section.

The following is a description of installation categories:

- Installation category I is for measurements performed on circuits not directly connected to MAINS¹. This category is a signal level such as voltages on a printed wire board (PWB) on the secondary of an isolation transformer.

Examples of installation category I are measurements on circuits not derived from MAINS and specially protected (internal) MAINS-derived circuits.

¹ MAINS is defined as the electricity supply system to which the equipment concerned is designed to be connected either for powering the equipment or for measurement purposes.

- Installation category II is for measurements performed on circuits directly connected to the low-voltage installation. This category refers to local-level distribution such as that provided by a standard wall outlet.

Examples of installation category II are measurements on household appliances, portable tools, and similar equipment.

- Installation category III is for measurements performed in the building installation. This category is a distribution level referring to hardwired equipment that does not rely on standard building insulation.

Examples of installation category III include measurements on distribution circuits and circuit breakers. Other examples of installation category III are wiring including cables, bus-bars, junction boxes, switches, socket outlets in the building/fixed installation, and equipment for industrial use, such as stationary motors with a permanent connection to the building/fixed installation.

- Installation category IV is for measurements performed at the source of the low-voltage (<1,000 V) installation.

Examples of category IV are electric meters, and measurements on primary overcurrent protection devices and ripple-control units.

Below is a diagram of a sample installation.

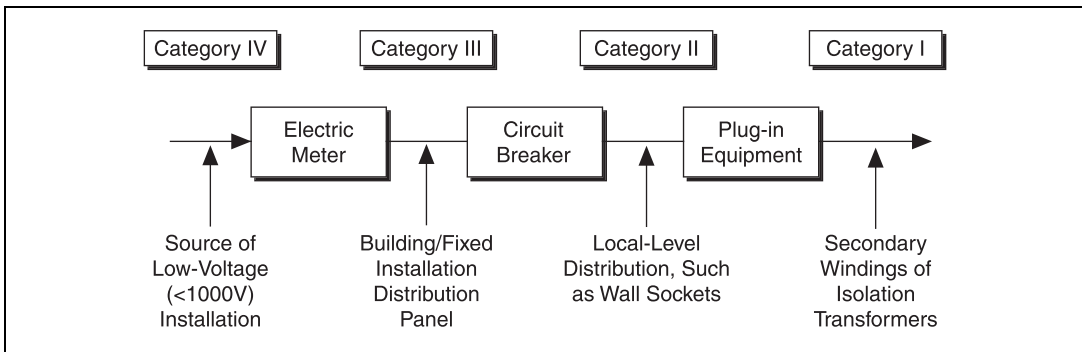

What You Need to Get Started

To install and use the TBX-24F, you need the following items:

- TBX-24F feedthrough terminal block
- [TBX-24F Feedthrough Terminal Block Installation Guide](#)
- Blank adhesive labels to identify signals
- 1/8 in. flat blade screwdriver
- SCXI chassis and relevant documentation
- SCXI module and relevant documentation
- SCXI terminal block and relevant documentation



Note If you are connecting the TBX-24F to an SCXI-1161 module, you do not need an SCXI terminal block. The SCXI-1161 features internal terminal blocks. If the module uses direct connections, such as BNC or thermocouple connectors, you do not need a terminal block.

Installing the TBX-24F

If you are using the National Instruments TBX rack-mount assembly, refer to the *TBX Rack-Mount Kit Installation Guide* for instructions on mounting the TBX assembly onto the rack. If you are not using this rack-mount assembly, snap the TBX-24F onto the DIN rail with a firm push.

To remove the TBX-24F from the DIN rail, place a flat blade screwdriver into the slot above its base and pry it from the rail.

Connecting Signals to the TBX-24F

Refer to the SCXI module user manual for examples of how to connect field signals and loads. Figure 1 shows the TBX-24F connected directly to an SCXI-1161 module and connected to another SCXI module using a terminal block. Follow these instructions to route the signals through the TBX-24F:

1. Power off the SCXI chassis and the computer that contains the E Series data acquisition (DAQ) device or disconnect the device from the SCXI chassis.



Note Use insulated wires to connect the TBX-24F DIN-rail mountable terminals to the SCXI terminal block or module. Refer to the *Specifications* section to determine the range of acceptable wire gauges for your region.

2. Disconnect all power from the signal sources.
3. Connect the signal wires to the TBX-24F terminal plug that connects to the corresponding terminal for the SCXI module. Refer to Figure 1.

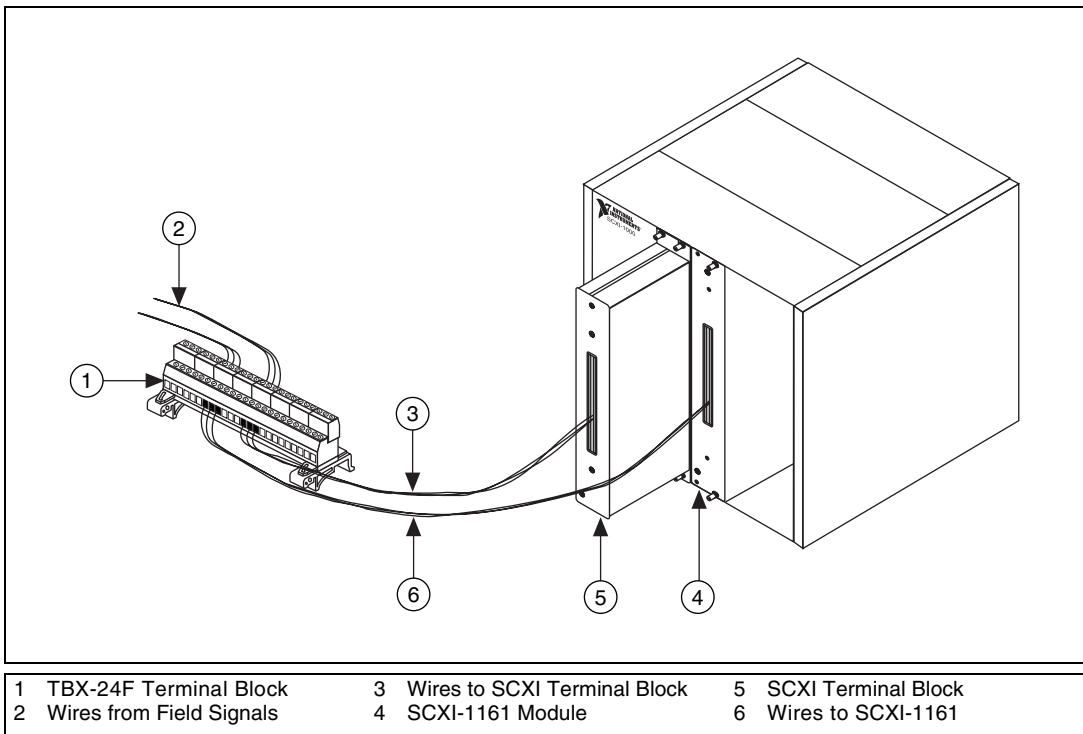

Figure 1. TBX-24F Terminal Block Connection

4. Write the signal names on the adhesive labels and affix the labels to the TBX-24F terminals. Refer to Figure 2.

Figure 2 shows a unique feature of the TBX-24F. There are eight removable terminal plugs so you can disconnect field wires from the system without disconnecting them from the screw terminals. For example, you can remove the terminal plug with field wires intact and connect the field wires to another terminal block or measuring device. The terminal plugs are keyed so that you can insert them in only one direction.

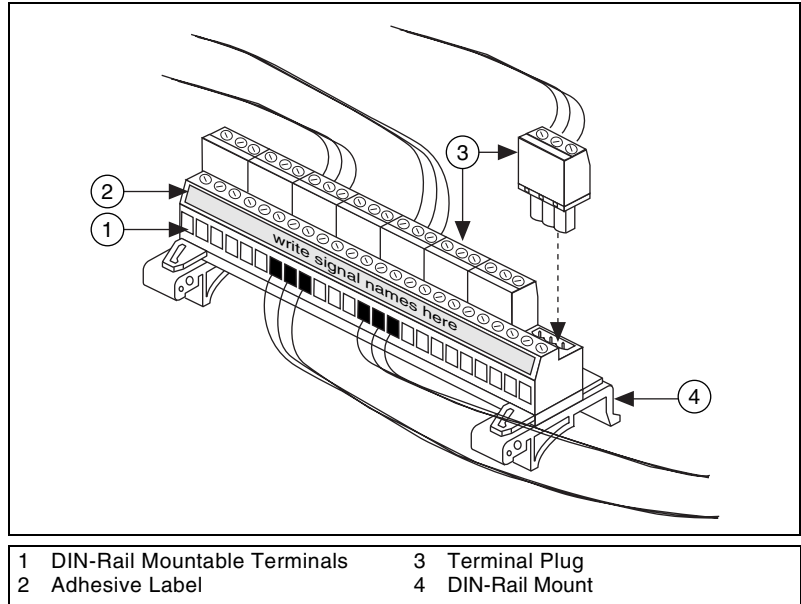

Figure 2. TBX-24F Terminal Block Components



Caution Do *not* use the pluggable connectors to connect or disconnect live circuits.

Specifications

Electrical

Apply the ratings according to the installation location(s). If none of the locations apply, use the ratings for Europe. For all locations, the maximum current ratings have temperature deratings as shown in Figure 3.

The temperature derating curve shows the maximum current for a given ambient temperature.

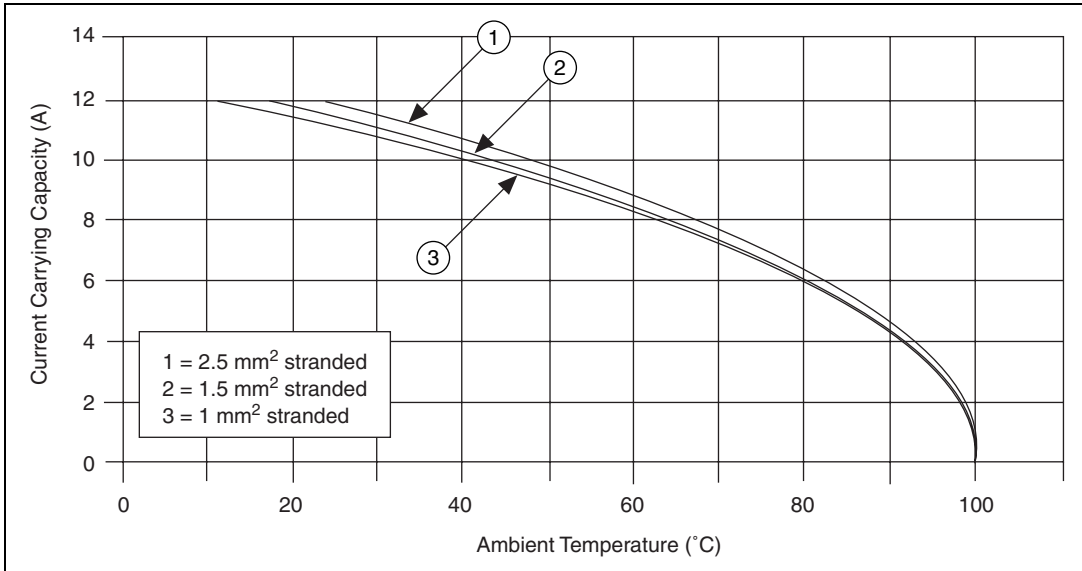

Figure 3. Temperature Deratings for Maximum Current Ratings

USA (UL approved limits)

Maximum working voltage300 V

Maximum current (under 30 V).....12 A

Maximum current (above 30 V)10 A

Wire gauge.....30 to 12 AWG

Canada (CSA approved limits)

Maximum working voltage300 V

Maximum current (under 30 V).....12 A

Maximum current (above 30 V)..... 10 A
Wire gauge 28 to 12 AWG

Europe (IEC/DIN/VDE definitions, approved limits, and defaults for all locations)

Maximum working voltage 300 V
Installation category II
Pollution degree 2
Maximum current..... 12 A
Wire size (solid and stranded)..... 2.5 A/mm² or 24 to 12 AWG

Physical

Insulation material group I
Insulation material..... PA
Flammability rating..... V-2 (base), V-0 (plugs)
Altitude..... 2000 m
Insulation stripping length 7 mm (0.276 in)
Color..... green
Internal cylindrical size..... A3 (IEC 947-1:1998)
Torque 0.5 to 0.6 N•m
(4.425 to 5.310 lbf•in)
Thread M3
Temperature indexes RTI/Ti 125/100

Environmental

Pollution degree (indoor use only)	2
Humidity	10 to 90% RH, noncondensing
Storage temperature	-20 to 100 °C
Operating temperature	0 to 100 °C (see Figure 3 for derating versus temperature)

Technical Support Resources

NI Web Support

NI Web support is your first stop for help in solving installation, configuration, and application problems and questions. Online problem-solving and diagnostic resources include frequently asked questions, knowledge bases, product-specific troubleshooting wizards, manuals, drivers, software updates, and more. Web support is available through the Technical Support section of ni.com.

Worldwide Support

NI has offices located around the world to help address your support needs. You can access our branch office Web sites from the Worldwide Offices section of ni.com. Branch office Web sites provide up-to-date contact information, support phone numbers, e-mail addresses, and current events.

If you have searched the technical support resources on our Web site and still cannot find the answers you need, contact your local office or NI corporate. For telephone support in the United States, dial 512 795 8248. For telephone support outside the United States, contact your local branch office:

Australia 03 9879 5166, Austria 0662 45 79 90 0, Belgium 02 757 00 20, Brazil 011 3262 3599, Canada (Calgary) 403 274 9391, Canada (Montreal) 514 288 5722, Canada (Ottawa) 613 233 5949, Canada (Québec) 514 694 8521, Canada (Toronto) 905 785 0085, China (Shanghai) 021 6555 7838, China (ShenZhen) 0755 3904939, Czech Republic 02 2423 5774, Denmark 45 76 26 00, Finland 09 725 725 11, France 01 48 14 24 24, Germany 089 741 31 30, Greece 30 1 42 96 427, Hong Kong 2645 3186, India 91 80 535 5406, Israel 03 6393737, Italy 02 413091, Japan 03 5472 2970, Korea 02 3451 3400, Malaysia 603 9596711, Mexico 001 800 010 0793, Netherlands 0348 433466, New Zealand 09 914 0488, Norway 32 27 73 00, Poland 0 22 528 94 06, Portugal 351 210 311 210, Russia 095 238 7139, Singapore 2265886, Slovenia 386 3 425 4200, South Africa 11 805 8197, Spain 91 640 0085, Sweden 08 587 895 00, Switzerland 056 200 51 51, Taiwan 02 2528 7227, United Kingdom 01635 523545