

# *PXI*

---

## **NI PXI-1052 User Manual**

## **Worldwide Technical Support and Product Information**

ni.com

### **National Instruments Corporate Headquarters**

11500 North Mopac Expressway Austin, Texas 78759-3504 USA Tel: 512 683 0100

### **Worldwide Offices**

Australia 1800 300 800, Austria 43 0 662 45 79 90 0, Belgium 32 0 2 757 00 20, Brazil 55 11 3262 3599, Canada (Calgary) 403 274 9391, Canada (Ottawa) 613 233 5949, Canada (Québec) 450 510 3055, Canada (Toronto) 905 785 0085, Canada (Vancouver) 514 685 7530, China 86 21 6555 7838, Czech Republic 420 224 235 774, Denmark 45 45 76 26 00, Finland 385 0 9 725 725 11, France 33 0 1 48 14 24 24, Germany 49 0 89 741 31 30, Greece 30 2 10 42 96 427, India 91 80 51190000, Israel 972 0 3 6393737, Italy 39 02 413091, Japan 81 3 5472 2970, Korea 82 02 3451 3400, Malaysia 603 9131 0918, Mexico 001 800 010 0793, Netherlands 31 0 348 433 466, New Zealand 0800 553 322, Norway 47 0 66 90 76 60, Poland 48 22 3390150, Portugal 351 210 311 210, Russia 7 095 783 68 51, Singapore 65 6226 5886, Slovenia 386 3 425 4200, South Africa 27 0 11 805 8197, Spain 34 91 640 0085, Sweden 46 0 8 587 895 00, Switzerland 41 56 200 51 51, Taiwan 886 2 2528 7227, Thailand 662 992 7519, United Kingdom 44 0 1635 523545

For further support information, refer to the *Technical Support and Professional Services* appendix. To comment on the documentation, send email to [techpubs@ni.com](mailto:techpubs@ni.com).

© 2004 National Instruments Corporation. All rights reserved.

# Important Information

---

## Warranty

The NI PXI-1052 is warranted against defects in materials and workmanship for a period of one year from the date of shipment, as evidenced by receipts or other documentation. National Instruments will, at its option, repair or replace equipment that proves to be defective during the warranty period. This warranty includes parts and labor.

The media on which you receive National Instruments software are warranted not to fail to execute programming instructions, due to defects in materials and workmanship, for a period of 90 days from date of shipment, as evidenced by receipts or other documentation. National Instruments will, at its option, repair or replace software media that do not execute programming instructions if National Instruments receives notice of such defects during the warranty period. National Instruments does not warrant that the operation of the software shall be uninterrupted or error free.

A Return Material Authorization (RMA) number must be obtained from the factory and clearly marked on the outside of the package before any equipment will be accepted for warranty work. National Instruments will pay the shipping costs of returning to the owner parts which are covered by warranty.

National Instruments believes that the information in this document is accurate. The document has been carefully reviewed for technical accuracy. In the event that technical or typographical errors exist, National Instruments reserves the right to make changes to subsequent editions of this document without prior notice to holders of this edition. The reader should consult National Instruments if errors are suspected. In no event shall National Instruments be liable for any damages arising out of or related to this document or the information contained in it.

EXCEPT AS SPECIFIED HEREIN, NATIONAL INSTRUMENTS MAKES NO WARRANTIES, EXPRESS OR IMPLIED, AND SPECIFICALLY DISCLAIMS ANY WARRANTY OF MERCHANTABILITY OR FITNESS FOR A PARTICULAR PURPOSE. CUSTOMER'S RIGHT TO RECOVER DAMAGES CAUSED BY FAULT OR NEGLIGENCE ON THE PART OF NATIONAL INSTRUMENTS SHALL BE LIMITED TO THE AMOUNT THEREFORE PAID BY THE CUSTOMER. NATIONAL INSTRUMENTS WILL NOT BE LIABLE FOR DAMAGES RESULTING FROM LOSS OF DATA, PROFITS, USE OF PRODUCTS, OR INCIDENTAL OR CONSEQUENTIAL DAMAGES, EVEN IF ADVISED OF THE POSSIBILITY THEREOF. This limitation of the liability of National Instruments will apply regardless of the form of action, whether in contract or tort, including negligence. Any action against National Instruments must be brought within one year after the cause of action accrues. National Instruments shall not be liable for any delay in performance due to causes beyond its reasonable control. The warranty provided herein does not cover damages, defects, malfunctions, or service failures caused by owner's failure to follow the National Instruments installation, operation, or maintenance instructions; owner's modification of the product; owner's abuse, misuse, or negligent acts; and power failure or surges, fire, flood, accident, actions of third parties, or other events outside reasonable control.

## Copyright

Under the copyright laws, this publication may not be reproduced or transmitted in any form, electronic or mechanical, including photocopying, recording, storing in an information retrieval system, or translating, in whole or in part, without the prior written consent of National Instruments Corporation.

## Trademarks

CVI™, LabVIEW™, Measurement Studio™, National Instruments™, NI™, ni.com™, NI-DAQ™, NI-VISA™, and SCXI™ are trademarks of National Instruments Corporation.

Product and company names mentioned herein are trademarks or trade names of their respective companies.

## Patents

For patents covering National Instruments products, refer to the appropriate location: **Help»Patents** in your software, the `patents.txt` file on your CD, or [ni.com/patents](http://ni.com/patents).

## WARNING REGARDING USE OF NATIONAL INSTRUMENTS PRODUCTS

(1) NATIONAL INSTRUMENTS PRODUCTS ARE NOT DESIGNED WITH COMPONENTS AND TESTING FOR A LEVEL OF RELIABILITY SUITABLE FOR USE IN OR IN CONNECTION WITH SURGICAL IMPLANTS OR AS CRITICAL COMPONENTS IN ANY LIFE SUPPORT SYSTEMS WHOSE FAILURE TO PERFORM CAN REASONABLY BE EXPECTED TO CAUSE SIGNIFICANT INJURY TO A HUMAN.

(2) IN ANY APPLICATION, INCLUDING THE ABOVE, RELIABILITY OF OPERATION OF THE SOFTWARE PRODUCTS CAN BE IMPAIRED BY ADVERSE FACTORS, INCLUDING BUT NOT LIMITED TO FLUCTUATIONS IN ELECTRICAL POWER SUPPLY, COMPUTER HARDWARE MALFUNCTIONS, COMPUTER OPERATING SYSTEM SOFTWARE FITNESS, FITNESS OF COMPILERS AND DEVELOPMENT SOFTWARE USED TO DEVELOP AN APPLICATION, INSTALLATION ERRORS, SOFTWARE AND HARDWARE COMPATIBILITY PROBLEMS, MALFUNCTIONS OR FAILURES OF ELECTRONIC MONITORING OR CONTROL DEVICES, TRANSIENT FAILURES OF ELECTRONIC SYSTEMS (HARDWARE AND/OR SOFTWARE), UNANTICIPATED USES OR MISUSES, OR ERRORS ON THE PART OF THE USER OR APPLICATIONS DESIGNER (ADVERSE FACTORS SUCH AS THESE ARE HEREAFTER COLLECTIVELY TERMED "SYSTEM FAILURES"). ANY APPLICATION WHERE A SYSTEM FAILURE WOULD CREATE A RISK OF HARM TO PROPERTY OR PERSONS (INCLUDING THE RISK OF BODILY INJURY AND DEATH) SHOULD NOT BE RELIANT SOLELY UPON ONE FORM OF ELECTRONIC SYSTEM DUE TO THE RISK OF SYSTEM FAILURE. TO AVOID DAMAGE, INJURY, OR DEATH, THE USER OR APPLICATION DESIGNER MUST TAKE REASONABLY PRUDENT STEPS TO PROTECT AGAINST SYSTEM FAILURES, INCLUDING BUT NOT LIMITED TO BACK-UP OR SHUT DOWN MECHANISMS. BECAUSE EACH END-USER SYSTEM IS CUSTOMIZED AND DIFFERS FROM NATIONAL INSTRUMENTS' TESTING PLATFORMS AND BECAUSE A USER OR APPLICATION DESIGNER MAY USE NATIONAL INSTRUMENTS PRODUCTS IN COMBINATION WITH OTHER PRODUCTS IN A MANNER NOT EVALUATED OR CONTEMPLATED BY NATIONAL INSTRUMENTS, THE USER OR APPLICATION DESIGNER IS ULTIMATELY RESPONSIBLE FOR VERIFYING AND VALIDATING THE SUITABILITY OF NATIONAL INSTRUMENTS PRODUCTS WHENEVER NATIONAL INSTRUMENTS PRODUCTS ARE INCORPORATED IN A SYSTEM OR APPLICATION, INCLUDING, WITHOUT LIMITATION, THE APPROPRIATE DESIGN, PROCESS AND SAFETY LEVEL OF SUCH SYSTEM OR APPLICATION.

# Contents

---

## About This Manual

Conventions .....	vii
Related Documentation.....	viii

## Chapter 1

### Getting Started

Unpacking .....	1-1
What You Need to Get Started .....	1-1
Key Features .....	1-2
Chassis Description.....	1-4
Optional Equipment .....	1-5
PXI-1052 Backplane Overview .....	1-5
Interoperability with CompactPCI .....	1-6
System Controller Slot .....	1-6
Star Trigger Slot .....	1-6
Peripheral Slots.....	1-6
Local Bus .....	1-7
SCXI Control Slot .....	1-7
Trigger Bus .....	1-7
System Reference Clock.....	1-8
SCXI Subsystem Overview .....	1-8

## Chapter 2

### Installation and Configuration

Safety Information .....	2-1
Chassis Cooling Considerations .....	2-2
Providing Adequate Clearance .....	2-2
Setting Fan Speed .....	2-3
Installing Filler Panels .....	2-3
Installing Slot Blockers .....	2-3
Rack Mounting .....	2-3
Connecting Safety Ground.....	2-4
Connecting to Power Source.....	2-4
Power Switch LED Indicators .....	2-5
Installing a PXI Controller.....	2-6
Installing PXI Modules .....	2-8
Installing Optional PXI Filler Panels .....	2-9

Installing SCXI Modules .....	2-10
Installing Optional SCXI-1360 Filler Panels .....	2-10
PXI System Configuration with MAX .....	2-10
Basic PXI System Configuration .....	2-11
Trigger Configuration in MAX .....	2-12
Using System Configuration and Initialization Files .....	2-13
SCXI Configuration with MAX .....	2-13
Configure the Chassis .....	2-14
Configure the SCXI Modules .....	2-15
Test the Chassis .....	2-16
Configure Channels and Tasks .....	2-16
Configure a Task in NI-DAQmx .....	2-17
Configure Global Channels for NI-DAQmx .....	2-18
Remote Voltage Monitoring and Control .....	2-19

## **Chapter 3**

### **Maintenance**

Service Interval .....	3-1
Preparation .....	3-1
Cleaning .....	3-2
Interior Cleaning .....	3-2
Exterior Cleaning .....	3-2
Cleaning and Replacing the Fan Filters .....	3-3
Resetting the AC Mains Circuit Breaker .....	3-3

## **Appendix A**

### **Specifications**

## **Appendix B**

### **Pinouts**

## **Appendix C**

### **Technical Support and Professional Services**

## **Glossary**

## **Index**

# About This Manual

---

The *NI PXI-1052 User Manual* contains information about installing, configuring, using, and maintaining the NI PXI-1052 chassis.

## Conventions

---

The following conventions are used in this manual:

»

The » symbol leads you through nested menu items and dialog box options to a final action. The sequence **File»Page Setup»Options** directs you to pull down the **File** menu, select the **Page Setup** item, and select **Options** from the last dialog box.



This icon denotes a note, which alerts you to important information.



This icon denotes a caution, which advises you of precautions to take to avoid injury, data loss, or a system crash. When this symbol is marked on the product, refer to the *Read Me First: Safety and Radio-Frequency Interference* document, shipped with the product, for precautions to take.



When symbol is marked on a product it denotes a warning advising you to take precautions to avoid electrical shock.



When symbol is marked on a product it denotes a component that may be hot. Touching this component may result in bodily injury.

**bold**

Bold text denotes items that you must select or click in the software, such as menu items and dialog box options. Bold text also denotes parameter names.

*italic*

Italic text denotes variables, emphasis, a cross reference, or an introduction to a key concept. This font also denotes text that is a placeholder for a word or value that you must supply.

monospace

Text in this font denotes text or characters that you should enter from the keyboard, sections of code, programming examples, and syntax examples. This font is also used for the proper names of disk drives, paths, directories, programs, subprograms, subroutines, device names, functions, operations, variables, filenames, and extensions.

## Related Documentation

---

The following documents contain information that you might find helpful as you read this manual:

- *DAQ Quick Start Guide*
- *SCXI Quick Start Guide*
- DAQ user manuals and installation guides—This documentation has detailed information about the DAQ hardware that plugs into or is connected to the chassis. Use these documents for hardware installation and configuration instructions, specification information about the DAQ hardware, and application hints.
- *Getting Started with SCXI*—Read this manual second. It gives an overview of the SCXI system and contains the most commonly needed information for modules, chassis, and software.
- SCXI user manuals and installation guides—Read these documents next for information about signal connections and module configuration. They also explain in greater detail how the module works and contain application tips and strategies.
- *PXI Hardware Specification, Revision 2.1*
- *CompactPCI Specification PICMG 2.0 R 3.0*
- *PXI Software Specification, Revision 2.1*
- *SCXIBus System Specification*
- IEEE 1101.1-1991, *IEEE Standard for Mechanical Core Specifications for Microcomputers Using IEC 603-2 Connectors*
- IEEE 1101.10, *IEEE Standard for Additional Mechanical Specifications for Microcomputers Using IEEE 1101.1 Equipment Practice*



**Note** While some of the NI documentation listed in this section is included with your kit, all of the NI documents are available at [ni.com/manuals](http://ni.com/manuals). The listed specifications are not available through NI. They can be obtained from their respective organizations.

---

# Getting Started

This chapter describes the key features of the PXI-1052 chassis and lists the kit contents and optional equipment you can order from NI.

## Unpacking

---

- Carefully inspect the shipping container and the chassis for damage.
- Inspect the chassis for visible damage to the metal work. Make sure all handles, hardware, and switches are undamaged.
- Inspect the inner chassis for any possible damage, debris, or detached components. If damage appears to have been caused during shipment, file a claim with the carrier.
- Retain the packing material for possible inspection and/or reshipment.



**Caution** Many components within the chassis are susceptible to static discharge damage. Observe standard precautions for static-sensitive devices while handling the chassis.

## What You Need to Get Started

---

The PXI-1052 kit contains the following items:

- PXI-1052 chassis
- AC power cable—refer to Table 1-1 for AC power cables
- NI PXI-1052 User Manual*
- Read Me First: Safety and Radio-Frequency Interference*
- NI PXI Chassis Resource CD*
- PXI Filler panels
- (Optional) SCXI Filler panels
- (Optional) Chassis number labels

**Table 1-1.** AC Power Cables

<b>Power Cable</b>	<b>Reference Standards</b>
Standard 120 V (USA)	ANSI C73.11/NEMA 5-15-P/IEC83
North America 120 V	ANSI C73.20/NEMA 5-15-P/IEC83
Switzerland 220 V	SEV
Universal Euro 230 V	CEE (7), II, IV, VII IEC83
Australia 240 V	AS C112
United Kingdom 230 V	BS 1363/IEC83

If you are missing any of the items in Table 1-1, or if you have the incorrect AC power cable, contact NI through the information given in Appendix C, *Technical Support and Professional Services*.

## Key Features

---

The PXI-1052 chassis combines a high-performance 4-slot PXI subsystem with an 8-slot SCXI subsystem, offering a complete solution for signal conditioning and switching applications. The PXI-1052 complies with the *PXI Hardware Specification, Revision 2.1*, offering advanced timing and synchronization features. The eight SCXI slots integrate signal conditioning modules into the PXI system. These modules provide analog and digital signal conditioning, isolation, and other functions. The PXI-1052 has a high-output power supply and structural design that is optimized for use in a wide range of applications.

The PXI-1052 has a built-in digital and analog bus between the PXI and SCXI subsystems that allows a DAQ/DMM module in the fourth PXI slot to control the SCXI subsystem without additional cables. The SCXI subsystem provides a low-noise environment for signal conditioning instrumentation. It supplies power and control circuitry for SCXI modules.

The key features of the PXI-1052 include the following:

- PXI and CompactPCI (PICMG 2.0 R 3.0) module compatibility
- 3U-sized, 4-slot PXI chassis subsystem
- Universal AC input: automatic voltage and frequency ranging
- Temperature-sensing module that adjusts fan speed based on air-intake temperature to minimize audible noise

- Over-current protection through push-reset circuit breaker (no AC-input fuse to replace)
- Remote PXI voltage monitoring and inhibit through a rear-panel connector
- On/Off (Standby) power switch on the front panel for easy access
- SCXI power switch on the chassis rear panel
- Front-panel LED that indicates power supply failure
- Handle for portability
- Tilt feet for bench-top applications
- Rack mountable

# Chassis Description

Figure 1-1 and Figure 1-2 show the key features of the PXI-1052 chassis front and rear panels.

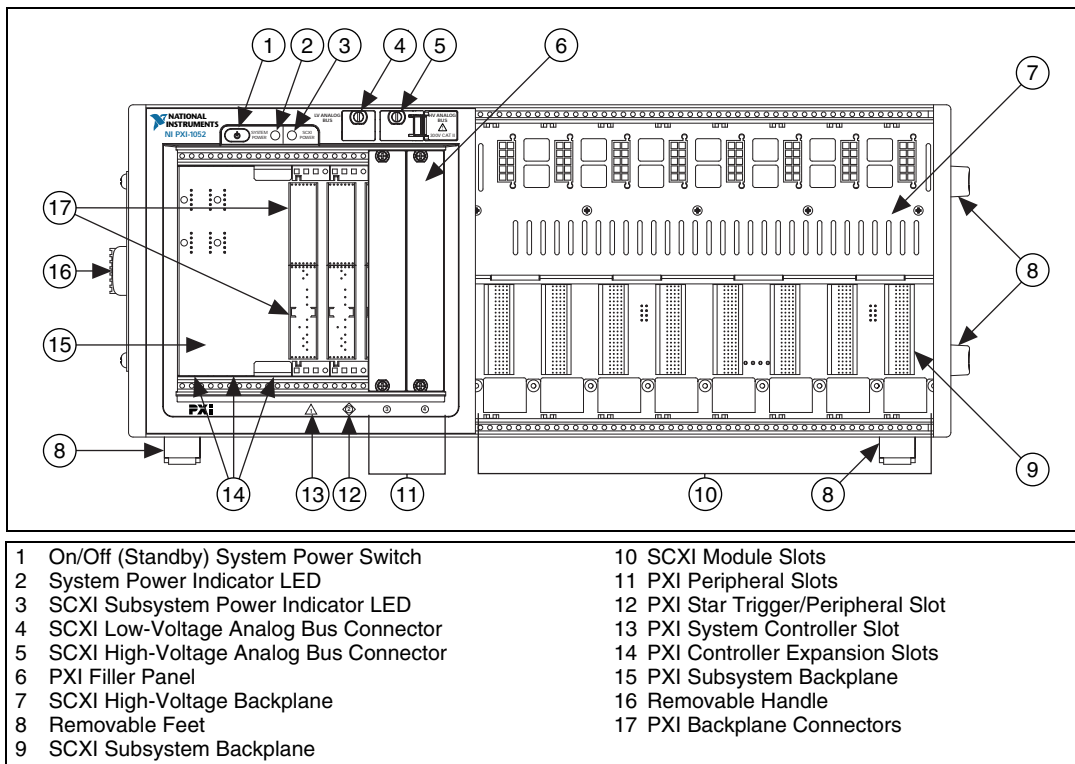

**Figure 1-1.** Front View of the PXI-1052 Chassis

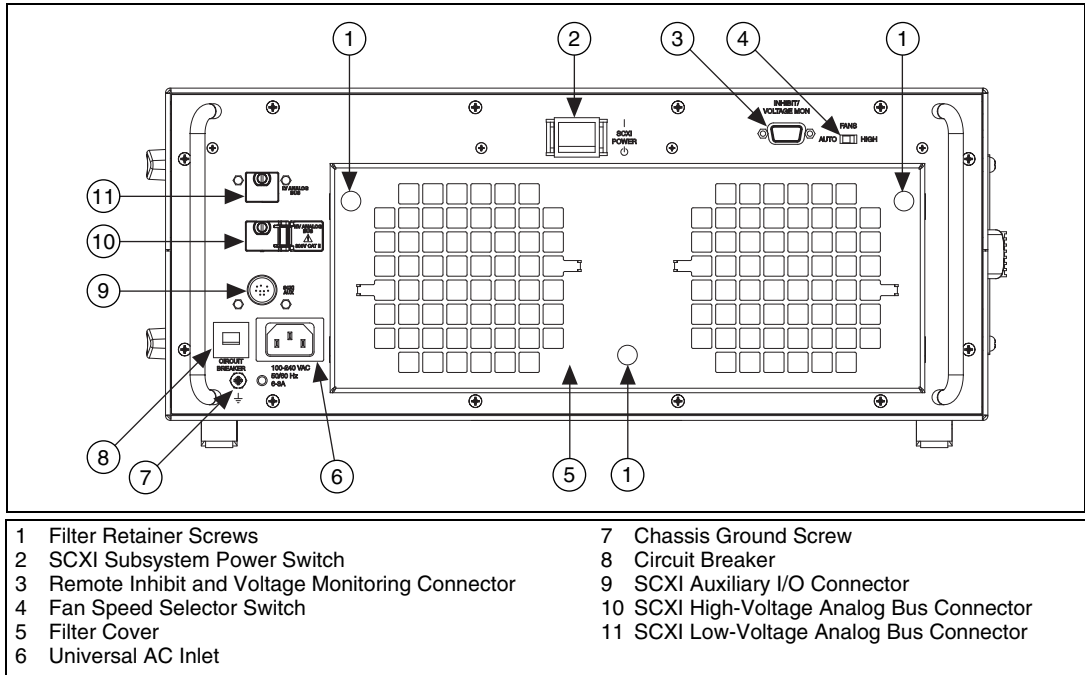

Figure 1-2. Rear View of the PXI-1052 Chassis

## Optional Equipment

Contact NI to order the following options for the PXI-1052 chassis.

- EMC filler panel kits for PXI
- Filler panel kits for SCXI
- Front and rear rack-mount kits for mounting the PXI-1052 chassis into a 19 in. instrument cabinet
- PXI slot blocker kits for improved thermal performance when all slots are not used

## PXI-1052 Backplane Overview

This section gives a basic hardware overview of the PXI-1052 backplane, with interoperability information for the PXI-1052 with CompactPCI, and general information about the local bus, including system controller slot, the star trigger slot, and the peripheral slots.

## Interoperability with CompactPCI

The PXI-1052 backplane is interoperable with 5 V and universal PXI-compatible products and standard CompactPCI products. This is an important feature because some PXI user systems can require components that do not implement PXI-specific features. For example, you may want to use a standard CompactPCI network interface card in a PXI chassis.

The signals on the backplane P1 connectors meet the requirements of the CompactPCI specification for both peripheral and system modules. Refer to Appendix B, *Pinouts*, for pinout information.

The PXI-specific signals are on the backplane P2 connectors and are found only on those signal lines reserved or not used in the CompactPCI 64-bit specification. Therefore, all modules that meet the requirements of the CompactPCI 64-bit specification function in the PXI-1052. Refer to Appendix B, *Pinouts*, for pinout information.

The PXI-1052 backplane has +5 V V(I/O). Refer to the *CompactPCI Specification PICMG 2.0 R3.0* for details regarding V(I/O).

## System Controller Slot

The system controller slot is Slot 1 of the chassis as defined by the PXI specification. There are three controller expansion slots to the left of Slot 1 for system controller modules that are wider than one slot. This prevents the controller from using peripheral slots.

## Star Trigger Slot

Slot 2 is the star trigger slot. This slot has dedicated equal-length trigger lines between Slot 2 and peripheral Slots 3 and 4 (refer to Figure 1-3). Slot 2 is intended for modules with star trigger functionality that can provide individual triggers to all other peripheral modules. However, if you do not require advanced trigger functionality, you can install any standard peripheral module in this slot.

You also can use the star trigger slot to provide a PXI\_CLK10 signal to the backplane. For more information regarding PXI\_CLK10, refer to the *System Reference Clock* section.

## Peripheral Slots

There are three peripheral slots including the star trigger slot.

## Local Bus

The PXI backplane local bus is a daisy-chained bus that connects each peripheral slot with adjacent peripheral slots to the left and right as shown in Figure 1-3. For example, the Slot 2 right local bus connects to the Slot 3 left local bus, and so on.

The left local bus signal lines on Slot 2 are used for the star trigger and do not connect to Slot 1. The right local bus signal lines on Slot 4 are used for SCXI communication.

Each local bus is 13 lines wide and can pass analog signals up to 42 V between cards or provide a high-speed TTL side-band digital communication path that does not reduce the PXI bus bandwidth.

Initialization software uses the configuration information specific to adjacent peripheral modules to evaluate local bus compatibility.

## SCXI Control Slot

Slot 4 of the PXI backplane has connections for a PXI peripheral module such as an NI PXI DAQ module, an NI PXI DMM module, or an NI-Switch controller module to control the SCXI subsystem. These connections use the available local bus right pins (PXI\_LBR0:12). The SCXI connection passes communication, timing, and low-voltage analog bus signals between the SCXI subsystem and the PXI module in Slot 4.



**Note** For more information about the local bus right pins, refer to the *PXI Specification, Revision 2.0*.

## Trigger Bus

All slots on each PXI bus segment share eight PXI trigger lines. You can use these trigger lines in a variety of ways. For example, you can use triggers to synchronize the operation of several different PXI peripheral modules. In other applications, one module located in Slot 2 can control carefully timed sequences of operations performed on other modules in the system. Modules can pass triggers to one another, allowing precisely timed responses to asynchronous external events the system is monitoring or controlling.

## System Reference Clock

The PXI-1052 supplies the PXI 10 MHz system clock signal (PXI\_CLK10) independently to each peripheral slot. An independent buffer (having a source impedance matched to the backplane and a skew of less than 500 ps between slots) drives the clock signal to each peripheral slot. You can use this common reference clock signal to synchronize multiple modules in a measurement or control system. You can drive PXI\_CLK10 from an external source through the PXI\_CLK10\_IN pin on the P2 connector of the star trigger slot. Refer to Table B-4, *P2 (J2) Connector Pinout for the Star Trigger Slot*. Sourcing an external clock on this pin automatically overrides the 10 MHz source of the backplane. Once the transition has been made, reset the chassis to restore it to the initial state.

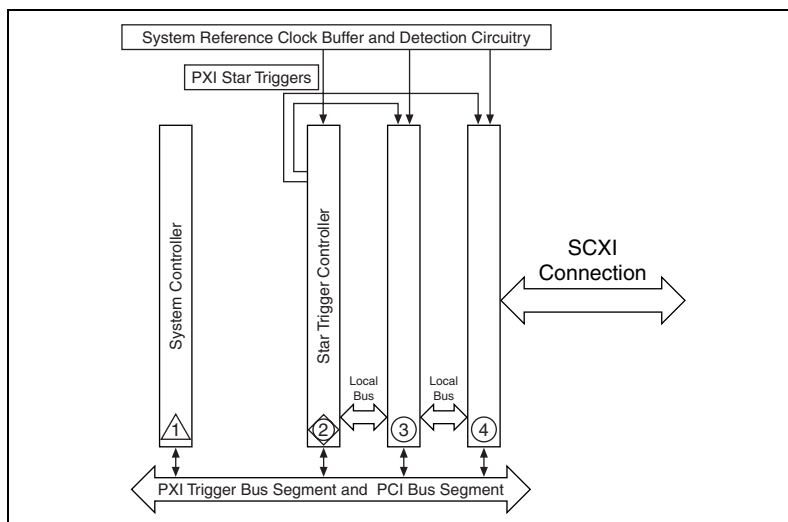

Figure 1-3. PXI Star Trigger and Local Bus Routing

## SCXI Subsystem Overview

To use the SCXI subsystem of the PXI-1052, you *must* have a DAQ/DMM/Switch controller module in Slot 4 of the PXI subsystem to control and/or acquire data from the SCXI modules.



**Note** The chassis address of the SCXI subsystem is hard-wired as 0.

---

# Installation and Configuration

This chapter describes how to install, configure, and use the PXI-1052 chassis.

Before connecting the chassis to a power source, read this chapter and the *Read Me First: Safety and Radio-Frequency Interference* document included with the chassis.

---

## Safety Information



**Caution** Before undertaking any troubleshooting, maintenance, or exploratory procedure, carefully read the following caution notices.

This equipment contains voltage hazardous to human life and safety, and is capable of inflicting personal injury.

- **Chassis Grounding**—The PXI-1052 requires a connection from the earth safety ground to the PXI-1052 chassis ground. The earth safety ground must be connected during use of this equipment to minimize shock hazards. Refer to the [Connecting Safety Ground](#) section for instructions on connecting safety ground.
- **Live Circuits**—Operating personnel and service personnel *must* not remove protective covers when operating or servicing the PXI-1052. Adjustments and service to internal components must be undertaken by qualified service technicians. During service of this product, the main connector to the earth wiring must be disconnected. Dangerous voltages may be present under certain conditions; use extreme caution.
- **Explosive Atmosphere**—Do *not* operate the chassis in conditions where flammable gases are present. Under such conditions this equipment is unsafe and can ignite the gases or gas fumes.
- **Part Replacement**—Only service this equipment with parts that are exact replacements, both electrically and mechanically. Contact NI for replacement part information. Installation of parts with those that are not direct replacements may cause harm to personnel operating the chassis. Furthermore, damage or fire may occur if replacement parts are unsuitable.

- **Modification**—Do *not* modify any part of the chassis from its original condition. Unsuitable modifications may result in safety hazards.

## Chassis Cooling Considerations

The PXI-1052 is designed to operate on a bench or in an instrument rack. Determine how you want to use the PXI-1052 and follow the appropriate installation instructions.

### Providing Adequate Clearance

Openings in the top and along both sides of the chassis facilitate power supply and module cooling. Air enters through filters and fan inlets in the lower rear of the chassis and exits through the upper sections on both sides and through the top, as shown in Figure 2-1. Provide adequate ventilation space around the PXI-1052 on a bench top or in an instrument rack so that the fans (air inlets) and the air outlet apertures along both sides and the top of the chassis are not obstructed. Keep other equipment a minimum of 76.2 mm (3 in.) away from the air inlets on the rear of the chassis.

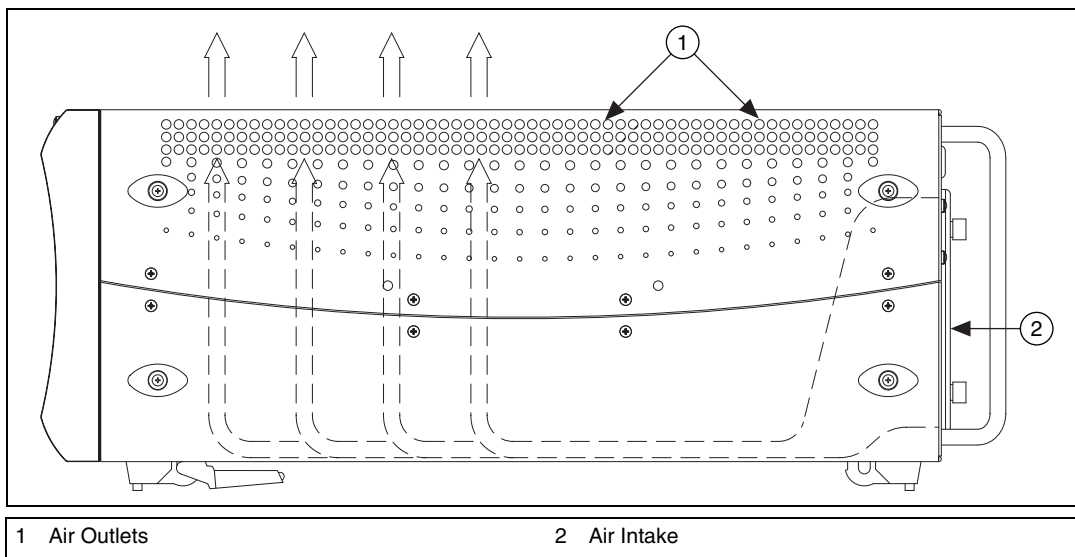

**Figure 2-1.** PXI-1052 Chassis Airflow Side View

When rack mounting the PXI-1052, provide at least 44.5 mm (1.75 in.) clearance above and on the sides of the unit for adequate venting. High-power applications can require additional clearance.



**Tip** Install the chassis so that you can access the rear panel easily. This simplifies cleaning or replacing the air filters.

## Setting Fan Speed

The fan-speed selector switch is on the rear panel of the PXI-1052. Refer to Figure 1-2, *Rear View of the PXI-1052 Chassis*, to locate the fan-speed selector switch. Select HIGH for maximum cooling performance (recommended) or AUTO for quieter operation. The fan speed is determined by chassis intake air temperature when set to AUTO.

## Installing Filler Panels

To improve module cooling performance, install optional PXI filler panels in unused slots. Secure the panels with the captive mounting thumbscrews provided. You can obtain these panels through NI.

## Installing Slot Blockers

You can improve the cooling performance of the chassis by installing optional PXI slot blockers. Visit [ni.com/support](http://ni.com/support) to read the NI KnowledgeBase article 2S4928ON, *PXI Slot Blockers and Improved PXI System Cooling Performance*, for more details.

## Rack Mounting

---

Rack-mount applications require one of the optional rack-mount kits available from NI. Refer to Figure A-3, *PXI-1052 Rack Mount Kit Components*, and the instructions supplied with the rack-mount kits to install the PXI-1052 in an instrument rack.



**Note** You may want to remove the feet from the PXI-1052 when rack mounting. To do so, remove the screws holding the feet in place.

## Connecting Safety Ground

---



**Caution** The PXI-1052 chassis is designed with a three-position NEMA 5-15 style plug for the United States that connects the ground line to the chassis ground. To minimize shock hazard, make sure the electrical power outlet you use to power the chassis has an appropriate earth safety ground.

If the power outlet does not have an appropriate ground connection, you must connect the premise safety ground to the chassis grounding screw located on the rear panel. Refer to Figure 1-2, [Rear View of the PXI-1052 Chassis](#), to locate the chassis grounding screw. Complete the following steps to connect the safety ground.

1. Connect a 16 AWG (1.3 mm) wire to the chassis grounding screw using a grounding lug. The wire must have green insulation with a yellow stripe or must be noninsulated (bare).
2. Attach the opposite end of the wire to permanent earth ground using toothed washers or a toothed lug.

## Connecting to Power Source

---



**Caution** Do *not* install modules prior to performing the following power-on test.

Attach input power through the rear AC inlet using the appropriate AC power cable supplied. Refer to Figure 1-2, [Rear View of the PXI-1052 Chassis](#), to locate the AC inlet.



**Caution** To completely remove power, you *must* disconnect the AC power cable.

The power switch allows you to power on the chassis or place it in standby mode. Push the power switch to the On (recessed) position (if not already on). Observe that all fans become operational and the system power switch LED is a steady green.

The system power indicator LED should be lit indicating that system power is available to both the PXI and SCXI subsystems. The PXI subsystem remains powered as long as the system power is on. However, you can control the SCXI subsystem using the power switch on the rear panel.

# Power Switch LED Indicators

---

The chassis has two LEDs next to the power switch. The system power LED indicates the power status for the chassis. The SCXI power LED, when lit, indicates that power is available to the SCXI subsystem. The system power LED indicates one of three different conditions.

1. If the system power LED is steady green (not flashing), the chassis is powered on and operating normally.



**Caution** Operating the PXI system outside of the specified temperature range can result in loss of data, reduction of chassis life, or damage to equipment.

2. If the system power LED is flashing green, the air-intake temperature has exceeded the chassis operating range. Complete the following steps:
  - a. Power off the system.
  - b. Unplug the AC power cable.
  - c. Inspect the chassis for ventilation obstructions and clear them.
  - d. If the condition persists, contact NI using the information in the front of this manual.



**Caution** Power supply output voltages out of regulation can result in equipment malfunction, incorrect data, or failure of system to boot.

3. If the system power LED is flashing red, the PXI power supply outputs are not within voltage regulation requirements. Complete the following steps:
  - a. Power off the system.
  - b. Unplug the AC power cable.
  - c. Inspect the chassis for physical damage.
  - d. Verify that there is no issue with the AC supply feed to the PXI-1052 chassis.
  - e. If the condition persists, contact NI using the information in the front of this manual.

## Installing a PXI Controller

This section contains general instructions for installing a PXI controller in the PXI-1052 chassis. Refer to your PXI controller user manual for specific instructions and cautions. Complete the following steps to install a controller.

1. Plug in the PXI chassis before installing the controller. The power cord grounds the chassis and protects it from electrical damage while you install the controller. Make sure the chassis power switch is in the Off (Standby) position.



**Caution** To protect yourself and the chassis from electrical hazards, leave the chassis off until you complete the controller installation.

2. Install the controller into the system controller slot (Slot 1, indicated by the red card guides) by completing the following steps:
  - a. Place the controller edges into the front controller guides (top and bottom).
  - b. Slide the controller to the rear of the chassis, making sure that the injector/ejector handle is pushed down as shown in Figure 2-2.

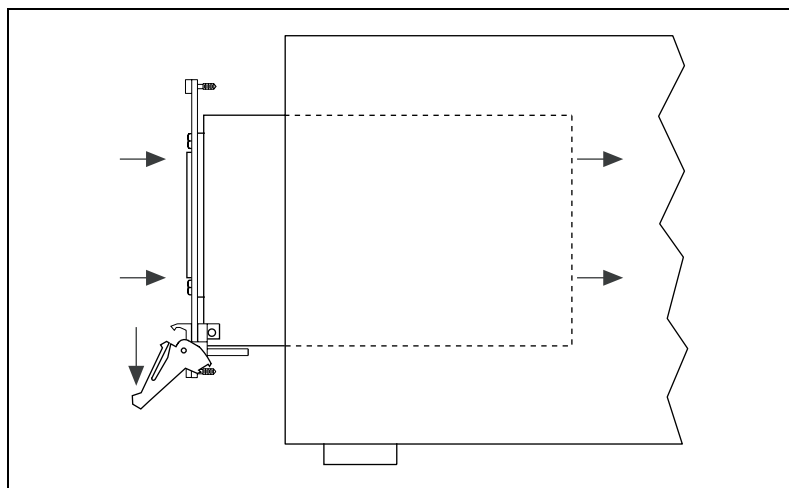

**Figure 2-2.** Injector/Ejector Handle Position during Controller or Peripheral Module Insertion

3. When you begin to feel resistance, pull up on the injector/ejector handle to inject the controller fully into the chassis frame. Secure the controller front panel to the chassis using the four controller front-panel mounting thumbscrews.
4. Connect the keyboard, mouse, and monitor to the appropriate connectors. Connect devices to ports as required by your system configuration.
5. Power on the chassis. Verify that the controller boots. If the controller does not boot, refer to the controller user manual.

Figure 2-3 shows a PXI controller installed in the system controller slot of a PXI-1052 chassis. You can place CompactPCI or PXI modules in any other slots.

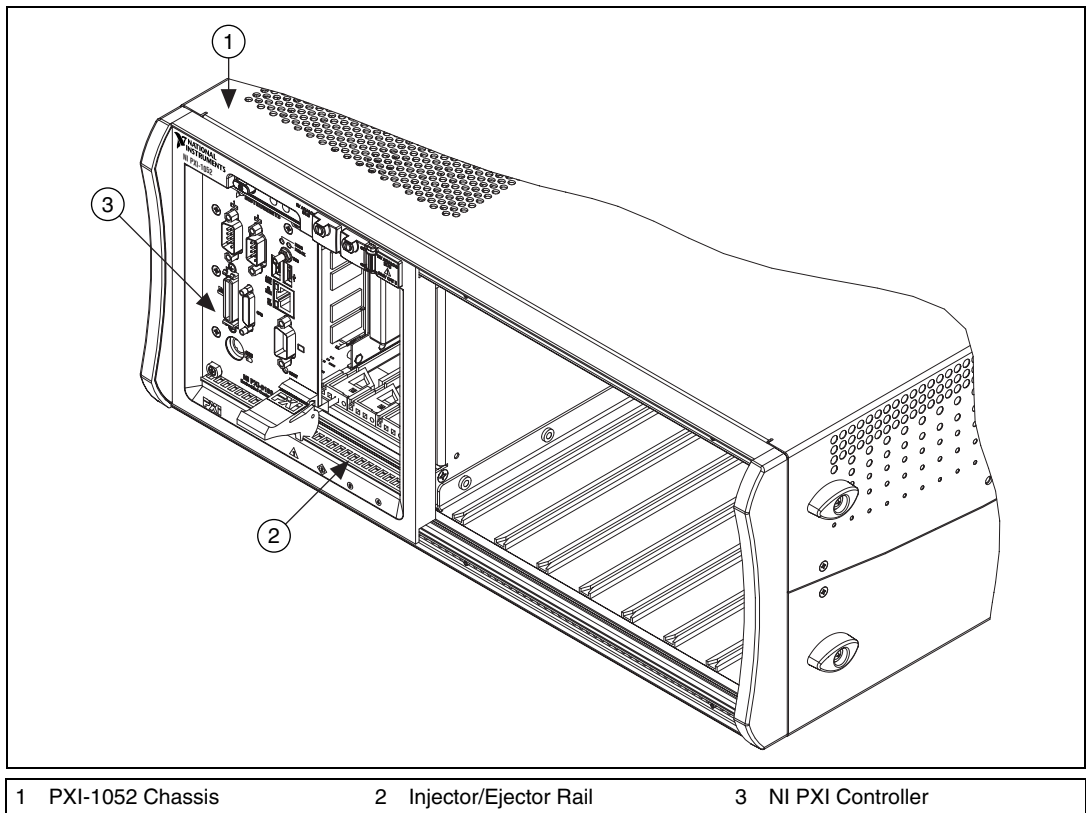

**Figure 2-3.** NI PXI Controller Installed in a PXI-1052 Chassis

## Installing PXI Modules

---



**Note** Remove any rubber thread protectors from the PXI module mounting thumbscrews before you install the module.

Complete the following steps to install a module.

1. Make sure the power switch is in the Off position (NI LEDs on the front of the chassis are not lit).
2. Install a module into a chassis slot by completing the following steps:
  - a. Place the module card edges into the front module guides (top and bottom). Refer to Figure 2-4.
  - b. Slide the module to the rear of the chassis, making sure that the injector/ejector handle is pushed down as shown in Figure 2-2.
3. When you begin to feel resistance, pull up on the injector/ejector handle to fully inject the module into the chassis frame. Secure the module front panel to the chassis using the two module front-panel mounting thumbscrews.

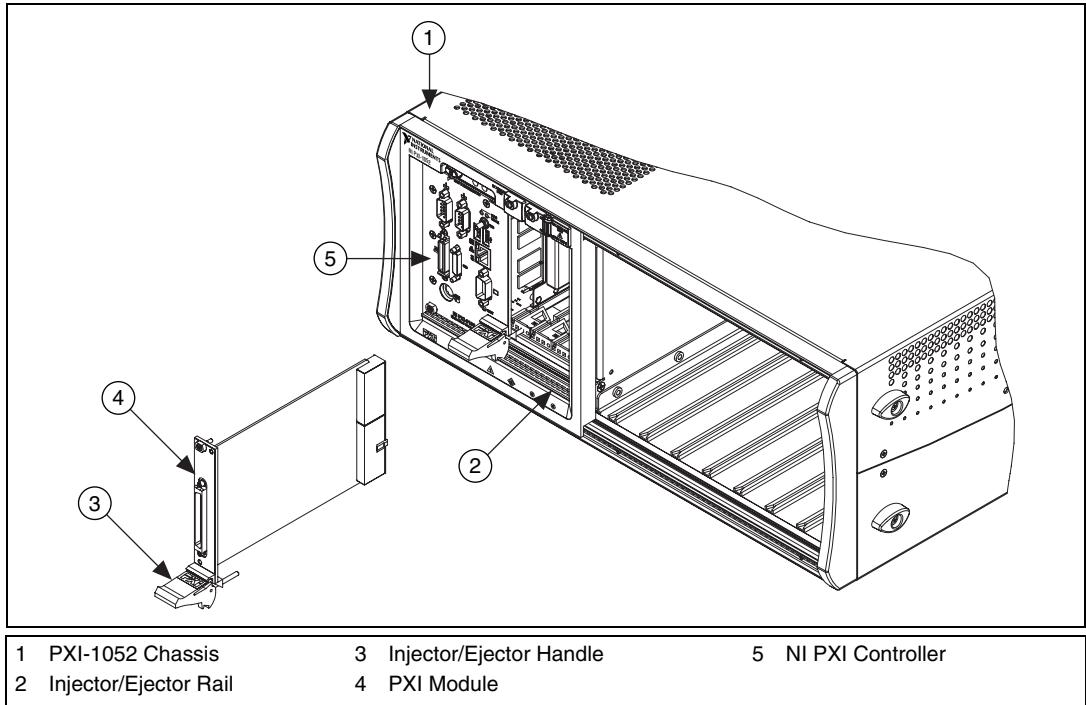

**Figure 2-4.** Installing PXI or CompactPCI Modules

## Installing Optional PXI Filler Panels

The PXI filler panels protect the inside of the PXI subsystem by preventing unwanted material from entering the PXI-1052 chassis and damaging modules or forming conductive paths that can degrade performance. Install all PXI modules first, then install PXI filler panels in any unused PXI slots.

Filler panels are the full height of a slot. Complete the following steps to install PXI filler panels.

1. Place the filler panel with the captive thumbscrews in front of an unused PXI slot. Line up the thumbscrews with the threaded strip holes.
2. Using a flathead screwdriver, screw the two captive thumbscrews into the threaded strip holes.

## Installing SCXI Modules

---



**Notes** Remove any rubber thread protectors from the SCXI module mounting thumbscrews before you install the module.

Refer to the SCXI module and terminal block documentation for specific instructions related to configuration and signal connections.

Complete the following steps to install an SCXI module.

1. Power off the PXI/SCXI chassis using the switch shown in Figure 1-1, *Front View of the PXI-1052 Chassis*. To make sure that the chassis power is off, verify that the LEDs are not lit.
2. Insert the module into the module guide rails and slide the module to the back of the chassis. Do *not* force the module into place.
3. Tighten the captive thumbscrews on the front panel of the module to secure it in the SCXI subsystem.

### Installing Optional SCXI-1360 Filler Panels

The SCXI-1360 filler panels protect the inside of the SCXI subsystem by preventing unwanted material from entering the PXI-1052 chassis and damaging modules or forming conductive paths that degrade performance. Install all SCXI modules first, then install SCXI filler panels in any unused SCXI slots.

Filler panels are the full height (4U) of an SCXI slot. Complete the following steps to install SCXI-1360 filler panels.

1. Place the filler panel with the captive thumbscrews in front of an unused SCXI slot. Line up the thumbscrews with the threaded strip holes.
2. Using a flathead screwdriver, screw the two captive thumbscrews into the threaded strip holes.

## PXI System Configuration with MAX

---

Configuration of the PXI system is handled through Measurement & Automation Explorer (MAX), included on the NI Driver CD packaged with NI PXI controllers and devices. MAX creates the `pxisys.ini` file, which defines the layout and parameters of your PXI system. After installing the

software on the NI Driver CD, the MAX icon is present on the desktop. The configuration steps for single- or multiple-chassis systems are the same, and these instructions are valid for either embedded controller-based systems or systems controlled through interface with an external PC.

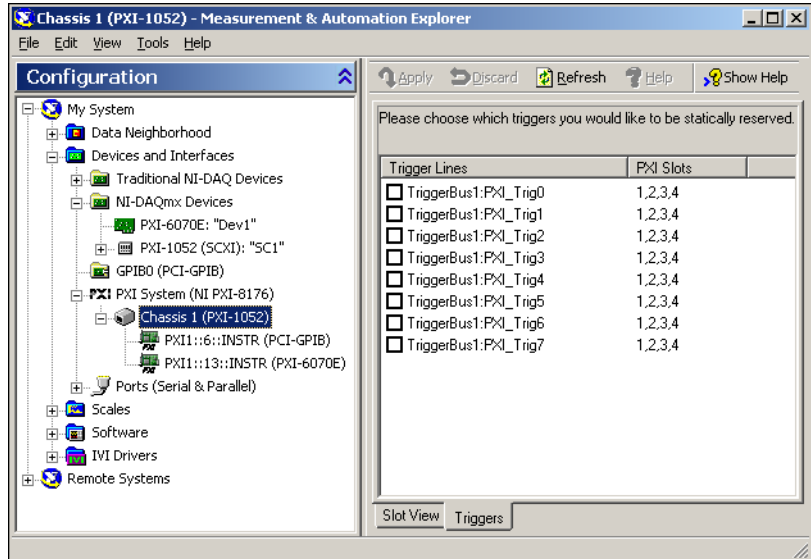

Figure 2-5. Multichassis Configuration in MAX

## Basic PXI System Configuration

1. Launch MAX.
2. In the **Configuration** tree, click the **Devices and Interfaces** branch to expand it.
3. If the PXI system controller is not configured, it is labeled **PXI System (Unidentified)**. Right-click this entry to display the context menu and select the appropriate chassis model from the **Identify As** submenu.



**Note** If your chassis model is not listed, select **Other** from the list, and then select the appropriate chassis.ini file from the *NI PXI Resource CD* included in your kit.

4. Click the **PXI System** controller entry. The chassis (or multiple chassis, in a multichassis configuration) is listed below it. Identify each chassis by right-clicking its entry and selecting the appropriate chassis model through the **Identify As** submenu. Further expanding the **PXI System** branch shows all of the devices in the system that NI-VISA can recognize. Once the controller and all of the chassis are identified, MAX will generate the required `pxisys.ini` file.
5. Apply the chassis number labels, shown in Figure 2-6, included with the kit to each chassis in the PXI system, and write in the chassis number accordingly in the white space.



**Figure 2-6.** Chassis Number Label

## Trigger Configuration in MAX

Each chassis has one or more trigger buses, each with eight lines numbered 0 through 7 that you can reserve and route statically or dynamically. Static reservation *pre-allocates* a trigger line to prevent its configuration by a user program. Dynamic reservation/routing/deallocation is automatic within a user program based upon NI APIs such as NI-DAQmx. You can implement static reservation of trigger lines in MAX through the **Triggers** tab. Reserved trigger lines are not used by PXI modules dynamically configured by programs such as NI-DAQmx. This prevents the instruments from double-driving the trigger lines, possibly damaging devices in the chassis.

Complete the following steps to reserve these trigger lines in MAX.

1. In the **Configuration** tree, click the PXI chassis branch you want to configure.
2. Click the **Triggers** tab at the bottom of the right-hand pane.
3. Select the trigger lines you want to statically reserve.
4. Click the **Apply** button.

## Using System Configuration and Initialization Files

The PXI specification allows many combinations of PXI chassis and system modules. To assist system integrators, the manufacturers of PXI chassis and system modules must document the capabilities of their products. The minimum documentation requirements are contained in `.ini` files, which consist of ASCII text. System integrators, configuration utilities, and device drivers can use these `.ini` files.

The capability documentation for the PXI-1052 chassis is contained in the `chassis.ini` file on the software media that comes with the chassis. The information in this file is combined with information about the system controller to create a single system initialization file called `pxisys.ini` (PXI System Initialization). The system controller manufacturer either provides a `pxisys.ini` file for the particular chassis model that contains the system controller or provides a utility that can read an arbitrary `chassis.ini` file and generate the corresponding `pxisys.ini` file. NI system controllers use MAX to generate the `pxisys.ini` file from the `chassis.ini` file.

Device drivers and other utility software read the `pxisys.ini` file to obtain system information. Device drivers should not need to directly read the `chassis.ini` file. For detailed information regarding initialization files, refer to the PXI specification at [www.pxisa.org](http://www.pxisa.org).

## SCXI Configuration with MAX

---

To use the SCXI capabilities of the PXI-1052 chassis, you must configure the SCXI portion of the chassis in MAX.



**Note** Refer to the Hardware Installation Wizard at [ni.com/support/install](http://ni.com/support/install) for SCXI configuration instructions with RT Series products. Select **Hardware Configuration** and click **Real-Time Configuration Wizard**.

1. Make sure the SCXI backplane is powered on, since it is powered separately from the PXI backplane. The SCXI chassis power switch is located on the rear panel of the PXI-1052 chassis.
2. Double-click the **Measurement & Automation** icon on the desktop to launch MAX.
3. Right-click **Devices and Interfaces** and select **Create New**.
4. Select the **PXI-1052 (SCXI)** chassis under **NI-DAQmx Device» NI-DAQmx SCXI Chassis**.

5. Click **Finish**. A configuration window opens. Refer to the *DAQ Quick Start Guide* included with your kit for more information.

There is an alternative way to add an SCXI chassis. Right-click **Devices & Interfaces** » **NI-DAQmx Devices** and select **Create New NI-DAQmx Device**. Select **NI-DAQmx SCXI Chassis** and choose the **PXI-1052 (SCXI)** chassis.

## Configure the Chassis

Complete the following steps to configure the chassis.

1. Select whether or not to auto-detect SCXI modules as shown in Figure 2-7. If you do not auto-detect modules, MAX disables Communicating SCXI Module Slot.

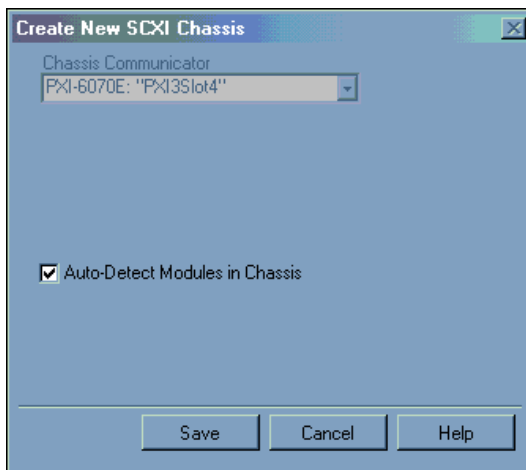

**Figure 2-7.** Auto-Detection of Modules in SCXI Chassis

2. Click **Save**.
3. The SCXI Chassis Configuration window opens. The **Modules** tab is selected by default. If you did not auto-detect modules, select an SCXI module from the **Modules** listbox. Be sure to locate the module in the correct slot.
4. MAX provides a default name for the Device Name field. To change the name, click in the field and enter a unique alphanumeric ID for the SCXI module.
5. If you are using a connected accessory, select it from **Accessory**.

6. Click **Details** for more configuration options. Refer to the *Configure the SCXI Modules* section for more information.
7. If you need to change any chassis settings, click the **Chassis** tab.
8. Click **OK** to accept and save the settings for this chassis.



**Note** You cannot save the chassis configuration until you finish entering module information. A message at the top of the SCXI Chassis Configuration window alerts you of the status of the configuration. You cannot save if an error appears in the message box. If a warning appears in the message box, you can save the configuration, although NI recommends fixing the source of the warning before saving.

## Configure the SCXI Modules

Complete the following steps to configure the modules. You can skip this section if you are using a single MIO device with the SCXI system in multiplexed mode.

1. Select the chassis from **Devices and Interfaces»NI-DAQmx Devices**.
2. Right-click the module and choose **Properties**.



**Note** You also can access module properties by selecting the **Modules** tab of the SCXI Chassis Configuration window and clicking **Details**.

3. Some SCXI modules have jumper-selectable settings. If you are configuring such a module, click the **Jumpers** tab and enter the hardware-selected settings.
4. Click the **Accessory** tab.
5. To change the accessory selected during chassis configuration, select a module accessory from the **Accessory** drop-down listbox.
6. Click **Configure** to edit accessory settings. Not all accessories have settings. Refer to the accessory documentation for more information.
7. If you are using an AI module, click the **Cabling** tab.



**Note** You need not adjust the information in the cabling tab if you are using standard multiplexed mode operation. If you are using parallel mode operation, multichassis configuration, or another special configuration, adjust the options on the **Cabling** tab.

8. Select the DAQ device connected to the SCXI module from the **Which device connects to this module?** drop-down listbox. In most cases, the device selected here and the module digitizer are the same.
9. Select a DAQ device from the **Module Digitizer** drop-down listbox. The device can be different from the device selected from the **Which device connects to this module?** listbox.
10. If operating in parallel mode, click **Parallel Mode**.
11. If the module is installed in a daisy-chained chassis, select an index number from the **Multichassis Daisy-Chain Index** drop-down listbox. The listbox appears only if two or more chassis have been added and saved.
12. Click **OK**.

For information about software-configurable properties of the module, refer to the *Measurement & Automation Explorer Help for Traditional NI-DAQ* or the *Measurement & Automation Explorer Help for NI-DAQmx*. To access this help in MAX, select **Help»Help Topics»Traditional NI-DAQ** or **Help»Help Topics»NI-DAQmx**.

## Test the Chassis

Complete the following steps to verify that MAX recognizes the SCXI chassis correctly.

1. Right-click the chassis name in the NI-DAQ API you want to test under **Devices and Interfaces**.
2. Select **Test**. If you are using NI-DAQmx and the test fails, a message explains the failure.

## Configure Channels and Tasks

A *physical channel* is a terminal or pin at which you can measure or generate an analog or digital signal. A *virtual channel* is a collection of settings that can include a name, a physical channel, input terminal connections, the type of measurement or generation, and scaling information. In Traditional NI-DAQ and earlier versions, configuring virtual channels is an optional way to record which channels are used for different measurements. In NI-DAQmx, virtual channels are integral to every measurement.

In Traditional NI-DAQ, you configure virtual channels using MAX. In NI-DAQmx, you can configure virtual channels with the DAQ Assistant, which you can open from MAX or your application software. You also can configure virtual channels with the NI-DAQmx API in your application program.

A *task*, an important new concept for NI-DAQmx, is a collection of one or more virtual channels with timing, triggering, and other properties. Conceptually, a task represents a measurement or generation you want to perform. You can set up and save all of the configuration information in a task and use the task in an application.

In NI-DAQmx, you can configure virtual channels as part of a task or separate from a task. Virtual channels created inside a task are *local channels*. Virtual channels defined outside a task are *global channels*. You can create global channels in MAX or in your application software and then save them in MAX. You can use global channels in any application or add them to a number of different tasks. If you modify a global channel, the change affects all tasks in which you reference that global channel. In most cases, it is simpler to use local channels.

## Configure a Task in NI-DAQmx

Configure tasks with the DAQ Assistant. You must have version 7.0 or later of an NI application software package to create tasks and channels with the DAQ Assistant.

- In MAX, right-click **Data Neighborhood** and select **Create New**. In the **Create New** window, select **NI-DAQmx Task** and click **Next**.
- You also can open the DAQ Assistant directly from within NI application software.
  - In LabVIEW, there are several ways to open the DAQ Assistant.
    - Drop the DAQ Assistant Express VI from the Express Input palette, as described in the *Getting Started with LabVIEW* document.
    - You also can use the DAQmx Task Name control to open the DAQ Assistant. Right-click the control and select **New Task**. The *Taking an NI-DAQmx Measurement in LabVIEW* tutorial has step-by-step instructions on how to create a task from the DAQmx Task Name control and generate code for the task. In LabVIEW, select **Help»Taking an NI-DAQmx Measurement** to open the tutorial.

- In LabWindows™/CVI™, select **Tools»Create/Edit DAQmx Tasks**.
- In Measurement Studio, open Visual Studio .NET and select **Project»Add New Item** to open the Add New Item dialog box. In the Categories pane, select **Measurement Studio»Assistants**. In the Templates pane, select **DAQmx Task Class**.

Follow the online instructions to create a new task.

1. Select an I/O type, such as analog input.
2. Select the measurement or generation to perform.
3. Choose the sensor to use, if applicable.
4. Select the channels to add to the task. You can add global channels to the task or select physical channels from which to create local channels in the task.
5. Configure measurement-specific settings, timing, and triggering, if necessary.
6. Save the task.
  - If you opened the DAQ Assistant from LabVIEW or LabWindows/CVI, click **OK**.
  - If you opened the DAQ Assistant from Measurement Studio, select **File»Save**.

You now can use the task in an application. Refer to the *DAQ Assistant Help* or application software documentation for more information about using a task or generating code.

## Configure Global Channels for NI-DAQmx

Configure global channels with the DAQ Assistant when you use NI-DAQmx.

- In MAX, right-click **Data Neighborhood** and select **Create New**. In the **Create New** window, select **NI-DAQmx Global Channel** and click **Next**.
- You also can open the DAQ Assistant directly from within LabVIEW 7.0 or later, LabWindows/CVI 7.0 or later, or Measurement Studio 7.0 or later.
  - In LabVIEW, use the DAQmx Global Channel control to open the DAQ Assistant. Right-click the control and select **New Channel (DAQ Assistant)**.

- In LabWindows/CVI or Measurement Studio, you first must create a task as previously described. In the DAQ Assistant, click **Add Existing DAQmx Global Channels** to add global channels to your task.

The DAQ Assistant opens. Follow the online instructions to create a new global channel.

1. Select an I/O type, such as analog input.
2. Select the measurement or generation to perform.
3. Choose the sensor to use, if applicable.
4. Select the physical channels to use.
5. Configure measurement-specific settings.
6. Save the task.
  - If you opened the DAQ Assistant from LabVIEW or LabWindows/CVI, click **OK**.
  - If you opened the DAQ Assistant from Measurement Studio, select **File»Save**.

You now can use the global channel in an application or add the global channel to a task. Refer to the *DAQ Assistant Help* or application software documentation for more information about using a channel or generating code.



**Note** For more information about the NI-DAQmx application programming interface (API), refer to the *DAQ Quick Start Guide*.

## Remote Voltage Monitoring and Control

---

The PXI-1052 chassis supports remote CompactPCI voltage monitoring and inhibiting through a male 9-pin D-Sub connector located on the rear panel. Table 2-1 shows the pinout of the 9-pin D-Sub connector.

**Table 2-1.** Remote Inhibit and Voltage Monitoring Connector Pinout

D-Sub Pin	Signal
1	Logic Ground
2	+5 VDC
3	Reserved
4	+3.3 VDC
5	Inhibit (Active Low)
6	+12 VDC
7	Reserved
8	-12 VDC
9	Logic Ground

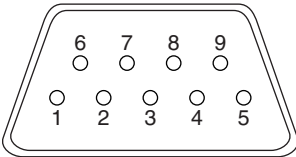
You can use the Inhibit signal (active low) to power off the chassis. To remotely power off the chassis, connect the Inhibit pin (pin 5) to a Logic Ground pin (pins 1 or 9). As long as this connection exists, the chassis remains off (standby). When you remove this connection, the chassis powers on.



**Note** For the Inhibit signal to control the On/Off (Standby) state of the chassis, the front power switch must be in the On (recessed) position.



**Cautions** When connecting digital voltmeter probes to the rear 9-pin D-Sub connector, be careful not to short the probe leads together. Doing so can damage the power supply.

Use the rear-panel 9-pin D-Sub connector to check voltages only. Do *not* use the connector to supply power to external devices, or you can damage the equipment in the chassis.

You can use a digital voltmeter to ensure all CompactPCI voltage levels in the PXI-1052 are within the allowable limits. Referring to Table 2-2, connect one lead of the voltmeter to a supply pin on the remote power monitoring connector (9-pin D-Sub) on the rear panel. Refer to Table 2-1 for a pinout diagram of the remote voltage monitoring connector. Connect the reference lead of the voltmeter to one of the ground pins. Compare each voltage reading to the values listed in Table 2-2.

**Table 2-2.** Power Supply Voltages at Voltage Monitoring Connector

Pin	Supply	Acceptable Voltage Range
2	+5 V	4.75 to 5.25 V
4	+3.3 V	3.135 to 3.465 V
6	+12 V	11.4 to 12.6 V
8	-12 V	-12.6 to -11.4 V
1, 9	Logic Ground	0 V

If the voltages fall within the specified ranges, the chassis complies with the CompactPCI voltage-limit specifications.

---

# Maintenance

This chapter describes basic maintenance procedures you can perform on the PXI-1052 chassis.



**Caution** Disconnect the power cable prior to servicing the PXI-1052 chassis.

---

## Service Interval



**Note** Depending on the amount of use and ambient dust levels in the operating environment, the filters may require more frequent cleaning.

Clean the chassis fan filters at a maximum interval of six months.

Clean dust from the chassis exterior (and interior) as needed, based on the operating environment. Periodic cleaning increases reliability.

---

## Preparation

The information in this chapter is designed for use by qualified service personnel. Read the *Read Me First: Safety and Radio-Frequency Interference* document included with the kit before attempting any procedures in this chapter.



**Caution** Many components within the chassis are susceptible to static discharge damage. Service the chassis only in a static-free environment. Observe standard handling precautions for static-sensitive devices while servicing the chassis. Always wear a grounded wrist strap, or equivalent, while servicing the chassis.

# Cleaning

---



**Caution** Always disconnect the AC power cable before cleaning or servicing the chassis.

Cleaning procedures consist of exterior and interior cleaning of the chassis and cleaning the fan filters. Refer to the module user documentation for information on cleaning individual CompactPCI, SCXI, or PXI modules.

## Interior Cleaning

Use a dry, low-velocity stream of air to clean the interior of the chassis.  
Use a soft-bristle brush for cleaning around components.

## Exterior Cleaning



**Cautions** Avoid getting water inside the chassis during exterior cleaning, especially through the top vents. Use just enough water to dampen the cloth.

Do *not* wash the front- or rear-panel connectors or switches. Cover these components while cleaning the chassis.

Do *not* use harsh chemical cleaning agents; they can damage the chassis. Avoid chemicals that contain benzene, toluene, xylene, acetone, or similar solvents.

Clean the exterior surfaces of the chassis with a dry lint-free cloth or a soft-bristle brush. If any dirt remains, wipe with a cloth moistened with a mild cleaning agent. Remove any soap residue by wiping with a cloth moistened with clear water. Do *not* use abrasive compounds on any part of the chassis.

# Cleaning and Replacing the Fan Filters

---



**Note** Power off the chassis and unplug the AC power cable before cleaning or removing the fan filters.

Dirty fan filters can dramatically reduce the cooling performance of the PXI-1052 chassis. Clean the filters whenever they become visibly dirty. You can remove the chassis air filters from the rear of the chassis easily by removing the filter retainer. To remove the filter retainer, loosen the retainer screws. The filter cover and retainer are shown in Figure 1-2, *Rear View of the PXI-1052 Chassis*.

Clean the fan filters by washing them with a mild cleaning agent and then vacuuming or blowing air through them. Rinse the filters with water and allow them to dry before reinstalling them on the chassis.

You can purchase the same filter media in sheets, and make a filter replacement.

## Resetting the AC Mains Circuit Breaker

---

If the PXI-1052 encounters an over-current condition, the circuit breaker on the rear panel trips to prevent damage to the chassis. Complete the following steps to reset the circuit breaker.

1. Press the front panel power switch to the Off (Standby) position.
2. Disconnect the AC power cable.
3. Depress the circuit breaker to reset it.
4. Reconnect the AC power cable.
5. Press the power switch to the On position.

If the circuit breaker trips again, complete the following steps:

1. Press the front panel power switch to the Off (Standby) position.
2. Disconnect the AC power cable.
3. Remove all modules from the chassis.
4. Complete the procedure described in the *Connecting to Power Source* section of Chapter 2, *Installation and Configuration*. If the system power switch LED is not a steady green, contact NI through the information given in Appendix C, *Technical Support and Professional Services*.

5. Verify that the PXI-1052 can meet the power requirements of the installed CompactPCI, SCXI, or PXI modules. Overloading the chassis can cause the breaker to trip. Refer to Appendix A, [Specifications](#).
6. The over-current condition that caused the circuit breaker to trip can be due to a faulty CompactPCI, SCXI, or PXI module. Refer to the documentation supplied with the modules for troubleshooting information.

---

# Specifications



**Caution** If the PXI-1052 chassis is used in a manner inconsistent with the instructions or specifications listed by NI, the protective features of the chassis may be impaired.

This appendix contains specifications for the PXI-1052 chassis.

## Electrical

### AC Input

Input voltage range.....	100–240 VAC
Operating voltage range <sup>1</sup> .....	90–264 VAC
Input frequency .....	50/60 Hz
Operating frequency range <sup>1</sup> .....	47–63 Hz
Input current rating.....	6–3 A
Over-current protection.....	10 A circuit breaker
Installation Category .....	II
Efficiency .....	70% minimum

---

<sup>1</sup> The operating range is guaranteed by design.

Power disconnect.....The AC power cable provides main power disconnect. Depressing the front-panel power switch controls the internal chassis power supply that provides DC power to the CompactPCI/PXI backplane. You also can use the rear-panel 9-pin D-Sub connector to control the internal chassis power supply.

## DC Output

DC current capacity ( $I_{MP}$ )

Voltage	0–50 °C	50–55 °C
+3.3 V	12 A	12 A
+5 V	17 A	17 A
+12 V	2 A	2 A
–12 V	1 A	1 A
+20 V	1.36 A	1.16 A
–20 V	1.36 A	1.16 A

Maximum ripple and noise (20 MHz bandwidth)

Voltage	Maximum Ripple and Noise
+3.3 V	50 mV <sub>pp</sub>
+12 V	120 mV <sub>pp</sub>
+5 V	50 mV <sub>pp</sub>
–12 V	120 mV <sub>pp</sub>
+20 V	200 mV <sub>pp</sub>
–20 V	200 mV <sub>pp</sub>

Over-current protection .....	All outputs protected from short circuit and overload with automatic recovery when the short or overload is removed.
Overvoltage protection <sup>1</sup> .....	115 to 140% above nominal output voltage

## PXI Subsystem Cooling

Per slot cooling capacity .....	25 W with fan speed set to HIGH
Slot airflow direction .....	P1 to P2, bottom of module to top of module

### Module cooling

System.....	Forced air circulation (positive pressurization) using one 115 cfm fan with HIGH/AUTO speed selector
Intake .....	Bottom rear of chassis
Exhaust.....	Along both sides and top of chassis

### Power supply cooling

System.....	Forced air circulation through integrated fan
Intake .....	Right side of chassis
Exhaust.....	Left side of chassis

## Safety

The PXI-1052 was evaluated using the criteria of EN 61010-1 and meets the requirements of the following standards for safety and electrical equipment for measurement, control, and laboratory use:

- EN 61010-1, IEC 61010-1
- UL 3111-1, UL 61010B-1
- CAN/CSA C22.2 No. 1010.1

---

<sup>1</sup> To reset over-voltage protection, remove the AC power cable for 30 seconds and then restore power.



**Note** For UL and other safety certifications, refer to the product label, or visit [ni.com/hardref.nsf](http://ni.com/hardref.nsf), search by model number or product line, and click the appropriate link in the Certification column.

## Electromagnetic Compatibility

Emissions .....	EN 55011 Class A at 10 m FCC Part 15A above 1 GHz
Immunity .....	EN 61326:1997 + A2:2001, Table 1
EMC/EMI .....	CE, C-Tick, and FCC Part 15 (Class A) compliant



**Notes** For EMC compliance, you *must* operate this device with shielded cabling. In addition, all covers and filler panels must be installed.

## CE Compliance

This product meets the essential requirements of applicable European Directives, as amended for CE marking, as follows:

Low-Voltage Directive (safety).....73/23/EEC

Electromagnetic Compatibility  
Directive (EMC).....89/336/EEC



**Note** Refer to the Declaration of Conformity (DoC) for this product for any additional regulatory compliance information. To obtain the DoC for this product, visit [ni.com/hardref.nsf](http://ni.com/hardref.nsf), search by model number or product line, and click the appropriate link in the Certification column.

## Operating Environment

Indoor use only

Ambient temperature range.....	0 to 55 °C (Tested in accordance with IEC-60068-2-1 and IEC-60068-2-2.)
Operating relative humidity .....	10 to 90%, noncondensing (Tested in accordance with IEC-60068-2-56.)
Altitude.....	2,000 m (at 25 °C ambient temperature)
Pollution Degree .....	2

## Storage Environment

Ambient temperature range.....	-20 to 70 °C (Tested in accordance with IEC-60068-2-1 and IEC-60068-2-2.)
Storage relative humidity .....	5 to 95%, noncondensing (Tested in accordance with IEC-60068-2-56.)

## Shock and Vibration

Operational shock .....	30 g peak, half-sine, 11 ms pulse (Tested in accordance with IEC-60068-2-27. Test profile developed in accordance with MIL-PRF-28800F.)
Random Vibration	
Operating .....	5 to 500 Hz, 0.3 g <sub>rms</sub>
Nonoperating .....	5 to 500 Hz, 2.4 g <sub>rms</sub> (Tested in accordance with IEC-60068-2-64. Nonoperating test profile exceeds the requirements of MIL-PRF-28800F, Class 3.)

## Backplane

Size .....	3U-sized; one system slot (with three system expansion slots) and 3 peripheral slots. Compliant with IEEE 1101.10 mechanical packaging. PXI Hardware Specification, Revision 2.1 compliant. Accepts both PXI and CompactPCI (PICMG 2.0 R 3.0) 3U modules.
V(I/O) <sup>1</sup> .....	+5 V
Backplane bare-board material .....	UL 94 V-0 recognized
Backplane connectors .....	Conforms to IEC 917 and IEC 1076-4-101, and are UL 94 V-0 rated

## 10 MHz System Reference Clock (10 MHz REF)

Maximum clock skew between slots.....	500 ps
Built-in 10 MHz clock	
Accuracy .....	±100 ppm (guaranteed over the operating temperature range)
Maximum jitter .....	15 ps RMS in 10 Hz to 1 MHz range

## Mechanical

Overall dimensions (standard chassis)	
Height × Width × Depth .....	177 mm × 438.2 mm × 452.9 mm (6.97 in.) × 17.25 in. × 17.83 in.)



**Note** 14.5 mm (0.57 in.) is added to height when feet are installed. When tilted with front feet extended on table top, height is increased approximately 52.8 mm (2.08 in.) in front and 14.8 mm (0.583 in.) in rear.

---

<sup>1</sup> V(I/O) is connected to the +5 V DC power plane, so the same specs apply to V(I/O) and +5 V.

Weight.....	10 kg (22.0 lbs)
Chassis materials.....	Sheet aluminum (EN AW-5754-H22, EN AW-5005-H14), extruded aluminum (6063-T6), cold rolled steel, PC/ABS, Santoprene, nylon
Finish.....	Conductive clear Iridite on aluminum, clear chromate zinc on cold rolled steel, electroplated nickel on cold rolled steel, epoxy/polyester powder coat.

Figure A-1 and Figure A-2 show the PXI-1052 dimensions. The holes shown are for the installation of the optional rack-mount kits as shown in Figure A-3. The front and rear rack mounting holes (size M4) are symmetrical.

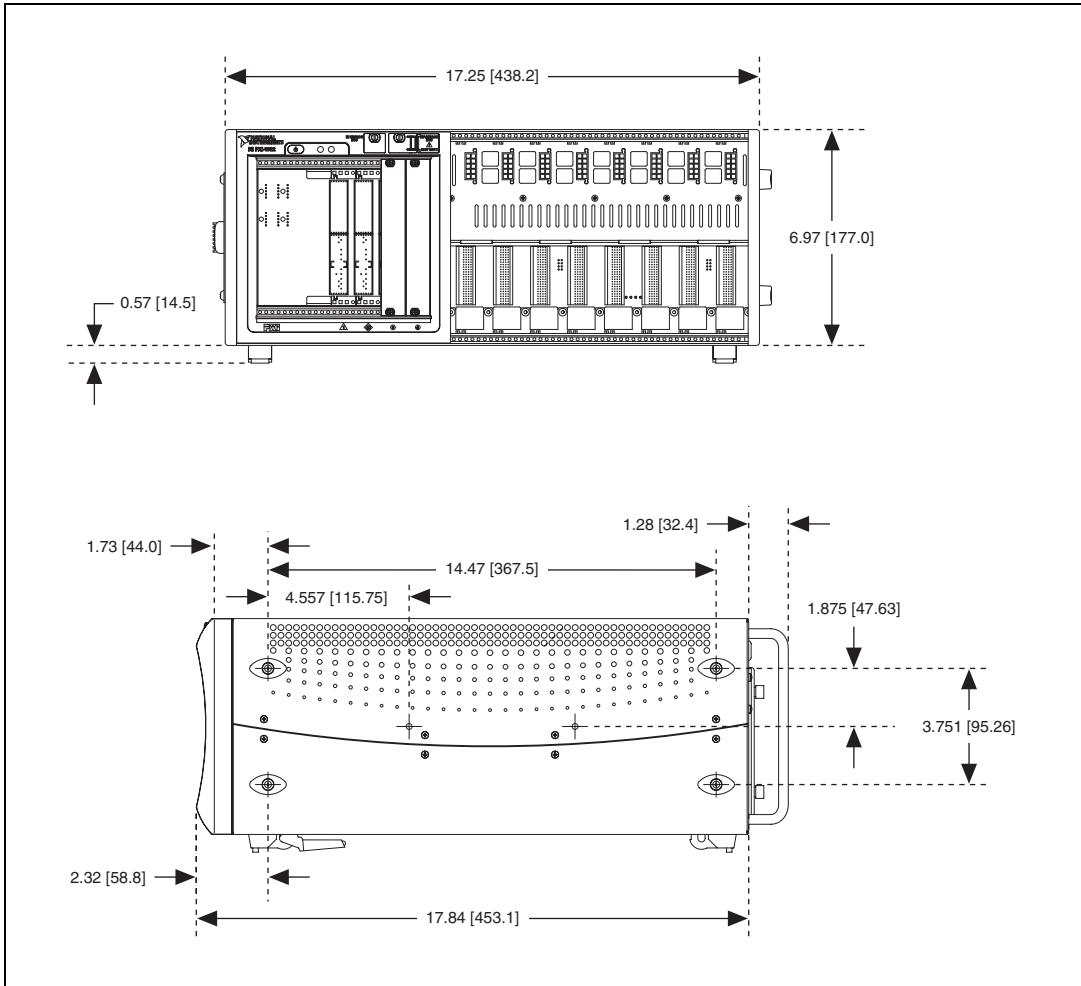

**Figure A-1.** PXI-1052 Dimensions (Front and Side) in Inches (mm)

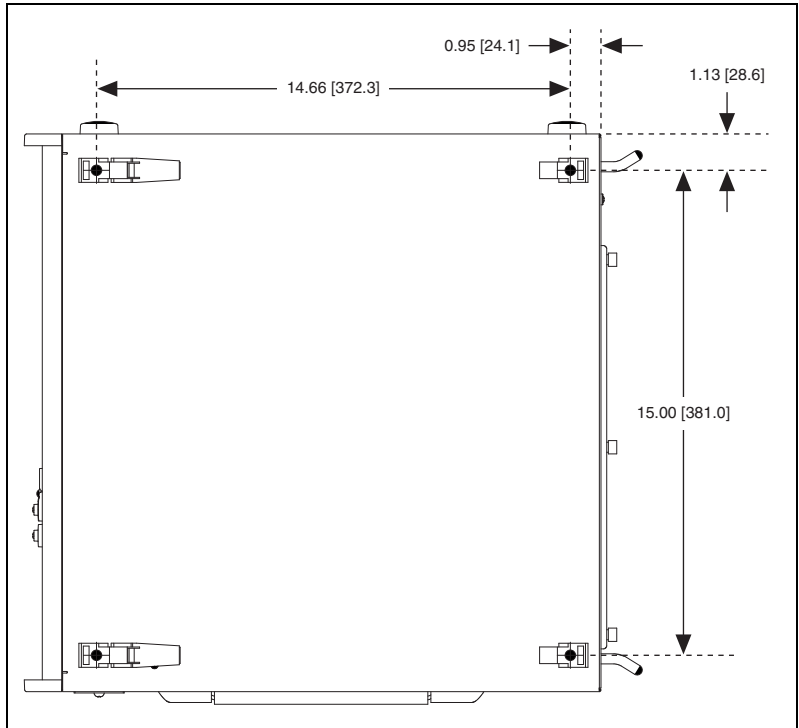

**Figure A-2.** PXI-1052 Dimensions (Bottom) in Inches (mm)

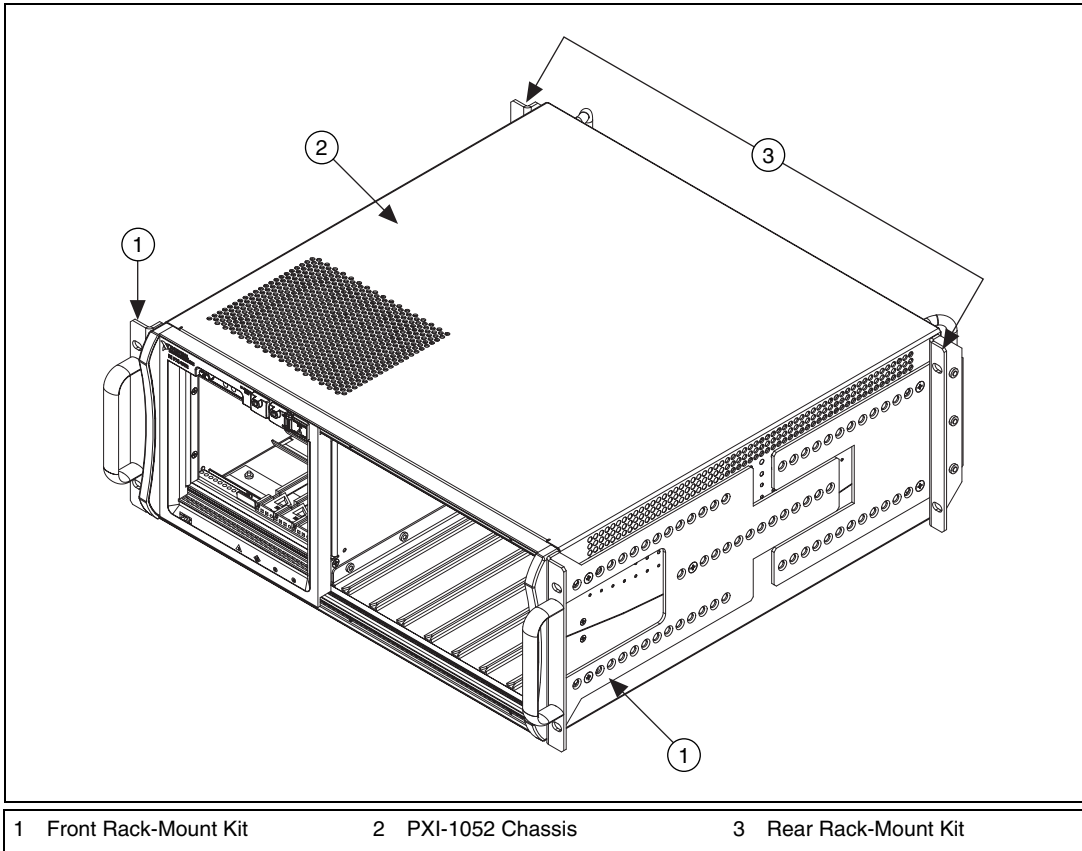

**Figure A-3.** PXI-1052 Rack Mount Kit Components

---

# Pinouts

This appendix describes the P1 and P2 connector pinouts for the PXI-1052 backplane.

Table B-1 shows the P1 (J1) connector pinout for the System Controller slot.

Table B-2 shows the P2 (J2) connector pinout for the System Controller slot.

Table B-3 shows the P1 (J1) connector pinout for the star trigger slot.

Table B-4 shows the P2 (J2) connector pinout for the star trigger slot.

Table B-5 shows the P1 (J1) connector pinout for the peripheral slots.

Table B-6 shows the P2 (J2) connector pinout for the peripheral slots.



**Note** PXI signals are shown in bold.

For more detailed information, refer to the *PXI Hardware Specification, Revision 2.1*. Contact the PXI Systems Alliance for a copy of the specification or visit [www.pxisa.org](http://www.pxisa.org).

**Table B-1.** P1 (J1) Connector Pinout for the System Controller Slot

Pin	Z	A	B	C	D	E	F
25	GND	5V	REQ64#	ENUM#	3.3V	5V	GND
24	GND	AD[1]	5V	V(I/O)	AD[0]	ACK64#	GND
23	GND	3.3V	AD[4]	AD[3]	5V	AD[2]	GND
22	GND	AD[7]	GND	3.3V	AD[6]	AD[5]	GND
21	GND	3.3V	AD[9]	AD[8]	M66EN	C/BE[0]#	GND
20	GND	AD[12]	GND	V(I/O)	AD[11]	AD[10]	GND
19	GND	3.3V	AD[15]	AD[14]	GND	AD[13]	GND
18	GND	SERR#	GND	3.3V	PAR	C/BE[1]#	GND
17	GND	3.3V	IPMB_SCL	IPMB_SDA	GND	PERR#	GND
16	GND	DEVSEL#	GND	V(I/O)	STOP#	LOCK#	GND
15	GND	3.3V	FRAME#	IRDY#	GND	TRDY#	GND
12–14	Key Area						
11	GND	AD[18]	AD[17]	AD[16]	GND	C/BE[2]#	GND
10	GND	AD[21]	GND	3.3V	AD[20]	AD[19]	GND
9	GND	C/BE[3]#	GND	AD[23]	GND	AD[22]	GND
8	GND	AD[26]	GND	V(I/O)	AD[25]	AD[24]	GND
7	GND	AD[30]	AD[29]	AD[28]	GND	AD[27]	GND
6	GND	REQ0#	GND	3.3V	CLK0	AD[31]	GND
5	GND	BRSVP1A5	BRSVP1B5	RST#	GND	GNT0#	GND
4	GND	IPMB_PWR	HEALTHY	V(I/O)	INTP	INTS	GND
3	GND	INTA#	INTB#	INTC#	5V	INTD#	GND
2	GND	TCK	5V	TMS	TDO	TDI	GND
1	GND	5V	-12V	TRST#	+12V	5V	GND

**Table B-2.** P2 (J2) Connector Pinout for the System Controller Slot

Pin	Z	A	B	C	D	E	F
22	GND	GA4	GA3	GA2	GA1	GA0	GND
21	GND	CLK6	GND	RSV	RSV	RSV	GND
20	GND	CLK5	GND	RSV	GND	RSV	GND
19	GND	GND	GND	SMB_SDA	SMB_SCL	SMB_ALERT#	GND
18	GND	<b>PXI_TRIG3</b>	<b>PXI_TRIG4</b>	<b>PXI_TRIG5</b>	GND	<b>PXI_TRIG6</b>	GND
17	GND	<b>PXI_TRIG2</b>	GND	PRST#	REQ6#	GNT6#	GND
16	GND	<b>PXI_TRIG1</b>	<b>PXI_TRIG0</b>	DEG#	GND	<b>PXI_TRIG7</b>	GND
15	GND	<b>PXI_BRSVA15</b>	GND	FAL#	REQ5#	GNT5#	GND
14	GND	AD[35]	AD[34]	AD[33]	GND	AD[32]	GND
13	GND	AD[38]	GND	V(I/O)	AD[37]	AD[36]	GND
12	GND	AD[42]	AD[41]	AD[40]	GND	AD[39]	GND
11	GND	AD[45]	GND	V(I/O)	AD[44]	AD[43]	GND
10	GND	AD[49]	AD[48]	AD[47]	GND	AD[46]	GND
9	GND	AD[52]	GND	V(I/O)	AD[51]	AD[50]	GND
8	GND	AD[56]	AD[55]	AD[54]	GND	AD[53]	GND
7	GND	AD[59]	GND	V(I/O)	AD[58]	AD[57]	GND
6	GND	AD[63]	AD[62]	AD[61]	GND	AD[60]	GND
5	GND	C/BE[5]#	GND	V(I/O)	C/BE[4]#	PAR64	GND
4	GND	V(I/O)	<b>PXI_BRSVB4</b>	C/BE[7]#	GND	C/BE[6]#	GND
3	GND	CLK4	GND	GNT3#	REQ4#	GNT4#	GND
2	GND	CLK2	CLK3	SYSEN#	GNT2#	REQ3#	GND
1	GND	CLK1	GND	REQ1#	GNT1#	REQ2#	GND

**Table B-3.** P1 (J1) Connector Pinout for the Star Trigger Slot

Pin	Z	A	B	C	D	E	F
25	GND	5V	REQ64#	ENUM#	3.3V	5V	GND
24	GND	AD[1]	5V	V(I/O)	AD[0]	ACK64#	GND
23	GND	3.3V	AD[4]	AD[3]	5V	AD[2]	GND
22	GND	AD[7]	GND	3.3V	AD[6]	AD[5]	GND
21	GND	3.3V	AD[9]	AD[8]	M66EN	C/BE[0]#	GND
20	GND	AD[12]	GND	V(I/O)	AD[11]	AD[10]	GND
19	GND	3.3V	AD[15]	AD[14]	GND	AD[13]	GND
18	GND	SERR#	GND	3.3V	PAR	C/BE[1]#	GND
17	GND	3.3V	IPMB_SCL	IPMB_SDA	GND	PERR#	GND
16	GND	DEVSEL#	GND	V(I/O)	STOP#	LOCK#	GND
15	GND	3.3V	FRAME#	IRDY#	BD_SEL#	TRDY#	GND
12–14	Key Area						
11	GND	AD[18]	AD[17]	AD[16]	GND	C/BE[2]#	GND
10	GND	AD[21]	GND	3.3V	AD[20]	AD[19]	GND
9	GND	C/BE[3]#	IDSEL	AD[23]	GND	AD[22]	GND
8	GND	AD[26]	GND	V(I/O)	AD[25]	AD[24]	GND
7	GND	AD[30]	AD[29]	AD[28]	GND	AD[27]	GND
6	GND	REQ#	GND	3.3V	CLK	AD[31]	GND
5	GND	BRSVP1A5	BRSVP1B5	RST#	GND	GNT#	GND
4	GND	IPMB_PWR	HEALTHY	V(I/O)	INTP	INTS	GND
3	GND	INTA#	INTB#	INTC#	5V	INTD#	GND
2	GND	TCK	5V	TMS	TDO	TDI	GND
1	GND	5V	-12V	TRST#	+12V	5V	GND

**Table B-4.** P2 (J2) Connector Pinout for the Star Trigger Slot

Pin	Z	A	B	C	D	E	F
22	GND	GA4	GA3	GA2	GA1	GA0	GND
21	GND	<b>PXI_LBR0</b>	RSV	<b>PXI_LBR1</b>	<b>PXI_LBR2</b>	<b>PXI_LBR3</b>	GND
20	GND	<b>PXI_LBR4</b>	<b>PXI_LBR5</b>	<b>PXI_STAR0</b>	GND	<b>PXI_STAR1</b>	GND
19	GND	<b>PXI_STAR2</b>	RSV	<b>PXI_STAR3</b>	<b>PXI_STAR4</b>	<b>PXI_STAR5</b>	GND
18	GND	<b>PXI_TRIG3</b>	<b>PXI_TRIG4</b>	<b>PXI_TRIG5</b>	GND	<b>PXI_TRIG6</b>	GND
17	GND	<b>PXI_TRIG2</b>	GND	RSV	<b>PXI_CLK10_IN</b>	<b>PXI_CLK10</b>	GND
16	GND	<b>PXI_TRIG1</b>	<b>PXI_TRIG0</b>	RSV	GND	<b>PXI_TRIG7</b>	GND
15	GND	<b>PXI_BRSVA15</b>	GND	RSV	<b>PXI_STAR6</b>	<b>PXI_LBR6</b>	GND
14	GND	AD[35]	AD[34]	AD[33]	GND	AD[32]	GND
13	GND	AD[38]	GND	V(I/O)	AD[37]	AD[36]	GND
12	GND	AD[42]	AD[41]	AD[40]	GND	AD[39]	GND
11	GND	AD[45]	GND	V(I/O)	AD[44]	AD[43]	GND
10	GND	AD[49]	AD[48]	AD[47]	GND	AD[46]	GND
9	GND	AD[52]	GND	V(I/O)	AD[51]	AD[50]	GND
8	GND	AD[56]	AD[55]	AD[54]	GND	AD[53]	GND
7	GND	AD[59]	GND	V(I/O)	AD[58]	AD[57]	GND
6	GND	AD[63]	AD[62]	AD[61]	GND	AD[60]	GND
5	GND	C/BE[5]#	GND	V(I/O)	C/BE[4]#	PAR64	GND
4	GND	V(I/O)	<b>PXI_BRSVB4</b>	C/BE[7]#	GND	C/BE[6]#	GND
3	GND	<b>PXI_LBR7</b>	GND	<b>PXI_LBR8</b>	<b>PXI_LBR9</b>	<b>PXI_LBR10</b>	GND
2	GND	<b>PXI_LBR11</b>	<b>PXI_LBR12</b>	UNC	<b>PXI_STAR7</b>	<b>PXI_STAR8</b>	GND
1	GND	<b>PXI_STAR9</b>	GND	<b>PXI_STAR10</b>	<b>PXI_STAR11</b>	<b>PXI_STAR12</b>	GND

**Table B-5.** P1 (J1) Connector Pinout for the Generic Peripheral Slot

Pin	Z	A	B	C	D	E	F
25	GND	5V	REQ64#	ENUM#	3.3V	5V	GND
24	GND	AD[1]	5V	V(I/O)	AD[0]	ACK64#	GND
23	GND	3.3V	AD[4]	AD[3]	5V	AD[2]	GND
22	GND	AD[7]	GND	3.3V	AD[6]	AD[5]	GND
21	GND	3.3V	AD[9]	AD[8]	M66EN	C/BE[0]#	GND
20	GND	AD[12]	GND	V(I/O)	AD[11]	AD[10]	GND
19	GND	3.3V	AD[15]	AD[14]	GND	AD[13]	GND
18	GND	SERR#	GND	3.3V	PAR	C/BE[1]#	GND
17	GND	3.3V	IPMB_SCL	IPMB_SDA	GND	PERR#	GND
16	GND	DEVSEL#	GND	V(I/O)	STOP#	LOCK#	GND
15	GND	3.3V	FRAME#	IRDY#	BD_SEL#	TRDY#	GND
12–14	Key Area						
11	GND	AD[18]	AD[17]	AD[16]	GND	C/BE[2]#	GND
10	GND	AD[21]	GND	3.3V	AD[20]	AD[19]	GND
9	GND	C/BE[3]#	IDSEL	AD[23]	GND	AD[22]	GND
8	GND	AD[26]	GND	V(I/O)	AD[25]	AD[24]	GND
7	GND	AD[30]	AD[29]	AD[28]	GND	AD[27]	GND
6	GND	REQ#	GND	3.3V	CLK	AD[31]	GND
5	GND	BRSVP1A5	BRSVP1B5	RST#	GND	GNT#	GND
4	GND	IPMB_PWR	HEALTHY	V(I/O)	INTP	INTS	GND
3	GND	INTA#	INTB#	INTC#	5V	INTD#	GND
2	GND	TCK	5V	TMS	TDO	TDI	GND
1	GND	5V	-12V	TRST#	+12V	5V	GND

**Table B-6.** P2 (J2) Connector Pinout for the Generic Peripheral Slot

Pin	Z	A	B	C	D	E	F
22	GND	GA4	GA3	GA2	GA1	GA0	GND
21	GND	<b>PXI_LBR0</b>	RSV	<b>PXI_LBR1</b>	<b>PXI_LBR2</b>	<b>PXI_LBR3</b>	GND
20	GND	<b>PXI_LBR4</b>	<b>PXI_LBR5</b>	<b>PXI_LBL0</b>	GND	<b>PXI_LBL1</b>	GND
19	GND	<b>PXI_LBL2</b>	RSV	<b>PXI_LBL3</b>	<b>PXI_LBL4</b>	<b>PXI_LBL5</b>	GND
18	GND	<b>PXI_TRIG3</b>	<b>PXI_TRIG4</b>	<b>PXI_TRIG5</b>	GND	<b>PXI_TRIG6</b>	GND
17	GND	<b>PXI_TRIG2</b>	GND	RSV	<b>PXI_STAR</b>	<b>PXI_CLK10</b>	GND
16	GND	<b>PXI_TRIG1</b>	<b>PXI_TRIG0</b>	RSV	GND	<b>PXI_TRIG7</b>	GND
15	GND	<b>PXI_BRSVA15</b>	GND	RSV	<b>PXI_LBL6</b>	<b>PXI_LBR6</b>	GND
14	GND	AD[35]	AD[34]	AD[33]	GND	AD[32]	GND
13	GND	AD[38]	GND	V(I/O)	AD[37]	AD[36]	GND
12	GND	AD[42]	AD[41]	AD[40]	GND	AD[39]	GND
11	GND	AD[45]	GND	V(I/O)	AD[44]	AD[43]	GND
10	GND	AD[49]	AD[48]	AD[47]	GND	AD[46]	GND
9	GND	AD[52]	GND	V(I/O)	AD[51]	AD[50]	GND
8	GND	AD[56]	AD[55]	AD[54]	GND	AD[53]	GND
7	GND	AD[59]	GND	V(I/O)	AD[58]	AD[57]	GND
6	GND	AD[63]	AD[62]	AD[61]	GND	AD[60]	GND
5	GND	C/BE[5]#	GND	V(I/O)	C/BE[4]#	PAR64	GND
4	GND	V(I/O)	<b>PXI_BRSVB4</b>	C/BE[7]#	GND	C/BE[6]#	GND
3	GND	<b>PXI_LBR7</b>	GND	<b>PXI_LBR8</b>	<b>PXI_LBR9</b>	<b>PXI_LBR10</b>	GND
2	GND	<b>PXI_LBR11</b>	<b>PXI_LBR12</b>	UNC	<b>PXI_LBL7</b>	<b>PXI_LBL8</b>	GND
1	GND	<b>PXI_LBL9</b>	GND	<b>PXI_LBL10</b>	<b>PXI_LBL11</b>	<b>PXI_LBL12</b>	GND



---

# Technical Support and Professional Services

Visit the following sections of the National Instruments Web site at [ni.com](http://ni.com) for technical support and professional services:

- **Support**—Online technical support resources include the following:
  - **Self-Help Resources**—For immediate answers and solutions, visit our extensive library of technical support resources available in English, Japanese, and Spanish at [ni.com/support](http://ni.com/support). These resources are available for most products at no cost to registered users and include software drivers and updates, a KnowledgeBase, product manuals, step-by-step troubleshooting wizards, conformity documentation, example code, tutorials and application notes, instrument drivers, discussion forums, a measurement glossary, and so on.
  - **Assisted Support Options**—Contact NI engineers and other measurement and automation professionals by visiting [ni.com/support](http://ni.com/support). Our online system helps you define your question and connects you to the experts by phone, discussion forum, or email.
- **Training and Certification**—Visit [ni.com/training](http://ni.com/training) for self-paced training, eLearning virtual classrooms, interactive CDs, and Certification program information. You also can register for instructor-led, hands-on courses at locations around the world.
- **System Integration**—If you have time constraints, limited in-house technical resources, or other project challenges, NI Alliance Program members can help. To learn more, call your local NI office or visit [ni.com/alliance](http://ni.com/alliance).
- **Declaration of Conformity (DoC)**—A DoC is our claim of compliance with the Council of the European Communities using the manufacturer’s declaration of conformity. This system affords the user protection for electronic compatibility (EMC) and product safety. You can obtain the DoC for your product by visiting [ni.com/hardref.nsf](http://ni.com/hardref.nsf).

If you searched [ni.com](http://ni.com) and could not find the answers you need, contact your local office or NI corporate headquarters. Phone numbers for our worldwide offices are listed at the front of this manual. You also can visit the Worldwide Offices section of [ni.com/niglobal](http://ni.com/niglobal) to access the branch office Web sites, which provide up-to-date contact information, support phone numbers, email addresses, and current events.

# Glossary

---

Symbol	Prefix	Value
p	pico	$10^{-12}$
n	nano	$10^{-9}$
$\mu$	micro	$10^{-6}$
m	milli	$10^{-3}$
k	kilo	$10^3$
M	mega	$10^6$
G	giga	$10^9$
T	tera	$10^{12}$

## Symbols

°	Degrees.
$\geq$	Equal or greater than.
$\leq$	Equal or less than.
%	Percent.
$\Omega$	Ohms.

## A

A	Amperes.
AC	Alternating current.
ANSI	American National Standards Institute.
AUTO	Automatic fan speed control.
AWG	American Wire Gauge.

## B

backplane An assembly, typically a printed circuit board, with connectors and signal paths that interconnect the connector pins.

BNC Bayonet Neill Concelman connector; a commonly used coaxial connector.

## C

C Celsius.

cfm Cubic feet per minute.

CFR Code of Federal Regulations.

cm Centimeters.

CompactPCI An adaptation of the Peripheral Component Interconnect (PCI) Specification 2.1 or later for industrial and/or embedded applications requiring a more robust mechanical form factor than desktop PCI. It uses industry standard mechanical components and high-performance connector technologies to provide an optimized system intended for rugged applications. It is electrically compatible with the PCI Specification, which enables low-cost PCI components to be utilized in a mechanical form factor suited for rugged environments.

CSA Canadian Standards Association.

## D

daisy-chain A method of propagating signals along a bus, in which the devices are prioritized on the basis of their position on the bus.

DB-9 A 9-pin D-Sub connector.

DC Direct current.

DoC Declaration of Conformity.

D-Sub Subminiature D connector.

**E**

efficiency	Ratio of output power to input power, expressed as a percentage.
EIA	Electronic Industries Association.
EMC	Electromagnetic Compatibility.
EMI	Electromagnetic Interference.
Embedded system controller	A module configured for installation in slot 1 of a PXI chassis. This device is unique in the PXI system in that it performs the system controller functions, including clock sourcing and arbitration for data transfers across the backplane. Installing such a device into any other slot can damage the device, the PXI backplane, or both.

**F**

FCC	Federal Communications Commission.
filler panel	A blank module front panel used to fill empty slots in the chassis.

**G**

g	(1) grams; (2) a measure of acceleration approximately equal to $9.8 \text{ m/s}^2$ .
global channel	A <i>virtual channel</i> created outside of a <i>task</i> . A virtual channel defined inside a task is a <i>local channel</i> .
GPIB	General Purpose Interface Bus (IEEE 488).
$g_{\text{RMS}}$	A measure of random vibration. The root mean square of acceleration levels in a random vibration test profile.

**H**

hr	Hours.
Hz	Hertz; cycles per second.

## I

IEC	International Electrotechnical Commission; an organization that sets international electrical and electronics standards.
IEEE	Institute of Electrical and Electronics Engineers.
$I_{MP}$	Mainframe peak current.
in.	Inches.
inhibit	To power off.

## J

jitter	A measure of the small, rapid variations in clock transition times from their nominal regular intervals. Units: seconds RMS.
--------	--

## K

kg	Kilograms.
km	Kilometers.

## L

lb	Pounds.
LED	Light emitting diode.
line regulation	The maximum steady-state percentage that a DC voltage output changes as a result of a specified change in input AC voltage (step change from 90 to 132 VAC or 180 to 264 VAC).
load regulation	The maximum steady-state percentage that a DC voltage output changes as a result of a step change from no-load to full-load output current.
local channel	A <i>virtual channel</i> created inside a <i>task</i> . A virtual channel defined outside of a task is a <i>global channel</i> .

**M**

m	Meters.
MAX	NI Measurement & Automation Explorer, the utility that allows you to configure and test the PXI system.
MHz	Megahertz. One million Hertz; one Hertz equals one cycle per second.
ms	Millisecond, one thousandth of a second ( $10^{-3}$ ).
MTBF	Mean time between failure.
MTTR	Mean time to repair.

**N**

NEMA	National Electrical Manufacturers Association.
NI	National Instruments.
NI-DAQmx	National Instruments driver which controls the operation of National Instruments data acquisition (DAQ) devices.
NI-VISA	National Instruments implementation of the VISA (Virtual Instrument System Architecture) I/O standard. NI-VISA provides support for the VISA API, and also provides VISAIC, a utility for instrument configuration and I/O function execution.
ns	Nanosecond, one billionth of a second ( $10^{-9}$ ).

**P**

physical channel	A terminal or pin at which you can measure or generate an analog or digital signal.
ppm	Parts-per-million.
power-supply shuttle	A removable module that contains the chassis power supply.
ps	Picosecond, one trillionth of a second ( $10^{-12}$ ).

**PXI** PCI eXtensions for Instrumentation. PXI is an implementation of CompactPCI with added electrical features that meet the high performance requirements of instrumentation applications by providing triggering, local buses, and system clock capabilities.

**PXI\_CLK10** 10 MHz PXI system reference clock.

## R

**RMS** Root mean square.

## S

**s** Seconds.

**skew** Deviation in signal transmission times.

**slot blocker** An assembly installed into an empty slot to improve the airflow in adjacent slots.

**standby** The backplane is unpowered (off), but the chassis is still connected to AC power mains.

**star trigger slot** This slot is located at Slot 2 and has a dedicated trigger line between each peripheral slot. Use this slot for a module with star trigger functionality that can provide individual triggers to all other peripherals.

**system reference clock** A 10 MHz clock, also called PXI\_CLK10, that is distributed to all peripheral slots in the chassis. The system reference clock is used for synchronization of multiple modules in a measurement or control system. The PXI backplane specification defines implementation guidelines for PXI\_CLK10.

## T

**task** In NI-DAQmx, a collection of one or more virtual channels with timing, triggering, and other properties.

**TTL** Transistor-transistor logic.

**U**

UL Underwriter's Laboratories.

**V**

V Volts.

VAC Volts alternating current, or  $V_{\text{rms}}$ .

virtual channel A collection of settings that can include a name, a physical channel, input terminal connections, the type of measurement or generation, and scaling information. In Traditional NI-DAQ and earlier versions, configuring virtual channels is an optional way to record which channels are being used for different measurements. In NI-DAQmx, virtual channels are integral to every measurement.

$V_{\text{pp}}$  Peak-to-peak voltage.

**W**

W Watts.

# Index

---

## A

AC power cables (table), 1-2

## B

backplane

interoperability with CompactPCI, 1-6

local bus, 1-7

overview, 1-5

peripheral slots, 1-6

specifications, A-6

star trigger slot, 1-6

system reference clock, 1-8

trigger bus, 1-7

## C

cables, power (table), 1-2

chassis initialization file, 2-13

CompactPCI

installing modules (figure), 2-9

interoperability with PXI-1052

backplane, 1-6

configuration. *See* installation, configuration, and operation

connector pinouts. *See* pinouts

conventions used in the manual, *vii*

cooling

air cooling of PXI-1052, 2-2

air intake (figure), 2-2

filler panel installation, 2-3

setting fan speed, 2-3

slot blocker installation, 2-3

customer

professional services, C-1

technical support, C-1

## D

Declaration of Conformity (NI resources), C-1

diagnostic tools (NI resources), C-1

dimensions (figure), A-8, A-9

documentation

conventions used in manual, *vii*

related documentation, *viii*

drivers (NI resources), C-1

D-Sub connector

pinout (table), 2-20

power supply voltages (table), 2-21

## E

electromagnetic compatibility, A-4

examples (NI resources), C-1

## F

fan, setting speed, 2-3

filler panel installation, 2-3

SCXI subsystem, 2-9, 2-10

## G

ground, connecting, 2-4

## H

help

professional services, C-1

technical support, C-1

## I

- installation
  - SCXI filler panels, 2-9, 2-10
  - SCXI modules, 2-10
- installation, configuration, and operation
  - chassis initialization file, 2-13
  - configuration in MAX (figure), 2-11
  - connecting safety ground, 2-4
  - filler panel installation, 2-3
  - installing a PXI controller, 2-6
  - module installation, 2-6, 2-8
    - CompactPCI or PXI modules (figure), 2-9
    - injector/ejector handle position (figure), 2-6
  - PXI configuration in MAX, 2-10
    - trigger configuration, 2-12
  - PXI controller installed in a PXI-1052 chassis (figure), 2-7
  - rack mounting, 2-3
  - remote voltage monitoring and inhibiting connector, 2-19
  - setting fan speed, 2-3
  - site considerations, 2-2
  - slot blocker installation, 2-3
  - testing power up, 2-4
  - unpacking the PXI-1052, 1-1
- instrument drivers (NI resources), C-1
- interoperability with CompactPCI, 1-6

## K

- key features, 1-2
- kit contents, 1-1
- KnowledgeBase, C-1

## L

- local bus
  - routing (figure), 1-7
  - star trigger and local bus routing (figure), 1-8

## M

- maintenance of PXI-1052, 3-1
  - cleaning
    - exterior cleaning, 3-2
    - fan filters, 3-3
    - interior cleaning, 3-2
  - preparation, 3-1
  - resetting the AC mains circuit breaker, 3-3
  - service interval, 3-1
  - static discharge damage (caution), 3-1

## N

- National Instruments
  - professional services, C-1
  - technical support, C-1
- National Instruments support and services, C-1

## O

- online technical support, C-1
- optional equipment, 1-5

## P

- P1 (J1) connector
  - peripheral slot (table), B-6
  - star trigger slot (table), B-4
  - system controller slot (table), B-2

P2 (J2) connector  
 peripheral slot (table), B-7  
 star trigger slot (table), B-5  
 system controller slot (table), B-3

peripheral slots  
 overview, 1-6

P1 (J1) connector pinouts (table), B-6

P2 (J2) connector pinouts (table), B-7

pinouts, B-1

D-Sub connector (table), 2-20

P1 (J1) connector  
 peripheral slot (table), B-6  
 star trigger slot (table), B-4  
 system controller slot (table), B-2

P2 (J2) connector  
 peripheral slot (table), B-7  
 star trigger slot (table), B-5  
 system controller slot (table), B-3

power cables (table), 1-2

power supply  
 connecting to, 2-4  
 remote voltage monitoring and inhibiting connector, 2-19  
 voltages at voltage monitoring connector (D-Sub) (table), 2-20

power switch LED indicators, 2-5

power up, testing, 2-4

professional services, C-1

programming examples (NI resources), C-1

PXI controller, 2-6  
 installing in a PXI-1052 chassis (figure), 2-7

PXI subsystem  
 SCXI control slot, 1-7  
 star trigger and local bus routing (figure), 1-8

PXI\_CLK10, 1-8

PXI\_CLK10\_IN pin, 1-8

PXI-1011 chassis. *See* PXI subsystem

PXI-1052  
 cooling air intake (figure), 2-2  
 fan speed, setting, 2-3  
 front view (figure), 1-4  
 installation. *See* installation, configuration, and operation  
 key features, 1-2  
 maintenance. *See* maintenance of PXI-1052  
 optional equipment, 1-5  
 rack mounting, 2-3  
 rear view of chassis, 1-5  
 safety ground, connecting, 2-4

PXI-1052 backplane  
 interoperability with CompactPCI, 1-6  
 local bus, 1-7  
 overview, 1-5  
 peripheral slots, 1-6  
 specifications, A-6  
 star trigger slot, 1-6  
 system reference clock, 1-8  
 trigger bus, 1-7

PXI-1052 chassis  
 SCXI subsystem overview, 1-8

## R

rack mount kit dimensions (figure), A-10

rack mounting, 2-3

related documentation, *viii*

remote voltage monitoring and inhibiting connector  
 pinout (table), 2-19  
 power supply voltages (table), 2-21

## S

safety and caution notices, 2-1

safety ground, connecting, 2-4

safety specifications (table), A-3

SCXI subsystem

- control slot for PXI peripheral module, 1-7
- installation, filler panel, 2-10
- overview, 1-8
- service interval, 3-1
- setting fan speed, 2-3
- slot blocker, installation, 2-3
- software (NI resources), C-1
- specifications
  - backplane, A-6
  - dimensions (figure), A-8, A-9
  - electrical
    - AC input, A-1
    - DC output, A-2
  - electromagnetic compatibility, A-4
  - environmental, A-5
  - mechanical, A-6
  - pxi subsystem cooling, A-3
  - rack mount kit dimensions (figure), A-10
  - safety, A-3
- star trigger (ST) slot
  - description, 1-6
  - P1 (J1) connector pinouts (table), B-4
  - P2 (J2) connector pinouts (table), B-5
  - star trigger and local bus routing (figure), 1-8
- support, technical, C-1
- system controller slot
  - description, 1-6
  - P1 (J1) connector pinouts (table), B-2
  - P2 (J2) connector pinouts (table), B-3
- system reference clock, 1-8

**T**

- technical support, C-1
- testing power up, 2-4
- training and certification (NI resources), C-1
- trigger bus, 1-7
- troubleshooting (NI resources), C-1

**U**

- unpacking the PXI-1052, 1-1

**V**

- voltage monitoring connector. *See* D-Sub connector
- voltages at voltage monitoring connector (D-Sub) (table), 2-21

**W**

- Web
  - professional services, C-1
  - technical support, C-1