

SCXI™

SCXIbus System Specification

Signal Conditioning eXtensions for
Instrumentation System Specification

Worldwide Technical Support and Product Information

www.natinst.com

National Instruments Corporate Headquarters

11500 North Mopac Expressway Austin, Texas 78759-3504 USA Tel: 512 794 0100

Worldwide Offices

Australia 03 9879 5166, Austria 0662 45 79 90 0, Belgium 02 757 00 20, Brazil 011 284 5011,
Canada (Ontario) 905 785 0085, Canada (Québec) 514 694 8521, China 0755 3904939, Denmark 45 76 26 00,
Finland 09 725 725 11, France 01 48 14 24 24, Germany 089 741 31 30, Hong Kong 2645 3186,
India 91805275406, Israel 03 6120092, Italy 02 413091, Japan 03 5472 2970, Korea 02 596 7456,
Mexico (D.F.) 5 280 7625, Mexico (Monterrey) 8 357 7695, Netherlands 0348 433466, Norway 32 27 73 00,
Singapore 2265886, Spain (Madrid) 91 640 0085, Spain (Barcelona) 93 582 0251, Sweden 08 587 895 00,
Switzerland 056 200 51 51, Taiwan 02 2377 1200, United Kingdom 01635 523545

To comment on the documentation, send e-mail to techpubs@natinst.com.

© Copyright 1992, 1999 National Instruments Corporation. All rights reserved.

Important Information

Copyright

Under the copyright laws, this publication may not be reproduced or transmitted in any form, electronic or mechanical, including photocopying, recording, storing in an information retrieval system, or translating, in whole or in part, without the prior written consent of National Instruments Corporation.

Trademarks

natinst.com[™], and SCXI[™] are trademarks of National Instruments Corporation.

Product and company names mentioned herein are trademarks or trade names of their respective companies.

WARNING REGARDING MEDICAL AND CLINICAL USE OF NATIONAL INSTRUMENTS PRODUCTS

National Instruments products are not designed with components and testing for a level of reliability suitable for use in or in connection with surgical implants or as critical components in any life support systems whose failure to perform can reasonably be expected to cause significant injury to a human. Applications of National Instruments products involving medical or clinical treatment can create a potential for death or bodily injury caused by product failure, or by errors on the part of the user or application designer. Because each end-user system is customized and differs from National Instruments testing platforms and because a user or application designer may use National Instruments products in combination with other products in a manner not evaluated or contemplated by National Instruments, the user or application designer is ultimately responsible for verifying and validating the suitability of National Instruments products whenever National Instruments products are incorporated in a system or application, including, without limitation, the appropriate design, process and safety level of such system or application.

Conventions

The following conventions are used in this manual:



This icon denotes a note, which alerts you to important information.

bold

Bold text denotes items that you must select or click on in the software, such as menu items and dialog box options. Bold text also denotes parameter names.

italic

Italic text denotes variables, emphasis, a cross reference, or an introduction to a key concept. This font also denotes text that is a placeholder for a word or value that you must supply.

`monospace`

`Text in this font` denotes text or characters that you should enter from the keyboard, sections of code, programming examples, and syntax examples. This font is also used for the proper names of disk drives, paths, directories, programs, subprograms, subroutines, device names, functions, operations, variables, filenames and extensions, and code excerpts.

Contents

SCXibus System Specification

Introduction.....	1
Scope	1
Objectives	1
Physical Requirements.....	1
Module Dimensions.....	3
Connector Position	3
Threaded Strip Holes.....	3
Airflow Region.....	4
SCXibus Connector	4
SCXibus Connector Signal Descriptions	6
Electrical Requirements	7
Power Requirements.....	7
Analog Buses and Guard	8
Open-Collector Lines	8
HCT Input Lines.....	9
Timing Requirements and Specifications	9
RESET* Timing Requirements and Specifications	9
Digital Bus Timing Requirements and Specifications	9
Overview.....	9
MOSI, MISO, and SPICLK Timing	10
Slot-Select Procedure.....	11
Writes to Slot 0 Registers.....	12
Module Types and Communication Protocols.....	13
Class I Modules	13
Class II Modules	15
Module ID Protocol.....	18
SCANCON Timing Requirements and Specifications.....	18

Figures

Figure 1.	Dimensions for an SCXI Module	2
Figure 2.	SCXI Chassis SCXIBus Connector Pin Assignment	5
Figure 3.	Master and Slave Timing Diagram	11
Figure 4.	Slot-Select Timing Diagram	12
Figure 5.	Slot 0 Register Writes Diagram	13
Figure 6.	Class I Module Structure Diagram	14
Figure 7.	Class I Timing Diagram	15
Figure 8.	Class II Module Structure Diagram	16
Figure 9.	Class II Timing Diagram	17
Figure 10.	SCANCON and TRIG0 Timing Diagram.....	19

Tables

Table 1.	Right-Angle Female Metral Connector Part Numbers	3
Table 2.	Power Specifications.....	7
Table 3.	Supply Ratings	7

SCXIBus System Specification

Introduction

Scope

The Signal Conditioning eXtensions for Instrumentation bus (SCXIBus) is a multifunction bus that provides a serial communication bus, analog buses, trigger buses, and power to signal conditioning modules. The SCXIBus integrates many different signal conditioning functions into a single system that can be remotely configured and controlled.

Objectives

This specification describes the physical, electrical, and timing requirements for the SCXIBus. The system objectives of the SCXIBus specification are as follows:

- To specify the system characteristics that allow a module to control other modules or be controlled via the serial bus
- To specify the electrical and mechanical system characteristics required to design modules that will operate in the SCXIBus system

The *Physical Requirements* section describes the physical dimensions of an SCXI module, the positioning of the metal SCXIBus connector, and cooling information. The *SCXIBus Connector* section contains the pinout and a brief description of the SCXIBus backplane lines and requirements for module connections to these lines. The *Timing Requirements and Specifications* section contains a complete description and specification of the serial communications protocol and SCANCON timing.

Physical Requirements

This section discusses the physical dimensions of an SCXI module, the positioning of the metal SCXIBus connector, and cooling information. Figure 1 shows the physical dimensions for an SCXI module.

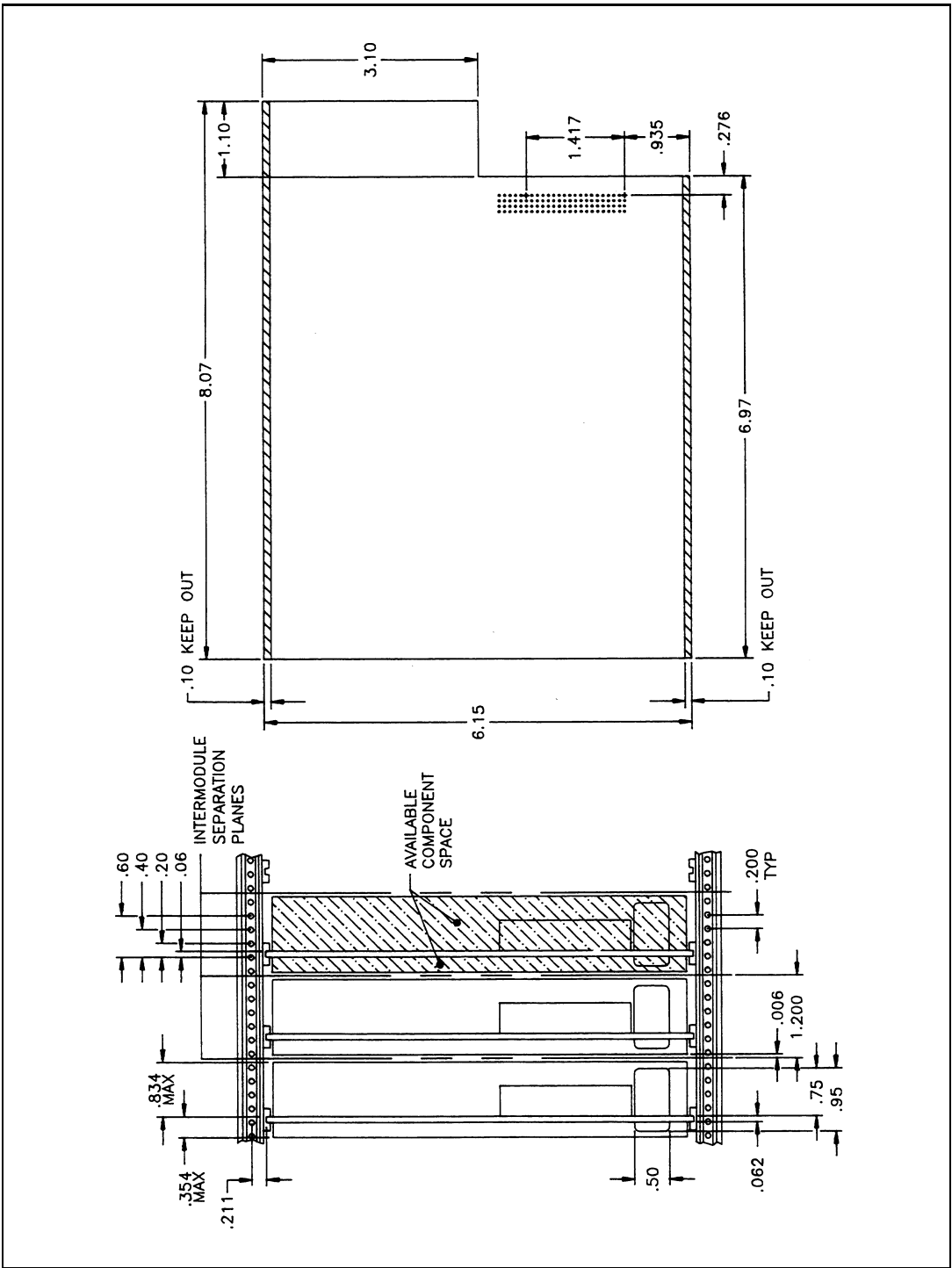

Figure 1. Dimensions for an SCXI Module

Module Dimensions

A module slides into the chassis on the plastic module guides. The edges of the module should be 0.062 in. thick to fit within the module guides. The module needs a keep-out area of 0.1 in. on the top and bottom of the module to keep components from rubbing against the module guides.

The module should be 6.15 in. high. The width limitations on a module are that no part of the module should come within 0.006 in. of the intermodule separation plane. For a properly aligned module, this equals a component height restriction of 0.834 in. on the top side of the board and 0.354 in. on the bottom side of the board. Notice that the component height restriction on the bottom side includes the thickness of the printed circuit board.

The depth of the module (distance front to back) should be 6.97 in. The module can extend 1.10 in. further back in the region that is no more than 3.1 in. from the top edge of the module. Because the metal connector does not have a large extraction force, you should mechanically secure the module to the chassis by using the top and bottom front-threaded strips.

Connector Position

The SCXIBus connector can be two 4x6 right-angle female metal connectors or one 4 x 24-pin right-angle female metal connector.

Table 1 shows the manufacturer part numbers National Instruments uses for the right-angle female metal connectors.

Table 1. Right-Angle Female Metal Connector Part Numbers

Size	Manufacturer	Part Number
4 x 6	DuPont	70268-901
4 x 24	DuPont	70270-901

Threaded Strip Holes

To secure a module to the chassis, use the threaded strips located on the front of the chassis and the two threaded strips on the rear of the chassis. The strips have 2.5 mm tapped holes on 0.2 in. spacing. The centers of these holes are 0.211 in. from the top and bottom edges of the module, and 0.20 in. from the top side of the module. A module can also use the holes that are 0.40 in., 0.60 in., and -0.06 in. from the top side of the module. The other two positions are reserved for set screws that secure the threaded strips to the chassis. The front and rear edges of the module coincide with the lip (the two flat spots on either side of a threaded strip) of the chassis.

Airflow Region

Airflow to the modules comes through a 0.5 in. by 0.95 in. hole in the backplane. Figure 1 shows the extent of this hole. If a module is dissipating more than a couple of watts of power, be sure that airflow is not inhibited. Air should circulate through the module and exit through the rear connector space.

SCXIBus Connector

The SCXIBus connector supplies power to the module. It also supplies access to the digital bus, analog buses, trigger lines, and selection signals. The SCXIBus connector is a subset of the 96-pin male metal header. Only the top and bottom 24 pins are used. The functions of the middle 48 pins are reserved for future products. A module uses a right-angle female metal connector for the mating connector. You can use either a 96-pin connector or two appropriately placed 24-pin connectors. Figure 2 shows the pin assignment of the SCXIBus connector.

GUARD	A1	D1	GUARD
GUARD	B1	C1	GUARD
GUARD	A2	D2	GUARD
AB0+	B2	C2	AB0-
GUARD	A3	D3	GUARD
GUARD	B3	C3	GUARD
GUARD	A4	D4	GUARD
AB1+	B4	C4	AB1-
GUARD	A5	D5	GUARD
GUARD	B5	C5	GUARD
GUARD	A6	D6	GUARD
AB2+	B6	C6	AB2-
RSVD	A7	D7	RSVD
RSVD	B7	C7	RSVD
RSVD	A8	D8	RSVD
RSVD	B8	C8	RSVD
RSVD	A9	D9	RSVD
RSVD	B9	C9	RSVD
RSVD	A10	D10	RSVD
RSVD	B10	C10	RSVD
RSVD	A11	D11	RSVD
RSVD	B11	C11	RSVD
RSVD	A12	D12	RSVD
RSVD	B12	C12	RSVD
RSVD	A13	D13	RSVD
RSVD	B13	C13	RSVD
RSVD	A14	D14	RSVD
RSVD	B14	C14	RSVD
RSVD	A15	D15	RSVD
RSVD	B15	C15	RSVD
RSVD	A16	D16	RSVD
RSVD	B16	C16	RSVD
RSVD	A17	D17	RSVD
RSVD	B17	C17	RSVD
RSVD	A18	D18	RSVD
RSVD	B18	C18	RSVD
RESET*	A19	D19	INTR*
MISO	B19	C19	D*/A
V-	A20	D20	V-
V-	B20	C20	V-
CGND	A21	D21	CGND
CGND	B21	C21	CGND
V+	A22	D22	V+
V+	B22	C22	V+
+5 V	A23	D23	+5 V
SPICLK	B23	C23	MOSI
TRIG0	A24	D24	TRIG1
SS*	B24	C24	SCANCON

Figure 2. SCXI Chassis SCXibus Connector Pin Assignment

SCX1bus Connector Signal Descriptions

Pin	Signal Name	Description
B2	AB0+	Analog Bus 0+ —Positive analog bus 0 line.
C2	AB0–	Analog Bus 0– —Negative analog bus 0 line.
B4	AB1+	Analog Bus 1+ —Positive analog bus 1 line.
C4	AB1–	Analog Bus 1– —Negative analog bus 1 line.
B6	AB2+	Analog Bus 2+ —Positive analog bus 2 line.
C6	AB2–	Analog Bus 2– —Negative analog bus 2 line.
A1, B1, C1, D1, A2, D2, A3, B3, C3, D3, A4, D4, A5, B5, C5, D5, A6, D6	GUARD	Guard—Connect to one guard that shields and guards the analog bus lines from noise.
A19	RESET*	Reset—Control signal activated by the reset button on the front panel of Slot 0.
B19	MISO	Master-In-Slave-Out—One of two data lines on the digital bus. Used as data input by the master.
C19	D*/A	Data/Address—Used by the master to indicate to the slave the type of information that is being sent.
D19	INTR*	Interrupt—Active low. Causes data that is on MOSI to be written to the Slot-Select Register in Slot 0.
A20, B20, C20, D20	V–	Negative Analog Supply— –18.5 to –25 V.
A21, B21, C21, D21	CGND	Chassis Ground—Digital and analog ground reference.
A22, B22, C22, D22	V+	Positive Analog Supply— +18.5 to +25 V.
A23, D23	+5 V	+5 VDC Source—Digital power supply.
B23	SPICLK	Serial Peripheral Interface (SPI) Clock—Clocks the serial data on the MOSI and MISO lines.
C23	MOSI	Master-Out-Slave-In—One of two data lines on the digital bus. Used as data input by the slave.

Pin	Signal Name	Description
A24	TRIG0	TRIG0—General-purpose trigger line. Also used to send a clock signal to Slot 0 and other modules during hardware scanning.
B24	SS*	Slot Select—Indicates to a module that it has been selected as the slave.
C24	SCANCON	Scanning Control—Real-time selection line, typically used in module multiplexing to determine which module is being accessed in a scanned data acquisition.
D24	TRIG1	TRIG1—General-purpose trigger line.
* Indicates active low.		

All other pins are reserved for future use.

Electrical Requirements

Power Requirements

The V+, V–, and +5 V pins supply power to a module. Table 2 shows the specifications for the V+, V–, and +5 V lines.

Table 2. Power Specifications

Supply	Range	Ripple
V+	18.5 to 25 V	1.5 V peak-to-peak
V–	–18.5 to –25 V	1.5 V peak-to-peak
+5 V	4.75 to 5.25 V	50 mV peak-to-peak

All voltages are referenced to chassis ground.

Table 3 shows the current ratings for the SCXI-1000, SCXI-1000DC, and SCXI-1001 chassis.

Table 3. Supply Ratings

Supply	Current Rating		
	SCXI-1000	SCXI-1000DC	SCXI-1001
V+	680 mA	1.00 A	2.04 A
V–	680 mA	860 mA	2.04 A
+5 V	200 mA	1.60 A	600 mA

This averages to 170 mA of V+ and V– per slot and 50 mA of +5 V per slot for the SCXI-1000 and SCXI-1001 and 250 mA of V+, 215 mA of V– and 400 mA of +5 V for the SCXI-1000DC. A slot can use more than its share of the current, and it may use all of the available power. The total current rating for the chassis should not be exceeded, however. Due to thermal considerations, it is recommended that the modules should not dissipate more than 9 W. The current rating for the metal connector is 1 A per pin. Designers of high-power modules should be careful not to exceed this rating. Keep in mind that the current does not distribute itself equally among all pins. Use all four V+, V–, and CGND pins.

The V+ and V– supplies are fused on the backplane at 1 1/2 A on the SCXI-1000, at 2 A on the SCXI-1000DC, and at 4 A on the SCXI-1001. Fuse modules, especially experimental modules, at a lower current value appropriate to their expected current draw. For procedures on backplane fuse testing and replacement, refer to Chapter 2, *Configuration and Installation of the SCXI-1000/1000DC/1001 User Manual*.

Analog Buses and Guard

The three analog buses are connected to all modules, but not Slot 0. The analog buses are differential traces that any module can use to send or receive analog signals. The buses are shielded or guarded by the guard trace, which surrounds all the analog buses. The guard is floating on the backplane, so one module should tie it to a reference voltage, typically grounding it. No arbitration scheme exists for the analog bus, so you should output-protect to ± 25 V any module that drives the bus.

Open-Collector Lines

The two trigger buses, TRIG0 and TRIG1, and the digital bus signals, MOSI, MISO, SPICLK, D*/A, and INTR*, are open-collector lines. On the SCXI-1000, the open-collector lines are pulled up on the backplane to +5 V with 2.2 k Ω resistors. On the SCXI-1001 chassis, the open-collector lines are pulled up on the backplane to +5 V with 1.2 k Ω resistors.

Open-collector or open-drain drivers, like the HCT05 and HCT03 chips, must drive the open-collector lines. A module should have a capacitive load of no more than 20 pF on these lines.

Because the open-drain drivers do not drive the lines high, rise times can be slow—up to 250 ns of delay for a gate threshold of 2 V. Slow edges can cause multiple transitions caused by noise pickup if you use normal gates to receive these lines. Therefore, a module using these lines as inputs should buffer each line with a schmidt trigger gate and keep the trace length from the SCXIbus connector to the gate under 2 in., avoiding close parallel paths with other digital traces. The delay caused by the rising edge varies with the system configuration and threshold levels of specific gates. Therefore, you should use only the falling edge of the trigger lines for critical timing functions.

Module drive requirements referenced to CHSGND are as follows:

- V_{OL} volts, output low 0.4 V max
- I_{in} input current at V_{OL} 5 mA max

HCT Input Lines

SS*, SCANCON, and RESET* are high-speed CMOS TTL (HCT) totem pole lines driven by Slot 0 and used as inputs by modules. SS* and SCANCON are unique to each module—for example, an SCXI-1000 chassis has four SS* and SCANCON lines. One line buses RESET* to all modules.

- A module may place up to 10 transistor-transistor logic (TTL) loads each on the SS* and SCANCON lines.
- A module may place 1 TTL load on the RESET* line.

Digital output specifications of Slot 0, referenced to CHSGND:

- V_{OH} volts, output high 3.7 V min at 4 mA max
- V_{OL} volts, output low 0.4 V max at 4 mA max

Timing Requirements and Specifications

This section describes the timing requirements and specifications for the SCXIbus signals.

RESET* Timing Requirements and Specifications

The RESET* signal shifts from low to high shortly after power up. Whenever you press the Reset Button on the front panel of Slot 0, the RESET* signal will be low. Within 10 μ s after the rising edge of RESET*, the Module ID should be readable.

Digital Bus Timing Requirements and Specifications

This section describes the timing requirements and specifications for the digital bus communications signals.

Overview

Communication over the digital bus involves two parties. On the SCXI chassis, the master is a module and the slave is either another module or Slot 0. (Future SCXI chassis may only allow Slot 0 to be a master. In this case, Slot 0 would have a communications port—RS-232, GPIB, and so on.) The master module controls the INTR* and D*/A lines, supplies a serial clock on the SPICLK line, and supplies data to the slave on the MOSI line. The slave uses its SS* line, or INTR* line in the case of the Slot-Select Register, to determine incoming communications. It monitors the D*/A line to determine whether the information being sent on MOSI is a chip address or data. The slave may also send data back to the master through the MISO line, clocked by the master supplied SPICLK.

MOSI is an open-collector line that carries the data from the master module to either Slot 0 or a slave module.

MISO is an open-collector line that carries the data from the slave module to the master module. Notice that Slot 0 does not write information to this line, so during writes to Slot 0, the MISO line is always high.

SPICLK is an open-collector line that is driven by the master to clock the data on both the MOSI and MISO lines.

INTR* is an open-collector line that is driven by the master. When driven low, all SS* lines become inactive and the data on the MOSI line is written to the Slot-Select Register in Slot 0. The value written to the Slot-Select Register determines which module SS* line becomes active when the master releases INTR* high again. In the case of the SCXI-1001, the value written to the Slot-Select Register is also checked against the chassis address. If the numbers do not match, no SS* line becomes active when the master releases INTR*.

D*/A is an open-collector line that is driven by the master. When driven low, D*/A indicates to a module that information on MOSI is data. When driven high, D*/A indicates that information on MOSI is address information.

The SCXIbus connector provides access to these lines. To be a master, a module must be able to control the lines itself, or it needs to be cabled to something with a digital port that can supply the appropriate signals. You must convert the digital port signals to open-collector on the module to avoid overloading the open-collector backplane lines.

MOSI, MISO, and SPICLK Timing

SPICLK is an idle high-clock signal. When SPICLK falls low, this signals to the slave that the master is putting out data on MOSI. A low SPICLK signal also indicates that the slave should get data ready on the MISO line for the master to read. When SPICLK rises again, the master reads the MISO line, and the slave reads the data present on the MOSI line. Figure 3 shows the timing requirements for the master and slave.

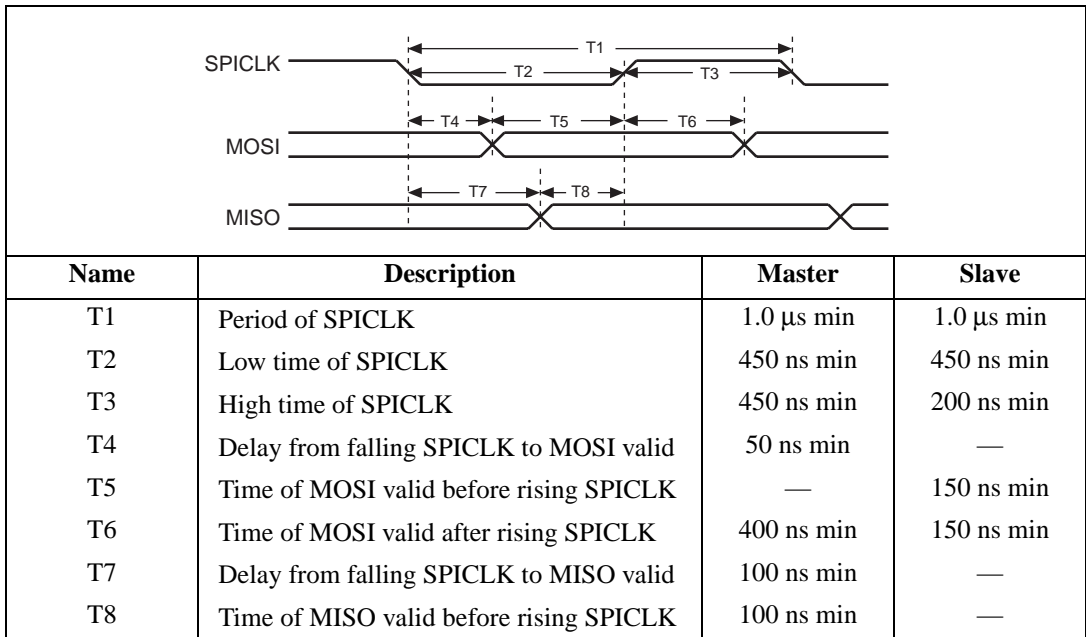

Figure 3. Master and Slave Timing Diagram

A slave maintains its MISO state until a new falling edge on SPICLK occurs. In addition, a slave must stop driving MISO low within 100 ns after Slot 0 disables SS*.

Slot-Select Procedure

For a master to talk to another module, activate the module SS* line by writing a slot-select number to the Slot-Select Register in Slot 0. The INTR* line is like a SS* line for the Slot-Select Register. When INTR* is pulled low by the master, Slot 0 disables all SS* lines to all modules and reads any data clocked on the MOSI line into the Slot-Select Register. Data written to the Slot-Select Register is 16 bits long. After the 16 bits have been written, the master module releases INTR* high, causing Slot 0 to assert the SS* line of the specified slot. On the SCXI-1001, Slot 0 asserts SS* only if the chassis number determined by the jumper settings and the chassis number written to the Slot-Select Register match. This procedure follows and corresponds to the timing diagram in Figure 4, which illustrates the case of selecting Slot 11 in Chassis 9.

- Initial conditions:
 - MOSI = don't care
 - D*/A = don't care
 - INTR* = high
 - SPICLK = high
- Pull INTR* low to deassert all SS* lines to all modules.
- Release D*/A high.

4. For each bit, starting with the most significant bit (MSB) first (bit 15), perform the following steps:
 - a. MOSI = bit to be sent. These bits are the data that is being written to the Slot-Select Register.
 - b. Pull SPICLK low.
 - c. Release SPICLK high. This rising edge clocks the data.
5. Release INTR* high to assert the SS* line of the module whose slot number was written to Slot 0. When no communications are taking place, write zero to the Slot-Select Register to prevent accidental writes.

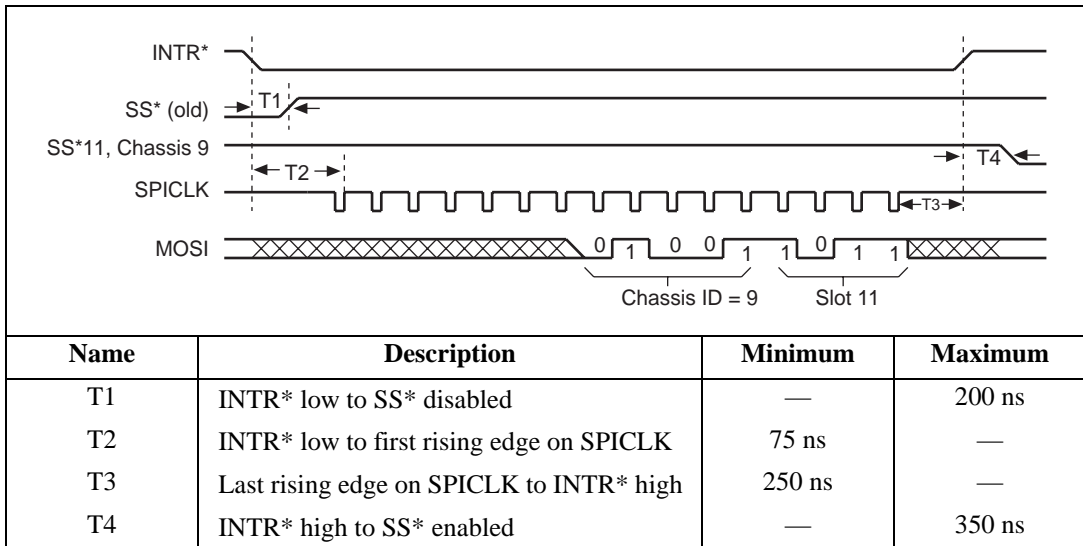

Figure 4. Slot-Select Timing Diagram

Writes to Slot 0 Registers

In addition to the Slot-Select Register, there are two other registers in Slot 0. They are the Hardscan Control Register (HSCR) and the first-in-first-out (FIFO) Register. These registers are used to program Slot 0 to help control scanning operations. Refer to your SCXI chassis register-level programmer manual for register descriptions; for a discussion regarding timing requirements on the scanning operations, see the *SCANCON Timing Requirements and Specifications* section of your SCXI chassis register-level programmer manual.

To write to the HSCR or the FIFO Register, perform the steps below. See Figure 5 for timing specifications.

1. If you are writing to the HSCR, select Slot 13 by following the Slot-Select Procedure. If you are writing to the FIFO Register, select Slot 14 by following the Slot-Select Procedure.
2. For each bit, starting with the MSB first (bit 7 for the HSCR, bit 15 for the FIFO Register), perform the following steps:
 - a. MOSI = bit to be sent.
 - b. Pull SPICLK low.
 - c. Release SPICLK high. This rising edge clocks the data.
3. Pull INTR* low to latch the register data, and establish conditions for writing a new slot-select number to the Slot-Select Register.
4. If you do not select another slot, write zero to the Slot-Select Register. If you do select another slot, start at step 4 of the previous section, *Slot-Select Procedure*.

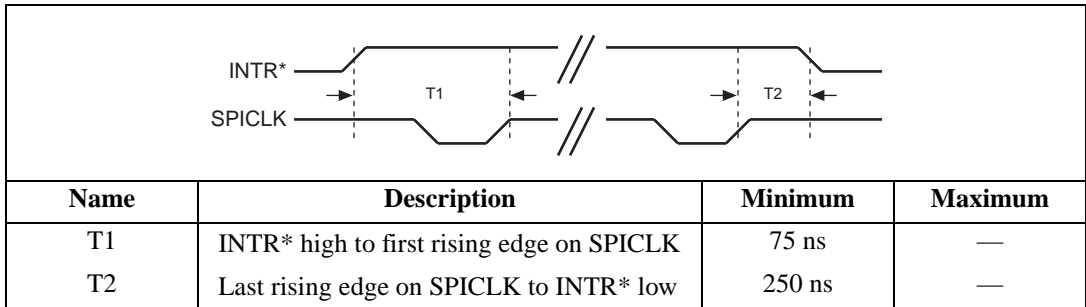

Figure 5. Slot 0 Register Writes Diagram

Module Types and Communication Protocols

There are two types of modules from a communication point of view—those with an address handler, and those without an address handler.

Class I Modules

A class I module contains two registers, a Configuration Register that receives data on the MOSI line, and a Module ID Register that puts out data on the MISO line. The Configuration Register may be any number of bits; you should, however, limit the bit length to 32 bits. If more are needed, split the bits into multiple configuration registers and make the module a class II module. The Module ID Register must be four bytes long. The Module ID Register must clock data out, MSB first for each byte, and send the least significant byte first. For example, a Module ID of 384 would be sent as 10000000 00000001 00000000 00000000, where the first 1 is the first bit sent.

The Configuration Register should receive data only when SS* is low and D*/A is low. The Module ID Register should clock out data when SS* is low, independent of the state of D*/A.

After the four bytes of Module ID have been sent out, the module may send out erroneous data. Deasserting the SS* line high should cause the Module ID Register to reinitialize. Figure 6 shows the class I module structure.

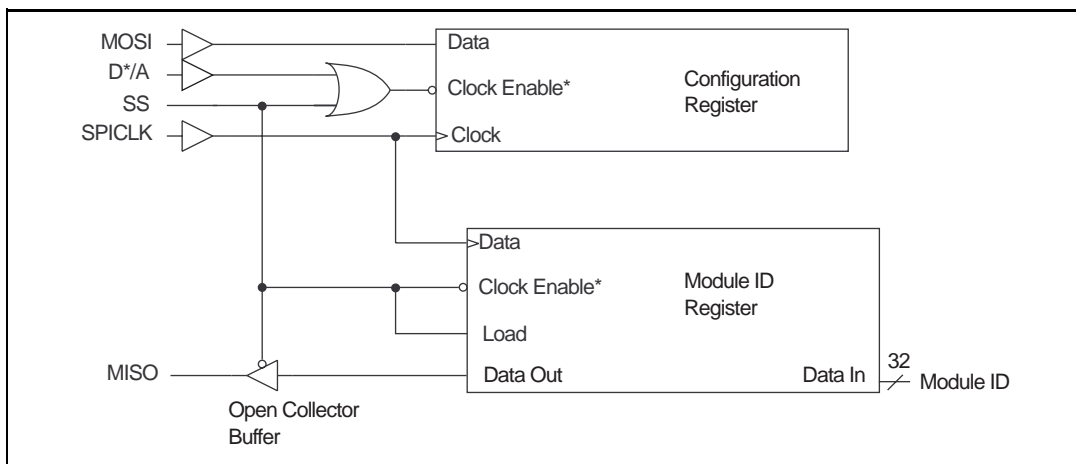

Figure 6. Class I Module Structure Diagram

To write to a class I module Configuration Register, follow the steps below. Refer to Figure 7 for timing specifications.

1. Select the slot of the desired module following the *Slot-Select Procedure* earlier in this document.
2. Pull D*/A low to write data to the Configuration Register.
3. For each bit to be written, perform the following steps:
 - a. MOSI = bit to be sent.
 - b. Pull SPICLK low.
 - c. Release SPICLK high. This rising edge clocks the data.
4. Pull INTR* low to deassert the SS* line and establish conditions for writing a new slot-select number to the Slot-Select Register.
5. If you do not select another slot, you should write zero to the Slot-Select Register. If you do select another slot, start at step 4 of the *Slot-Select Procedure* earlier in this document.

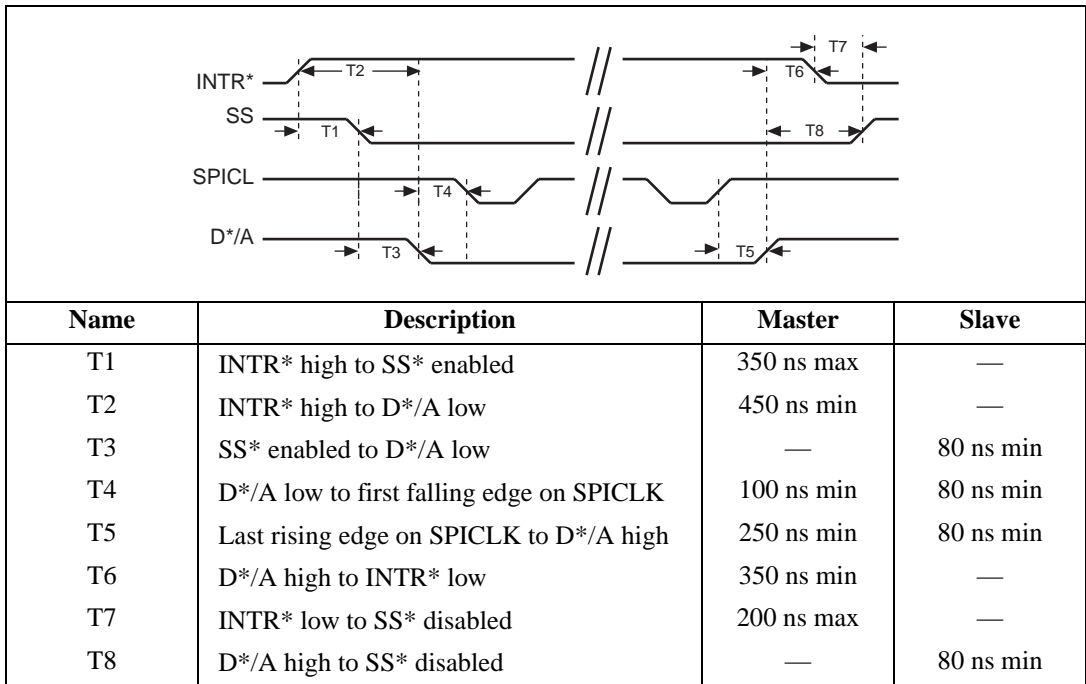

Figure 7. Class I Timing Diagram

Class II Modules

A class II module has an address handler, a 16-bit register that is written to when D*/A is high and SS* is low. The address in the address handler indicates which of 65,536 possible locations on the module will be accessed by the master when the D*/A line is low, indicating a data write instead of an address write. The address handler should be constructed so that if more than 16 bits are written, the leading bits are thrown out and the address handler only retains the last 16 bits.

A class II module must have a Module ID Register located at address zero. The Module ID Register must be four bytes long. Data must be clocked out MSB first for each byte, with the least significant byte being sent first. For example, a Module ID of 384 would be sent as 10000000 00000001 00000000 00000000, where the first 1 is the first bit sent.

The Module ID Register should clock out data when it is selected by the address handler. After the four bytes of the Module ID have been sent out, the Module ID Register may send out erroneous data. Deselection by the address handler should cause the Module ID Register to reinitialize. Locations accessed by the address handler can be of many varieties; Registers, EEPROMs, microcontrollers, and so on. When a peripheral is a simple register whose information must also be stored in memory on a remote computer, the register should be limited to 32 bits in length. Figure 8 shows the class II module structure.

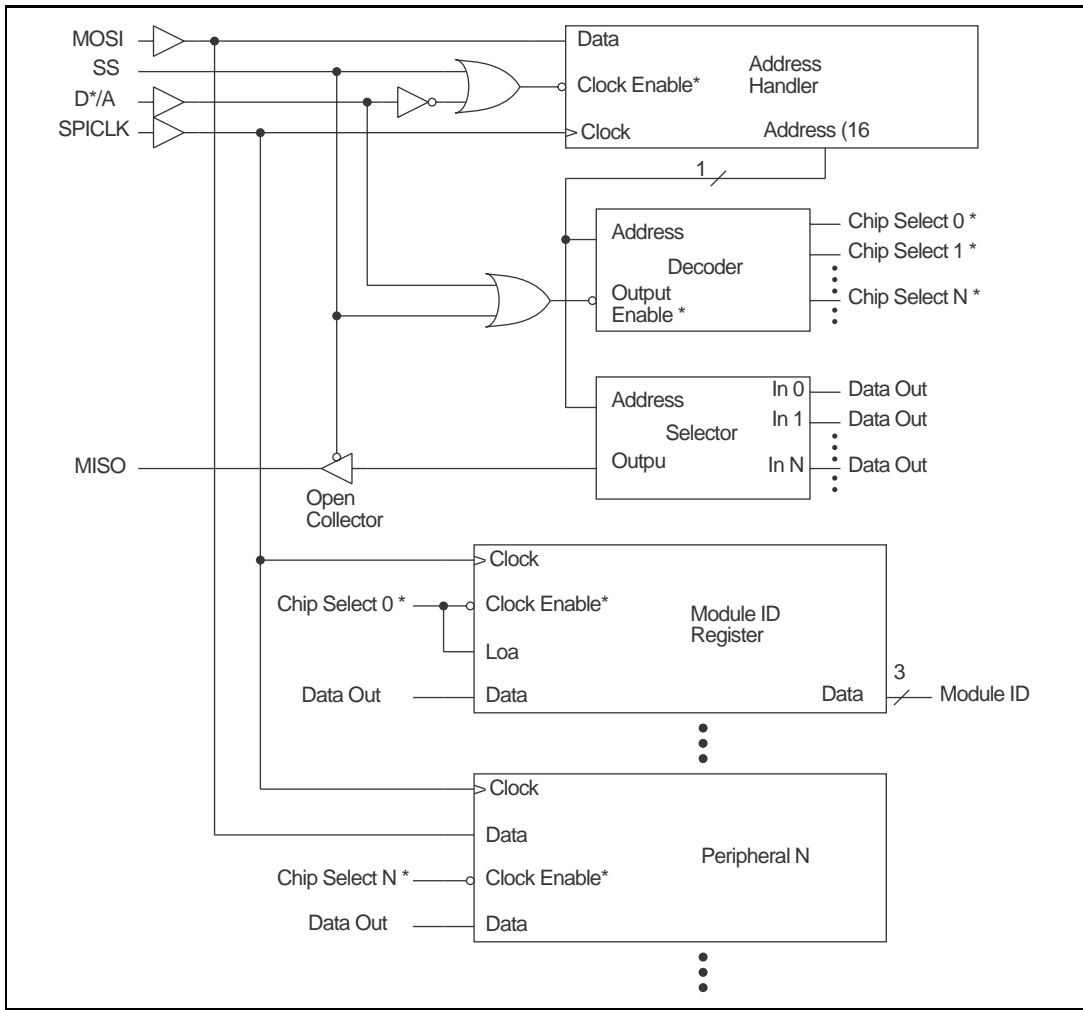

Figure 8. Class II Module Structure Diagram

To communicate with a class II module, perform the steps below. Refer to Figure 9 for timing specifications.

1. Select the slot of the desired module following the *Slot-Select Procedure* earlier in this document.
2. Write the 16-bit address of the peripheral to the class II module with which communications will take place. For each address bit, MSB first, perform the following steps:
 - a. MOSI = bit to be sent.
 - b. Pull SPICLK low.
 - c. Release SPICLK high. This rising edge clocks the data.

3. Pull D*/A low to indicate that data will be transmitted instead of an address. Notice that depending on the complexity of the peripheral, some of the *data* information that is sent may be address information for the peripheral. However, the chassis does not know this and so this information is still referred to as *data*.
4. Communicate with the peripheral. The specifics of how this is done depends on the peripheral. Some peripherals may have simple registers like the Configuration Register in a class I module, whereas others may be EEPROMs or microcontrollers with more elaborate protocols.
5. To talk to a different peripheral on the same slot, release D*/A high and proceed from step 2 of this section. To talk to a different module, start at step 1 of this section or step 1 of the section, *Class I Modules*, whichever is appropriate.

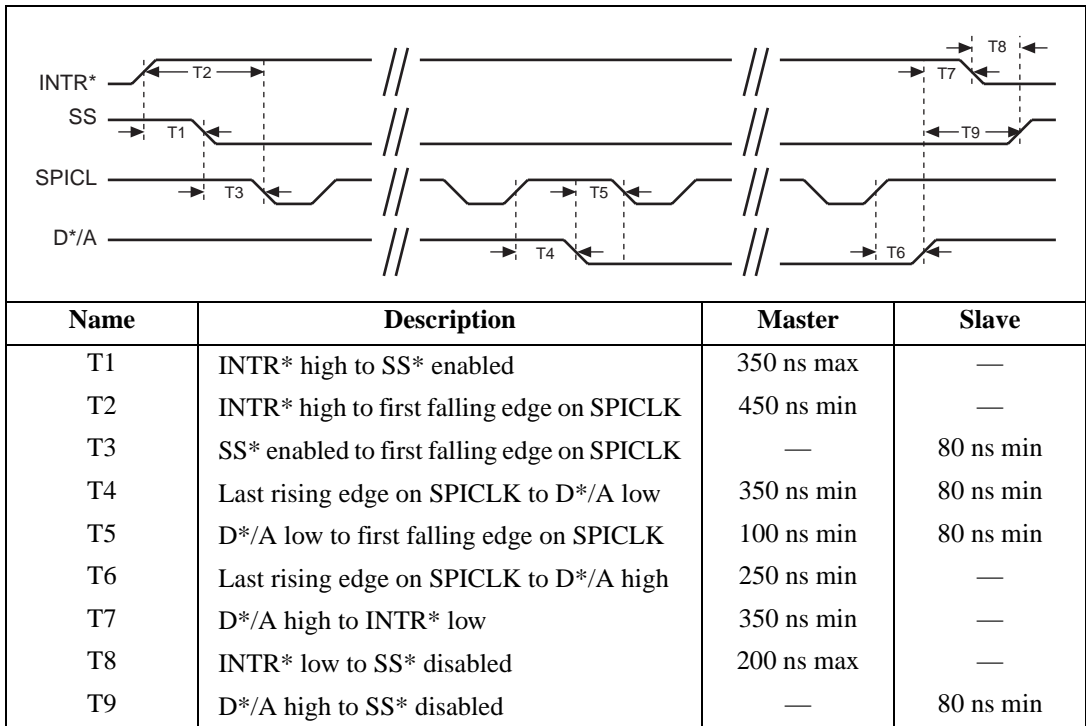

Figure 9. Class II Timing Diagram

Module ID Protocol

The procedure for reading the Module ID of a slot follows. Before reading the ID, it is not known whether the module is class I or class II. The timing specifications for this procedure are equivalent to those discussed in the previous section, *Class II Modules*.

1. Select the slot of the desired module following the *Slot-Select Procedure* earlier in this document.
2. Write 32 zeros to the module and read the Module ID that is present on the MISO line.
3. If the Module ID is all ones, go to step 4; otherwise, you have read the Module ID of a class I module and should go to step 7.
4. Pull D*/A low.
5. Write 32 bits of anything to the module and read the Module ID that is present on the MISO line.
6. If the Module ID was all ones, the slot is empty. Otherwise, you have read the Module ID of a class II module.
7. Deselect the slot.

SCANCON Timing Requirements and Specifications

Slot 0 contains timing circuitry that you can use to choose one module at a time during a scanning operation. Program the FIFO Register and HSCR to set up a scan list. This scan list is a list of modules, and for each entry, a count to indicate how long the module is selected. After you program Slot 0, the slot that corresponds to the first entry is *chosen*, meaning that its SCANCON pin is active or low. Slot 0 counts falling edges on TRIG0. After the number of falling edges on TRIG0 matches the count for the current scan list entry, the next entry becomes active, and the SCANCON for that module is asserted.

The timing relations between TRIG0 and SCANCON follows. For more information on the programming operation of the hardscan circuitry, refer to the SCXI chassis user manual.

There are two different modes of SCANCON operation from a timing point of view. In one case, there is a gap between the switching of the SCANCON signals. This mode is useful for two reasons:

- First, if consecutive scan list entries are for the same module, the SCANCON line pulses high between entries, indicating to the module that the scan list has advanced an entry.
- Second, when modules that are multiplexing their outputs to the analog bus use the hardscan circuitry as an enable signal, the gap ensures that during switching, two modules do not simultaneously drive the bus. This situation could easily occur if different modules have switches with different delay times. If you output-protect the outputs of the drivers, no damage occurs, but the driver contention could make an amplifier oscillate or ring, thus producing bad results.

In the other case, there is no gap between transitions, and if consecutive scan list entries are for the same module, SCANCON remains low between the transition. Use this mode when it is necessary to hold SCANCON low for more than the 128 counts that is the maximum for a

scan list entry. Notice that in this case, to get SCANCON to go high on one module, you need an entry for a different module. On the SCXI-1000, FIFO Register entries can be for only one of the four slots. On the SCXI-1001, FIFO Register entries can be for a dummy slot, so that no SCANCON is asserted. Figure 10 shows the timing for the SCANCON and TRIG0 signals.

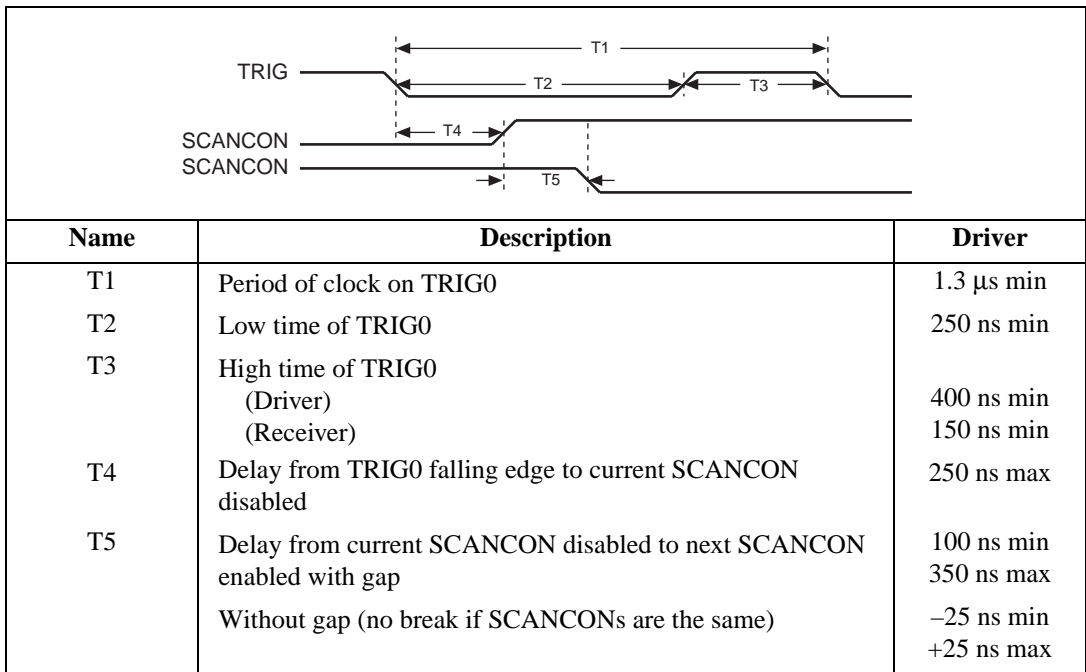

Figure 10. SCANCON and TRIG0 Timing Diagram



Note

Driver refers to the module that drives TRIG0, and Receiver refers to any other module that is listening to TRIG0.