

SCXI-1100

User Manual

32-Channel Differential Multiplexer/Amplifier Module for Signal Conditioning

October 1994 Edition

Part Number 320637C-01

**© Copyright 1991, 1994 National Instruments Corporation.
All Rights Reserved.**

National Instruments Corporate Headquarters

6504 Bridge Point Parkway

Austin, TX 78730-5039

(512) 794-0100

Technical support fax: (800) 328-2203

(512) 794-5678

Branch Offices:

Australia (03) 879 9422, Austria (0662) 435986, Belgium 02/757.00.20, Canada (Ontario) (519) 622-9310,

Canada (Québec) (514) 694-8521, Denmark 45 76 26 00, Finland (90) 527 2321, France (1) 48 14 24 24,

Germany 089/741 31 30, Italy 02/48301892, Japan (03) 3788-1921, Mexico 95 800 010 0793,

Netherlands 03480-33466, Norway 32-84 84 00, Singapore 2265886, Spain (91) 640 0085, Sweden 08-730 49 70,

Switzerland 056/20 51 51, Taiwan 02 377 1200, U.K. 0635 523545

Limited Warranty

The SCXI-1100 is warranted against defects in materials and workmanship for a period of one year from the date of shipment, as evidenced by receipts or other documentation. National Instruments will, at its option, repair or replace equipment that proves to be defective during the warranty period. This warranty includes parts and labor.

A Return Material Authorization (RMA) number must be obtained from the factory and clearly marked on the outside of the package before any equipment will be accepted for warranty work. National Instruments will pay the shipping costs of returning to the owner parts which are covered by warranty.

National Instruments believes that the information in this manual is accurate. The document has been carefully reviewed for technical accuracy. In the event that technical or typographical errors exist, National Instruments reserves the right to make changes to subsequent editions of this document without prior notice to holders of this edition. The reader should consult National Instruments if errors are suspected. In no event shall National Instruments be liable for any damages arising out of or related to this document or the information contained in it.

EXCEPT AS SPECIFIED HEREIN, NATIONAL INSTRUMENTS MAKES NO WARRANTIES, EXPRESS OR IMPLIED, AND SPECIFICALLY DISCLAIMS ANY WARRANTY OF MERCHANTABILITY OR FITNESS FOR A PARTICULAR PURPOSE. CUSTOMER'S RIGHT TO RECOVER DAMAGES CAUSED BY FAULT OR NEGLIGENCE ON THE PART OF NATIONAL INSTRUMENTS SHALL BE LIMITED TO THE AMOUNT THERETOFORE PAID BY THE CUSTOMER. NATIONAL INSTRUMENTS WILL NOT BE LIABLE FOR DAMAGES RESULTING FROM LOSS OF DATA, PROFITS, USE OF PRODUCTS, OR INCIDENTAL OR CONSEQUENTIAL DAMAGES, EVEN IF ADVISED OF THE POSSIBILITY THEREOF. This limitation of the liability of National Instruments will apply regardless of the form of action, whether in contract or tort, including negligence. Any action against National Instruments must be brought within one year after the cause of action accrues. National Instruments shall not be liable for any delay in performance due to causes beyond its reasonable control. The warranty provided herein does not cover damages, defects, malfunctions, or service failures caused by owner's failure to follow the National Instruments installation, operation, or maintenance instructions; owner's modification of the product; owner's abuse, misuse, or negligent acts; and power failure or surges, fire, flood, accident, actions of third parties, or other events outside reasonable control.

Copyright

Under the copyright laws, this publication may not be reproduced or transmitted in any form, electronic or mechanical, including photocopying, recording, storing in an information retrieval system, or translating, in whole or in part, without the prior written consent of National Instruments Corporation.

Trademarks

LabVIEW[®], NI-DAQ[®], and RTSI[®] are trademarks of National Instruments Corporation.

Product and company names listed are trademarks or trade names of their respective companies.

WARNING REGARDING MEDICAL AND CLINICAL USE OF NATIONAL INSTRUMENTS PRODUCTS

National Instruments products are not designed with components and testing intended to ensure a level of reliability suitable for use in treatment and diagnosis of humans. Applications of National Instruments products involving medical or clinical treatment can create a potential for accidental injury caused by product failure, or by errors on the part of the user or application designer. Any use or application of National Instruments products for or involving medical or clinical treatment must be performed by properly trained and qualified medical personnel, and all traditional medical safeguards, equipment, and procedures that are appropriate in the particular situation to prevent serious injury or death should always continue to be used when National Instruments products are being used. National Instruments products are NOT intended to be a substitute for any form of established process, procedure, or equipment used to monitor or safeguard human health and safety in medical or clinical treatment.

Contents

About This Manual	xi
Organization of This Manual	xi
Conventions Used in This Manual	xii
Related Documentation	xiii
Customer Communication	xiii
Chapter 1	
Introduction	1-1
What Your Kit Should Contain	1-1
Optional Software	1-2
Optional Equipment	1-3
Custom Cables	1-4
Unpacking	1-4
Chapter 2	
Configuration and Installation	2-1
Module Configuration	2-1
Digital Signal Connections	2-3
Jumper W5	2-3
Jumper W9	2-4
Using Jumpers W5 and W9	2-4
Jumper W11 (Revision A and B Modules Only)	2-4
Analog Configuration	2-5
Grounding, Shielding, and Output Mode Selection	2-6
Jumper W10	2-6
Reference Mode Selection	2-7
Jumper W1	2-7
Filter Selection	2-7
Jumpers W2 through W4	2-7
Output Selection	2-8
Jumpers W7 and W8	2-8
Input Filtering and Current Loop Receivers	2-9
Hardware Installation	2-10
Signal Connections	2-11
Front Connector	2-11
Front Connector Signal Descriptions	2-13
Analog Input Channels	2-13
Thermocouple Connections	2-16
Open Thermocouple Detection	2-17
Analog Output	2-17
Connector-and-Shell Assembly	2-17
SCXI-1300 Terminal Block	2-19
Terminal Block Temperature Sensor	2-19
Terminal Block Jumper Configuration	2-19
Terminal Block Signal Connection	2-20
Terminal Block Installation	2-20
Rear Signal Connector	2-22
Rear Signal Connector Signal Descriptions	2-23

Analog Output Signal Connections.....	2-24
Digital I/O Signal Connections	2-24
Timing Requirements and Communication Protocol.....	2-26
Timing Signal.....	2-26
Communication Signals	2-26

Chapter 3

Theory of Operation	3-1
Functional Overview	3-1
SCXIbus Connector	3-3
SCXIbus Connector Signal Descriptions	3-5
Digital Interface Circuitry	3-7
Digital Control Circuitry	3-8
Analog and Timing Circuitry	3-9
Analog Input and Timing Circuits	3-9
Calibration.....	3-12
Analog Output Circuitry	3-13
Scanning Modes	3-14
Single-Module Multiplexed Scanning	3-14
Single-Module Multiplexed Scanning (Direct).....	3-14
Single-Module Multiplexed Scanning (Indirect)	3-15
Multiple-Module Multiplexed Scanning.....	3-15
Multiple-Chassis Scanning	3-16

Chapter 4

Register Descriptions	4-1
Register Description.....	4-1
Register Description Format	4-1
SCXI-1100 Register Descriptions.....	4-1
Module ID Register.....	4-2
Configuration Register	4-3
Slot 0 Register Descriptions.....	4-6
Slot-Select Register.....	4-7
Hardscan Control Register (HSCR).....	4-8
FIFO Register.....	4-9

Chapter 5

Programming.....	5-1
Programming Considerations.....	5-1
Notation.....	5-1
Register Writes.....	5-1
Register Selection and Write Procedure	5-2
Initialization	5-3
Single-Channel Measurements	5-3
Direct Measurements	5-3
Indirect Measurements	5-4
Measurements from Other Modules	5-4
Measurements from the SCXI-1100 via Another Module.....	5-4
Scanning Measurements	5-5
1. Data Acquisition Board Setup Programming.....	5-6
Counter 1 and SCANDIV	5-7
2. Module Programming	5-8
Single-Module Multiplexed Scanning (Direct).....	5-8

Single-Module Multiplexed Scanning (Indirect)	5-8
Channel Scanning from Other Modules.....	5-8
Channel Scanning from the SCXI-1100 via Another Module	5-8
Multiple-Module Multiplexed Scanning.....	5-9
Multiple-Chassis Scanning	5-9
3. Programming the Slot 0 Hardscan Circuitry	5-10
4. Acquisition Enable, Triggering, and Servicing.....	5-11
Scanning Examples	5-11
Example 1	5-11
Example 2	5-12
Example 3	5-13
Appendix A	
Specifications	A-1
Analog Input	A-1
Explanation of Analog Input Specifications	A-2
Physical	A-3
Cold-Junction Sensor	A-3
Operating Environment.....	A-3
Storage Environment.....	A-3
Appendix B	
Rear Signal Connector	B-1
Rear Signal Connector Signal Descriptions.....	B-2
Appendix C	
SCXIbus Connector	C-1
SCXIbus Connector Signal Descriptions.....	C-3
Appendix D	
SCXI-1100 Front Connector	D-1
Front Connector Signal Descriptions.....	D-2
Appendix E	
SCXI-1100 Cabling	E-1
SCXI-1340 Cable Assembly	E-1
SCXI-1340 Installation	E-2
SCXI-1341 Lab-NB, Lab-PC, or Lab-PC+ and SCXI-1344 Lab-LC Cable Assemblies.....	E-3
SCXI-1341 and SCXI-1344 Installation	E-4
SCXI-1342 PC-LPM-16 Cable Assembly	E-5
SCXI-1342 Installation	E-6
AT-MIO-16D and AT-MIO-64F-5 Board Connection.....	E-6
SCXI-1351 and NB5 Cable Installation.....	E-6
SCXI-1180 Feedthrough Panel	E-8
SCXI-1180 Installation	E-8
SCXI-1302 50-Pin Terminal Block	E-10
SCXI-1302 Wiring Procedure.....	E-10
SCXI-1302 Installation	E-11
SCXI-1351 One-Slot Cable Extender	E-12
SCXI-1351 Installation	E-12

Contents

SCXI-1350 Multichassis Adapter	E-12
SCXI-1350 Installation	E-13
SCXI-1343 Rear Screw Terminal Adapter	E-13
SCXI-1343 Installation	E-13
Appendix F	
Revision A and B Photo and Parts Locator Diagram	F-1
Appendix G	
Customer Communication.....	G-1
Glossary	Glossary-1
Index	Index-1

Figures

Figure 2-1.	SCXI-1100 Parts Locator Diagram	2-2
Figure 2-2.	SCXI-1100 Front Connector Pin Assignment	2-12
Figure 2-3.	Ground-Referenced Signal Connection	2-14
Figure 2-4.	Floating Signal Connection.....	2-14
Figure 2-5.	AC-Coupled Signal Connection.....	2-15
Figure 2-6.	Assembling and Mounting the Connector-and-Shell Assembly	2-18
Figure 2-7.	SCXI-1300 Parts Locator Diagram	2-21
Figure 2-8.	SCXI-1100 Rear Signal Connector Pin Assignment	2-22
Figure 2-9.	SCANCLK Timing Requirements	2-26
Figure 2-10.	Slot-Select Timing Diagram	2-27
Figure 2-11.	Serial Data Timing Diagram	2-28
Figure 2-12.	Configuration Register Write Timing Diagram	2-29
Figure 2-13.	SCXI-1100 Module ID Register Timing Diagram	2-29
Figure 3-1.	SCXI-1100 Block Diagram.....	3-1
Figure 3-2.	SCXI-1100 Detailed Block Diagram	3-2
Figure 3-3.	SCXIbus Connector Pin Assignment	3-4
Figure 3-4.	Digital Interface Circuitry Block Diagram	3-7
Figure 3-5.	SCXI-1100 Digital Control Circuitry	3-8
Figure 3-6.	Analog Input and Timing Block Diagram	3-10
Figure 3-7.	Pad Locations	3-12
Figure 3-8.	Analog Output Circuitry	3-13
Figure 3-9.	Single-Module Multiplexed Scanning (Direct).....	3-15
Figure 3-10.	Single-Module Multiplexed Scanning (Indirect)	3-15
Figure 3-11.	Multiple-Module Multiplexed Scanning.....	3-16
Figure 3-12.	Multiple-Chassis Scanning	3-16
Figure B-1.	SCXI-1100 Rear Signal Connector Pin Assignment	B-1
Figure C-1.	SCXIbus Connector Pin Assignment	C-2
Figure D-1.	SCXI-1100 Front Connector Pin Assignment	D-1
Figure E-1.	SCXI-1340 Installation	E-3
Figure E-2.	NB5 Cable and SCXI-1351 Installation.....	E-7
Figure E-3.	SCXI-1180 Rear Connections.....	E-9
Figure E-4.	SCXI-1180 Front Panel Installation.....	E-10
Figure E-5.	Cover Removal	E-11
Figure F-1.	Revision A and B SCXI-1100 Signal Conditioning Module	F-1
Figure F-2.	Revision A and B SCXI-1100 Parts Locator Diagram	F-2

Tables

Table 2-1.	Digital Signal Connections, Jumper Settings	2-5
Table 2-2.	Jumper W10 Settings	2-6
Table 2-3.	Jumper W1 Settings	2-7
Table 2-4.	Jumpers W2, W3, and W4 Settings	2-8
Table 2-5.	Jumpers W7 and W8 Settings	2-9
Table 2-6.	User-Defined Input Filter Capacitors	2-9
Table 2-7.	User-Defined Current Receiver Resistors	2-10
Table 2-8.	Jumper Setting on the Terminal Block	2-20
Table 2-9.	SCXIbus to SCXI-1100 Rear Signal Connector to Data Acquisition Board Pin Equivalences	2-25
Table 3-1.	SCXIbus Equivalents for the Rear Signal Connector	3-6
Table 3-2.	Multiplexer/Input Channel Correspondence	3-11
Table 5-1.	SCXI-1100 Rear Signal Connector Pin Equivalences	5-2
Table E-1.	SCXI-1100 and MIO Board Pinout Equivalences	E-2
Table E-2.	SCXI-1341 and SCXI-1344 Pin Translations	E-4
Table E-3.	SCXI-1342 Pin Translations	E-5
Table E-4.	SCXI-1343 Pin Connections	E-14

About This Manual

This manual describes the electrical and mechanical aspects of the SCXI-1100 module and contains information concerning its operation and programming. The SCXI-1100 operates as a 32-channel differential input multiplexer with an onboard software-programmable gain instrumentation amplifier (PGIA). The SCXI-1100 is a member of the National Instruments Signal Conditioning eXtensions for Instrumentation (SCXI) Series modules for the National Instruments data acquisition plug-in boards. This module is designed for low-cost signal conditioning of thermocouples, volt sources, millivolt sources, and 4 to 20 mA sources or 0 to 20 mA process-current sources.

This manual describes the installation, theory of operation, and basic programming considerations for the SCXI-1100.

Organization of This Manual

The *SCXI-1100 User Manual* is organized as follows:

- Chapter 1, *Introduction*, describes the SCXI-1100; lists the contents of your SCXI-1100 kit; describes the optional software, optional equipment, and custom cables; and explains how to unpack the SCXI-1100 kit.
- Chapter 2, *Configuration and Installation*, describes the SCXI-1100 jumper configurations, installation of the SCXI-1100 into the SCXI chassis, signal connections to the SCXI-1100, and cable wiring.
- Chapter 3, *Theory of Operation*, contains a functional overview of the SCXI-1100 module and explains the operation of each functional unit making up the SCXI-1100.
- Chapter 4, *Register Descriptions*, describes in detail the SCXI-1100 Module ID Register, the Configuration Register, the Slot 0 registers, and multiplexer addressing.
- Chapter 5, *Programming*, contains a functional programming description of the SCXI-1100 and Slot 0.
- Appendix A, *Specifications*, lists the specifications for the SCXI-1100.
- Appendix B, *Rear Signal Connector*, describes the pinout and signal names for the SCXI-1100 50-pin rear signal connector, including a description of each connection.
- Appendix C, *SCXIBus Connector*, describes the pinout and signal names for the SCXI-1100 96-pin SCXIBus connector, including a description of each connection.
- Appendix D, *SCXI-1100 Front Connector*, describes the pinout and signal names for the SCXI-1100 front connector, including a description of each connection.
- Appendix E, *SCXI-1100 Cabling*, describes how to use and install the hardware accessories for the SCXI-1100.

- Appendix F, *Revision A and B Photo and Parts Locator Diagram*, contains a photograph of the Revision A and B SCXI-1100 and the parts locator diagram.
- Appendix G, *Customer Communication*, contains forms you can use to request help from National Instruments or to comment on our products and manuals.
- The *Glossary* contains an alphabetical list and description of terms used in this manual, including abbreviations, acronyms, metric prefixes, mnemonics, and symbols.
- The *Index* contains an alphabetical list of key terms and topics in this manual, including the page where you can find each one.

Conventions Used in This Manual

The following conventions are used in this manual.

<i>italic</i>	Italic text denotes emphasis, a cross reference, or an introduction to a key concept.
Lab board	Lab board refers to the Lab-LC, Lab-NB, Lab-PC, and Lab-PC+ boards unless otherwise noted.
MC	MC refers to the Micro Channel series computers.
MIO board	MIO board refers to the AT-MIO-16, AT-MIO-16D, AT-MIO-16F-5, AT-MIO-16X, AT-MIO-64F-5, MC-MIO-16, NB-MIO-16, and NB-MIO-16X multichannel I/O data acquisition boards unless otherwise noted.
monospace	Lowercase text in this font denotes text or characters that are to be literally input from the keyboard, sections of code, programming examples, and syntax examples. This font is also used for the proper names of disk drives, paths, directories, programs, subprograms, subroutines, device names, functions, variables, filenames, and extensions, and for statements and comments taken from program code.
NB	NB refers to the NuBus series computers.
PC	PC refers to the IBM PC/XT, the IBM PC AT, and compatible computers.
SCXIbus	SCXIbus refers to the backplane in the chassis. A signal on the backplane is referred to as the SCXIbus <signal name> line (or signal). The SCXIbus descriptor may be omitted when the meaning is clear. Descriptions of all SCXIbus signals are given in Appendix C, <i>SCXIbus Connector</i> .
Slot 0	Slot 0 refers to the power supply and control circuitry in the SCXI chassis.

Abbreviations, acronyms, metric prefixes, mnemonics, symbols, and terms are listed in the *Glossary*.

Related Documentation

The following documents contain information that you may find helpful as you read this manual:

- *AT-MIO-16 User Manual* (part number 320476-01)
- *AT-MIO-16D User Manual* (part number 320489-01)
- *AT-MIO-16F-5 User Manual* (part number 320266-01)
- *AT-MIO-16X User Manual* (part number 320488-01)
- *AT-MIO-64F-5 User Manual* (part number 320487-01)
- *Lab-LC User Manual* (part number 320380-01)
- *Lab-NB User Manual* (part number 320174-01)
- *Lab-PC User Manual* (part number 320205-01)
- *Lab-PC+ User Manual* (part number 320502-01)
- *MC-MIO-16 User Manual, Revisions A to C* (part number 320130-01)
- *MC-MIO-16 User Manual, Revision D* (part number 320560-01)
- *NB-MIO-16 User Manual* (part number 320295-01)
- *NB-MIO-16X User Manual* (part number 320157-01)
- *PC-LPM-16 User Manual* (part number 320287-01)
- *SCXI-1000/1001 User Manual* (part number 320423-01)

Customer Communication

National Instruments wants to receive your comments on our products and manuals. We are interested in the applications you develop with our products, and we want to help if you have problems with them. To make it easy for you to contact us, this manual contains comment and configuration forms for you to complete. These forms are in Appendix G, *Customer Communication*, at the end of this manual.

Chapter 1

Introduction

This chapter describes the SCXI-1100; lists the contents of your SCXI-1100 kit; describes the optional software, optional equipment, and custom cables; and explains how to unpack the SCXI-1100 kit.

The SCXI-1100 module operates as a fast 32-channel differential multiplexer with an onboard programmable gain instrumentation amplifier (PGIA). The SCXI-1100 is a module for signal conditioning of thermocouples, volt sources, millivolt sources, 4 to 20 mA current sources, and 0 to 20 mA process-current sources. If you provide external excitation, you can also measure thermistors, strain gauges, and RTDs.

The SCXI-1100 operates with full functionality with the National Instruments MIO boards. You can use the Lab-LC, Lab-NB, Lab-PC, Lab-PC+, and PC-LPM-16 boards with the SCXI-1100, but these boards can perform only single-channel reads and cannot scan the module. You can also use the SCXI-1100 with other systems that comply with the specifications given in Chapter 2, *Configuration and Installation*. Each SCXI-1100 module multiplexes its 32 input channels into a single channel of the data acquisition board. You can multiplex several SCXI-1100s into a single channel, thus greatly increasing the number of analog input signals that you can digitize.

An additional shielded terminal block has screw terminals for easy signal attachment to the SCXI-1100. In addition, a temperature sensor for cold-junction compensation of thermocouples is included on the terminal block. This cold-junction reference (CJR) is either multiplexed with the 32 channels or jumper connected to a different channel of the data acquisition board.

With the SCXI-1100 module, the SCXI chassis can serve as a fast-scanning signal conditioner for laboratory testing, production testing, and industrial-process monitoring.

What Your Kit Should Contain

The contents of the SCXI-1100 kit (part number 776572-00) are listed as follows.

Kit Component	Part Number
SCXI-1100 module	181690-01
<i>SCXI-1100 User Manual</i>	320637-01

If your kit is missing any of the components, contact National Instruments.

Optional Software

This manual contains complete instructions for directly programming the SCXI-1100. You can order separate software packages for controlling the SCXI-1100 from National Instruments.

When you use the SCXI-1100 in combination with the PC, AT, or MC data acquisition boards with the SCXI-1100, you can use LabVIEW for Windows or LabWindows® for DOS. LabVIEW and LabWindows are innovative program development software packages for data acquisition and control applications. LabVIEW uses graphical programming, whereas LabWindows enhances Microsoft C and QuickBASIC. Both packages include extensive libraries for data acquisition, instrument control, data analysis, and graphical data presentation.

You can use the SCXI-1100, together with the NB Series data acquisition boards, with LabVIEW for Macintosh, a software system that features interactive graphics, a state-of-the-art user interface, and a powerful graphical programming language. The LabVIEW Data Acquisition Virtual Instrument (VI) Library, a series of VIs for using LabVIEW with National Instruments boards, is included with LabVIEW. The LabVIEW Data Acquisition VI Library is functionally equivalent to the NI-DAQ software for Macintosh.

The NI-DAQ driver software is shipped free with National Instruments data acquisition boards. NI-DAQ has a library of functions that you can call from your application programming environment. These functions include routines for analog input (A/D conversion), buffered data acquisition (high-speed A/D conversion), analog output (D/A conversion), waveform generation, digital I/O, counter/timer, SCXI, Real-Time System Integration (RTSI), and self-calibration. NI-DAQ maintains a consistent software interface among its different versions so you can switch between platforms with minimal modifications to your code.

The National Instruments PC, AT, and MC data acquisition boards are packaged with NI-DAQ software for DOS/Windows/LabWindows. NI-DAQ software for DOS/Windows/LabWindows comes with language interfaces for Professional BASIC, Turbo Pascal, Turbo C, Turbo C++, Borland C++, and Microsoft C for DOS; and Visual Basic, Turbo Pascal, Microsoft C with SDK, and Borland C++ for Windows. NI-DAQ software for DOS/Windows/LabWindows is on high-density 5.25 in. and 3.5 in. diskettes. You can use your SCXI-1100, together with your PC, AT, and MC Series data acquisition boards, with NI-DAQ software for DOS/Windows/LabWindows.

The National Instruments NB Series data acquisition boards are packaged with NI-DAQ software for Macintosh. NI-DAQ software for Macintosh comes with language interfaces for MPW C, THINK C, Pascal, and Microsoft QuickBASIC. Any language that uses Device Manager Toolbox calls can access NI-DAQ software for Macintosh. You can use your SCXI-1100, together with the NB Series data acquisition boards, with NI-DAQ software for Macintosh.

Optional Equipment

Equipment	Part Number
SCXI-1300 front terminal block	776573-00
SCXI-1310 96-pin connector and shell	776573-10
SCXI-1340 cable assembly	776574-40
SCXI-1341 Lab-NB/Lab-PC/Lab-PC+ cable assembly	776574-41
SCXI-1342 PC-LPM-16 cable assembly	776574-42
SCXI-1343 screw terminal adapter	776574-43
SCXI-1344 Lab-LC cable assembly	776574-44
SCXI-1345 shielded cable	1 m 776574-451
	2 m 776574-452
	5 m 776574-455
	10 m 776574-450
SCXI-1346 shielded multichassis cable adapter	776574-46
SCXI-1347 SCXI shielded cable assembly	
with 1 m cable	776574-471
with 2 m cable	776574-472
with 5 m cable	776574-475
with 10 m cable	776574-470
SCXI-1349 SCXI shielded cable assembly	
with 1 m cable	776574-491
with 2 m cable	776574-492
with 5 m cable	776574-495
with 10 m cable	776574-490
SCXI-1350 multichassis adapter	776575-50
SCXI-1351 one-slot cable extender	776575-51
SCXI process-current resistor kit	776582-01
Standard ribbon cable	0.5 m 180524-05
	1.0 m 180524-10
NB5 cable	0.5 m 181304-05
	1.0 m 181304-10
NB6 cable	
0.5 m	181305-01
1.0 m	181305-10

Refer to the *Signal Connections* section in Chapter 2, *Configuration and Installation*, and to Appendix E, *SCXI-1100 Cabling*, for additional information on cabling, connectors, and adapters.

Custom Cables

The SCXI-1100 rear signal connector is a 50-pin male ribbon-cable header. The manufacturer part number of the header National Instruments uses is as follows:

- AMP Inc. (part number 1-103310-0)

The mating connector for the SCXI-1100 rear signal connector is a 50-position polarized ribbon-socket connector with strain relief. National Instruments uses a polarized or keyed connector to prevent inadvertent upside-down connection to the SCXI-1100. Recommended manufacturer part numbers for this mating connector are as follows:

- Electronic Products Division/3M (part number 3425-7650)
- T&B/Ansley Corporation (part number 609-5041CE)

Part numbers of standard 50-conductor 28 AWG stranded-ribbon cables that you can use with these connectors are as follows:

- Electronic Products Division/3M (part number 3365/50)
- T&B/Ansley Corporation (part number 171-50)

The SCXI-1100 front connector is a 96-pin DIN C male connector. The manufacturer part number of this connector National Instruments uses is as follows:

- Harting Electronik Inc. (part number 09-03-396-6921)

The mating connector for the SCXI-1100 front connector is a 96-pin DIN C female connector. National Instruments uses a polarized connector to prevent inadvertent upside-down connection to the SCXI-1100. Recommended manufacturer part numbers for this mating connector are as follows:

- AMP Inc. (part number 535020-1; right-angle pins)
- Panduit Corporation (part number 100-096-434; straight-solder eyelet pins)

Unpacking

Your SCXI-1100 module is shipped in an antistatic package to prevent electrostatic damage to the module. Several components on the module can be damaged by electrostatic discharge. To avoid such damage in handling the module, take the following precautions:

- Touch the antistatic package to a metal part of your SCXI chassis before removing the module from the package.
- Remove the module from the package and inspect the module for loose components or any other sign of damage. Notify National Instruments if the module appears damaged in any way. *Do not* install a damaged module into your SCXI chassis.

Chapter 2

Configuration and Installation

This chapter describes the SCXI-1100 jumper configurations, installation of the SCXI-1100 into the SCXI chassis, signal connections to the SCXI-1100, and cable wiring.

Module Configuration

Revision C and later SCXI-1100 modules contain 10 jumpers that are shown in the parts locator diagram in Figure 2-1. For the Revision A and B parts locator diagram, see Appendix F, *Revision A and B Photo and Parts Locator Diagram*.

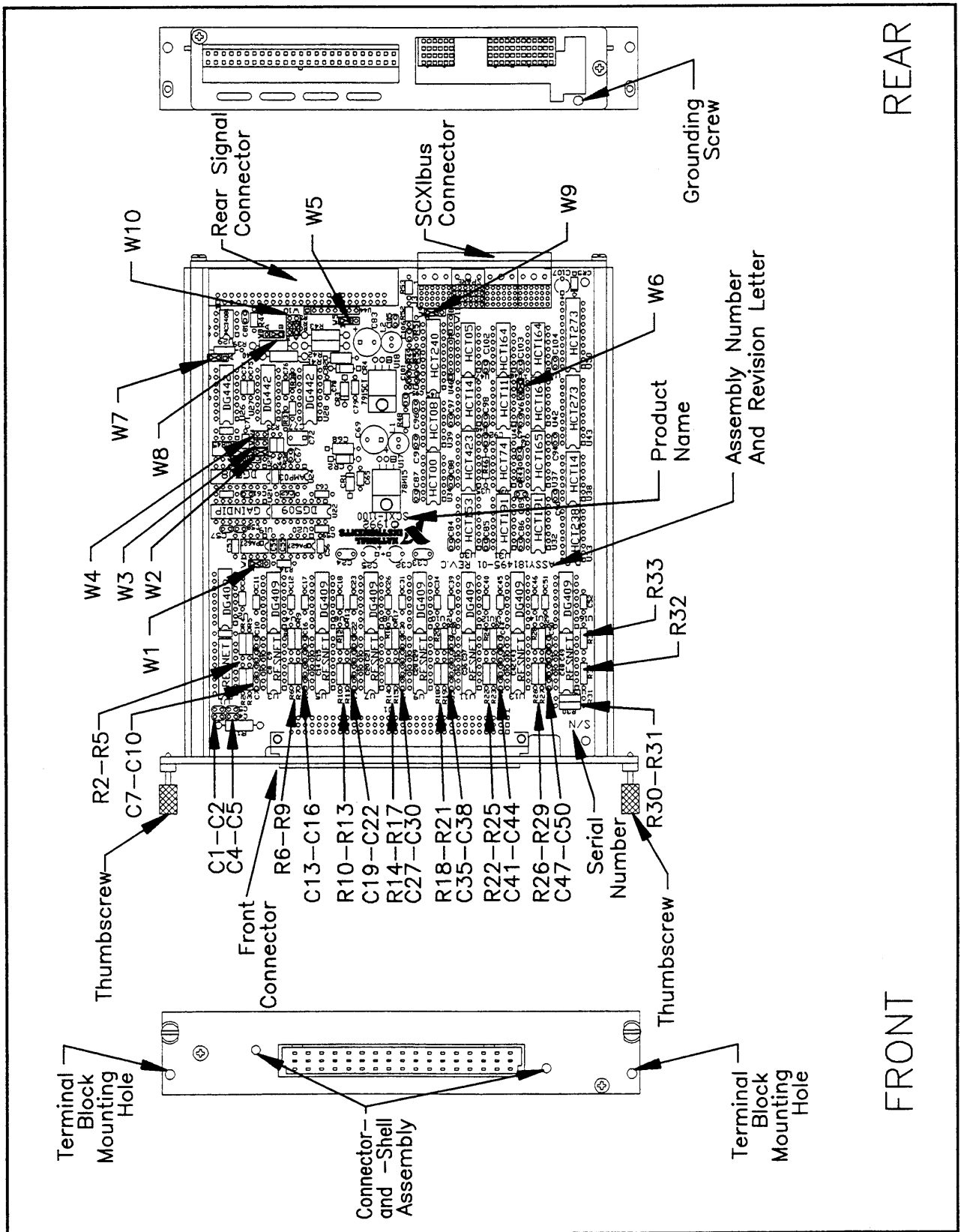

Figure 2-1. SCXI-1100 Parts Locator Diagram

The jumpers are used as follows:

- Fixed jumpers
 - Jumper W6 is reserved; do not remove this jumper.
 - On Revision A and B modules, jumper W9 is unused; do not connect this jumper.
 - On Revision C and later modules, jumper W11 does not exist. On Revision A and B modules, jumper W11 carries the SLOTOSEL* signal from the rear signal connector, after buffering, to the SCXIBus INTR* line; leave this jumper in the factory-default position (position A).
- User-configurable jumpers
 - Jumper W5 carries the SCXIBus MISO line, after buffering, to the SERDATOUT signal on the rear signal connector.
 - On Revision C and later modules, jumper W9 connects a pullup resistor to the SERDATOUT signal on the rear signal connector.
 - Jumper W10 configures the guard, the analog output ground, and enables the Pseudodifferential Output mode.
 - Jumpers W7 and W8 connect the module output to the front connector.
 - Jumper W1 provides a DC path for the bias current of the PGIA when used with floating or AC-coupled sources.
 - Jumpers W2 through W4 are used to set the lowpass filter (LPF) or full bandwidth (FBW).

Further configuration of the board is software controlled and is discussed later in this chapter.

Digital Signal Connections

The SCXI-1100 has two jumpers (three jumpers on Revision A and B modules) dedicated for communication between the data acquisition board and the SCXIBus backplane/Slot 0. These jumpers are W5 and W9 (and W11 on Revision A and B modules). In most cases, you do not need to move these jumpers. See Table 2-1 later in this chapter for the description and configuration of the jumper settings.

Jumper W5

Position 1 connects, after buffering, the SCXIBus MISO line to the SERDATOUT pin of the rear signal connector. This is the factory-default setting. In this setting, along with the proper setting of jumper W9, the data acquisition board can read the Module ID Register of the SCXI-1100. See the *Timing Requirements and Communication Protocol* section later in this chapter, and Chapter 4, *Register Descriptions*, for information on reading the Module ID Register. See Appendix E, *SCXI-1100 Cabling*, for the pin equivalences of the SCXI-1100 rear signal connector and the data acquisition board I/O connector. This position is marked on the module.

Position 3 disconnects SERDATOUT from the SCXIBus MISO line.

Jumper W9

On Revision C and later modules, position 1 connects a 2.2 k Ω pullup resistor to the SERDATOUT line. Position 3 does not connect the pullup resistor to the SERDATOUT line. On Revision A and B modules, do not connect jumper W9.

Using Jumpers W5 and W9

If the SCXI-1100 is not cabled to a data acquisition board, the positions of these jumpers do not matter, so leave them in their factory-default positions (both in position 1).

If the SCXI-1100 is cabled to a data acquisition board, and the SCXI chassis that the SCXI-1100 is in, is the only SCXI chassis cabled to that data acquisition board, leave the jumpers in their factory-default positions (both in position 1).

If the SCXI-1100 is cabled to a data acquisition board, and there are multiple SCXI chassis cabled to that data acquisition board with shielded cables (you are using SCXI-1346 shielded cable multichassis adapters), leave the jumpers in their factory-default positions (both in position 1).

If the SCXI-1100 is cabled to a data acquisition board, and there are multiple SCXI chassis cabled to that data acquisition board with ribbon cables (you are using SCXI-1350 multichassis adapters), leave jumper W5 in its factory-default position (position 1). On all but one of the SCXI-1100s that are cabled to the data acquisition board, move jumper W9 to position 3. It does not matter which of the SCXI-1100 modules that are cabled to the data acquisition board has jumper W9 set to position 1. If you have different types of modules cabled to the data acquisition board, those different modules will have jumpers similar to W5 and W9 of the SCXI 1100. Set those jumpers on the different modules using the same method described here for the SCXI-1100.

On Revision A and B SCXI-1100s, jumper W9 is not used. You set jumper W5 as explained in the cases above, except in the case of a multiple chassis ribbon-cable system. In a multichassis ribbon-cable system with Revision A and B SCXI-1100s cabled to the data acquisition board, you can access the MISO line in only one chassis. Pick one of the chassis that has the SCXI-1100 cabled to the data acquisition board. Set jumper W5 on the SCXI-1100 to position 1. On the SCXI-1100s that are in the other chassis and cabled to the data acquisition board, set jumper W5 to position 3. Notice that you will only be able to access digital information from the chassis that has the SCXI-1100 with jumper W5 set to position 1.

Jumper W11 (Revision A and B Modules Only)

On Revision C and later modules, jumper W11 does not exist. SLOT0SEL* is always buffered to the INTR* line.

On Revision A and B modules, position A connects, after buffering, SLOT0SEL* to the SCXIBus INTR* line. Do not change the factory setting, position A. In this setting, the data

acquisition board controls the SCXIbus INTR* line. See the *Timing Requirements and Communication Protocol* section later in this chapter, and Chapter 5, *Programming*, for information on the use of the INTR* line. See Appendix E, *SCXI-1100 Cabling*, for the pin equivalences of the SCXI-1100 rear signal connector and the data acquisition board I/O connector.

Do not use position B, which is reserved.

Table 2-1. Digital Signal Connections, Jumper Settings

Jumper	Description	Configuration
W5	Connects MISO to SERDATOUT; factory-default setting	
W5	Parking position	
W6	Factory setting; do not remove this jumper	
W9	Connects pullup to SERDATOUT (Revision C and higher modules only); factory-default setting	
W9	Parking position (not connected on Revision A and B modules)	
W11	Factory default (Revision A and B modules only)	

Analog Configuration

The SCXI-1100 has seven analog configuration jumpers—W10, W7, W8, W1, W2, W3, and W4. Use these jumpers to configure the output mode, reference mode, filter selection, and amplifier output selection.

Grounding, Shielding, and Output Mode Selection

Jumper W10

Position A-R0R1 is the parking position and the factory setting.

Position AB-R0 connects the PGIA reference to the analog output ground (pins 1 and 2 on the rear signal connector).

Position AB-R1 connects the PGIA reference to the SCXIbus guard.

Position AB-R2 enables the Pseudodifferential Output mode and connects the PGIA reference to the OUTREF pin on the rear signal connector. Select this mode when the SCXI-1100 has to operate with data acquisition boards that have a nonreferenced single-ended input (NRSE). Do not use differential input data acquisition boards when jumper W10 is in the AB-R2 position.

Table 2-2. Jumper W10 Settings

Jumper	Description	Configuration
W10	Factory setting; parking position (used with MIO boards in differential mode)	
W10	Connects the data acquisition analog ground (pins 1 and 2 on the rear signal connector) to the PGIA reference (used with single-ended boards)	
W10	Connects the PGIA reference to the SCXIbus guard	
W10	Enables the Pseudodifferential Output mode (connects pin 19 of the PGIA output reference to the rear signal connector)	

When using the SCXI-1100 with data acquisition boards such as the MIO boards, use the Differential Input mode configuration to eliminate ground problems. With single-ended data

acquisition boards, such as the Lab boards and the PC-LPM-16, place jumper W10 in position AB-R0 to connect the data acquisition board ground reference to the module analog ground reference.

Reference Mode Selection

Jumper W1

Jumper W1 references the negative (-) input of the PGIA to ground through a 100 k Ω resistor.

The SCXI-1100 is shipped with jumper W1 in the parking position. Use this setting when connecting to signals that are referenced to ground.

If you are measuring floating sources, you can move jumper W1 to position 3 to reference the negative (-) input of the PGIA to ground through the 100 k Ω resistor. Refer to Figures 2-3, 2-4, and 2-5 later in this chapter for signal connection diagrams.

Note: If all of the sources are floating, you can configure jumper W1 to connect a 100 k Ω resistor to the negative input of the amplifier to prevent saturation of the amplifier inputs. This reduces the input impedance, however, and usually increases settling time and common-mode noise. Also, if any of the sources are ground-referenced or have high leakage to ground, a ground loop can result, causing DC offsets or noise. Therefore, it is best if you do not use this jumper but instead connect your floating channels to the chassis ground on the terminal block via a wire.

Table 2-3. Jumper W1 Settings

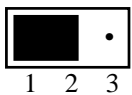
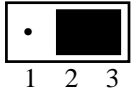
Jumper	Description	Configuration
W1	Factory setting; parking position (used for ground-referenced sources)	
W1	Floating source connection	

For more information on input signal connections, see the *Signal Connections* section later in this chapter.

Filter Selection

Jumpers W2 through W4

One jumper block is provided for jumpers W2, W3, and W4:

- When you connect jumper W2, the SCXI-1100 does not filter.
- When you connect jumper W3, a 10 kHz lowpass filter filters the conditioned signal.
- When you connect jumper W4, a 4 Hz lowpass filter filters the conditioned signal.

Table 2-4. Jumpers W2, W3, and W4 Settings

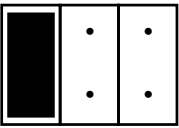
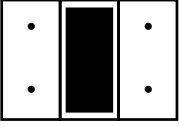
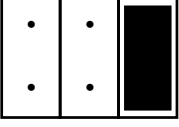
Jumper	Description	Configuration
W2	Factory setting is full bandwidth (FBW) and no filtering	 W2 W3 W4
W3	10 kHz lowpass filter	 W2 W3 W4
W4	4 Hz lowpass filter	 W2 W3 W4

Note: The settling time varies greatly when you configure the SCXI-1100 to a 4 Hz or 10 kHz filter or full bandwidth. Refer to Appendix A, *Specifications*, for details on how fast you can scan in each case.

Output Selection

Jumpers W7 and W8

Position A connects the module output channel MCH0 to the front connector. Position B disconnects the front connector from the module output. Use this setting if you do not need the amplifier output at the front connector. Refer to the *Analog Output* section later in this chapter for more information.

Table 2-5. Jumpers W7 and W8 Settings

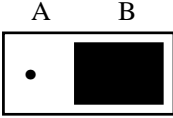
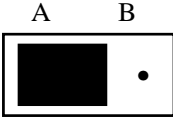
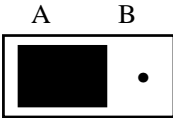
Jumper	Description	Configuration
W7	Factory setting; parking position. Disconnects the front connector from the module output	
W8	Factory setting; parking position	
W7	Amplifier Output is connected to the front connector OUTPUT pin	
W8	Amplifier Reference is connected to the front connector AOREF pin	

Input Filtering and Current Loop Receivers

If you need input filtering, pads in which you can insert a capacitor are available at each input channel. Table 2-6 shows which capacitor reference designator corresponds to which input channel.

Table 2-6. User-Defined Input Filter Capacitors

Input Channel	Spare Capacitor Reference Designator
0	C1
1	C5
2	C4
3	C2
4 through 7	C10 through C7 respectively
8 through 11	C16 through C13 respectively
12 through 15	C22 through C19 respectively
16 through 19	C30 through C27 respectively
20 through 23	C38 through C35 respectively
24 through 27	C44 through C41 respectively
28 through 31	C50 through C47 respectively

In addition, pads are available for transforming individual channels to current-to-voltage converters. National Instruments manufactures an SCXI process-current pack, which consists of a package of four 249 Ω , 0.1%, 5 ppm/ $^{\circ}\text{C}$, 1/4 W resistors. The part number for this kit is in the *Optional Equipment* section of Chapter 1, *Introduction*. Table 2-7 shows the input channels and their corresponding resistor reference designators.

Table 2-7. User-Defined Current Receiver Resistors

Input Channel	Resistor Reference Designator
0 through 3	R5 through R2 respectively
4 through 7	R9 through R6 respectively
8 through 11	R13 through R10 respectively
12 through 15	R17 through R14 respectively
16 through 19	R21 through R18 respectively
20 through 23	R25 through R22 respectively
24 through 27	R29 through R26 respectively
28 through 31	R33 through R30 respectively

For more information, refer to the *Analog Input and Timing Circuits* section in Chapter 3, *Theory of Operation*.

To install either the capacitors or the resistors, perform the following steps before installing your module in the SCXI chassis:

1. Take off the module cover by removing the grounding screw at the rear of the module.
2. Take off the rear panel by removing the two other screws.
3. Slide the module out of its enclosure.
4. Insert the capacitor(s) and/or resistor(s) into their appropriate pads.
5. Solder the leads to the pads on the solder side of the board.
6. Trim the leads to 0.06 in. maximum.
7. Slide the module back into its enclosure.
8. Reinstall the rear panel.
9. Reinstall the top cover and grounding screw.

Your module is ready to be installed into the chassis.

Hardware Installation

You can install the SCXI-1100 in any available SCXI chassis. After you have made any necessary changes and have verified and recorded the jumper settings (a form is included in Appendix G, *Customer Communication*), you are ready to install the SCXI-1100. The following are general installation instructions. Consult your SCXI chassis user manual for specific instructions and warnings.

1. Turn off the computer that contains the data acquisition board or disconnect the data acquisition board from your SCXI chassis.
2. Turn off the SCXI chassis. Do not insert the SCXI-1100 into a chassis that is turned on.

3. Insert the SCXI-1100 into the board guides. Gently guide the module into the back of the slot until the connectors make good contact. If you have already installed a cable assembly in the rear of the chassis, you must firmly engage the module and cable assembly; however, do not *force* the module into place.
4. Screw the front mounting panel of the SCXI-1100 to the top and bottom threaded strips of your SCXI chassis.
5. If you will connect this module to any MIO data acquisition board except the AT-MIO-16D and the AT-MIO-64F-5, attach the connector at the metal end of an SCXI-1340 cable assembly to the rear signal connector on the SCXI-1100 module. Screw the rear panel to the rear threaded strip. Attach the loose end of the cable to the MIO board.

Note: If you already have another module in your chassis that is cabled to your data acquisition board, you generally do not need to connect additional cabling to the SCXI-1100. Typically, only one module in a chassis is cabled to a data acquisition board.

For installation procedures with other SCXI accessories and data acquisition boards, consult Appendix E, *SCXI-1100 Cabling*.

6. Check the installation.
7. Turn on the SCXI chassis.
8. Turn on the computer or reconnect the data acquisition board to your chassis.

The SCXI-1100 module is installed and ready for operation.

Signal Connections

This section describes the input and output signal connections to the SCXI-1100 board via the SCXI-1100 front connector and rear signal connector, and includes specifications and connection instructions for the signals given on the SCXI-1100 connectors.

Warning: Connections to any terminal that exceed any of the maximum ratings of input or output signals on the SCXI-1100 can damage the SCXI-1100 module and the SCXIbus backplane. Maximum input ratings for each signal are given in this chapter under the discussion of that signal. National Instruments is *not* liable for any damages resulting from signal connections that exceed these ratings.

Front Connector

Figure 2-2 shows the pin assignments for the SCXI-1100 front connector.

Pin Number	Signal Name	Column			Signal Name
		A	B	C	
32	CGND	○	○	○	CH0-
			○	○	CH0+
31			○	○	CH1-
				○	CH1+
30			○	○	CH2-
				○	CH2+
29			○	○	CH3-
				○	CH3+
28			○	○	CH4-
				○	CH4+
27		○	○	CH5-	
			○	CH5+	
26		○	○	CH6-	
			○	CH6+	
25		○	○	CH7-	
			○	CH7+	
24	CGND	○	○	○	CH8-
				○	CH8+
23			○	○	CH9-
				○	CH9+
22			○	○	CH10-
				○	CH10+
21			○	○	CH11-
				○	CH11+
20			○	○	CH12-
				○	CH12+
19		○	○	CH13-	
			○	CH13+	
18		○	○	CH14-	
			○	CH14+	
17		○	○	CH15-	
			○	CH15+	
16	CGND	○	○	○	CH16-
				○	CH16+
15			○	○	CH17-
				○	CH17+
14			○	○	CH18-
				○	CH18+
13			○	○	CH19-
				○	CH19+
12			○	○	CH20-
				○	CH20+
11		○	○	CH21-	
			○	CH21+	
10		○	○	CH22-	
			○	CH22+	
9		○	○	CH23-	
			○	CH23+	
8	OUTPUT	○	○	○	CH24-
				○	CH24+
7	AOREF	○	○	○	CH25-
				○	CH25+
6	GUARD	○	○	○	CH26-
				○	CH26+
5	CGND	○	○	○	CH27-
				○	CH27+
4	DTEMP	○	○	○	CH28-
				○	CH28+
3	MTEMP	○	○	○	CH29-
				○	CH29+
2	CGND	○	○	○	CH30-
				○	CH30+
1	+5 V	○	○	○	CH31-
				○	CH31+

Figure 2-2. SCXI-1100 Front Connector Pin Assignment

Front Connector Signal Descriptions

Pin	Signal Name	Description
A1	+5 V	+5 VDC Source – Used to power the temperature sensor on the terminal block. 0.2 mA of source not protected.
A2, A5, A16, A24, A32	CGND	Chassis Ground – Tied to the SCXI chassis.
A3	MTEMP	Multiplexed Temperature Sensor – Connects the temperature sensor to the output multiplexer.
A4	DTEMP	Direct Temperature Sensor – Connects the temperature sensor to the MCH1+ signal when the terminal block is configured for direct temperature connection.
A6	GUARD	Guard – Connected to the SCXIbus guard.
A7	AOREF	Analog Output Reference – Connected to the MCH0- signal as described in the <i>Analog Configuration</i> section.
A8	OUTPUT	Output – Connected to the MCH0+ signal as described in the <i>Analog Configuration</i> section.
B1-B32	CH31- through CH0-	Negative Input Channels – Negative input channels to the PGIA.
C1-C32	CH31+ through CH0+	Positive Input Channels – Positive input channels to the PGIA.

The signals on the front connector are all analog but can be divided into three groups—the analog input channels, the temperature sensor, and the analog output channel.

Analog Input Channels

Columns B and C constitute the analog input channels for the multiplexed PGIA inputs. The inputs are configured in Differential mode, hence you should ground reference the measured signal if it is floating. If the measured signals are floating, connect jumper W1 (position 2-3) to produce a DC path for the input bias currents; otherwise, the PGIA bias currents charge up stray capacitances, resulting in uncontrollable drift and possible saturation. Figure 2-3 illustrates how to connect a ground-referenced signal. Figure 2-4 illustrates how to connect a floating signal. Figure 2-5 shows how to connect AC-coupled signals.

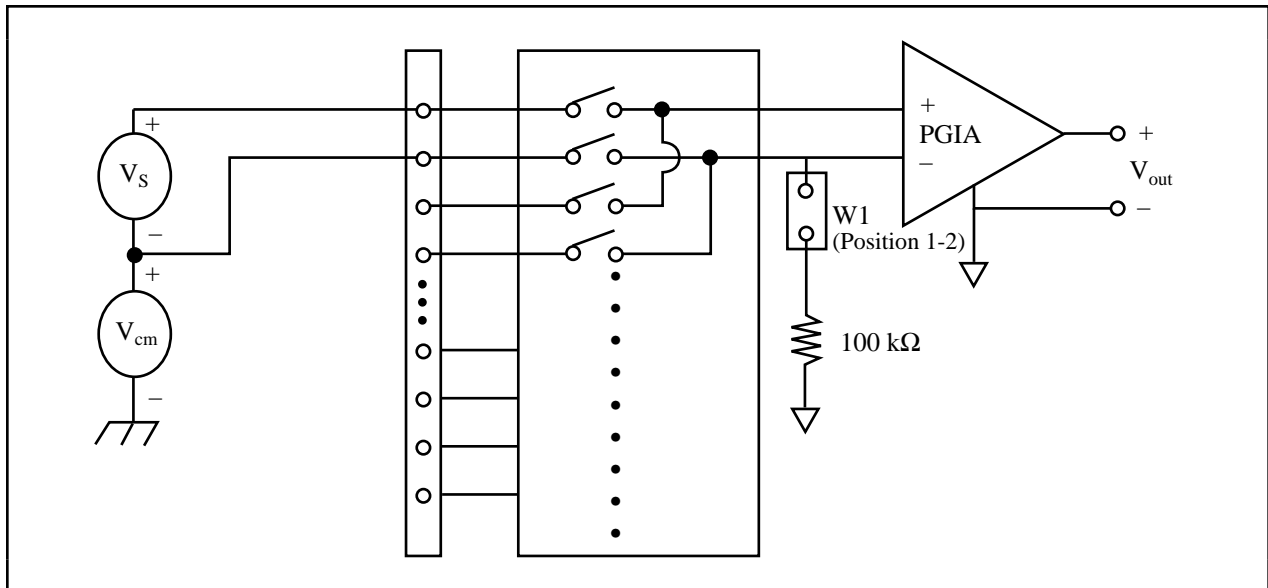

Figure 2-3. Ground-Referenced Signal Connection

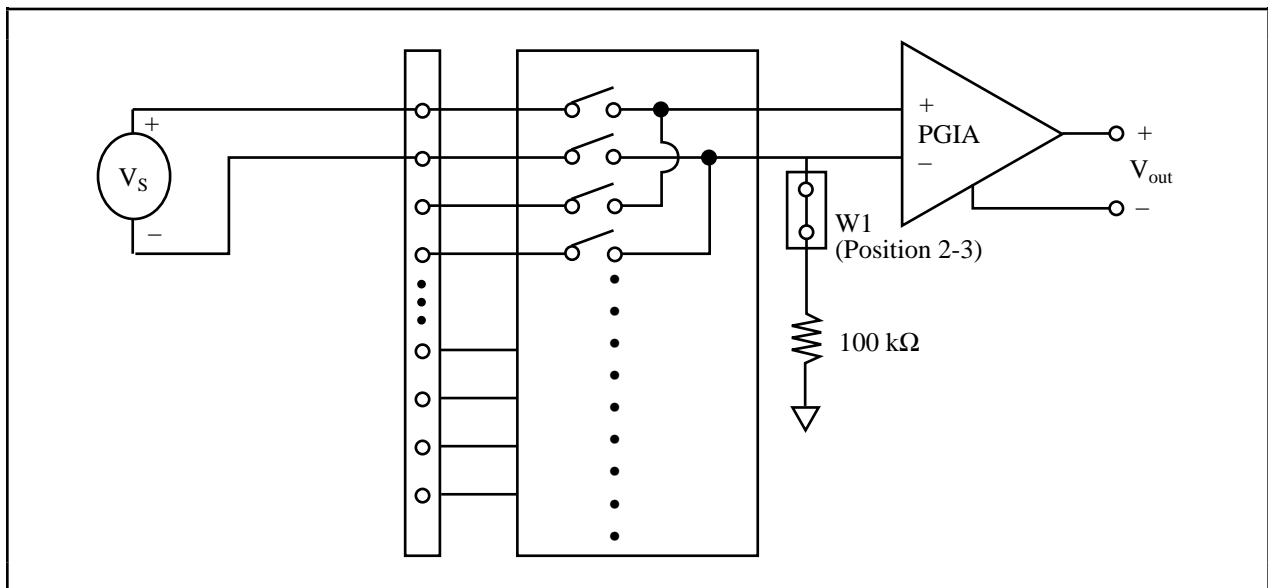

Figure 2-4. Floating Signal Connection

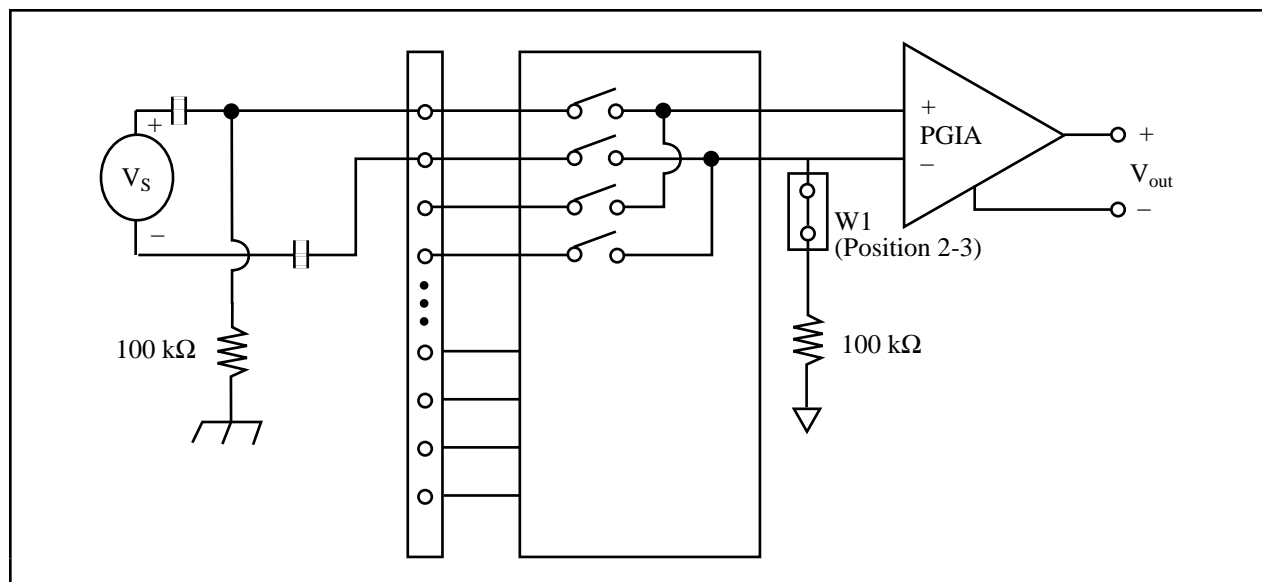

Figure 2-5. AC-Coupled Signal Connection

For AC-coupled signals, connect jumper W1 and an external resistor from the positive input channel to the chassis ground. This connection produces the DC path for the positive input bias current. Typical resistor values range from 100 kΩ to 1 MΩ. Although this configuration is necessary in this case, it lowers the input impedance of the PGIA and introduces an additional offset voltage proportional to the input offset current and to the resistor value used. The typical input offset current of the PGIA consists of ±350 pA and a negligible offset drift current. A 100 kΩ resistor results in ±35 μV of offset, which is insignificant in most applications. However, if you use larger valued bias resistors, significant input offset may result. To determine the maximum offset introduced by the biasing resistor, use the following equation:

$$V_{\text{ofsbias}} = I_{\text{ofsbias}} (R_{\text{bias}}) + (|R_{\text{bias}} - 100 \text{ k}\Omega|) I_{\text{bias}}$$

Use a 100 kΩ value when you use jumper W1 to reduce the amount of offset as well as to maintain a balanced input and avoid the degradation of the PGIA common-mode rejection ratio (CMRR). If you need larger valued biasing resistors, do not use jumper W1, and tie an external biasing resistor to the negative input channels.

For DC-coupled signals, connect jumper W1; no external resistors are required. This configuration internally connects a 100 kΩ value from the negative input of the PGIA to ground, producing the required biasing. This configuration does not affect the input offset or the differential input impedance because the voltage developing across the bias resistor appears as a common-mode voltage.

The SCXI-1100 PGIA can reject any voltage within its common-mode input range that ground potential differences between the signal source and the module introduce. In addition, the PGIA can reject common-mode noise pickup in the leads connecting the signal sources to the SCXI-1100.

The common-mode input range of the SCXI-1100 PGIA is the magnitude of the greatest common-mode signal that the SCXI-1100 can reject. The PGIA can reject common-mode

signals in which both the positive and negative channel inputs are in the ± 10 V range. Thus the common-mode input range for the SCXI-1100 depends on the size of the differential input signal:

$$V_{\text{diff}} = V_{\text{in}^+} - V_{\text{in}^-}$$

The exact formula for the permissible common-mode input range is as follows:

$$V_c = \pm (10 \text{ V} - G_1(V_{\text{in}^+} - V_{\text{in}^-})/2)$$

Thus, with a differential voltage of 10 V and a first-stage gain of $G_1 = 1$, the maximum possible common-mode voltage would be ± 5 V. You measure the actual common-mode voltage available at the PGIA input with respect to the SCXI-1100 ground. You can calculate the actual common-mode voltage with the following formula:

$$V_{\text{cm-actual}} = (V_{\text{in}^+} + V_{\text{in}^-})/2$$

where V_{in^+} is the signal at the positive input channel (CH#+) and V_{in^-} is the signal at the negative input channel (CH#-). Both V_{in^+} and V_{in^-} are measured with respect to the SCXI-1100 chassis ground.

The analog input channels are overvoltage protected to ± 25 VDC with power on and to ± 15 VDC with power off at a maximum of 20 mA sink or source.

Warning: Exceeding the differential and common-mode input ranges results in distorted input signals. Exceeding the maximum input voltage rating between any two terminals can damage the SCXI-1100, the SCXIbus backplane, and the data acquisition board. National Instruments is *not* liable for any damages resulting from such signal connections.

Thermocouple Connections

One of the main applications of the SCXI-1100 is thermocouple measurements. This section describes the different type of thermocouple connections.

Your thermocouple can be either floating or ground referenced. When you connect your thermocouple, make sure you know whether the thermocouple is floating or ground referenced.

If you are using a floating thermocouple, you must ground the PGIA CH- in one of the following two ways:

- Connect a wire on the terminal block from the CH- of interest to the chassis ground screw terminal. If you are using several similar thermocouples, you can daisy chain the CH- of interest to the chassis ground screw terminal. Use this method to avoid grounding all the SCXI-1100 CH- and to create a solid ground connection; this is the recommended method of referencing floating thermocouples.
- Internally connect jumper W1 to the floating source position. This will connect all SCXI-1100 CH- inputs to ground via a 100 k Ω resistor. However, this setting usually increases settling time and common-mode noise.

If you are using a grounded thermocouple, do not ground the SCXI-1100 CH- and do *not* use jumper W1 to ground floating signals because you will create a ground loop and adversely affect the accuracy of your measurement.

Open Thermocouple Detection

For the SCXI-1100 to be able to detect open thermocouples, you must properly connect your signals as explained in the previous section.

When the thermocouple opens, the PGIA bias currents charge the internal parasitic capacitors, driving the PGIA inputs and output to saturation. Because it is not possible to predict the direction of the bias currents, the PGIA can saturate to either the positive or negative rail. This is open thermocouple detection.

Because the PGIA has low bias currents, the charging of the stray capacitances, and therefore saturation, can be a slow process. It is best to have a self-test scan to check for open thermocouples. Perform this self-test scan with the SCXI-1100 gain set to a minimum of 100 and the scan at a maximum rate of 15 Hz when you are in full bandwidth or in the 10 kHz filter, and 3.5 Hz when you are in the 4 Hz filter. You can then execute this scan at regular intervals to verify that all the thermocouples are connected. Saturation or a positive or negative reading outside the expected range indicates an open thermocouple.

Analog Output

You can connect MCH0+ and MCH0- to the front connector to pins A8 and A7, respectively, via internal jumpers as described in the *Output Selection* section earlier in this chapter. When you do not need the module output at the front connector, place jumpers W7 and W8 in position B, thus connecting pins A8 and A7 of the front connector to the module analog ground. This connection reduces the amount of noise and stray capacitance coupling from the amplifier output to its inputs, improving the settling time performance. In addition to the analog output, pin A6 connects to the SCXIbus guard.

Connector-and-Shell Assembly

Two types of signal connectors are available to connect the signals to the SCXI-1100. The first, the SCXI-1310 96-pin connector-and-shell assembly, is available in a kit listed in the *Optional Equipment* section in Chapter 1, *Introduction*. The connector has eyelet ends for easy hook-and-solder wire connection. With this kit, you can build your own signal cable to connect to the SCXI-1100 inputs. After you have built the cable, use the shell to cover and protect the connector.

Perform the following steps to build and mount the connector-and-shell assembly to your SCXI module:

1. Refer to Figure 2-6 and the diagram included with your SCXI-1310 kit to build the connector-and-shell assembly.
2. Turn off the computer that contains your plug-in board or disconnect the board from your SCXI chassis.
3. Turn off your SCXI chassis.
4. Slide the module out of the chassis.
5. Remove the module cover. Refer to Figure 2-6 as you complete the remaining steps.
6. Place one jack screw as indicated in Figure 2-6.

7. While holding the jack screw in place, insert the lock washer and then the nut. Notice that you might need long-nose pliers to insert the washer and nut.
8. Tighten the nut by holding it firmly and rotating the jack screw.
9. Repeat steps 6 through 8 for the second jack screw.
10. Replace the module cover and tighten the grounding screw.
11. Slide the module back into place in the chassis.
12. Connect the connector-and-shell assembly to your module front connector and secure the assembly by tightening both mounting screws.

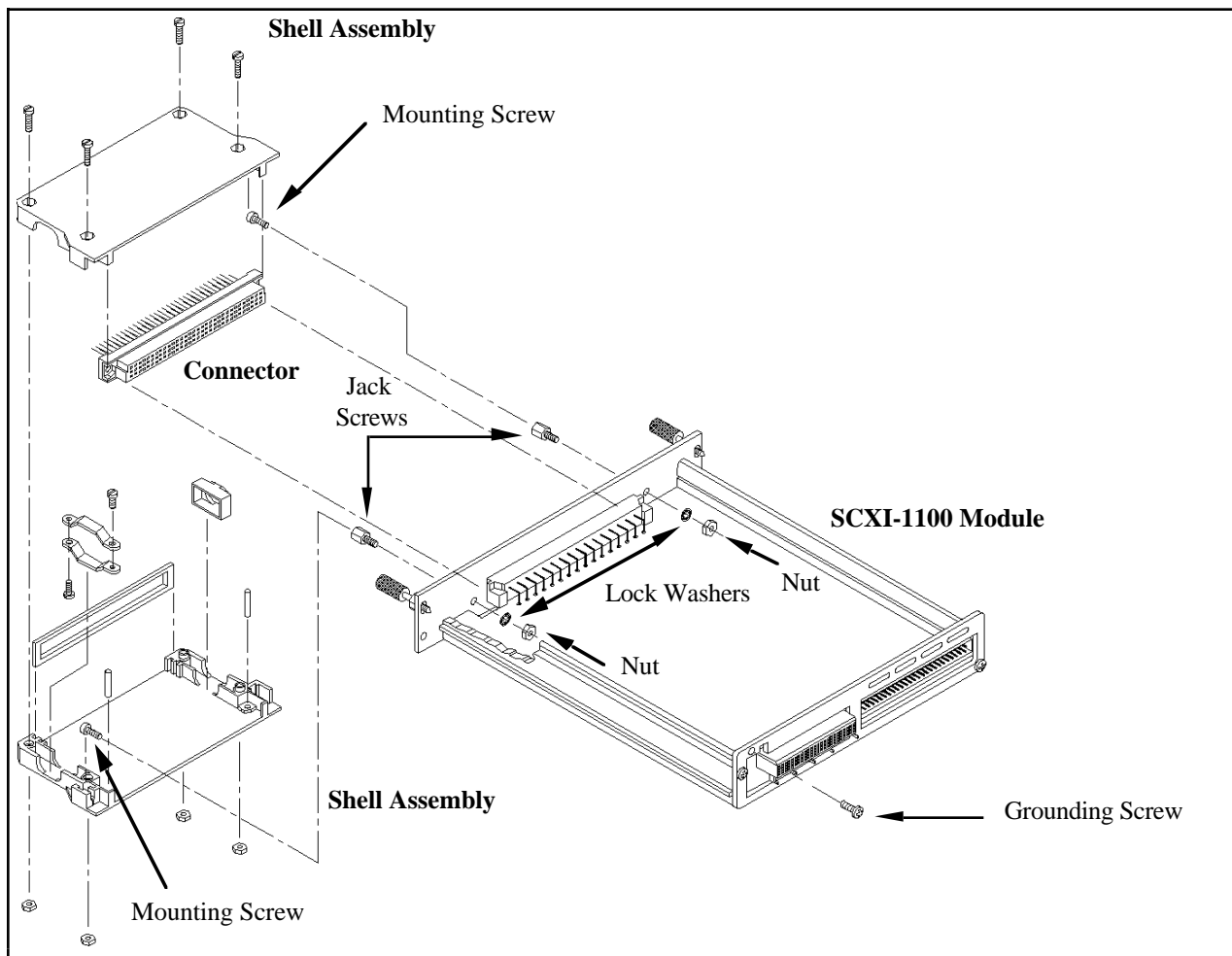

Figure 2-6. Assembling and Mounting the Connector-and-Shell Assembly

SCXI-1300 Terminal Block

The second type of connector available to connect the signals to the SCXI-1100 inputs is the SCXI-1300 terminal block, which consists of a shielded board with 72 screw terminals to connect to the SCXI-1100 input connector. Thirty-two pairs of screw terminals are for signal connection to the 32 differential inputs of the SCXI-1100. One pair of screw terminals connects to the chassis ground. Three screw terminals connect to the SCXI-1100 OUTPUT and AOREF pins and to the SCXIbus guard. The remaining three screw terminals are not used. In addition, solder pads are on each side of the terminal block for circuit additions.

Terminal Block Temperature Sensor

The temperature sensor is located on the SCXI-1300 terminal block. You can connect the temperature sensor in two ways:

- **Multiplexed Temperature Sensor (MTS) mode**—Connect the temperature sensor to the MTEMP pin (A3) on the front connector and multiplex the sensor at the output multiplexer along with the PGIA output.
- **Direct Temperature Sensor (DTS) mode**—Connect the temperature sensor to a separate data acquisition channel via MCH1± (pins 5 and 6 on the rear signal connector).

The temperature sensor outputs 10 mV/°C and has an accuracy of ±0.9° C over the 0° to 55° C temperature range. To determine the temperature, use the following formulas:

$$T(^{\circ}\text{C}) = 100(V_{\text{TEMPOUT}})$$

$$T(^{\circ}\text{F}) = \frac{[T(^{\circ}\text{C})] 9}{5} + 32$$

where V_{TEMPOUT} is the temperature sensor output and $T(^{\circ}\text{F})$ and $T(^{\circ}\text{C})$ are the temperature readings in degrees Fahrenheit and degrees Celsius, respectively.

Terminal Block Jumper Configuration





The SCXI-1100 has two jumpers for configuring the onboard temperature sensor. Jumper W1 (MTEMP) connects the temperature sensor output to the SCXI-1100 output multiplexer. This is the factory setting. Jumper W2 (DTEMP) connects the temperature sensor to the SCXI-1100 MCH1+ signal on the rear signal connector.

In both MTS and DTS modes, the reference to the temperature sensor signal is the SCXI-1100 analog ground that is connected to MCH0- in the MTS mode and to MCH1- in the DTS mode. Notice that MCH1- is continuously connected to the SCXI-1100 ground, whereas MCH0- is switched through the output multiplexer.

One jumper block comprises both jumpers; thus, you can use only one type of configuration at a time. The parking position for the jumper block is in the MTEMP position. The temperature sensor is disabled until the RTEMP bit in the Configuration Register selects the sensor.

Table 2-8 shows the SCXI-1300 jumper settings.

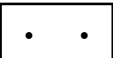
Table 2-8. Jumper Setting on the Terminal Block

Jumper	Position	Description
W1	 MTEMP	MTS mode selected; factory setting; parking position
W2	 DTEMP	
W1	 MTEMP	DTS mode selected
W2	 DTEMP	

Terminal Block Signal Connection

To connect the signal to the terminal block, you will need Phillips-head number 1 and number 2 screwdrivers and a 0.125 in. flathead screwdriver. Use the following procedure (refer to the SCXI-1300 terminal block parts locator diagram in Figure 2-7):

1. Remove the grounding screw of the top cover with the Phillips-head number 1 screwdriver.
2. Snap out the top cover of the shield by placing the flathead screwdriver in the groove at the bottom of the terminal block.
3. After loosening the strain-relief screws with the Phillips-head number 2 screwdriver, slide the signal wires one at a time through the front panel strain-relief opening. Add insulation or padding if necessary.
4. Connect the wires to the screw terminals by inserting the wires into the terminals and tightening the screw without letting the wires slip out of the strain-relief bar.
5. Tighten the larger strain-relief screws.
6. Snap the top cover back into place.
7. Reinsert the grounding screw to ensure proper shielding.
8. Connect the terminal block to the SCXI-1100 front connector as explained in the *Terminal Block Installation* section, the next section in this chapter.

Terminal Block Installation

To connect the terminal block to the SCXI-1100 front connector, perform the following steps:

1. Connect the SCXI-1100 front connector to its mating connector on the terminal block.
2. Make sure that the SCXI-1100 top and bottom thumbscrews do not obstruct the rear panel of the terminal block.
3. Tighten the top and bottom screws on the back of the terminal block to hold it securely in place.

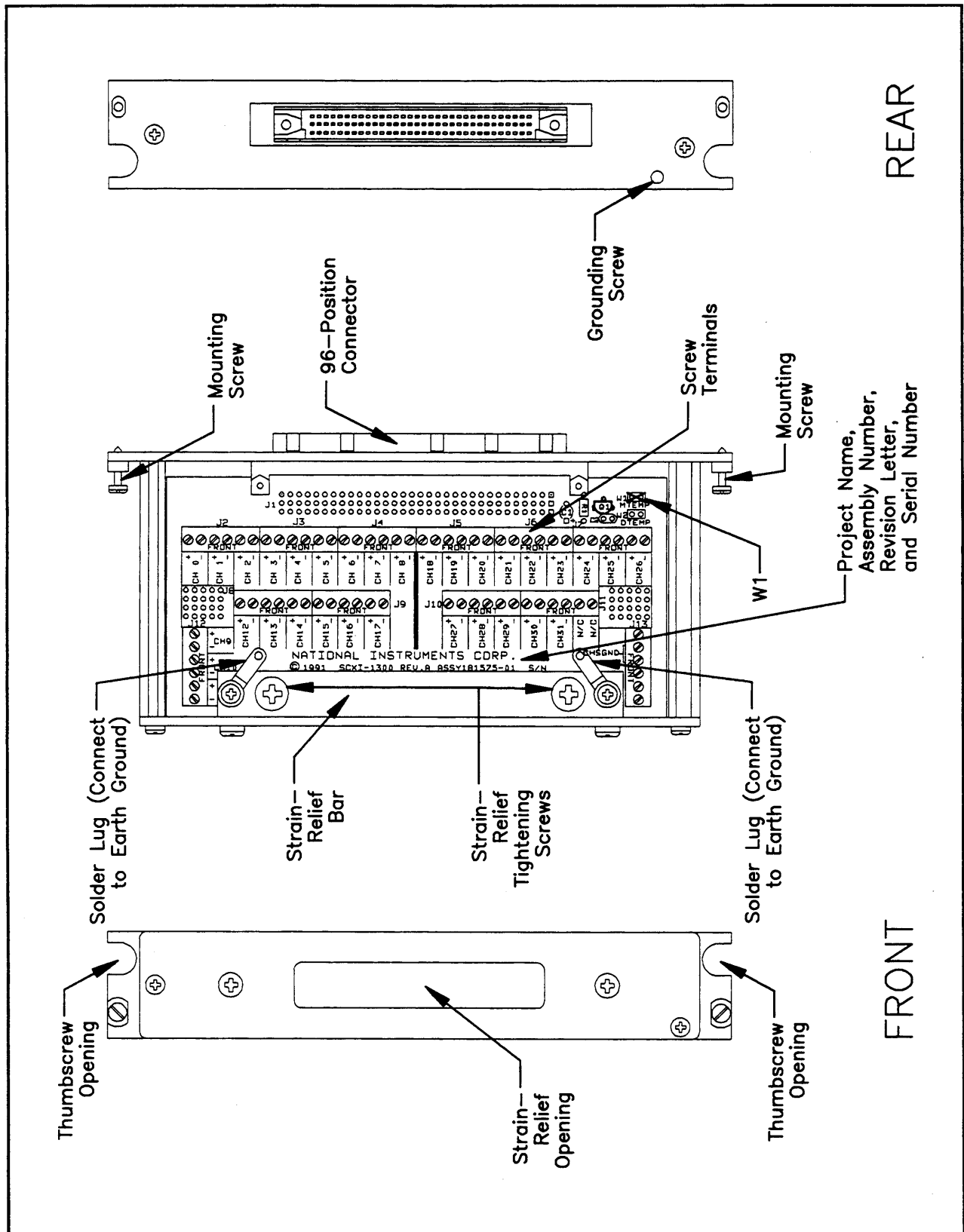

Figure 2-7. SCXI-1300 Parts Locator Diagram

Rear Signal Connector

Note: If you will be using the SCXI-1100 with a National Instruments data acquisition board and cable assembly, you do not need to read the remainder of this chapter. If you will also be using the SCXI-1180 feedthrough panel, the SCXI-1343 rear screw terminal adapter, or the SCXI-1351 one-slot cable extender with the SCXI-1100, you should read this section.

Figure 2-8 shows the pin assignments for the SCXI-1100 rear signal connector.

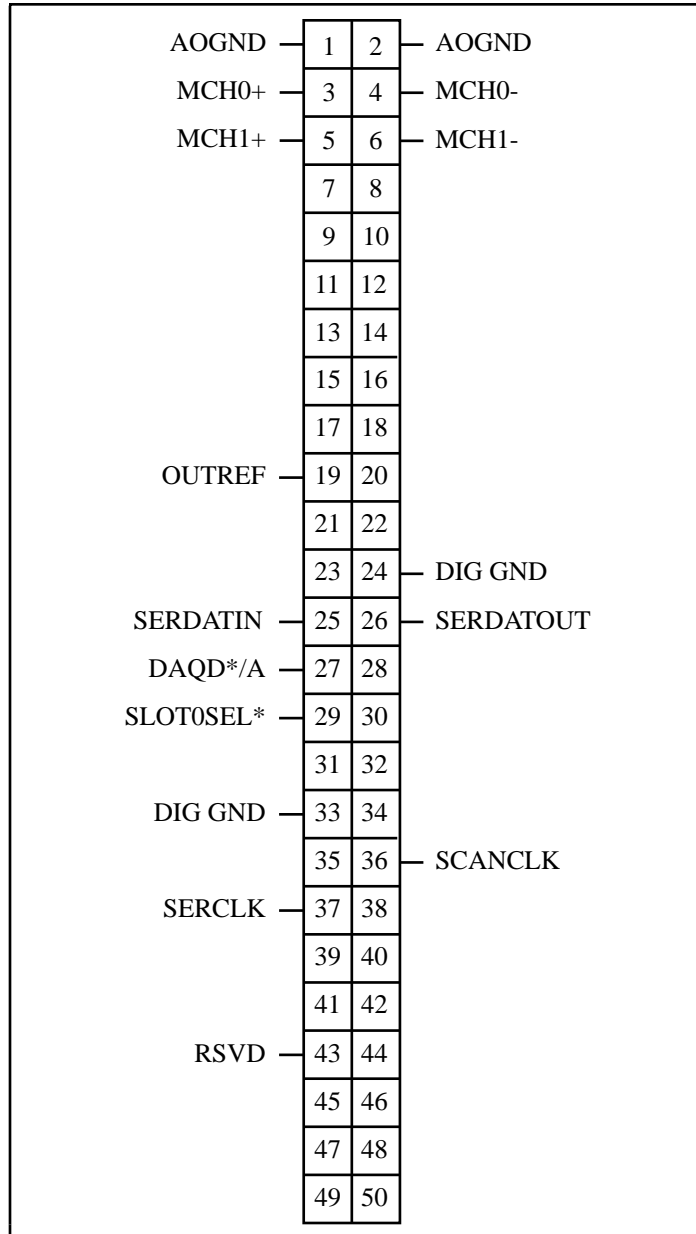

Figure 2-8. SCXI-1100 Rear Signal Connector Pin Assignment

Rear Signal Connector Signal Descriptions

Pin	Signal Name	Description
1-2	AOGND	Analog Output Ground – Connected to the PGIA reference when jumper W10 is in position AB-R0.
3-6	MCH0± and MCH1±	Analog Output Channels 0 and 1 – Connects to the data acquisition differential analog input channels.
19	OUTREF	Output Reference – Serves as the reference node for the PGIA output in the Pseudodifferential Output mode. You should connect OUTREF to the analog input sense of the NRSE data acquisition board.
24, 33	DIG GND	Digital Ground – Supply the reference for data acquisition digital signals and are tied to the module digital ground.
25	SERDATIN	Serial Data In – Taps into the SCXIBus MOSI line to provide serial input data to a module or Slot 0.
26	SERDATOUT	Serial Data Out – Taps into the SCXIBus MISO line to accept serial output data from a module.
27	DAQD*/A	Data Acquisition Board Data/Address Line – Taps into the SCXIBus D*/A line to indicate to the module whether the incoming serial stream is data or address information.
29	SLOT0SEL*	Slot 0 Select – Taps into the SCXIBus INTR* line to indicate whether the information on MOSI is being sent to a module or Slot 0.
36	SCANCLK	Scan Clock – Indicates to the SCXI-1100 that the data acquisition board has taken a sample; also causes the SCXI-1100 to change channels.
37	SERCLK	Serial Clock – Taps into the SCXIBus SPICLK line to clock the data on the MOSI and MISO lines.
43	RSVD	Reserved.

* Indicates active low.

All other pins are not connected.

See the *Timing Requirements and Communication Protocol* section later in this chapter for more detailed information on timing.

The signals on the rear signal connector are analog output signals, digital I/O signals, or timing I/O signals. Signal connection guidelines for each of these groups are given in the following section.

Analog Output Signal Connections

Pins 1 through 6 and pin 19 of the rear signal connector are analog output signal pins. Pins 1 and 2 are AOGND signal pins. AOGND is an analog output common signal that is routed through jumper W10 to the PGIA reference on the SCXI-1100. You can use these pins for a general analog power ground tie point to the SCXI-1100 if necessary. In particular, when using differential input data acquisition boards, such as the MIO boards, it is preferable to leave jumper W10 in its factory setting or in position AB-R1 to avoid ground loops. With data acquisition boards that are configured for referenced single-ended (RSE) measurements, set jumper W10 in position AB-R0 to connect the SCXI-1100 ground to the data acquisition analog ground. Pin 19, the OUTREF pin, is connected internally to the PGIA reference when jumper W10 is in position AB-R2. Pins 3 through 6 are the analog output channels of the SCXI-1100. Pins 3 and 4, or MCH0 \pm , are a multiplexed output of the PGIA output and the temperature sensor output. Pins 5 and 6, or MCH1 \pm , are a direct connection of the temperature sensor to the rear signal connector. Notice that the temperature sensor is located on the terminal block. For further details on configuring the temperature sensor output, refer to the *SCXI-1300 Terminal Block* section earlier in this chapter.

Warning: The SCXI-1100 analog outputs are *not* overvoltage protected. Applying external voltage to these outputs can damage the SCXI-1100. National Instruments is *not* liable for any damages resulting from such signal connections.

Digital I/O Signal Connections

Pins 24 through 27, 29, 33, 36, 37, and 43 constitute the digital I/O lines of the rear signal connector. These pins are divided into three categories—the digital input signals, the digital output signals, and the digital timing signals.

The digital input signals are pins 24, 25, 27, 29, 33, and 37. The data acquisition board uses these pins to configure the SCXI module when the module is under data acquisition board control. Each digital line emulates the SCXIbus communication signals as follows:

- Pin 25 is SERDATIN and is equivalent to the SCXIbus MOSI serial data input line.
- Pin 27 is DAQD*/A and is equivalent to the SCXIbus D*/A line. Pin 27 indicates to the module whether the incoming serial stream on SERDATIN is data (DAQD*/A = 0), or address (DAQD*/A = 1) information.
- Pin 29 is SLOT0SEL* and is equivalent to the SCXIbus INTR* line. Pin 29 indicates whether the data on the SERDATIN line is being sent to Slot 0 (SLOT0SEL* = 0) or to a module (SLOT0SEL* = 1).
- Pins 24 and 33 are the digital ground references for the data acquisition board digital signals and are tied to the module digital ground.
- Pin 37, SERCLK, is equivalent to the SCXIbus SPICLK line and clocks the serial data on the SERDATIN line into the module registers.

The digital output signal is pin 26:

- Pin 26 is SERDATOUT and is equivalent to the SCXIbus MISO line when jumper W5 is in position 3.

Timing Requirements and Communication Protocol

Timing Signal

The data acquisition timing signal is SCANCLK.

SCANCLK increments MUXCOUNTER on its rising edge. Figure 2-9 shows the timing requirements of the SCANCLK signal that ensure that SCANCLK is properly transmitted over TRIG0.

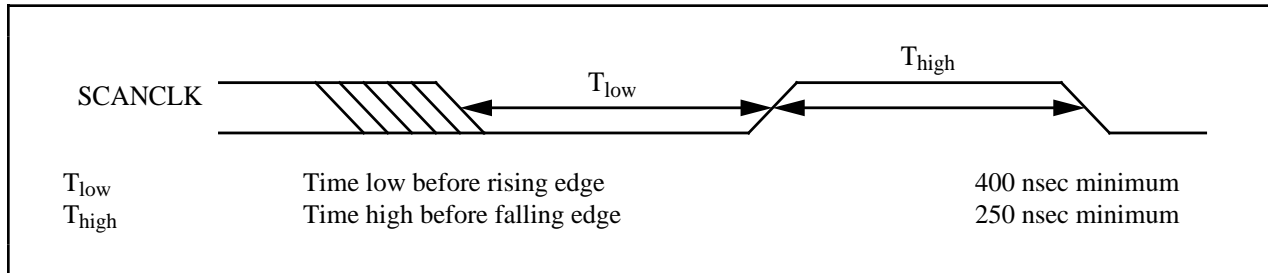

Figure 2-9. SCANCLK Timing Requirements

For settling time specifications, refer to Appendix A, *Specifications*.

Communication Signals

This section describes the methods for communicating on the Serial Peripheral Interface (SPI) bus and their timing requirements. The communication signals are SERDATIN, DAQD*/A, SLOT0SEL*, SERDATOUT, and SERCLK. Furthermore, Slot 0 produces SS* according to data acquisition board programming, so this section also describes SS* timing relationships. For more information on the Slot 0 Slot-Select Register, consult Chapter 4, *Register Descriptions*.

The data acquisition board writes a slot-select number to Slot 0 to determine to which slot the board will talk. In the case of an SCXI-1001 chassis, this write also determines to which chassis the data acquisition board will talk. Writing a slot-select number also programs the Slot 0 hardscan circuitry. See Chapter 5, *Programming*, for information on programming the Slot 0 hardscan circuitry.

Use the following procedure to select a slot in a particular chassis. Figure 2-10 illustrates the timing of this procedure with the example case of selecting Slot 11 in Chassis 9. Notice that the factory-default chassis address for the SCXI-1000 is address 0. For information on changing the address of your chassis, consult the *SCXI-1000/1001 User Manual*. An SCXI-1000 chassis responds to any chassis number.

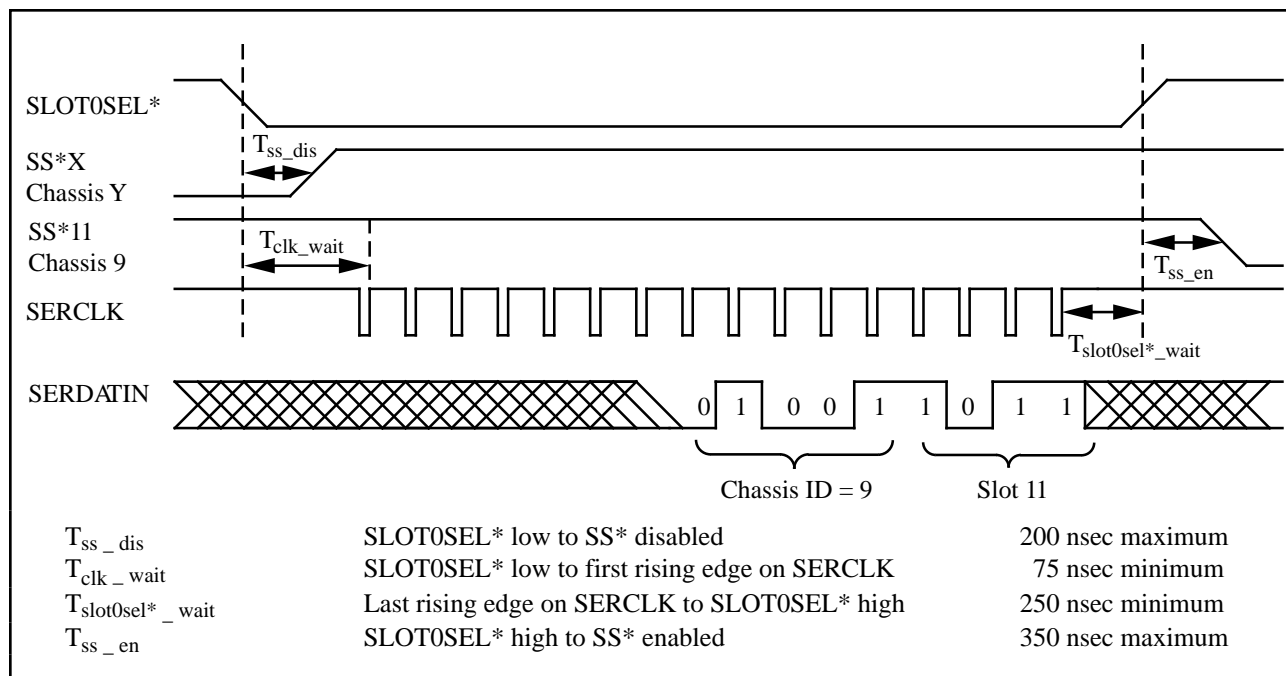

Figure 2-10. Slot-Select Timing Diagram

To write the 16-bit slot-select number to Slot 0, perform the following steps:

1. Initial conditions:

SERDATIN = don't care.
 DAQD*/A = don't care.
 SLOT0SEL* = 1.
 SERCLK = 1.

2. Clear SLOT0SEL* to 0. This deasserts all SS* lines to all modules in all chassis.
3. For each bit, starting with the MSB, perform the following actions:
 - a. Set SERDATIN = bit to be sent. These bits are the data that is being written to the Slot-Select Register.
 - b. Clear SERCLK to 0.
 - c. Set SERCLK to 1. This rising edge clocks the data.
4. Set SLOT0SEL* to 1. This asserts the SS* line of the module whose slot number was written to Slot 0. If you are using multiple chassis, only the appropriate slot in the chassis whose address corresponds to the written chassis number is selected. When no communication is taking place between the data acquisition board and any modules, write zero to the Slot-Select Register to ensure that no accidental writes occur.

Figure 2-11 shows the timing requirements on the SERCLK and SERDATIN signals. You must observe these timing requirements for all communications. T_{delay} is a specification of the SCXI-1100.

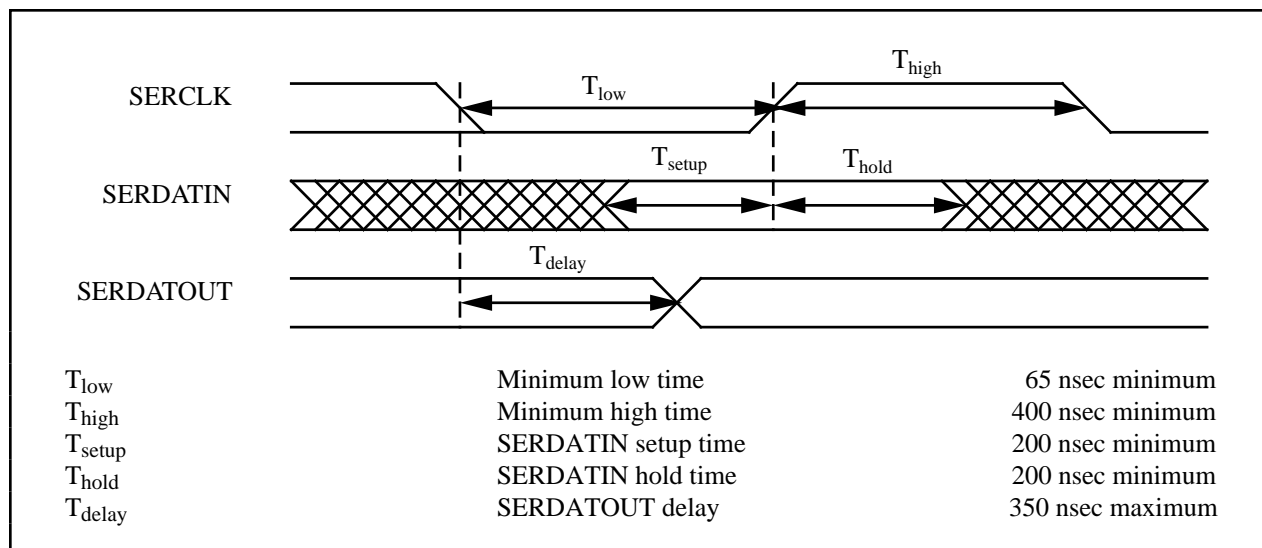

Figure 2-11. Serial Data Timing Diagram

After the Slot-Select line to an SCXI-1100 has been asserted, you can write to the module Configuration Register and read from the Module ID Register using the following protocols. Deassert Slot-Select to reinitialize the contents of the Module ID Register. After the 32 bits of data are read from the Module ID Register, further data will be zeros until reinitialization occurs.

To write to the Configuration Register, perform the following steps:

1. Initial conditions:

- SS* asserted low.
- SERDATIN = don't care.
- DAQD*/A = 0 (indicates data will be written to the Configuration Register).
- SLOT0SEL* = 1.
- SERCLK = 1 (and has not transitioned since SS* went low).

2. For each bit to be written:

- Establish the desired SERDATIN level corresponding to this bit.
- Clear SERCLK to 0.
- Set SERCLK to 1. Clock the data.

3. Pull SLOT0SEL* low to deassert the SS* line and establish conditions for writing a new slot-select number to the Slot 0 Slot-Select Register.

4. If you are not selecting another slot, write zero to the Slot 0 Slot-Select Register.

Figure 2-12 illustrates a write to the SCXI-1100 Configuration Register of the binary pattern:

00010010 10011111 00000111

Chapter 3

Theory of Operation

This chapter contains a functional overview of the SCXI-1100 module and explains the operation of each functional unit making up the SCXI-1100.

Functional Overview

The block diagram in Figure 3-1 illustrates the key functional components of the SCXI-1100. Figure 3-2 shows the detailed block diagram.

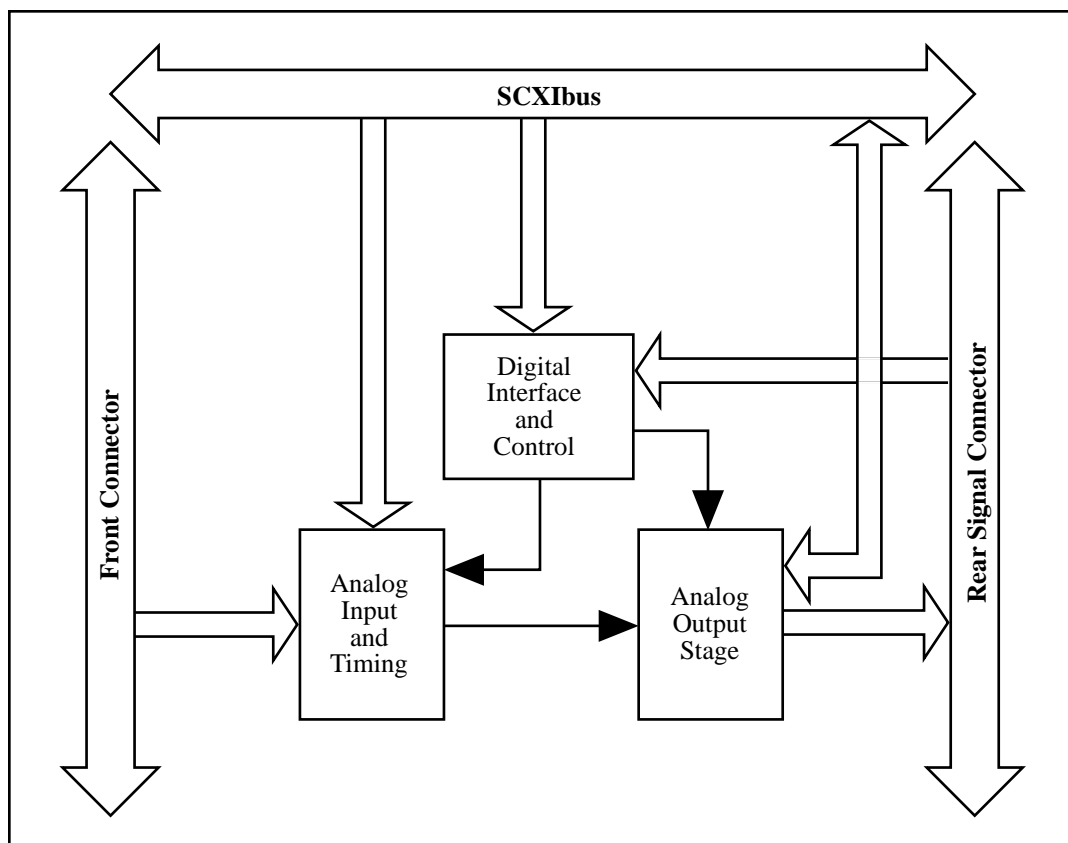

Figure 3-1. SCXI-1100 Block Diagram

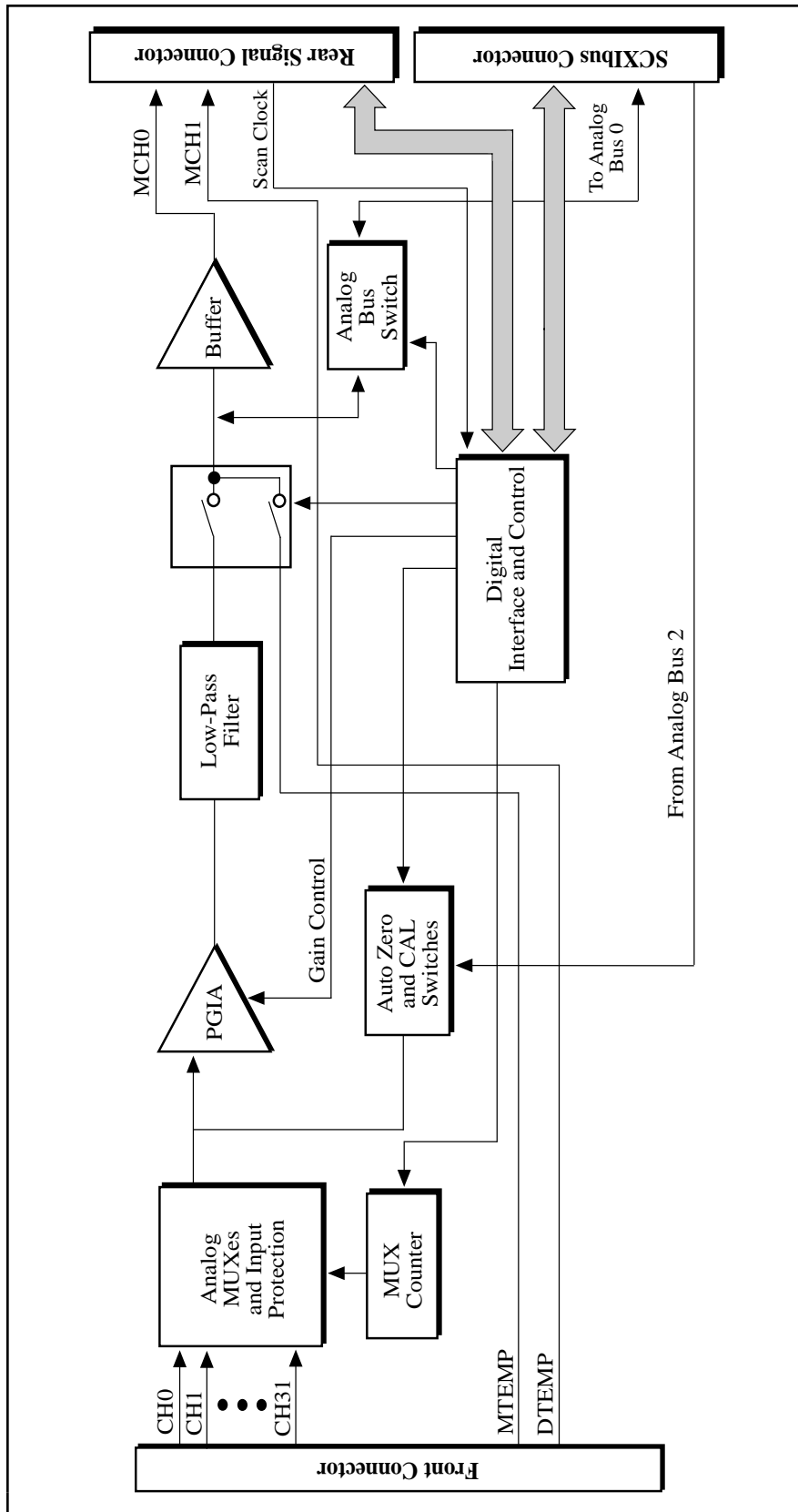

Figure 3-2. SCXI-1100 Detailed Block Diagram

The major components of the SCXI-1100 are as follows:

- The SCXIbus connector
- The digital interface
- The digital control circuitry
- The timing and analog circuitry

The SCXI-1100 consists of eight CMOS four-to-one dual multiplexers for a total of 32 differential channels and a PGIA with gains of 1, 2, 5, 10, 20, 50, 100, 200, 500, 1,000, and 2,000. The SCXI-1100 also has a digital section for automatic control of channel scanning, gain selection, amplifier output selection, MUXCOUNTER clock selection, calibration, and auto-zeroing.

The theory of operation for each of these components is explained in the remainder of this chapter.

SCXIbus Connector

Figure 3-3 shows the pinout of the SCXIbus connector.

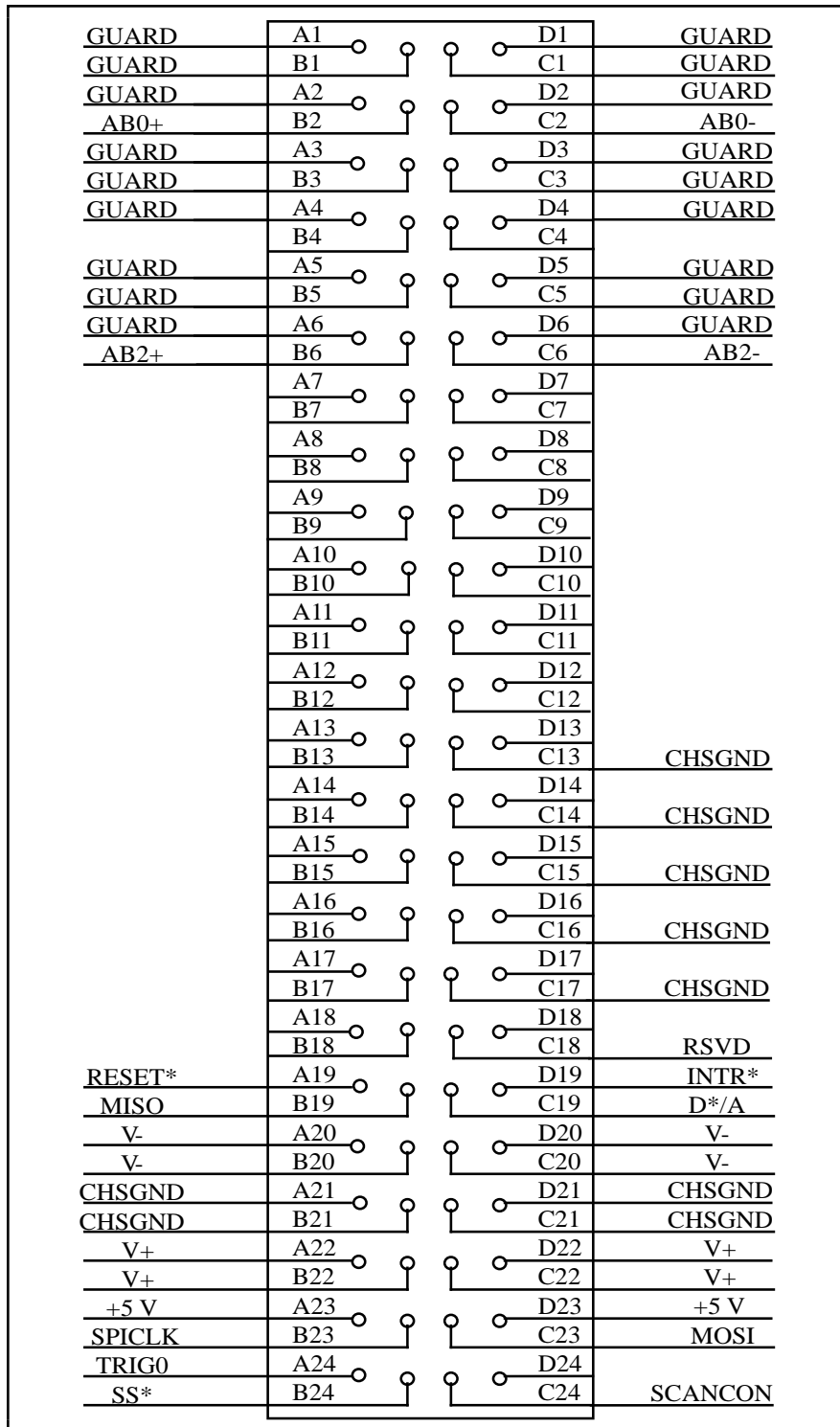

Figure 3-3. SCXIBus Connector Pin Assignment

SCXIBus Connector Signal Descriptions

Pin	Signal Name	Description
A1, B1, C1, D1, A2, D2, A3, B3, C3, D3, A4, D4, A5, B5, C5, D5, A6, D6	GUARD	Guard – Shield and guard the analog bus lines from noise.
B2	AB0+	Analog Bus 0+ – Positive analog bus 0 line. Used to multiplex several modules to one analog signal.
C2	AB0-	Analog Bus 0- – Negative analog bus 0 line. Used to multiplex several modules to one analog signal.
B6	AB2+	Analog Bus 2+ – Positive analog bus 2 line. Refer to the <i>Calibration</i> section later in this chapter for information on the use of this pin.
C6	AB2-	Analog Bus 2- – Negative analog bus 2 line. Refer to the <i>Calibration</i> section later in this chapter for information on the use of this pin.
C13-C17, A21, B21, C21, D21	CHSGND	Chassis Ground – Digital and analog ground reference.
C18	RSVD	Reserved.
A19	RESET*	Reset – When pulled low, reinitializes the module to its power-up state. Totem pole. Input.
B19	MISO	Master-In-Slave-Out – Transmits data from the module to the SCXIBus. Open collector. I/O.
C19	D*/A	Data/Address – Indicates to the module whether address information or data information is being sent to the module on MOSI. Open collector. I/O.
D19	INTR*	Interrupt – Active low. Causes data that is on MOSI to be written to the Slot-Select Register in Slot 0. Open collector. Output.
A20, B20, C20, D20	V-	Negative Analog Supply – -18.5 V to -25 V.
A22, B22, C22, D22	V+	Positive Analog Supply – +18.5 V to +25 V.
A23, D23	+5 V	+5 VDC Source – Digital power supply.

Pin	Signal Name	Description (continued)
B23	SPICLK	Serial Peripheral Interface (SPI) Clock – Clocks the serial data on the MOSI and MISO lines. Open collector. I/O.
C23	MOSI	Master-Out-Slave-In – Transmits data from the SCXIBus to the module. Open collector. I/O.
A24	TRIG0	TRIG0 – General-purpose trigger line that the SCXI-1100 uses to send SCANCLK to other modules or receive SCANCLK from other modules. Open collector. I/O.
B24	SS*	Slot Select – When low, enables module communications over the SCXIBus. Totem pole. Input.
C24	SCANCON	Scanning Control – Combination output enable and reload signal for scanning operations. Totem pole. Input.

* Indicates active low

All other pins are not connected.

MOSI, MISO, SPICLK, and SS* form a synchronous communication link that conforms with SPI using an idle-high clock and second-edge data latching. D*/A, INTR*, and RESET* are additional control signals.

When the module is installed in an SCXI-1000 or SCXI-1001 chassis, the data acquisition board, via the module rear signal connector, must tap into the open-collector backplane signal lines as a master to write to the module. Table 3-1 shows the signal connections from the rear signal connector to the backplane.

Table 3-1. SCXIBus Equivalents for the Rear Signal Connector

Rear Signal Connector Signal	SCXIBus Equivalent
SERDATIN DAQD*/A SLOT0SEL*	MOSI D*/A INTR* You must set jumper W11 to position A (Revision A and B modules only)
SERCLK SERDATOUT	SPICLK MISO You must set jumper W5 to position 3

The SCXI-1100 module converts the data acquisition board signals to open-collector signals on the backplane of the SCXI chassis. For the data acquisition board to talk to a slot, the board must first assert the SS* for that slot. This is done by asserting INTR* low, writing a 16-bit number over MOSI corresponding to the desired slot (and chassis if you are using an SCXI-1001

chassis), and then releasing INTR* high. At this point, the SS* of the desired slot is asserted low and the data acquisition board can communicate with the module in that slot according to the SPI protocol.

Digital Interface Circuitry

Figure 3-4 shows a diagram of the SCXI-1100 and SCXIBus digital interface circuitry.

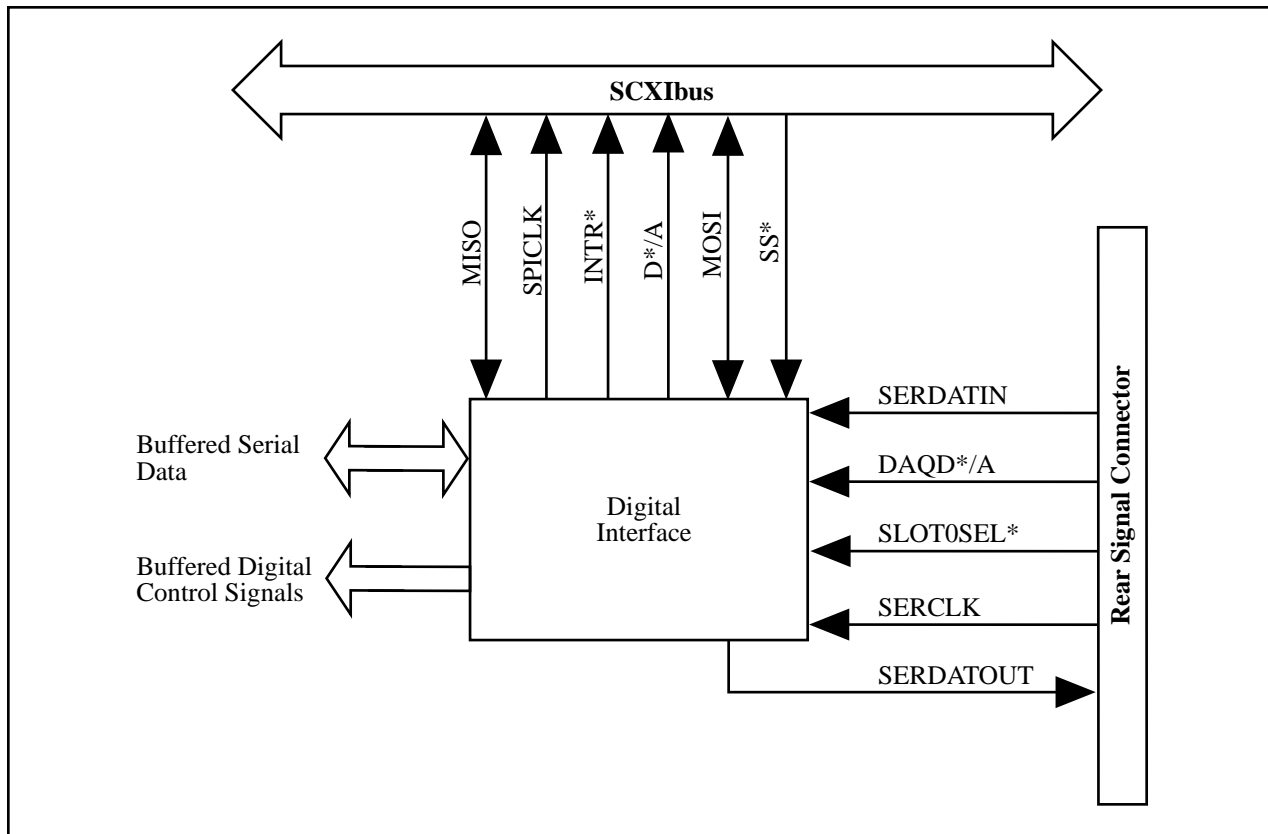

Figure 3-4. Digital Interface Circuitry Block Diagram

The digital interface circuitry is divided into a data acquisition section and an SCXIBus section. The SCXI-1100 connects to the SCXIBus via a 4x24 metal receptacle and to the data acquisition board via a 50-pin ribbon-cable header.

Digital Control Circuitry

Figure 3-5 diagrams the SCXI-1100 digital control circuitry.

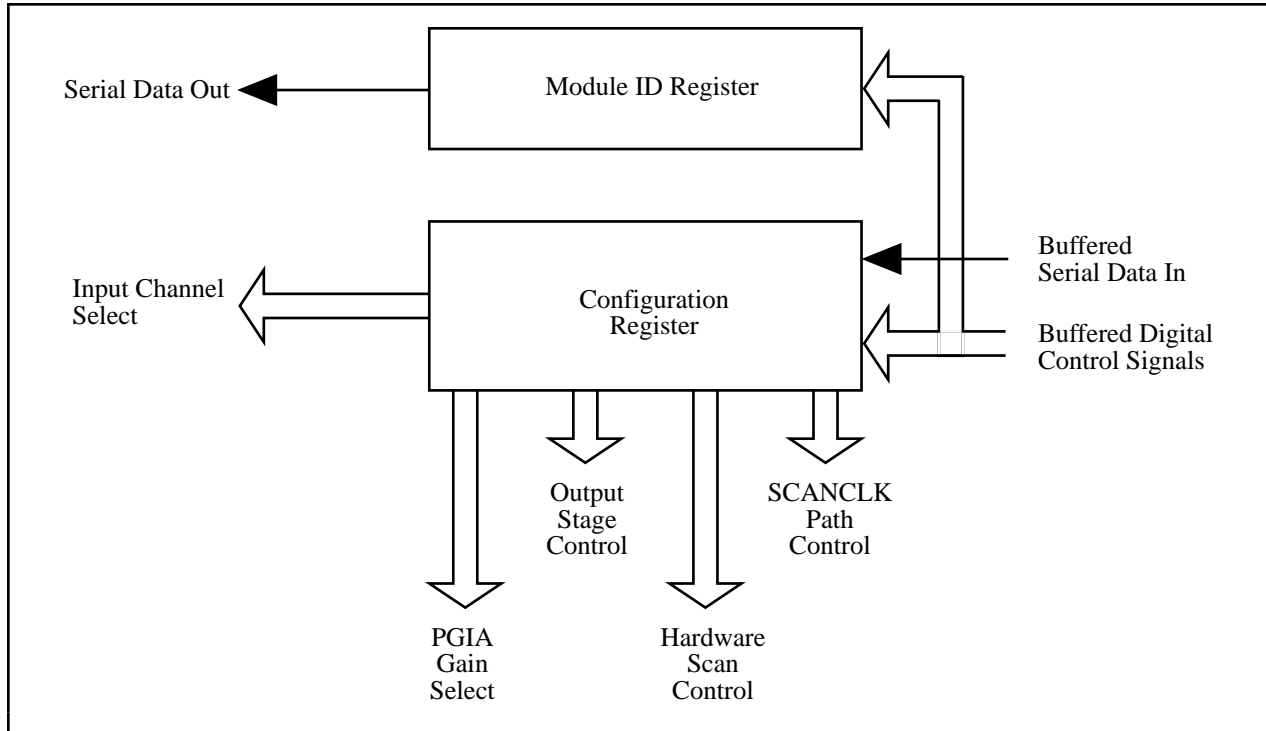

Figure 3-5. SCXI-1100 Digital Control Circuitry

The digital control circuitry section consists of the Configuration Register and the Module ID Register.

The Configuration Register is a 3-byte serial-in parallel-out shift register. Data is received on the MOSI line from either Slot 0 or the data acquisition board when SS^* is enabled and D^*/A indicates data transfer (D^*/A low). You use the Configuration Register for channel, gain, calibration, and auto-zeroing selection, in addition to configuring the SCXI-1100 for scanning options. All the control bits and the gain-select bits feed into a latch before being routed to the rest of the module. The channel-select bits are taken directly from the shift register. Complete descriptions of the register bits are given in Chapter 4, *Register Descriptions*. Writes to the Configuration Register require the following steps:

1. Drive SS^* low to enable communication with the board.
2. Drive D^*/A low to indicate that the information sent on the MOSI line is data.
3. The serial data becomes available on MOSI. $SPICLK$ clocks the data into the register.
4. Drive SS^* high and D^*/A high to indicate an end of communication. This latches the Configuration Register bits.

When you reset the SCXIbus, all bits in the Configuration Register clear.

The Module ID Register connects to MISO on the SCXIbus. The Module ID Register is an 8-bit parallel/serial-in serial-out shift register and an SPI communication adapter. During the first four bytes of transfer after SS^* is asserted low, the contents of the Module ID Register are written onto MISO. Zeros are written to MISO thereafter until SS^* is released and reasserted. The SCXI-1100 module ID is hex 00000006.

Analog and Timing Circuitry

The SCXIbus produces analog power (± 18.5 VDC) that is regulated on the SCXI-1100 to ± 15 VDC, a guard, analog buses ($AB0\pm$, $AB2\pm$) and a chassis ground (CHSGND). $AB0\pm$ buses the SCXI-1100 output to other modules or receives outputs from other modules via the SCXIbus. The module can use $AB2\pm$ to receive a precision voltage for auto calibration of the PGIA. Refer to the *Calibration* section later in this chapter for more information. The guard guards both analog buses. You can connect the guard via jumper W10 to the PGIA ground reference, or leave the guard floating (another board can make a connection).

The data acquisition board analog input and timing is the interface between the SCXI-1100 output and the data acquisition board. This interface is described in the following section.

Analog Input and Timing Circuits

Figure 3-6 diagrams the SCXI-1100 analog input and timing circuitry.

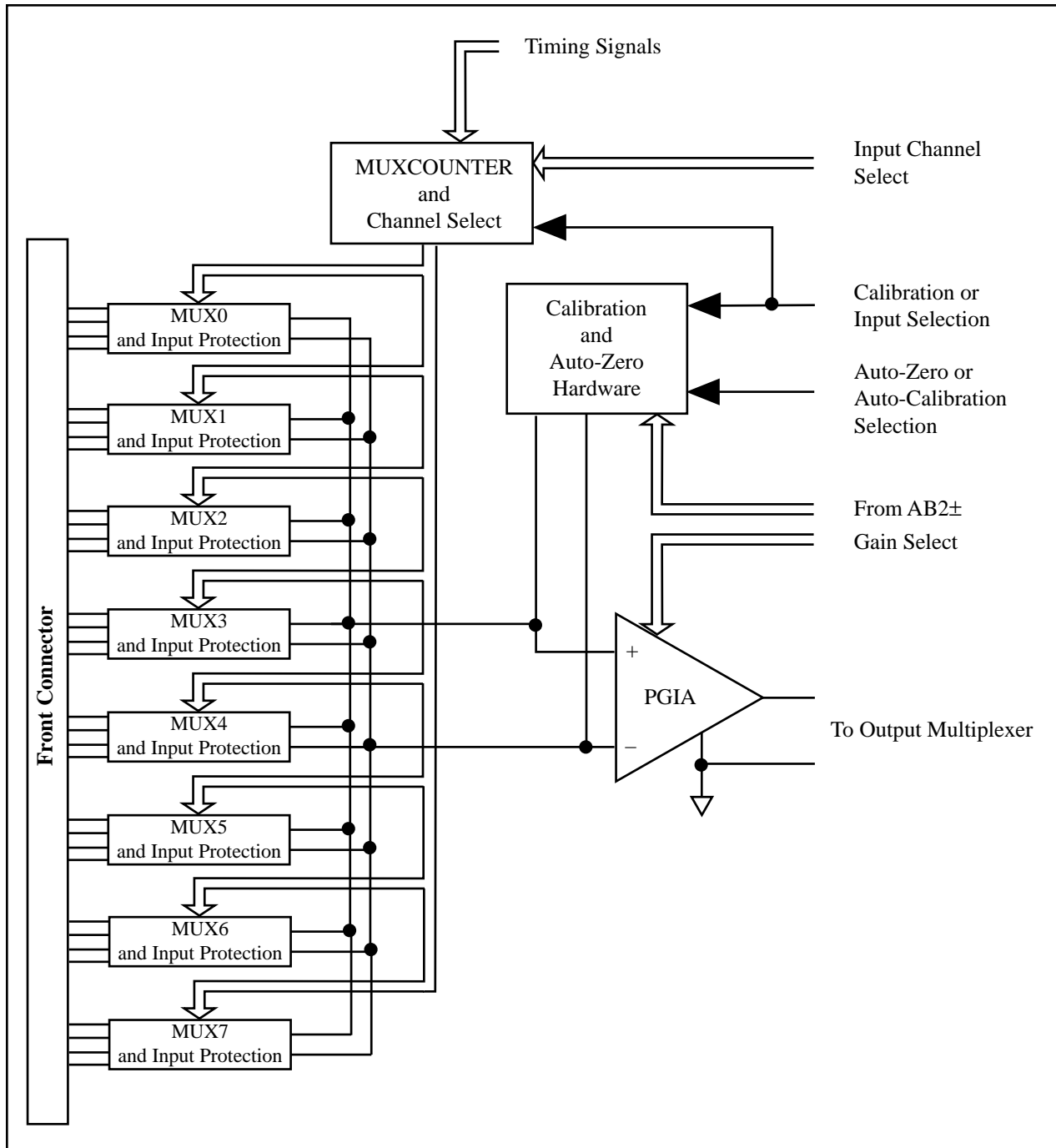

Figure 3-6. Analog Input and Timing Block Diagram

The analog input and timing circuitry consists of an input multiplexer, channel select hardware, a software-programmable gain instrumentation amplifier, and calibration hardware.

The input multiplexer consists of eight CMOS analog input multiplexers and has 32 differential analog input channels. Input channels and multiplexers correspond as shown in Table 3-2.

Table 3-2. Multiplexer/Input Channel Correspondence

Multiplexer	Input Channels
0	0 through 3
1	4 through 7
2	8 through 11
3	12 through 15
4	16 through 19
5	20 through 23
6	24 through 27
7	28 through 31

The analog input overvoltage protection is ± 25 V when powered on and ± 15 V when powered off.

The channel-select hardware consists of a 5-bit counter, MUXCOUNTER, and a three-to-eight decoder. The module sends to the decoder the three MSBs of the counter to determine which multiplexer is addressed, and the two LSBs to determine which of the four channels of the selected multiplexer is to be read. In the Single-Channel Read mode, the module loads the MUXCOUNTER with the desired channel number. In the Scanning mode, the module loads the counter with the first channel to be read. During the scan, the counter is clocked by SCANCLK from the data acquisition board, or TRIG0 from the SCXIbus, depending on the state of the CLKSELECT bit in the Configuration Register. During scanning operations, MUXCOUNTER is reloaded with the channel value stored in the Configuration Register when SCANCON is high (inactive) and counts upwards on each rising clock edge when SCANCON is low (active).

The instrumentation amplifier on the SCXI-1100 board fulfills two purposes. The PGIA converts a differential input signal into a single-ended signal with respect to the SCXI-1100 ground for input common-mode signal rejection. With this conversion, the module can extract the input analog signal from a common-mode voltage or noise before the data acquisition board samples and converts the signal. The instrumentation amplifier also amplifies and conditions an input signal, which results in an increase in measurement resolution and accuracy. Furthermore, software-selectable gains of 1, 2, 5, 10, 20, 50, 100, 200, 1,000, and 2,000 are available through the SCXI-1100 instrumentation amplifier. The instrumentation amplifier is made up of two cascaded stages with independent gain control as described in Chapter 5, *Programming*. The first stage has gains of 1, 10, and 100 and the second stage has gains of 1, 2, 5, 10, and 20. The choice of first-stage and second-stage gains affects the settling time of the PGIA. For example, to achieve a settling time of 5.6 μ s at an overall gain of 100, you must set the first and second stages to 10 and 10 and not to 100 and 1.

The input circuitry also includes two one-pole filters at 4 Hz and 10 kHz. These filters are jumper selectable as described in Chapter 2, *Configuration and Installation*. For further filtering, each input channel has C320-type capacitor pads for differential filtering at each channel. Notice that the filter cut-off frequencies can differ for each channel depending on the capacitor used. You can determine the -3 dB point of these filters from the following equation:

$$f_c = 1/(4\pi R_p C)$$

where R_p is equal to $820 \Omega \pm 2\%$ and C is the capacitor you installed.

Note: In general, f_c may be limited to 20 Hz minimum because of the physical and value requirements of the package type capacitor ($C = 4.7 \mu\text{F}$).

In addition, each input channel has 1/4 W resistor pads. Figure 3-7 shows the locations of these pads. You can transform a given channel into a current-loop receiver by placing an appropriate resistor into these pads. You can purchase SCXI process-current packs (resistor kits) separately from National Instruments. Refer to Chapter 2, *Configuration and Installation*, for detailed installations of these capacitors and resistors.

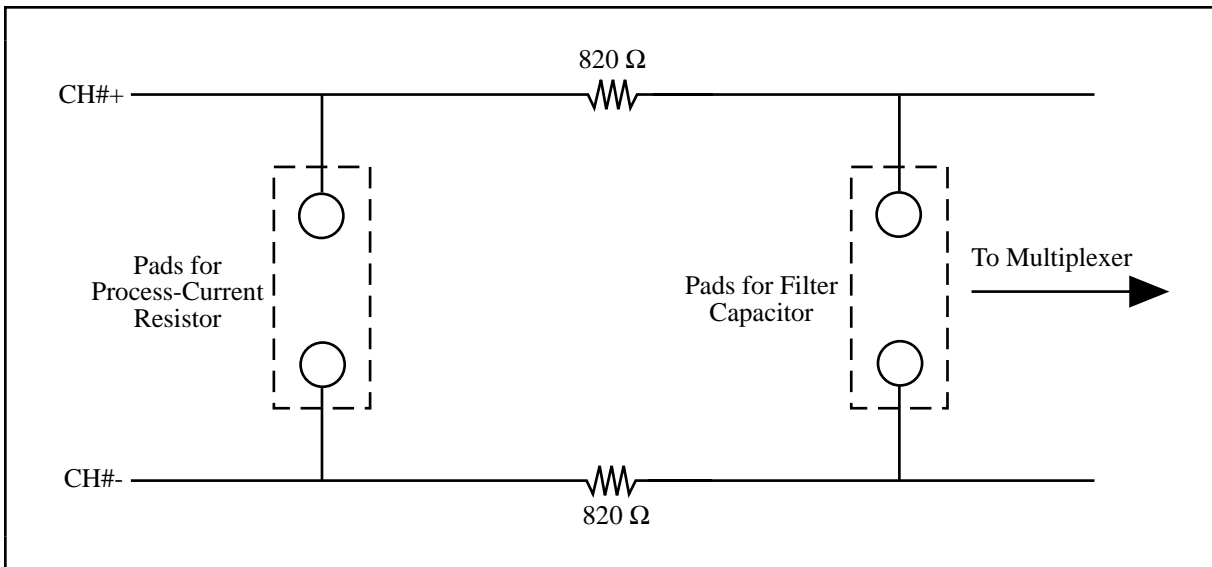

Figure 3-7. Pad Locations

Refer to the *Input Filtering and Current Loop Resistors* section in Chapter 2, *Configuration and Installation*, for more information.

Calibration

The calibration hardware consists of two single-pole double-throw (SPDT) switches. After you select the Calibration mode, the input multiplexers are disabled and the PGIA inputs are connected to the calibration switches. After you select the Calibration mode, clearing the CV/ZERO* bit of the Configuration Register to 0 will ground the PGIA inputs. This procedure is referred to as auto-zeroing. When you set the CV/ZERO* bit to 1, the PGIA inputs connect to $AB2\pm$ of the SCXIbus, on which you can send a precision voltage. This procedure, referred to as auto-calibration, is reserved for use with future products.

Auto-zeroing and auto-calibration are methods for nullifying error sources that compromise the quality of measurements. Auto-zeroing determines the amount of offset at the output of the SCXI-1100 at a given PGIA gain. You should perform auto-zeroing at the start of an experiment

for each gain you use to eliminate error caused by drift in the PGIA internal circuitry and to increase the accuracy of the measurement. After you determine the offset, you can determine the analog input as follows:

$$V_{in} = (V_{out} - V_{ofs})/G_{PGIA}$$

where V_{in} is the analog input voltage, G_{PGIA} is the PGIA gain, V_{out} is the SCXI-1100 output, and V_{ofs} is the measured offset voltage at the gain G_{PGIA} .

Notice that the auto-zero path is different from the analog input path; therefore, even after auto-zeroing, a residual input offset still exists and has a value of less than 5 μV .

Inherently, the SCXI-1100 offsets and gain errors are small, as shown in Appendix A, *Specifications*; therefore, hardware calibration is not necessary and the software calibration procedure explained in the previous paragraph is adequate.

Analog Output Circuitry

Figure 3-8 diagrams the SCXI-1100 analog output circuitry.

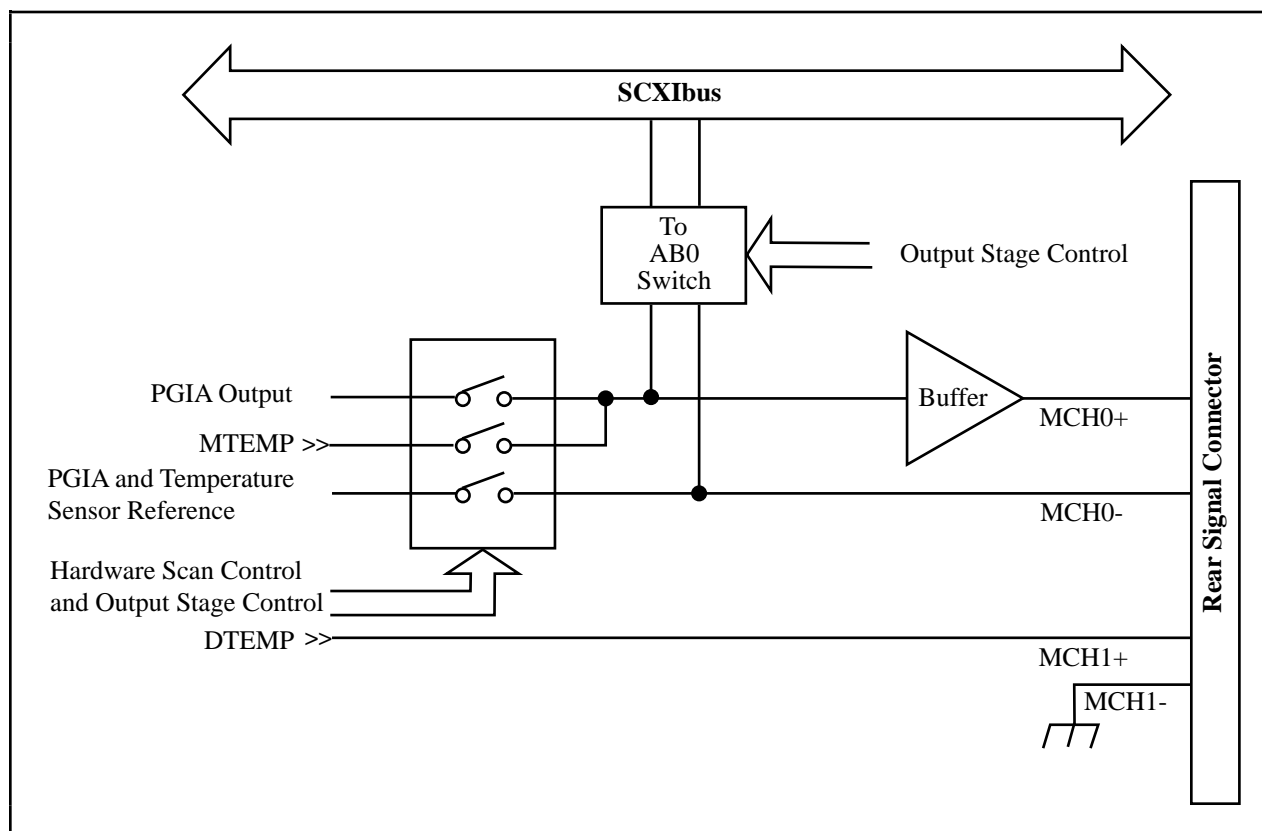

Figure 3-8. Analog Output Circuitry

The SCXI-1100 output circuitry consists of an output multiplexer that multiplexes the PGIA output and the temperature sensor reading on the MTEMP line. To read the temperature sensor

when it is multiplexed with the other input channels, set the RTEMP bit of the Configuration Register high. This measurement is only software controlled. For hardware control of the temperature sensor reading, connect the temperature sensor to MCH1+. Notice that MCH1-, the DTS reference, is hardwired to the chassis ground. The multiplexer output connects to the MCH0± and is connected to the data acquisition board analog channel input. On MIO boards, the MCH0± on the rear signal connector directly connects to ACH0 and ACH8. Furthermore, you can bus the multiplexed output of the SCXI-1100 via switches to AB0± on the SCXIbus to other modules. When you use multiple modules, you can bus the outputs of the module via AB0 to the module that connects to the data acquisition board. In this case, the AB0 switches of all the modules are closed, whereas the output multiplexers of all the modules but the one being read are disabled. Refer to Chapter 2, *Configuration and Installation*, and Chapter 5, *Programming*, for further details on how to configure and program multiple modules. The SCXI-1100 outputs on the rear signal connector are short-circuit protected.

Scanning Modes

The SCXI-1100 has three basic types of Scanning modes—single-module multiplexed scanning, multiple-module multiplexed scanning, and multiple-chassis scanning, which is possible only with the SCXI-1001 chassis. Only the MIO boards can scan the SCXI-1100. Notice, however, that for many applications, such as reading temperatures, you can read channels at speeds high enough to simulate scanning. In these cases, the Lab boards or the PC-LPM-16 board may be sufficient. For additional information, consult either Chapter 2, *Configuration and Installation*, Chapter 5, *Programming*, your data acquisition board user manual, or the SCXI chassis user manual. If you need more information, contact National Instruments.

During scanning, a module sends the SCANCLK signal to Slot 0 over the TRIG0 backplane line, and Slot 0 sends the SCANCON signal to the modules. Use this timing signal to reload the MUXCOUNTER and to determine when the SCXI-1100 output is enabled. Slot 0 contains a module scan list FIFO (first-in-first-out memory chip) similar to the Channel/Gain FIFO on an MIO board, except that instead of having a channel number and gain setting for each entry, it contains a slot number and a sample count for each entry. The list in Slot 0 determines which module to access and for how many samples. Make sure that the lists on the data acquisition board and Slot 0 are compatible so that the samples are acquired as intended. See your SCXI chassis manual for more information.

Single-Module Multiplexed Scanning

Single-Module Multiplexed Scanning (Direct)

This is the simplest scanning mode. Directly cable the SCXI-1100 to the data acquisition board as shown in Figure 3-9. The module sends SCANCLK onto TRIG0, and Slot 0 sends SCANCON back to the module. SCANCON is low at all times during the scan except during changes from one Slot 0 scan list entry to the next, when SCANCON pulses high to make the MUXCOUNTER reload its starting channel. Notice that although you are using only a single module, you can put many entries with different counts in the Slot 0 FIFO, so that some channels are read more often than others. You cannot change the start channel in the module Configuration Register during a scan.

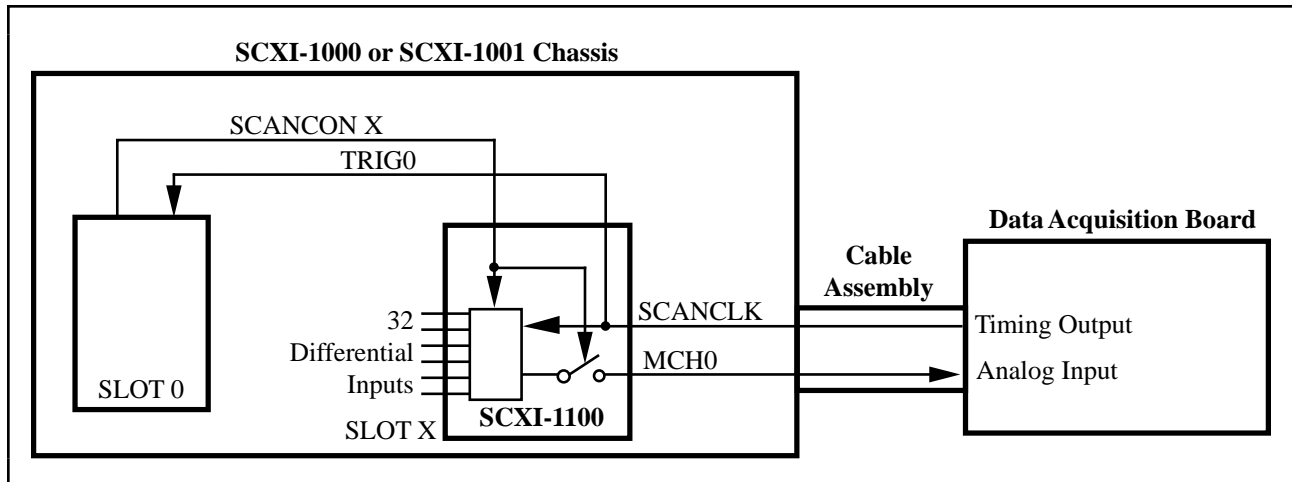

Figure 3-9. Single-Module Multiplexed Scanning (Direct)

Single-Module Multiplexed Scanning (Indirect)

In this mode, do not directly cable the SCXI-1100 to the data acquisition board. Instead, connect another module to the data acquisition board; the analog output of the SCXI-1100 is sent over Analog Bus 0, through the intermediate module, and then to the data acquisition board. The SCXI-1100 receives its MUXCOUNTER clock from TRIG0, which the intermediate module sends, as shown in Figure 3-10. Slot 0 operation is the same for direct connection scanning.

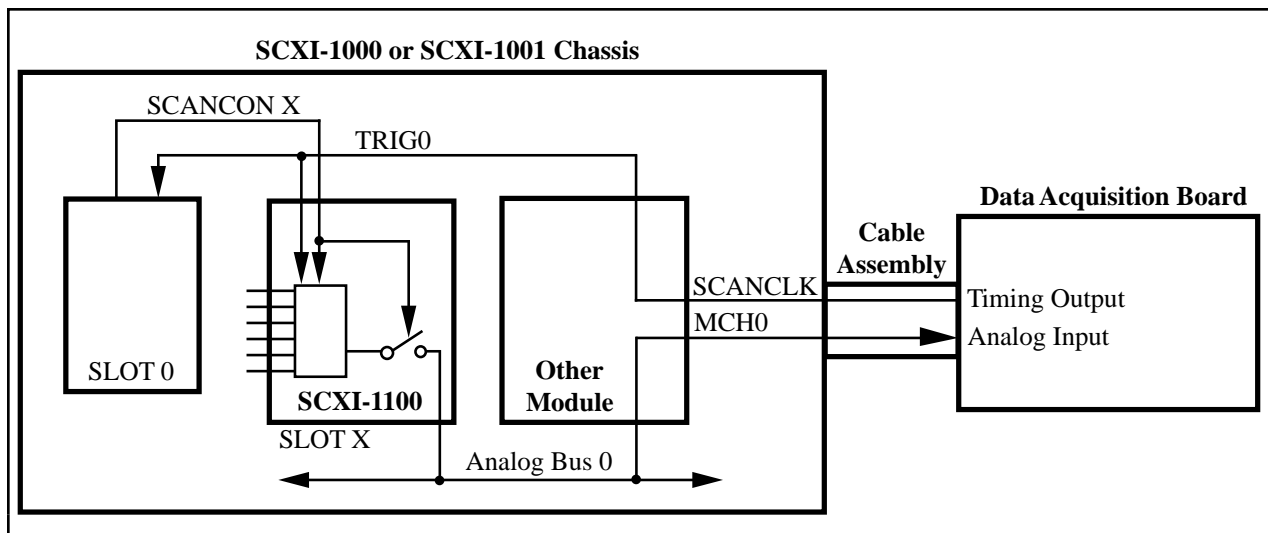

Figure 3-10. Single-Module Multiplexed Scanning (Indirect)

Multiple-Module Multiplexed Scanning

In this mode, all the modules tie into Analog Bus 0, and SCANCON enables the output of their amplifiers. The module that is directly cabled to the data acquisition board sends SCANCLK onto TRIG0 for the other modules and Slot 0, as shown in Figure 3-11. Program the scan list in Slot 0 with the sequence of modules and the number of samples per entry.

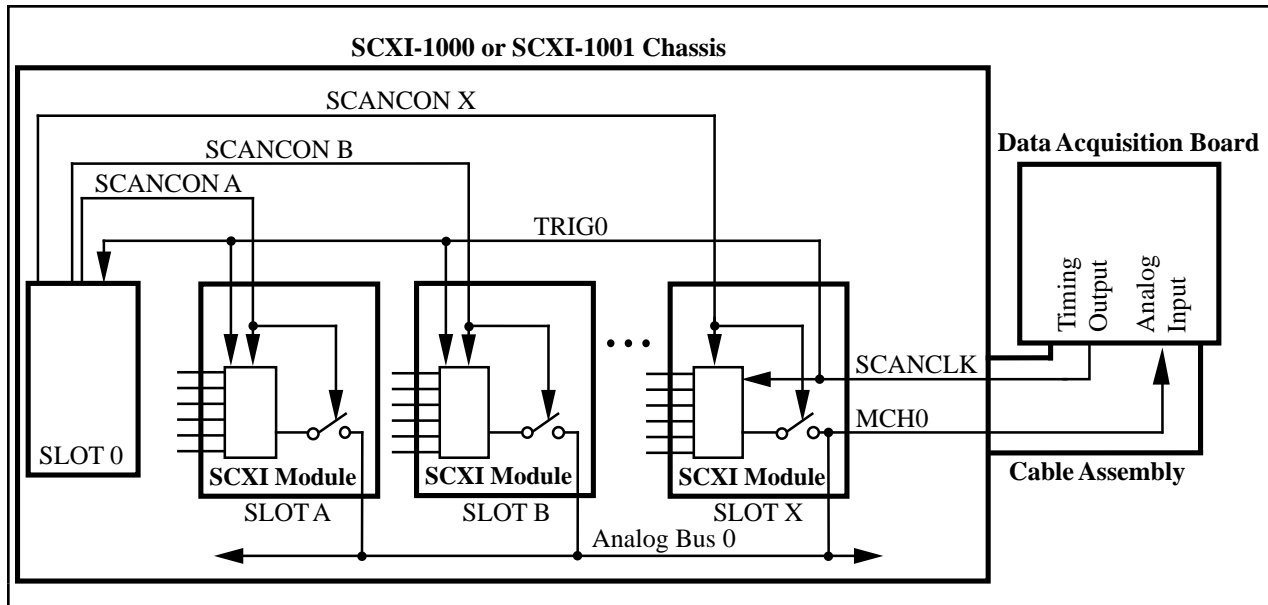

Figure 3-11. Multiple-Module Multiplexed Scanning

Multiple-Chassis Scanning

In this mode, you attach each SCXI-1001 chassis to a daisy chain of cable assemblies and multichassis adapter boards, as shown in Figure 3-12. Program each chassis separately; each chassis occupies a dedicated channel of the data acquisition board. Within each chassis, scanning operations act as if the other chassis are not being used, with one exception—you must program the Slot 0 scan list in each chassis with dummy entries of Slot 13 to fill the samples when the data acquisition board will be sampling another chassis or data acquisition board channel. This keeps the chassis synchronized. Notice that you can only perform multiple-chassis scanning with the SCXI-1001 chassis and MIO boards. See Chapter 5, *Programming*, for more information on multiple-chassis scanning. See Appendix E, *SCXI-1100 Cabling*, for more information on the necessary cable accessories for multiple-chassis scanning.

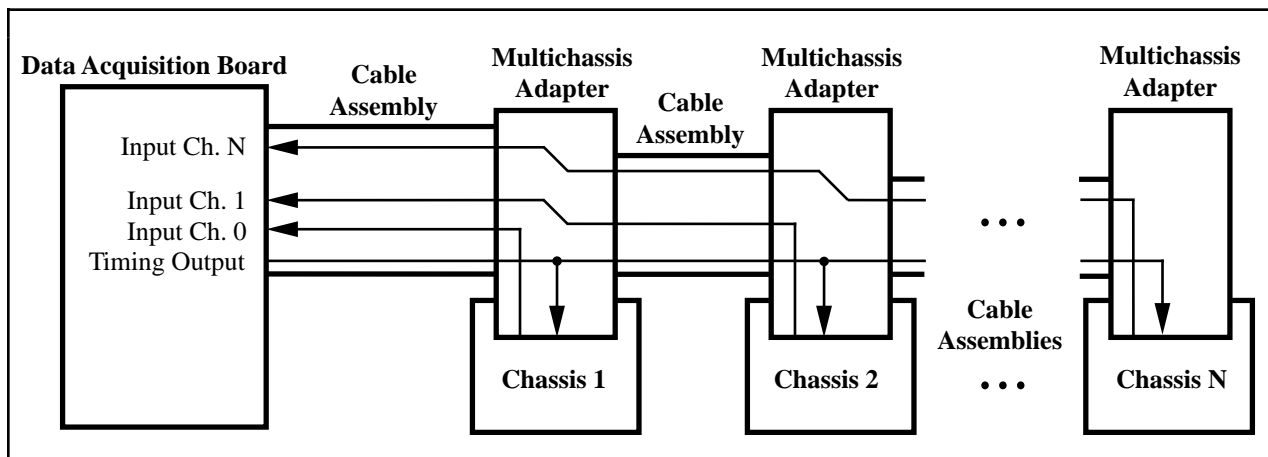

Figure 3-12. Multiple-Chassis Scanning

Chapter 4

Register Descriptions

This chapter describes in detail the SCXI-1100 Module ID Register, the Configuration Register, the Slot 0 registers, and multiplexer addressing.

Note: If you plan to use a programming software package such as NI-DAQ, LabWindows, or LabVIEW with your SCXI-1100 module, you do not need to read this chapter.

Register Description

Register Description Format

This register description chapter discusses each of the SCXI-1100 registers and the Slot 0 registers. A detailed bit description of each register is given. The individual register description gives the type, word size, and bit map of the register, followed by a description of each bit.

The register bit map shows a diagram of the register with the MSB shown on the left (bit 15 for a 16-bit register, bit 7 for an 8-bit register), and the LSB shown on the right (bit 0). A rectangle is used to represent each bit. Each bit is labeled with a name inside its rectangle. An asterisk (*) after the bit name indicates that the bit is inverted (negative logic). The Module ID register has a unique format and is described in the *Module ID Register* section.

In many of the registers, several bits are labeled with an X, indicating don't care bits. When you write to a register, you may set or clear these bits without effect.

SCXI-1100 Register Descriptions

The SCXI-1100 has two registers. The Module ID Register is a 4-byte read-only register that contains the Module ID number of the SCXI-1100. The Configuration Register is a 24-bit write-only register that controls the functions and characteristics of the SCXI-1100.

Module ID Register

The Module ID Register contains the 4-byte module ID code for the SCXI-1100. Whenever the module is accessed, the module ID code number is read as the first four bytes on the MISO line. The bytes appear least significant byte first. Within each byte, data is sent out MSB first. Additional data transfers result in all zeros being sent on the MISO line. The Module ID Register is reinitialized to its original value each time the SCXI-1100 is deselected by the SS* signal on the backplane.

Type: Read-only

Word Size: Four-byte

Bit Map:

Byte 0							
7	6	5	4	3	2	1	0
0	0	0	0	0	1	1	0

Byte 1							
7	6	5	4	3	2	1	0
0	0	0	0	0	0	0	0

Byte 2							
7	6	5	4	3	2	1	0
0	0	0	0	0	0	0	0

Byte 3							
7	6	5	4	3	2	1	0
0	0	0	0	0	0	0	0

Configuration Register

The Configuration Register contains 24 bits that control the functions of the SCXI-1100. When SS* is asserted (low) and D*/A indicates data (low), the register shifts in the data present on the MOSI line, bit 23 first, and then latches it when the SCXI-1100 is deselected by the SS* signal on the backplane. The Configuration Register initializes to all zeros when the SCXI chassis is reset or first turned on.

Type: Write-only

Word Size: 24-bit

Bit Map:

23	22	21	20	19	18	17	16
X	X	X	GAIN4	GAIN3	GAIN2	GAIN1	GAIN0
15	14	13	12	11	10	9	8
CLKOUTEN	CLKSELECT	X	CHAN4	CHAN3	CHAN2	CHAN1	CHAN0
7	6	5	4	3	2	1	0
CAL/ENM*	CV/ZERO*	RTEMP	RSVD	SCANCLKEN*	SCANCONEN	ABOEN	FOUTEN*

Bit	Name	Description
23-21, 13	X	Don't care bits – Unused.
20-16	GAIN<4..0>	Gain Select – Determine the gains of the first and second stages of the PGIA. The total gain of the amplifier combination is the product of the first-stage gain and the second-stage gain. If an invalid bit pattern is programmed, the gain of the amplifier stage becomes the open-loop gain of the amplifier and the output of the SCXI-1100 saturates. The following table describes the amplifier gains:

Bit 17	Bit 16	First-Stage Gain
0	0	1
0	1	10
1	0	100
1	1	not valid (open loop)

Bit	Name	Description (continued)
-----	------	-------------------------

Bit 20	Bit 19	Bit 18	Second-Stage Gain
0	0	0	1
0	0	1	2
0	1	0	5
0	1	1	10
1	0	0	20
1	0	1	not valid (open loop)
1	1	0	not valid (open loop)
1	1	1	not valid (open loop)

15	CLKOUTEN	Scan Clock Output Enable – Determines whether the SCANCLK signal from the rear signal connector is sent out, in inverted form, to the TRIG0 backplane signal. If CLKOUTEN is set to 1, SCANCLK* is transmitted on TRIG0. If CLKOUTEN is cleared to 0, SCANCLK* is not transmitted on TRIG0.
14	CLKSELECT	Scan Clock Select – Determines whether the SCXI-1100 uses SCANCLK or the inverted form of TRIG0 to clock the MUXCOUNTER for the purposes of scanning through the analog channels. If CLKSELECT is cleared to 0, SCANCLK clocks MUXCOUNTER. If CLKSELECT is set to 1, TRIG0* is the source that clocks MUXCOUNTER.
12-8	CHAN<4..0>	Channel Select – Determine the channel number (0 to 31) that is loaded into the MUXCOUNTER to determine the analog channel to be read during a single read, or the starting channel on the module for a scanned data acquisition. CHAN4 is the MSB.
7	CAL/ENM*	Calibration/Multiplexer Select – Along with CV/ZERO* and the output of the MUXCOUNTER, determines the source of the analog signal that is sent to the PGIA. If CAL/ENM* is cleared to 0, the PGIA inputs are the multiplexer outputs that MUXCOUNTER determines. If CAL/ENM* is set to 1, the PGIA inputs are either grounded or connected to Analog Bus 2 of the SCXibus backplane, as determined by the CV/ZERO* bit.
6	CV/ZERO*	Calibration Voltage/Zero Select – When CAL/ENM* is set to 1, determines whether the PGIA inputs are grounded or connected to Analog Bus 2. When CV/ZERO* is cleared to 0, the PGIA inputs are grounded. When CV/ZERO* is set to 1, the PGIA inputs are connected to Analog Bus 2.

Bit	Name	Description (continued)
5	RTEMP	Read Temperature – Determines whether the PGIA output or the MTEMP signal is driven onto the MCH0± pins of the rear signal connector. If RTEMP is cleared to 0, the PGIA output is used as the module output. If RTEMP is set to 1, the MTEMP signal is the module output. The module output is driven only when FOUTEN* is cleared to 0 or SCANCON is active (low) while SCANCONEN* is cleared.
4	RSVD	Reserved – Should always be written to 0.
3	SCANCLKEN*	Scan Clock Enable – Determines whether MUXCOUNTER will increment on each clock signal (the clock source is determined by CLKSELECT) or keep its loaded value. If SCANCLKEN* is cleared to 0, MUXCOUNTER will be clocked during scans. If SCANCLKEN* is set to 1, MUXCOUNTER will not be clocked.
2	SCANCONEN	Scan Control Enable – When set to 1, enables the SCANCON signal.
1	AB0EN	Analog Bus 0 Enable – Determines whether Analog Bus 0 on the SCXIbus drives MCH0 on the rear signal connector. If AB0EN is cleared to 0, Analog Bus 0 does not drive MCH0. If AB0EN is set to 1, Analog Bus 0+ drives MCH0+ through a buffer and Analog Bus 0- is connected to MCH0-.
0	FOUTEN*	Forced Output Enable – Determines whether the module drives the MCH0± pins on the rear signal connector with either the PGIA output or the MTEMP signal, depending on the state of RTEMP. If FOUTEN* is cleared to 0, the MCH0± pins are driven through a buffer by the PGIA output or the MTEMP line. If FOUTEN* is set to 1, the MCH0± pins are not driven by the PGIA or MTEMP, unless SCANCON is active (low) and the SCANCONEN bit is cleared. If the PGIA or MTEMP is driving the output buffer, FOUTEN* drives Analog Bus 0 if AB0EN is set. If nothing is driving the output buffer, the SCXI-1100 output saturates.

Slot 0 Register Descriptions

Slot 0 has three registers. The Slot-Select Register is a 16-bit write-only register that determines with which slot the data acquisition board speaks when SLOTOSEL* is released high. With the SCXI-1001 chassis, the Slot-Select Register also determines in which chassis the desired slot is. The FIFO Register is a 16-bit write-only register that stores the Slot 0 scan list that determines the chassis scan sequence. The Hardscan Control Register (HSCR) is an 8-bit write-only register that sets up the timing circuitry in Slot 0. The Slot-Select Register is written to over the SLOTOSEL* line. Write to the HSCR and the FIFO Register as if they were registers on modules in Slots 13 and 14. Maintain software copies of the Slot-Select Register, HSCRs, and all the Slot 0 scan lists that correspond to the writes to FIFO Registers.

If you are using multiple chassis, it is important to understand the architectural differences of the Slot-Select Register as compared to the HSCR and the FIFO Register. Although each chassis has its own physical Slot-Select Register, all are written to at the same time. The jumper settings in Slot 0 of a chassis determine with which chassis number Slot 0 is identified. From the software perspective, only one Slot-Select Register exists in a system composed of multiple chassis. The HSCR and FIFO Register, on the other hand, are unique to each chassis, and you must program them separately.

Slot-Select Register

The Slot-Select Register contains 16 bits that determine which module in which chassis is enabled for communication when the SLOTOSEL* line is high. An SCXI-1000 chassis selects the appropriate module in its chassis, regardless of the chassis number written. The Slot-Select Register shifts in the data present on the MOSI line, bit 16 first, when SLOTOSEL* is low.

Type: Write-only

Word Size: 16-bit

Bit Map:

15	14	13	12	11	10	9	8
X	X	X	X	X	X	X	CHS4
7	6	5	4	3	2	1	0
CHS3	CHS2	CHS1	CHS0	SL3	SL2	SL1	SL0

Bit	Name	Description
15-9	X	Don't care bits – Unused.
8-4	CHS<4..0>	Chassis Bit 4 through 0 – Determine which chassis is selected. On the SCXI-1000 chassis, these bits are don't cares.
3-0	SL<3..0>	Slot Bit 3 through 0 – Determine which slot in the selected chassis is selected.

Hardscan Control Register (HSCR)

The HSCR contains eight bits that control the setup and operation of the hardscan timing circuitry of Slot 0. To write to the HSCR, follow the procedure given in the *Register Writes* section in Chapter 5, *Programming*, using 13 as the slot number and writing eight bits to the HSCR. The register shifts in the data present on the MOSI line, bit 7 first, when the Slot-Select Register selects Slot 13.

Type: Write-only

Word Size: 8-bit

Bit Map:

7	6	5	4	3	2	1	0
RSVD	FRT	RD	ONCE	HSRS*	LOAD*	SCANCONEN	CLKEN

Bit	Name	Description
7	RSVD	Reserved.
6	FRT	Forced Retransmit – When cleared to 0, causes the scan list in the FIFO to be reinitialized to the first entry, allowing the scan list to be reprogrammed in two steps instead of having to rewrite the entire list. When this bit is set to 1, it has no effect.
5	RD	Read – When cleared to 0, prevents the FIFO from being read. When set to 1, the FIFO is read except at the end of a scan list entry during scanning, when reading is briefly disabled to advance to the next scan list entry.
4	ONCE	Once – When set to 1, causes the hardscan circuitry to shut down at the end of the scan list circuitry during a data acquisition. When cleared to 0, the circuitry wraps around and continues seamlessly with the first scan list entry after the entry is finished.
3	HSRS*	Hardscan Reset – When cleared to 0, causes all the hardware scanning circuitry, including the FIFO, to be reset to the power-on state. When set to 1, this bit has no effect.
2	LOAD*	Load – When cleared to 0, forces the Slot 0 sample counter to be loaded with the output of the FIFO. When set to 1, this bit has no effect.
1	SCANCONEN	Scan Control Enable – When set to 1, enables the SCANCON lines. When cleared to 0, all SCANCON lines are disabled (high).
0	CLKEN	Clock Enable – When set to 1, enables TRIG0 as a clock for the hardscan circuitry. When cleared to 0, TRIG0 is disabled.

FIFO Register

The FIFO Register adds entries to the Slot 0 FIFO. The FIFO contains the Slot 0 scan list. Each entry contains a slot number to be accessed, and a count number to determine the number of samples to be taken from that slot. To write to the FIFO Register, follow the procedure given in the *Register Writes* section in Chapter 5, *Programming*, using 14 as the slot number and writing 16 bits to the FIFO Register. The register shifts in the data present on the MOSI line, bit 7 first, when the Slot-Select Register selects Slot 14. Consecutive writes to the FIFO Register create the Slot 0 scan list. Each write creates a new entry at the end of the scan list. The maximum number of entries is 256. To clear the FIFO of all entries, clear the HSRS* bit in the HSCR.

Type: Write-only

Word Size: 16-bit

Bit Map:

15	14	13	12	11	10	9	8
X	X	X	X	X	MOD3	MOD2	MOD1
7	6	5	4	3	2	1	0
MOD0	CNT6	CNT5	CNT4	CNT3	CNT2	CNT1	CNT0

Bit	Name	Description
15-11	X	Don't care bits – Unused.
10-7	MOD<3..0>	Module Number – The value of these bits plus one determines the number of the slot to be accessed for this scan entry. For example, to access Slot 6, MOD<3..0> would be 0101.
6-0	CNT<6..0>	Count – The value of these bits plus one determines how many samples are taken before the next scan list entry becomes active. A value of zero corresponds to one sample and a value of 127 corresponds to 128 samples.

Chapter 5

Programming

This chapter contains a functional programming description of the SCXI-1100 and Slot 0.

Note: If you plan to use a programming software package such as NI-DAQ, LabWindows, or LabVIEW with your SCXI-1100 board, you do not need to read this chapter.

Programming Considerations

Programming the SCXI-1100 involves writing to the Configuration Register. Programming Slot 0 involves writing to the HSCR and the FIFO Register. Programming the data acquisition boards involves writes to their registers. See your data acquisition board user manual for more information. The programming instructions list the sequence of steps to take. The instructions are language independent; that is, they instruct you to write a value to a given register without presenting the actual code.

Notation

For the bit patterns to be written, the following symbols are used:

- 0 Binary zero
- 1 Binary one
- X Don't care, either zero or one may be written
- G One of five bits used to specify the gain of the SCXI-1100. See the bit descriptions in the *Configuration Register* section in Chapter 4, *Register Descriptions*, for more information.
- C One of five bits used to specify the channel to be loaded into the MUXCOUNTER. This value is either the channel to be read for single reads, or a starting channel for scanned measurements.

The 24-bit patterns are presented MSB first, left to right.

Register Writes

This section describes how to write to the Configuration Register, the HSCR, and the FIFO Register, including the procedure for writing to the Slot-Select Register to select the appropriate slot. For timing specifics, refer to the *Communication Timing Requirements* section in Chapter 2, *Configuration and Installation*. Table 5-1 gives the rear signal connector pin equivalences to the different National Instruments data acquisition boards. Also see Appendix E, *SCXI-1100 Cabling*. The Configuration Register, the HSCR, and the FIFO Register are write-only registers.

The different bits in these registers often control independent pieces of circuitry. There are times when you may want to set or clear a specific bit or bits without affecting the remaining bits. However, a write to one of these registers affects all bits simultaneously. You cannot read the registers to determine which bits have been set or cleared in the past; therefore, maintain a software copy of these registers. You can then read the software copy to determine the status of the register. To change the state of a single bit without disturbing the remaining bits, set or clear the bit in the software copy and write the software copy to the register.

Table 5-1. SCXI-1100 Rear Signal Connector Pin Equivalences

SCXibus Line	SCXI-1100 Rear Signal Connector	MIO Boards	Lab Boards	PC-LPM-16
MOSI	SERDATIN	ADIO0	PB4	DOUT4
D*/A	DAQD*/A	ADIO1	PB5	DOUT5
INTR*	SLOT0SEL*	ADIO2	PB6	DOUT6
SPICLK	SERCLK	EXTSTROBE*	PB7	DOUT7
MISO	SERDATOUT	BDIO0	PC1	DIN6

Register Selection and Write Procedure

1. Select the slot of the module to be written to (or Slot 13 or 14). Initial conditions:

SERDATIN = X.
 DAQD*/A = X.
 SLOT0SEL* = 1.
 SERCLK = 1.

2. Clear SLOT0SEL* to 0 to deassert all SS* lines to all modules in all chassis.
3. For each bit, starting with the MSB (bit 15):
 - a. Set SERDATIN = bit to be sent. These bits are the data that is being written to the Slot-Select Register.
 - b. Clear SERCLK to 0.
 - c. Set SERCLK to 1. This rising edge clocks the data. (If you are using an MIO board, writing to the EXTSTROBE* register will pulse EXTSTROBE* low and then high, accomplishing steps 3b and 3c.)
4. Set SLOT0SEL* to 1. This asserts the SS* line of the module whose slot number was written to Slot 0. If you are using multiple chassis, only the appropriate slot in the chassis whose address corresponds to the written chassis number is automatically selected. When no communication is taking place between the data acquisition board and any modules, write zero to the Slot-Select Register to ensure that no accidental writes occur.
5. If you are writing to a Configuration Register, clear DAQD*/A to 0 (this indicates data is written to the Configuration Register). If you are writing to the HSCR or the FIFO Register, leave DAQD*/A high.
6. For each bit to be written to the Configuration Register:
 - a. Establish the desired SERDATIN level corresponding to this bit.
 - b. Clear SERCLK to 0.
 - c. Set SERCLK to 1 (clock the data). (If you are using an MIO board, writing to the EXTSTROBE* register pulses EXTSTROBE* low and then high, accomplishing steps 6b and 6c.)

7. Pull SLOTOSEL* low to deassert the SS* line, latch the data into the Configuration Register, and establish conditions for writing a new slot-select number to the Slot 0 Slot-Select Register.
8. If you are not selecting another slot, write zero to the Slot 0 Slot-Select Register. If you are selecting another slot, repeat this procedure starting at step 3.

For a timing illustration of a Configuration Register write, see Figure 2-12, *Configuration Register Write Timing Diagram*, which shows the proper write to configure an SCXI-1100 that is directly cabled to an MIO board for multiple-module multiplexed scanning with a start channel of 31 and an amplifier gain of 2,000.

Initialization

The SCXI-1100 powers up with its Configuration Register cleared to all zeros. You can force this state by pressing the Reset button on the front panel of Slot 0. In the reset state, the module outputs CH0 to MCH0± of the rear signal connector and can be clocked via SCANCLK to subsequent channels. The module is disconnected from Analog Bus 0. The total amplifier gain is 1.

Single-Channel Measurements

This section describes how to program the SCXI-1100, either alone or in conjunction with other modules, to make single-channel, or non-scanned, measurements.

Direct Measurements

To perform a direct measurement, you must cable the SCXI-1100 rear signal connector to a data acquisition board. See Chapter 2, *Configuration and Installation*, for more information. For information on how to make the voltage measurement with your data acquisition board, consult your data acquisition board user manual. Remember to account for the gains of both the SCXI-1100 and the data acquisition board when calculating the actual voltage present at the input of the SCXI-1100.

To measure one of the 32 differential input channels to the SCXI-1100, perform the following steps:

1. Write the binary pattern `XXXGGGGG 00XCCCCC 00001000` to the SCXI-1100 Configuration Register.
2. Measure the voltage with the data acquisition board.

To measure the voltage on the MTEMP line, perform the following steps:

1. Write the binary pattern `XXX00000 00XXXXXX 00101000` to the SCXI-1100 Configuration Register.
2. Measure the voltage with the data acquisition board.

To measure the output of the amplifier in the Calibration mode, perform the following steps:

1. Write the binary pattern `XXXGGGGG 00XXXXXX 1M001000` to the SCXI-1100 Configuration Register where:

`M = 0` if the amplifier inputs are to be grounded.

`M = 1` if the amplifier inputs are to be connected to Analog Bus 2.

2. Measure the voltage with the data acquisition board.

Indirect Measurements

Measurements from Other Modules

To perform measurements from other modules, you must cable the SCXI-1100 rear signal connector to a data acquisition board. See Chapter 2, *Configuration and Installation*, for more information. To make a measurement from another module, perform the following steps:

1. Perform any necessary programming to ensure that no modules are driving Analog Bus 0. For an SCXI-1100, clear `AB0EN` in the Configuration Register to ensure that its output is not driving `AB0`.
2. Write the binary pattern `XXX00000 00XXXXXX 00101011` to the SCXI-1100 Configuration Register. This step disables the SCXI-1100 from driving Analog Bus 0 and allows Analog Bus 0 to drive `MCH0` through the output buffer.
3. Program the other module to drive Analog Bus 0 with the signal to be measured.
4. Measure the voltage with the data acquisition board.

Measurements from the SCXI-1100 via Another Module

To perform measurements via another module, you must cable the other module rear signal connector to a data acquisition board. The other module must be able to transfer Analog Bus 0 to the data acquisition board. See Chapter 2, *Configuration and Installation*, for more information.

To measure one of the 32 differential input channels of the SCXI-1100, perform the following steps:

1. Perform any necessary programming to ensure that no modules are driving Analog Bus 0. For an SCXI-1100, clear `AB0EN` in the Configuration Register to ensure that its output is not driving `AB0`.
2. Program the other module not to drive Analog Bus 0, but to send Analog Bus 0 to the data acquisition board.
3. Write the binary pattern `XXXGGGGG 00XCCCCC 00001010` to the SCXI-1100 Configuration Register.
4. Measure the voltage with the data acquisition board.

To measure the voltage on the MTEMP line, perform the following steps:

1. Perform any necessary programming to ensure that no modules are driving Analog Bus 0. For an SCXI-1100, clear AB0EN in the Configuration Register to ensure that its output is not driving AB0.
2. Program the other module not to drive Analog Bus 0, but to send Analog Bus 0 to the data acquisition board.
3. Write the binary pattern `XXX00000 00XXXXXX 00101010` to the SCXI-1100 Configuration Register.
4. Measure the voltage with the data acquisition board.

To measure the output of the amplifier in the Calibration mode, perform the following steps:

1. Perform any necessary programming to ensure that no modules are driving Analog Bus 0. For an SCXI-1100, clear AB0EN and/or set FOUTEN* in the Configuration Register.
2. Program the other module not to drive Analog Bus 0, but to send Analog Bus 0 to the data acquisition board.
3. Write the binary pattern `XXXGGGGG 00XXXXXX 1M001010` to the SCXI-1100 Configuration Register where:

M = 0 if the amplifier inputs are to be grounded.

M = 1 if the amplifier inputs are to be connected to Analog Bus 2.

4. Measure the voltage with the data acquisition board.

Scanning Measurements

Programming for scanned data acquisition involves programming your data acquisition board, modules, and Slot 0. In general, the steps to be taken are as follows:

1. Perform all data acquisition board programming to the point of enabling the data acquisition.
2. Perform all module programming.
3. Program the Slot 0 hardscan circuitry.
4. Enable the data acquisition, trigger it either through software or hardware, and service the data acquisition.

You can only channel scan with MIO boards. The Lab boards and the PC-LPM-16 board do not support channel scanning.

1. Data Acquisition Board Setup Programming

The programming steps for your data acquisition board are given in your data acquisition board user manual. You should follow the instructions in the following sections:

- *AT-MIO-16 User Manual*
 - *Multiple A/D Conversions with Continuous Channel Scanning (Round Robin)*
 - *Multiple A/D Conversions with Interval Channel Scanning (Pseudo-Simultaneous)*
- *AT-MIO-16D User Manual*
 - *Multiple A/D Conversions with Continuous Channel Scanning (Round Robin)*
 - *Multiple A/D Conversions with Interval Channel Scanning (Pseudo-Simultaneous)*
- *AT-MIO-16F-5 User Manual*
 - *Posttrigger Data Acquisition with Continuous Channel Scanning*
 - *Posttrigger Data Acquisition with Interval Channel Scanning*
- *AT-MIO-16X User Manual*
 - *Continuous Channel Scanning Data Acquisition*
 - *Interval Channel Scanning Data Acquisition*
- *AT-MIO-64F-5 User Manual*
 - *Continuous Channel-Scanning Data Acquisition*
 - *Interval Channel-Scanning Data Acquisition*
- *MC-MIO-16 User Manual*
 - *Multiple A/D Conversions with Continuous Channel Scanning (Round Robin)*
 - *Multiple A/D Conversions with Interval Channel Scanning (Pseudo-Simultaneous)*
- *NB-MIO-16X User Manual*
 - *Multiple A/D Conversions with Continuous Channel Scanning (Round Robin)*
 - *Multiple A/D Conversions with Interval Channel Scanning (Pseudo-Simultaneous)*
- *NB-MIO-16 User Manual*
 - *Programming Multiple A/D Conversions with Channel Scanning*

Follow the instructions in these sections through the part labeled as follows:

- *Clear the A/D circuitry and reset the mux counter* in the MIO board user manual (except for the AT-MIO-16X and AT-MIO-64F-5). Do not continue to the part called *Enable the scanning data acquisition operation* until you program the modules and Slot 0.
- *Program the sample counter* (if you are doing continuous channel scanning) or *Program the scan-interval counter* (if you are doing interval channel scanning) in the AT-MIO-16X and AT-MIO-64F-5 user manuals. Do not continue to the part labeled *Enable a scanning data acquisition operation* or *Enable an interval scanning data acquisition operation* until you program the modules and Slot 0.

Note: For multiplexed scanning with an MIO board, it is important that you follow the instructions in the channel scanning sections, not the single-channel sections. Although you may be using only one MIO board channel, the channel scanning programming ensures that the MIO board outputs SCANCLK, which the SCXI-1100 and Slot 0 need.

Counter 1 and SCANDIV

All MIO boards can operate their data acquisition board scan lists in two ways—they can acquire one sample per data acquisition board scan list entry; or they can acquire N samples per data acquisition board scan list entry, where N is a number from 2 to 65,535 that is programmed in Counter 1. This second method of operation is especially useful when the data acquisition board scan list length is limited to 16 entries, as it is on all MIO boards except the AT-MIO-16F-5, AT-MIO-16X, and AT-MIO-64F-5, which can have up to 512 entries. Because you can multiplex many SCXI-1100s in one chassis to one MIO board channel, often the simplest way to program the MIO board is to use only one data acquisition board scan list entry, and make N the total number of samples to be taken on all modules in one scan. Check your MIO board user manual for limitations in the data acquisition board scan list format.

Because the SCXI-1100 has a fixed programmable gain, you may want to split up the samples across data acquisition board scan list entries in order to use different gains of the MIO board. For example, with the AT-MIO-16F-5, each sample can have its own gain entry. With the other MIO boards, you can still group similar signals together and have, for example, the first five readings at one MIO channel gain, the next five readings at another MIO gain, and so on. Notice, however, that it is best to apply gain to a signal on the SCXI-1100 rather than to amplify it later on the MIO board. Applying gain on the SCXI-1100 results in the SCXI chassis sending a high-level signal, which is less susceptible to noise than a low-level signal, to the MIO board. If you have different signals with greatly differing ranges, the best solution for reducing noise is to use multiple SCXI-1100s with each module programmed for a gain best suited for the signals the module is receiving.

To program the MIO board to take N samples per data acquisition board scan list entry, perform the following additional programming steps at the end of the *Enable the Scanning Data Acquisition Operation*, *Enable a Scanning Data Acquisition Operation*, or *Enable an Interval Scanning Data Acquisition Operation* section in the appropriate data acquisition board user manual:

1. Write FF01 to the Am9513 Command Register to select Counter 1 Mode Register.
2. Write 0325 (hex) to the Am9513 Data Register to store Counter 1 Mode Value for most MIO boards. For the AT-MIO-16F-5, the AT-MIO-16X, and the AT-MIO-64F-5, write 1325 (hex).

3. Write FF09 to the Am9513 Command Register to select Counter 1 Load Register.
4. Write the number of samples to be taken per scan list entry (2 to 65,535) to the Am9513 Data Register to load Counter 1.
5. Write FF41 to the Am9513 Command Register to load Counter 1.
6. Write FFF1 to the Am9513 Command Register to step Counter 1.
7. Write FF21 to the Am9513 Command Register to arm Counter 1.
8. Set the SCANDIV bit in Command Register 1.

2. Module Programming

This section describes the programming steps for various scanning possibilities.

Single-Module Multiplexed Scanning (Direct)

To perform simple channel scanning, cable the SCXI-1100 to a data acquisition board. See Chapter 2, *Configuration and Installation*, for more information.

To program the module for scanned-channel measurements, write the binary pattern XXXGGGGG 10XCCCCC 00000101 to the SCXI-1100 Configuration Register. CCCCC represents the starting channel number.

Single-Module Multiplexed Scanning (Indirect)

Channel Scanning from Other Modules. To scan measurements from other modules, cable the SCXI-1100 to a data acquisition board. See Chapter 2, *Configuration and Installation*, for more information. The module programming steps are as follows:

1. Perform any necessary programming to ensure that no modules are driving Analog Bus 0. For an SCXI-1100, clearing ABOEN in the Configuration Register ensures that the SCXI-1100 output is not driving AB0.
2. Write the binary pattern XXX00000 10XXXXXX 00101011 to the SCXI-1100 Configuration Register. This step disables the SCXI-1100 from driving Analog Bus 0 and allows Analog Bus 0 to drive MCH0 through the output buffer.
3. Program the other module to be scanned.

Channel Scanning from the SCXI-1100 via Another Module. To scan the SCXI-1100 via other modules, cable the other module to a data acquisition board; the other module must be able to transfer Analog Bus 0 to the data acquisition board. The other module must also be able to

send a SCANCLK*-compatible signal on TRIG0. See Chapter 2, *Configuration and Installation*, for more information. The module programming steps are as follows:

1. Perform any necessary programming to ensure that no modules are driving Analog Bus 0. For an SCXI-1100, clearing ABOEN in the Configuration Register ensures that the register output is not driving ABO.
2. Program the other module not to drive Analog Bus 0, but to send Analog Bus 0 to the data acquisition board. Also program the other module to send a SCANCLK*-compatible signal onto TRIG0.
3. Write the binary pattern `XXXGGGGG 01XCCCCC 00000111` to the SCXI-1100 Configuration Register, where CCCCC is the starting channel number.

Multiple-Module Multiplexed Scanning

To scan multiple modules, connect one module to the data acquisition board; the module must be able to transfer Analog Bus 0 to the data acquisition board. This module must also be capable of sending a SCANCLK*-compatible signal on TRIG0. See Chapter 2, *Configuration and Installation*, for more information. The module programming steps are as follows:

1. Perform any necessary programming to ensure that no modules are driving Analog Bus 0. For an SCXI-1100, clearing ABOEN in the Configuration Register will ensure that its output is not driving ABO.
2. Program the module that is connected to the data acquisition board to connect Analog Bus 0 to the data acquisition board but not drive Analog Bus 0 unless it is receiving an active low signal on SCANCON. Also program the other module to send a SCANCLK*-compatible signal onto TRIG0. If this module is an SCXI-1100, write the binary pattern `XXXGGGGG 10XCCCCC 00000111` to its Configuration Register.

Note: If this module is an SCXI-1100 and is not going to be scanned (it is being used only as an interface), write a 0 to bit 2 (SCANCONEN) in the Configuration Register. The gains and start channel become don't care bits.

3. Program the other modules to be used in the scan to connect their outputs to Analog Bus 0 but not drive Analog Bus 0 unless they are receiving an active low signal on SCANCON. Also program the modules to use TRIG0 as their clock source. For SCXI-1100 modules, write the binary pattern `XXXGGGGG 01XCCCCC 00000111` to their Configuration Registers.

Multiple-Chassis Scanning

To scan modules on multiple chassis, you must use the SCXI-1001 chassis. The cable from the data acquisition board must bus the digital lines to one module on each chassis. Additionally, the cable must provide each chassis with its own analog channel. The data acquisition board must be able to take several readings at a time on a given channel before accessing a new channel. See the *Counter 1 and SCANDIV* subsection of the *1. Data Acquisition Board Setup Programming* section earlier in this chapter. You can use the MIO boards, along with the SCXI-1350 multichassis adapter, for multiple-chassis scanning.

For each chassis, program the modules according to the appropriate mode of operation, disregarding the fact that other chassis are involved.

For example, you want to scan 13 modules. Twelve modules are in one chassis, and the 13th is in the second chassis and is to be scanned through a 14th module that is cabled to the data acquisition board but is not involved in the scan. Program the 12 modules in the first chassis according to the steps listed in the previous *Multiple-Module Multiplexed Scanning* section, and program the 13th and 14th modules according to the *Channel Scanning from the SCXI-1100 via Another Module* section earlier in this chapter.

3. Programming the Slot 0 Hardscan Circuitry

The following section describes how to program the Slot 0 circuitry for scanning operations. For a more detailed description of the Slot 0 scanning circuitry, consult the *SCXI-1000/1001 User Manual*. Descriptions of the Slot 0 registers are given in the *Slot 0 Register Descriptions* section in Chapter 4, *Register Descriptions*.

To program the hardscan circuitry, perform the following steps:

1. Write binary 0000 0000 to the HSCR.
2. Write binary 0000 1000 to the HSCR.
3. Write the Slot 0 scan list to the FIFO.
4. Write binary 0010 1100 to the HSCR.
5. Write binary 101S 1100 to the HSCR.
6. Write binary 101S 1110 to the HSCR.
7. Write binary 101S 1111 to the HSCR.

To program the hardscan circuitry to use the current scan list, perform the following steps:

1. Write binary 0000 1000 to the HSCR.
2. Write binary 0100 1000 to the HSCR.
3. Write binary 0000 1000 to the HSCR.
4. Write binary 0010 1100 to the HSCR.
5. Write binary 101S 1100 to the HSCR.
6. Write binary 101S 1110 to the HSCR.
7. Write binary 101S 1111 to the HSCR,

In the preceding steps:

S = 0 if you want the scanning to repeat when the end of the list is reached.

S = 1 if you want the circuitry to shut down after a single scan.

When you are writing multiple entries to the same register—for example, repetitive writes to the HSCR or several FIFO entries—it is important that SS*13 or SS*14 go inactive (high) between each entry. Select another slot or toggle the SLOTOSEL* line to temporarily deassert the appropriate SS* line.

If consecutive scan list entries access an SCXI-1100, the module reloads the MUXCOUNTER with the starting channel after each entry. Thus, two entries for one module with counts of four yield different behavior than one entry with a count of eight.

For multiple-chassis scanning, program each Slot 0 to have dummy entries to fill the sample counts when the data acquisition board is accessing other chassis. Use Slot 13 as the dummy entry slot.

See *Example 3* at the end of this chapter.

4. Acquisition Enable, Triggering, and Servicing

At this point, you should now continue from where you left off in the *1. Data Acquisition Board Setup Programming* section of this chapter. Perform the following steps given in your data acquisition board user manual:

1. Enable the scanning data acquisition operation.
2. Apply a trigger.
3. Service the data acquisition operation.

Scanning Examples

The following examples are intended to aid your understanding of module and Slot 0 programming. You may want to refer to the bit descriptions for the Configuration Register and the FIFO Register in Chapter 4, *Register Descriptions*.

Example 1

You want to scan channels 3 through 9 at a gain of 1 on an SCXI-1100 in Slot 1 of an SCXI-1000 chassis. The SCXI-1100 is directly cabled to a data acquisition board.

The programming steps are as follows:

1. Program your data acquisition board as described in the *1. Data Acquisition Board Setup Programming* section of this chapter.
2. Performing the procedure given in the *Register Writes* section earlier in this chapter, write 00000000 10000011 00000101 to the Configuration Register of the SCXI-1100 in Slot 1.

3. Perform the steps outlined in the *3. Programming the Slot 0 Hardscan Circuitry* section earlier in this chapter, where step 3, *Write the Slot 0 scan list to the FIFO*, consists of the following:

Write 00000000 00000110 to the FIFO Register. This corresponds to Slot 1 for seven samples.

4. Perform the procedure given in the *4. Acquisition Enable, Triggering, and Servicing* section earlier in this chapter.

Example 2

An SCXI-1000 chassis has SCXI-1100 modules in Slots 1, 2, 3, and 4. The SCXI-1100 in Slot 4 is cabled to the data acquisition board. You want to scan channels 17 through 25 on the SCXI-1100 in Slot 1 at a gain of 1, channels 0 through 29 on the SCXI-1100 in Slot 4 at a gain of 50, and channels 28 through 7 on the SCXI-1100 in Slot 3 at a gain of 2,000.

The programming steps are as follows:

1. Program your data acquisition board as described in the *1. Data Acquisition Board Setup Programming* section earlier in this chapter.
2. Performing the procedure given in the *Register Writes* section earlier in this chapter, write 00000000 00000000 00000000 to the Configuration Register of the SCXI-1100 in Slot 2. This step resets the module, including the clearing of the ABOEN bit (bit 0). Notice that a complete reset of this module is not necessary, but is used for simplicity.
3. Performing the procedure given in the *Register Writes* section earlier in this chapter, write xxx01001 10x00000 00000111 to the Configuration Register of the SCXI-1100 in Slot 4.
4. Performing the procedure given in the *Register Writes* section earlier in this chapter, write xxx00000 01x10001 00000111 to the Configuration Register of the SCXI-1100 in Slot 1.
5. Performing the procedure given in the *Register Writes* section earlier in this chapter, write xxx10010 01x11100 00000111 to the Configuration Register of the SCXI-1100 in Slot 3. Notice that after Channel 31, the SCXI-1100 will wrap around to Channel 0.
6. Perform the steps given in the *3. Programming the Slot 0 Hardscan Circuitry* section earlier in this chapter, where step 3, *Write the Slot 0 scan list to the FIFO*, consists of:
 - a. Write 00000000 00001000 to the FIFO Register. This corresponds to Slot 1 for nine samples.
 - b. Write 00000001 10011101 to the FIFO Register. This corresponds to Slot 4 for 30 samples.
 - c. Write 00000001 00001011 to the FIFO Register. This corresponds to Slot 3 for 12 samples.

Make sure to toggle SLOT0SEL* or reselect the FIFO Register from scratch between steps 6a, 6b, and 6c.
7. Perform the procedure given in the *4. Acquisition Enable, Triggering, and Servicing* section earlier in this chapter.

Example 3

In this example, you want to scan 31 channels on an SCXI-1100 in Slot 4 of Chassis 1, then seven channels of an SCXI-1100 in Slot 11 of Chassis 2, three channels of an SCXI-1100 in Slot 3 of Chassis 3, and 25 channels of an SCXI-1100 in Slot 8 of Chassis 3. Assuming that the modules are cabled and programmed correctly, the Slot 0 scan lists should be as follows:

Chassis 1			Chassis 2			Chassis 3		
Entry	Slot Number	Count	Entry	Slot Number	Count	Entry	Slot Number	Count
1	4	31	1	13	31	1	13	38
2	13	35	2	11	7	2	3	3
			3	13	28	3	8	25

Other solutions are possible.

Perform the steps outlined in the 3. *Programming the Slot 0 Hardscan Circuitry* section earlier in this chapter, where step 3, *Write the Slot 0 scan list to the FIFO*, consists of the following steps:

1. Select Slot 13 in Chassis 1.
2. Write `XXXXX001 10011110` over MOSI.
3. Toggle SLOT0SEL*.
4. Write `XXXXX110 00100010` over MOSI.
5. Select Slot 13 in Chassis 2.
6. Write `XXXXX110 00011110` over MOSI.
7. Toggle SLOT0SEL*.
8. Write `XXXXX101 00000110` over MOSI.
9. Toggle SLOT0SEL*.
10. Write `XXXXX110 00011100` over MOSI.
11. Select Slot 13 in Chassis 3.
12. Write `XXXXX110 00100110` over MOSI.
13. Toggle SLOT0SEL*.
14. Write `XXXXX001 00000010` over MOSI.

15. Toggle SLOT0SEL*.
16. Write `XXXXX011 10011001` over MOSI.
17. Select Slot 0 in Chassis 0.

Appendix A

Specifications

This appendix lists the specifications for the SCXI-1100. These are typical at 25° C unless otherwise stated. The operating temperature range is 0° to 50° C.

Analog Input

Number of channels	32 differential
Analog input range ¹	±10 V
Instrumentation amplifier	
Input bias current	±350 pA
Input offset current	±350 pA
Gain (software-selectable)	1, 2, 5, 10, 20, 50, 100, 200, 500, 1,000, 2,000
Input impedance	>1 GΩ
Settling time (with 10 V step)	
Full bandwidth	

Accuracy	Gain				
	1-100	200	500	1,000	2,000
0.012% ²	6 μs 7 μs maximum	7.5 μs	12 μs	20 μs	25 μs
0.006% ³	10 μs	10 μs	25 μs	26 μs	30 μs
0.0015% ³	32 μs	33 μs	40 μs	76 μs	195 μs

With filtering (all gains)

Accuracy	Bandwidth	
	10 kHz	4 Hz
0.012% ²	150 μs	0.35 s
0.006% ³	160 μs	0.4 s
0.0015% ³	200 μs	0.5 s

¹Includes both common-mode voltage and differential voltage

²Combined settling time of the SCXI-1100 and the AT-MIO-16F-5

³Combined settling time of the SCXI-1100 and the AT-MIO-16X

Filters	4 Hz, 10 kHz, full bandwidth (jumper selectable)
Filter type	Single-pole RC
Overload recovery time	11 μ s at gain = 100
Noise (gain = 1,000; 400 kHz BW)	
4 Hz filter	0.2 μ Vrms RTI
10 kHz filter	1.5 μ Vrms RTI
No filter	6 μ Vrms RTI
Gain error at DC	
Gain = 1	0.01% maximum
All other gains	0.1%
Gain temperature coefficient	20 ppm/ $^{\circ}$ C
Common-mode rejection ratio	DC to 60 Hz
10 kHz and full bandwidth	
Gain = 1 to 5	78 dB minimum
Gain = 10 to 2,000	90 dB minimum
4 Hz bandwidth	
Gain = 1 to 5	98 dB minimum
Gain = 10 to 2,000	110 dB minimum
Offset voltage	
Output uncalibrated	1 mV typical 3 mV maximum
Output calibrated	40 μ V
Input uncalibrated	70 μ V typical 1 mV maximum
Input calibrated	5 μ V
Offset voltage drift	
Input	4 μ V/ $^{\circ}$ C
Output	20 μ V/ $^{\circ}$ C
Input protection	
Power on	\pm 25 V
Power off	\pm 15 V
Cross talk (channel-to-channel, 50 Ω source and 50 Ω termination)	
4 Hz	-120 dB
10 kHz	-65 dB
Power dissipation	4.5 W

Explanation of Analog Input Specifications

Analog input range is the common and differential mode voltages that can be applied on the PGIA inputs without resulting in excessive distortion at the output.

Settling time is the time it takes the PGIA to settle within an error band when its output is responding to a 10 V step change.

Physical

Dimensions	1.2 by 6.8 by 8.0 in.
Connectors	50-pin male ribbon-cable rear connector 96-pin DIN C front connector (70-screw terminal adapter available)

Cold-Junction Sensor⁴

Accuracy	0.9° C over 0° to 55° C
Output	10 mV/°C

Operating Environment

Temperature	0° to 50° C
Relative humidity	5% to 90% at 35° C

Storage Environment

Temperature	-55° to 150° C
Relative humidity	5% to 90% noncondensing

⁴Located on the SCXI-1300 terminal block

Appendix B

Rear Signal Connector

This appendix describes the pinout and signal names for the SCXI-1100 50-pin rear signal connector, including a description of each connection.

Figure B-1 shows the pin assignments for the SCXI-1100 rear signal connector.

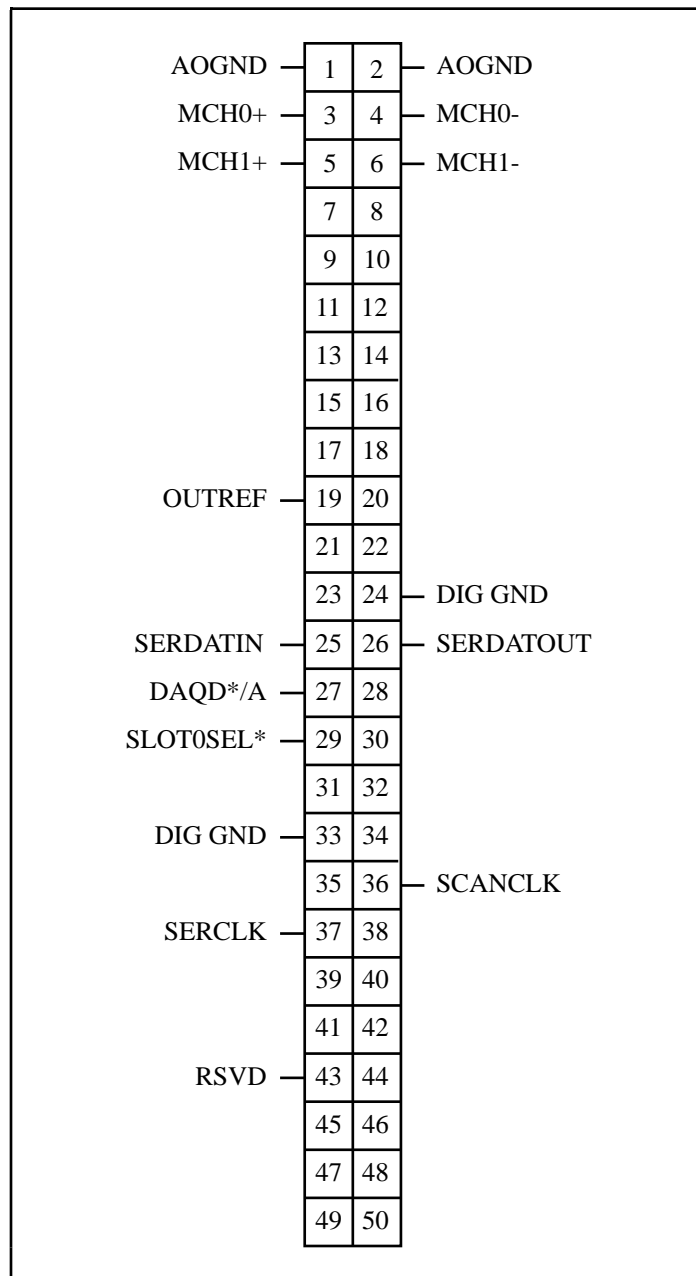

Figure B-1. SCXI-1100 Rear Signal Connector Pin Assignment

Rear Signal Connector Signal Descriptions

Pin	Signal Name	Description
1-2	AOGND	Analog Output Ground – Connected to the PGIA reference when jumper W10 is in position AB-R0.
3-6	MCH0± and MCH1±	Analog Output Channels 0 and 1 – Connects to the data acquisition differential analog input channels.
19	OUTREF	Output Reference – Serves as the reference node for the PGIA output in the Pseudodifferential Output mode. You should connect OUTREF to the analog input sense of the NRSE data acquisition board.
24, 33	DIG GND	Digital Ground – Supply the reference for data acquisition digital signals and are tied to the module digital ground.
25	SERDATIN	Serial Data In – Taps into the SCXIBus MOSI line to provide serial input data to a module or Slot 0.
26	SERDATOUT	Serial Data Out – Taps into the SCXIBus MISO line to accept serial output data from a module.
27	DAQD*/A	Data Acquisition Board Data/Address Line – Taps into the SCXIBus D*/A line to indicate to the module whether the incoming serial stream is data or address information.
29	SLOT0SEL*	Slot 0 Select – Taps into the SCXIBus INTR* line to indicate whether the information on MOSI is being sent to a module or Slot 0.
36	SCANCLK	Scan Clock – Indicates to the SCXI-1100 that the data acquisition board has taken a sample; also causes the SCXI-1100 to change channels.
37	SERCLK	Serial Clock – Taps into the SCXIBus SPICLK line to clock the data on the MOSI and MISO lines.
43	RSVD	Reserved.

* Indicates active low.

All other pins are not connected.

See the *Timing Requirements and Communication Protocol* section in Chapter 2, *Configuration and Installation*, for more detailed information on timing. Detailed signal specifications are also included in Chapter 2.

Appendix C

SCXibus Connector

This appendix describes the pinout and signal names for the SCXI-1100 96-pin SCXibus connector, including a description of each connection.

Figure C-1 shows pinout of the SCXI-1100 SCXibus connector.

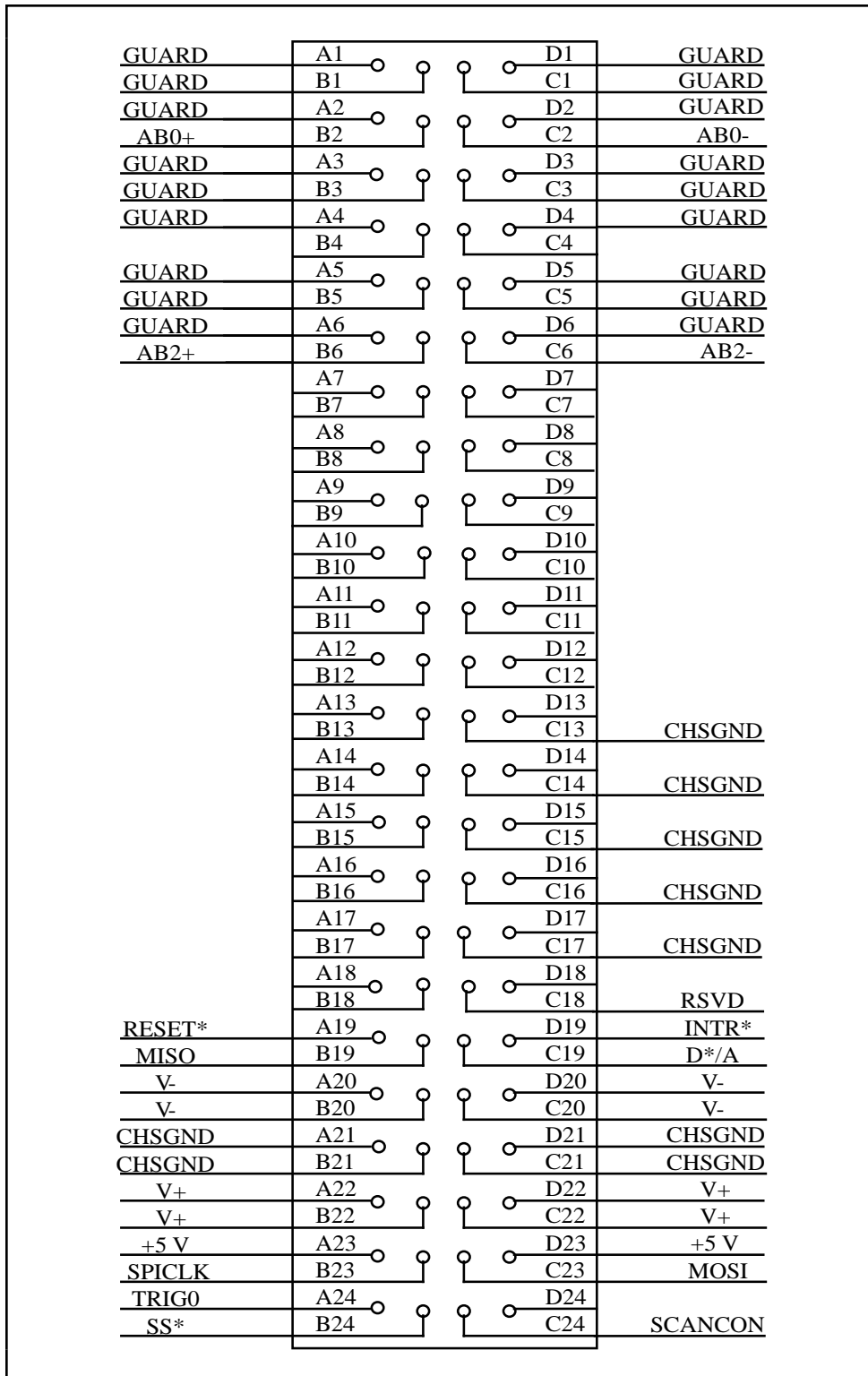

Figure C-1. SCXIBus Connector Pin Assignment

SCXIbus Connector Signal Descriptions

Pin	Signal Name	Description
A1, B1, C1, D1, A2, D2, A3, B3, C3, D3, A4, D4, A5, B5, C5, D5, A6, D6	GUARD	Guard – Shield and guard the analog bus lines from noise.
B2	AB0+	Analog Bus 0+ – Positive analog bus 0 line. Used to multiplex several modules to one analog signal.
C2	AB0-	Analog Bus 0- – Negative analog bus 0 line. Used to multiplex several modules to one analog signal.
B6	AB2+	Analog Bus 2+ – Positive analog bus 2 line. Refer to the <i>Calibration</i> section later in this chapter for information on the use of this pin.
C6	AB2-	Analog Bus 2- – Negative analog bus 2 line. Refer to the <i>Calibration</i> section later in this chapter for information on the use of this pin.
C13-C17, A21, B21, C21, D21	CHSGND	Chassis Ground – Digital and analog ground reference.
C18	RSVD	Reserved.
A19	RESET*	Reset – When pulled low, reinitializes the module to its power-up state. Totem pole. Input.
B19	MISO	Master-In-Slave-Out – Transmits data from the module to the SCXIbus. Open collector. I/O.
C19	D*/A	Data/Address – Indicates to the module whether address information or data information is being sent to the module on MOSI. Open collector. I/O.
D19	INTR*	Interrupt – Active low. Causes data that is on MOSI to be written to the Slot-Select Register in Slot 0. Open collector. Output.
A20, B20, C20, D20	V-	Negative Analog Supply – -18.5 V to -25 V.
A22, B22, C22, D22	V+	Positive Analog Supply – +18.5 V to +25 V.
A23, D23	+5 V	+5 VDC Source – Digital power supply.

Pin	Signal Name	Description (continued)
B23	SPICLK	Serial Peripheral Interface (SPI) Clock – Clocks the serial data on the MOSI and MISO lines. Open collector. I/O.
C23	MOSI	Master-Out-Slave-In – Transmits data from the SCXIBus to the module. Open collector. I/O.
A24	TRIG0	TRIG0 – General-purpose trigger line that the SCXI-1100 uses to send SCANCLK to other modules or receive SCANCLK from other modules. Open collector. I/O.
B24	SS*	Slot Select – When low, enables module communications over the SCXIBus. Totem pole. Input.
C24	SCANCON	Scanning Control – Combination output enable and reload signal for scanning operations. Totem pole. Input.

* Indicates active low

All other pins are not connected.

Further information is given in Chapter 3, *Theory of Operation*.

Front Connector Signal Descriptions

Pin	Signal Name	Description
A1	+5 V	+5 VDC Source – Used to power the temperature sensor on the terminal block. 0.2 mA of source not protected.
A2, A5, A16, A24, A32	CGND	Chassis Ground – Tied to the SCXI chassis.
A3	MTEMP	Multiplexed Temperature Sensor – Connects the temperature sensor to the output multiplexer.
A4	DTEMP	Direct Temperature Sensor – Connects the temperature sensor to the MCH1+ signal when the terminal block is configured for direct temperature connection.
A6	GUARD	Guard – Connected to the SCXIbus guard.
A7	AOREF	Analog Output Reference – Connected to the MCH0- signal as described in the <i>Analog Configuration</i> section.
A8	OUTPUT	Output – Connected to the MCH0+ signal as described in the <i>Analog Configuration</i> section.
B1-B32	CH31- through CH0-	Negative Input Channels – Negative input channels to the PGIA.
C1-C32	CH31+ through CH0+	Positive Input Channels – Positive input channels to the PGIA.

Further information is given in Chapter 2, *Configuration and Installation*.

Appendix E

SCXI-1100 Cabling

This appendix describes how to use and install the hardware accessories for the SCXI-1100:

- SCXI-1340 cable assembly
- SCXI-1341 Lab-NB/Lab-PC/Lab-PC+ cable assembly
- SCXI-1342 PC-LPM-16 cable assembly
- SCXI-1344 Lab-LC cable assembly
- SCXI-1180 feedthrough panel
- SCXI-1302 50-pin terminal block
- SCXI-1351 one-slot cable extender
- SCXI-1350 multichassis adapter
- SCXI-1343 screw terminal adapter

SCXI-1340 Cable Assembly

The SCXI-1340 cable assembly connects any MIO board (except the AT-MIO-16D and the AT-MIO-64F-5) to an SCXI-1100 module. The SCXI-1340 consists of a 50-conductor ribbon cable that has a mounting bracket at one end and a 50-pin female connector at the other end. This female connector attaches to the MIO board I/O connector. Attached to the mounting bracket is a 50-pin female mounting bracket connector that connects to the module rear signal connector. A male breakout connector is near the mounting bracket on the ribbon cable. You can use this male breakout connector to extend the signals of the MIO board to an SCXI-1180 feedthrough panel or an SCXI-1181 breadboard module. All 50 pins from the MIO board go straight to the rear signal connector. You can use a standard 50-pin ribbon cable in lieu of the SCXI-1340 cable assembly.

The SCXI-1340 has the following advantages over the ribbon cable:

- The SCXI-1340 produces strain relief so that you cannot accidentally disconnect the cable.
- The SCXI-1340 includes a mounting bracket that mounts to the chassis so that you can remove and reinsert the module without explicitly removing the cable from the back of the chassis. This is especially useful when the SCXI chassis is rack mounted, making rear access difficult.

- The SCXI-1340 has an extra male breakout connector for use with the SCXI-1180 feedthrough panel or additional modules or breadboards that need a direct connection to the MIO board.
- The SCXI-1340 rear panel gives both mechanical and electrical shielding.

Table E-1 lists the pin equivalences of the MIO board and the SCXI-1100.

Table E-1. SCXI-1100 and MIO Board Pinout Equivalences

Pin	SCXI-1100 Rear Signal Connector	MIO Board Equivalent
1-2	AOGND	AIGND
3	MCH0+	ACH0
4	MCH0-	ACH8
5	MCH1+	ACH1
6	MCH1-	ACH9
19	OUTREF	AISENSE
24, 33	DIG GND	DIG GND
25	SERDATIN	ADIO0
26	SERDATOUT	BDIO0
27	DAQD*/A	ADIO1
29	SLOT0SEL*	ADIO2
36	SCANCLK	SCANCLK
37	SERCLK	EXTSTROBE*
43	RSVD	OUT1

No other pins are connected on the SCXI-1100.

SCXI-1340 Installation

Perform the following steps to install the SCXI-1340:

1. Make sure that the computer and the SCXI chassis are turned off.
2. Install the SCXI module in the chassis.
3. Plug the mounting bracket connector onto the module rear signal connector (see Figure E-1). Make sure the alignment tab on the bracket enters the upper board guide of the chassis.
4. Screw the mounting bracket to the threaded strips in the rear of the chassis.
5. Connect the loose end of the cable assembly to the MIO board I/O connector.

Check the installation.

After step 1, the order of these steps is not critical; however, it is easier to locate the correct position for the mounting bracket with a module installed in the chassis. If you are attaching a cable to the breakout connector, installation is easiest if you attach the second cable before installing the SCXI-1340.

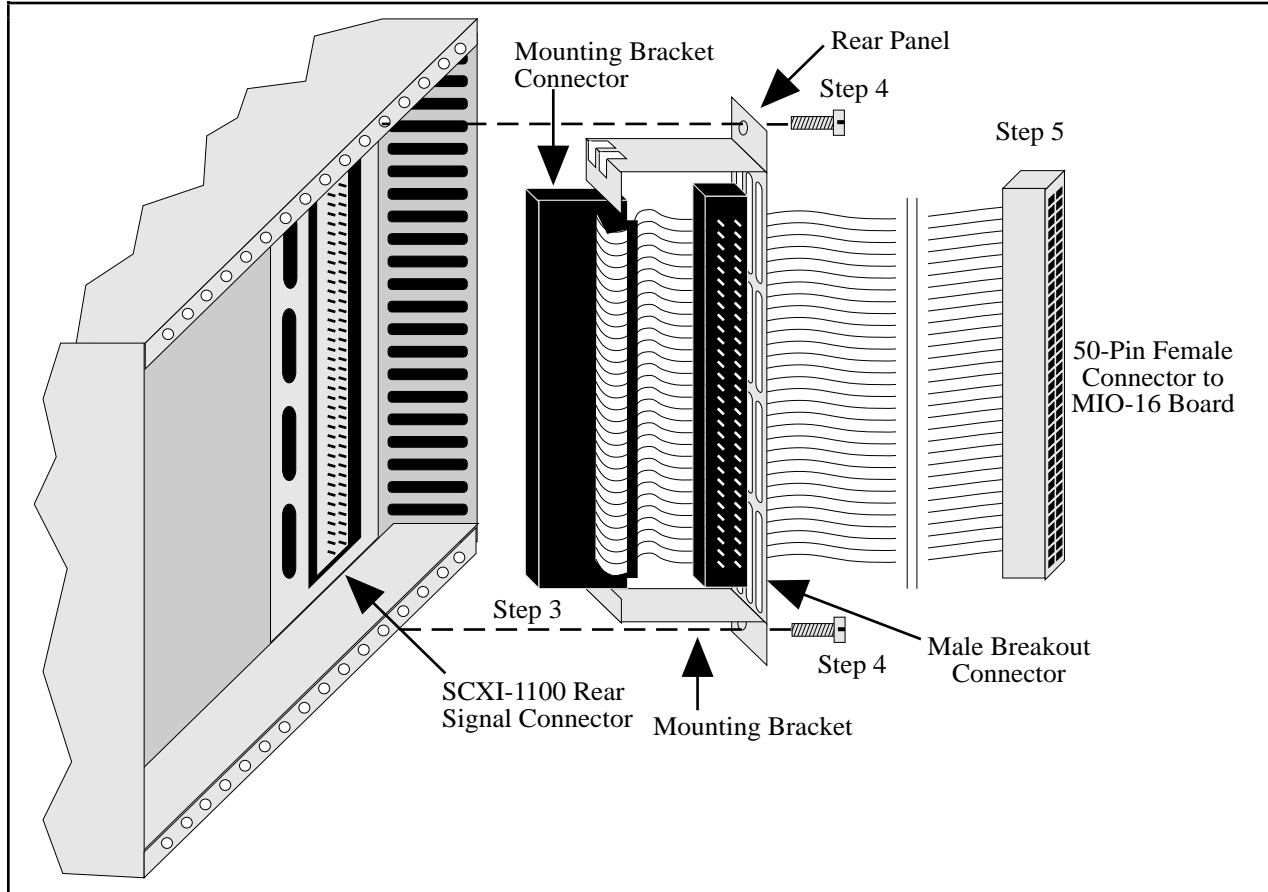

Figure E-1. SCXI-1340 Installation

SCXI-1341 Lab-NB, Lab-PC, or Lab-PC+ and SCXI-1344 Lab-LC Cable Assemblies

The SCXI-1341 Lab-NB, Lab-PC, or Lab-PC+ cable assembly connects a Lab-NB, Lab-PC, or Lab-PC+ board to an SCXI-1100 module. The SCXI-1344 Lab-LC cable assembly connects a Lab-LC board to an SCXI-1100 module. The SCXI-1341 and SCXI-1344 cable assemblies consist of two pieces—an adapter board and a 50-conductor ribbon cable that connects the Lab board to the rear connector of the adapter board. The adapter board converts the signals from the Lab board I/O connectors to a format compatible with the SCXI-1100 rear signal connector pinout at the front connector of the SCXI-1341 or SCXI-1344. The adapter board also has an additional male breakout connector that provides the unmodified Lab board signals for use with an SCXI-1180 feedthrough panel or an SCXI-1181 breadboard module. The adapter board gives the Lab boards full access to the digital control lines, but these boards take only single measurements and cannot scan channels. Leave jumper W1 in position A on the SCXI-1341 and SCXI-1344. The SCXI-1100 does not use jumper W1. Table E-2 lists the SCXI-1341 and SCXI-1344 pin translations.

Note: If you are using the Lab-PC+, configure the board for single-ended inputs.

Table E-2. SCXI-1341 and SCXI-1344 Pin Translations

Lab Board Pin	Lab Board Signal	SCXI-1100 Pin	SCXI-1100 Signal
1	ACH0	3	MCH0+
2	ACH1	5	MCH1+
3	ACH2	7	No Connect
4	ACH3	9	No Connect
5	ACH4	11	No Connect
6	ACH5	13	No Connect
7	ACH6	15	No Connect
8	ACH7	17	No Connect
9	AIGND	1-2	AOGND
10	DAC0OUT	20	No Connect
11	AOGND	23	No Connect
12	DAC1OUT	21	No Connect
13, 50	DGND	24, 33	DIG GND
26	PB4	25	SERDATIN
27	PB5	27	DAQD*/A
28	PB6	29	SLOT0SEL*
29	PB7	37	SERCLK
31	PC1	26	SERDATOUT
32	PC2	28	No Connect
40	EXTCONV*	36	SCANCLK
43	OUTB1	46	No Connect
49	+5 V	34-35	No Connect

All other pins of the Lab board pinout are not sent to the SCXI-1100 rear signal connector.

SCXI-1341 and SCXI-1344 Installation

Perform the following steps to install the SCXI-1341 and SCXI-1344:

1. Make sure that the computer and the SCXI chassis are turned off.
2. Install the SCXI module in the chassis.
3. Connect one end of the ribbon cable to the adapter board rear connector. This is the 50-pin connector of the SCXI-1344 cable.
4. Plug the adapter board front connector to the module rear signal connector. Make sure the corner of the adapter board enters the upper board guide of the chassis.
5. Screw the rear panel to the threaded strips in the rear of the chassis.
6. For an SCXI-1341, connect the loose end of the ribbon cable to the Lab-NB, Lab-PC, or Lab-PC+ I/O connector. For an SCXI-1344, connect the two 26-pin connectors to the Lab-LC board according to the instructions given in the *Installation* section of Chapter 2, *Configuration and Installation*, of the *Lab-LC User Manual*.

Check the installation.

SCXI-1342 PC-LPM-16 Cable Assembly

The SCXI-1342 PC-LPM-16 cable assembly connects a PC-LPM-16 board to an SCXI-1100 module. The SCXI-1342 cable assembly consists of two pieces—an adapter board and a 50-conductor ribbon cable connects the PC-LPM-16 board to the adapter board. The adapter board converts the signals from the PC-LPM-16 I/O connector to a format compatible with the SCXI-1100 rear signal connector pinout. The adapter board also has an additional male breakout connector that provides the unmodified PC-LPM-16 signals for use with an SCXI-1180 feedthrough panel or an SCXI-1181 breadboard module. The adapter board gives the PC-LPM-16 board full access to the digital control lines, but the PC-LPM-16 can take only single measurements and cannot scan channels. Leave jumper W1 in position A on the SCXI-1342. The SCXI-1100 does not use jumper W1. Table E-3 lists the SCXI-1342 pin translations.

Table E-3. SCXI-1342 Pin Translations

PC-LPM-16 Pin	PC-LPM-16 Signal	Rear Signal Connector Pin	SCXI-1100 Use
1-2	AIGND	1-2	AOGND
3	ACH0	3	MCH0+
4	ACH8	4	MCH0-
5	ACH1	5	MCH1+
6	ACH9	6	MCH1-
7	ACH2	7	No Connect
8	ACH10	8	No Connect
9	ACH3	9	No Connect
10	ACH11	10	No Connect
11	ACH4	11	No Connect
12	ACH12	12	No Connect
13	ACH5	13	No Connect
14	ACH13	14	No Connect
15	ACH6	15	No Connect
16	ACH14	16	No Connect
17	ACH7	17	No Connect
18	ACH15	18	No Connect
19, 50	DGND	24, 33	DIG GND
28	DIN6	26	SERDATOUT
29	DIN7	28	No Connect
34	DOUT4	25	SERDATIN
35	DOUT5	27	DAQD*/A
36	DOUT6	29	SLOT0SEL*
37	DOUT7	37	SERCLK
46	OUT2	46	No Connect
49	+5 V	34-35	No Connect

All other pins of the PC-LPM-16 pinout are not sent to the SCXI-1100 rear signal connector.

SCXI-1342 Installation

Perform the following steps to install the SCXI-1342:

1. Make sure that the computer and the SCXI chassis are turned off.
2. Install the SCXI module to which the SCXI-1342 will connect.
3. Connect one end of the ribbon cable to the adapter board rear connector.
4. Plug the adapter board front connector onto the module rear signal connector. Make sure the corner of the adapter board enters the upper board guide of the chassis.
5. Screw the rear panel to the threaded strips in the rear of the chassis.
6. Connect the loose end of the ribbon cable to the PC-LPM-16 I/O connector.

Check the installation.

AT-MIO-16D and AT-MIO-64F-5 Board Connection

To use your SCXI-1100 with an AT-MIO-16D or AT-MIO-64F-5 board, you need an NB5 cable. The NB5 cable is a ribbon cable with a 100-pin connector that mates with the data acquisition board rear signal connector. The other end of the cable is divided into two 50-pin connectors. Use positions 1 through 50 on the NB5 cable to connect to the SCXI-1100. This connector has an MIO-16 compatible pinout; the pin equivalences of the MIO board on this connector and the SCXI-1100 are given in Table E-1 in the *SCXI-1340 Cable Assembly* section earlier in this chapter. You can either connect the positions 1 through 50 connector of the NB5 cable directly to the SCXI-1100, or use an SCXI-1351 between the SCXI-1100 and the NB5 cable. The SCXI-1100 does not use positions 51 through 100 of the NB5 cable.

The SCXI-1351 has the following advantages over the ribbon cable:

- The SCXI-1351 includes a mounting bracket that mounts to the chassis so that you can remove and reinsert the module without explicitly removing the cable from the back of the chassis. This is especially useful when the SCXI chassis is rack mounted, making rear access difficult.
- The SCXI-1351 has an extra female connector for use with the SCXI-1180 feedthrough panel, additional modules, or breadboards that need a direct connection to the board.
- The SCXI-1351 rear panel gives the module and the chassis both mechanical and electrical shielding.

SCXI-1351 and NB5 Cable Installation

Perform the following steps to install the SCXI-1351:

1. Make sure that the computer and the SCXI chassis are turned off.
2. Install the SCXI module in the chassis.

3. Connect the positions 1 through 50 connector of the NB5 cable to the male breakout connector on the SCXI-1351.
4. Plug the mounting bracket connector onto the module rear signal connector (see Figure E-2). Make sure the alignment tab on the bracket enters the upper board guide of the chassis.
5. Screw the mounting bracket to the threaded strips in the rear of the chassis.
6. Connect the 100-pin connector of the NB5 cable to the board.

After step 1, the order of these steps is not critical; however, it is easier to locate the correct position for the mounting bracket with a module installed in the chassis. If you are attaching a cable to the female connector, installation is easiest if you attach the second cable before installing the SCXI-1351.

Note: If you are not using the SCXI-1351, omit steps 3, 4, and 5 in the instructions; instead, connect the positions 1 through 50 connector of the NB5 cable directly to the rear signal connector of the SCXI module.

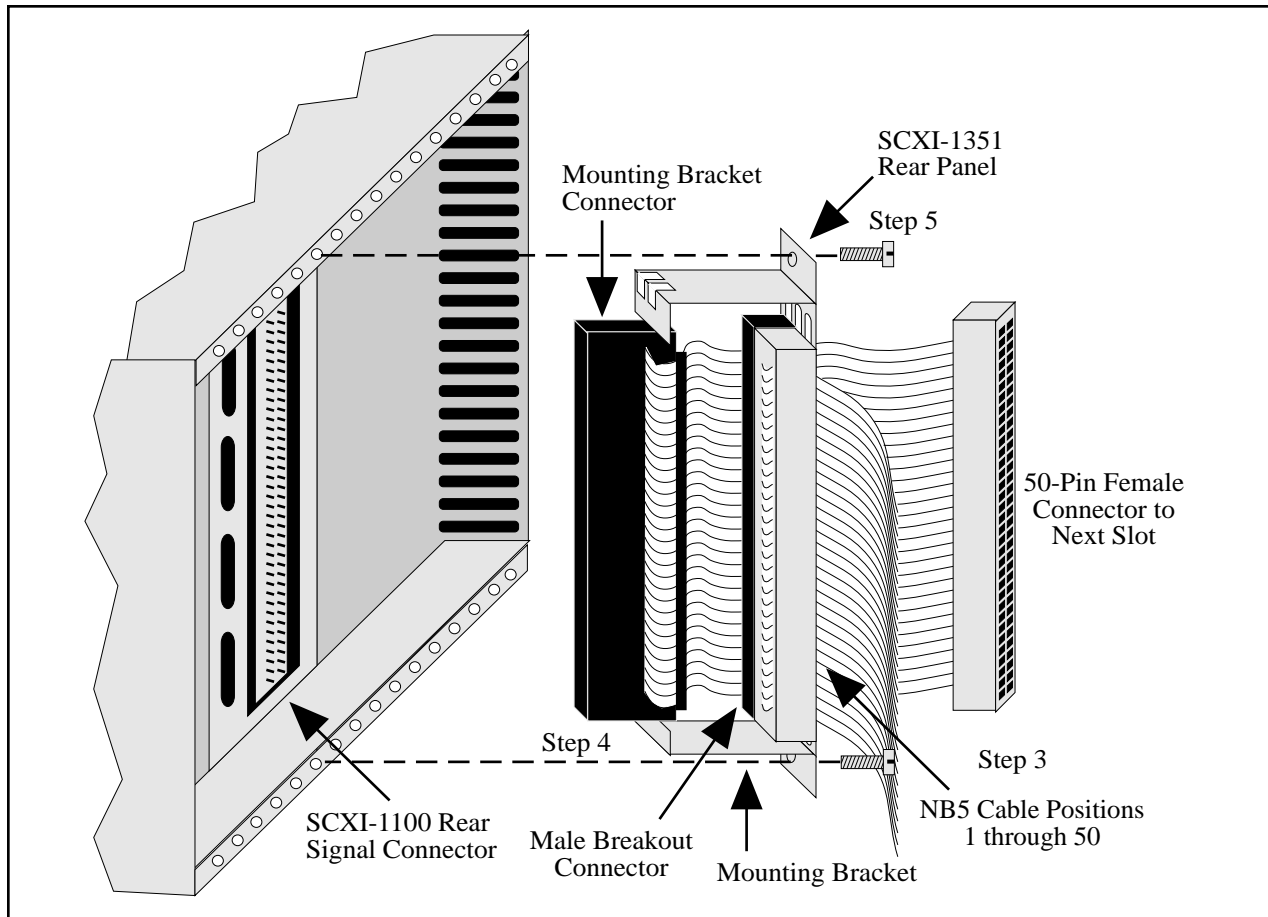

Figure E-2. NB5 Cable and SCXI-1351 Installation

SCXI-1180 Feedthrough Panel

The SCXI-1180 feedthrough panel gives front panel access to the signals of any data acquisition board that uses a 50-pin I/O connector. The SCXI-1180 consists of a front panel with a 50-pin male front panel connector that occupies one slot in the SCXI chassis, and a ribbon cable with a female rear connector and a male breakout connector. You can attach the rear connector to the male breakout connector of an SCXI-1340, SCXI-1341, SCXI-1342, SCXI-1344, or SCXI-1351 in the adjacent slot. The breakout connector further extends the cabling scheme. The front panel connector has the feedthrough connection. You can attach an SCXI-1302 terminal block to the front panel connector for simple screw terminal connections. A rear filler panel that shields and protects the interior of the SCXI chassis is also included.

SCXI-1180 Installation

Install the SCXI-1180 to the right of a slot that has an SCXI-1340, SCXI-1341, SCXI-1342, or SCXI-1344 cable assembly or an SCXI-1351 slot extender in its rear connector space.

Perform the following steps to install the SCXI-1180:

1. Make sure that the computer and the SCXI chassis are turned off.
2. Remove the front filler panel of the slot where you want to insert the SCXI-1180.
3. Thread the rear connector through the front of the chassis to the rear of the chassis. Attach the rear connector to the breakout connector of the adjacent cable assembly or slot extender, as shown in Figure E-3.

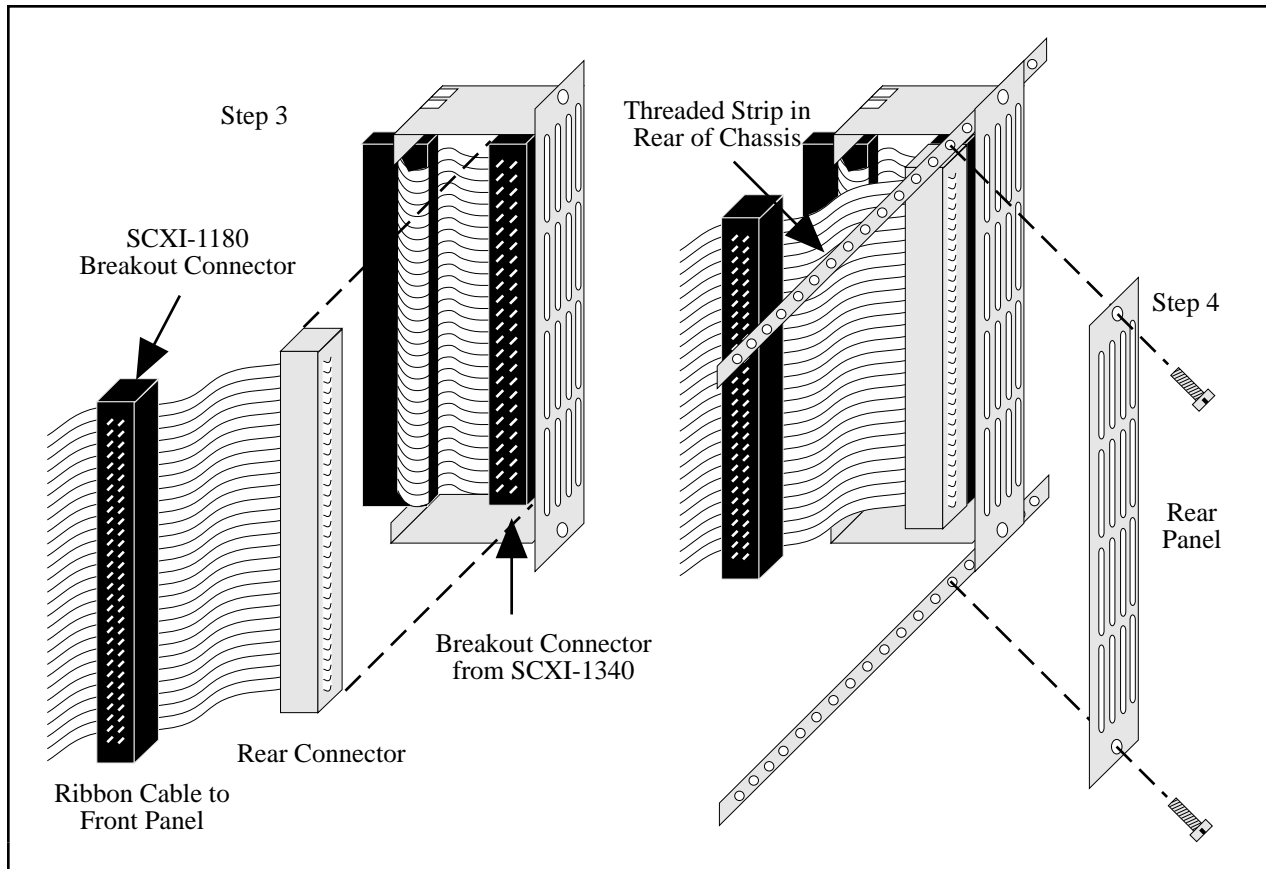

Figure E-3. SCXI-1180 Rear Connections

4. Screw in the rear panel to the threaded strip in the rear of the chassis.
5. Screw the front panel into the front threaded strip, as shown in Figure E-4.

Check the installation.

Note: If you are using the SCXI-1180 with an SCXI-1351 and an NB5 cable, connect the SCXI-1180 breakout connector to the female connector on the SCXI-1351. Place the SCXI-1180 to the *left* of the SCXI-1351 (looking at the front of the chassis).

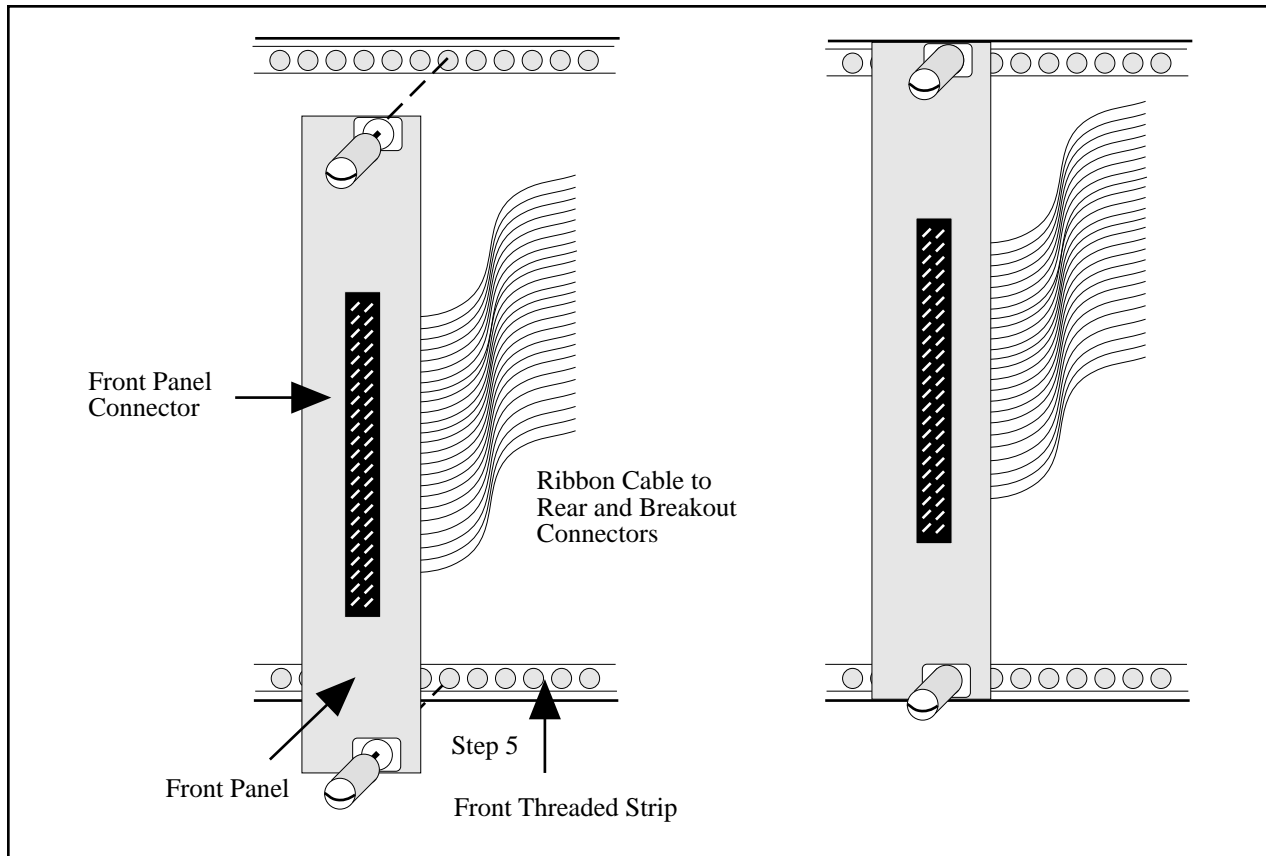

Figure E-4. SCXI-1180 Front Panel Installation

SCXI-1302 50-Pin Terminal Block

The SCXI-1302 terminal block has screw terminal connections for the 50-pin connector on the SCXI-1180 feedthrough panel.

SCXI-1302 Wiring Procedure

To wire the SCXI-1302 terminal block, you must remove the cover, connect all the wiring, and replace the cover. The procedure for this is as follows:

1. Unscrew the rear grounding screw on the back of the terminal block, as shown in Figure E-5.
2. With a flathead screwdriver, carefully pry the cover off the terminal block.
3. Insert each wire through the terminal block strain relief.

4. Connect the wires to the screw terminals.
5. Tighten the large strain relief screws to secure the wires.
6. Snap the cover back in place.
7. Reinsert the rear grounding screw. The terminal block is now ready to be connected to the front panel connector.

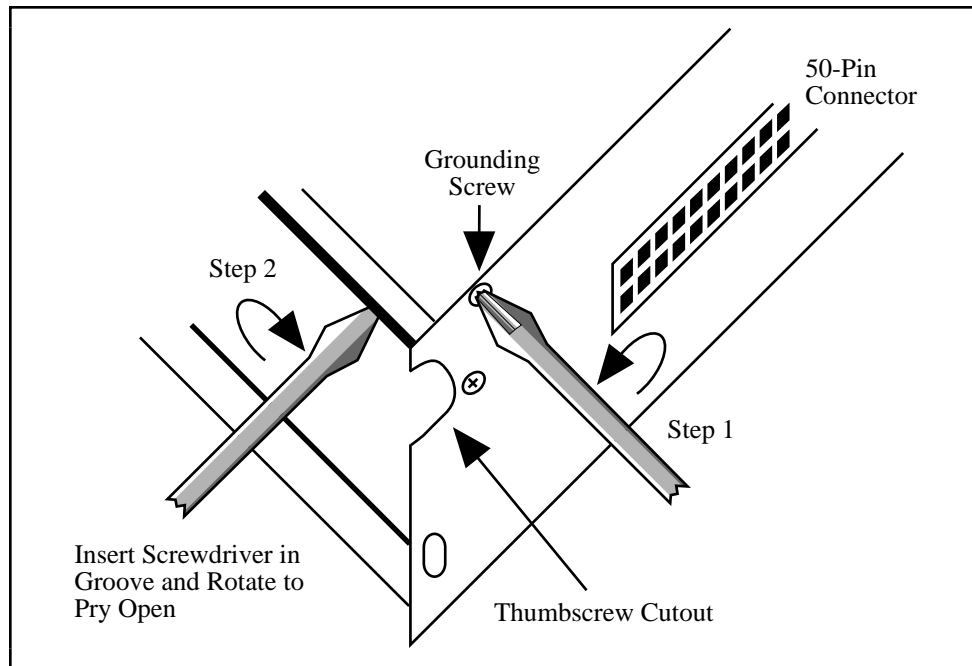

Figure E-5. Cover Removal

SCXI-1302 Installation

Perform the following steps to install the SCXI-1302:

1. Install an SCXI-1180 feedthrough panel as described in the *SCXI-1180 Installation* section.
2. Wire the terminal block as described previously in the *SCXI-1302 Wiring Procedure* section.
3. Connect the SCXI-1302 terminal block to the front panel connector on the SCXI-1180 feedthrough panel. Be careful to fit the thumbscrews in the thumbscrew cutouts.
4. Tighten the top and bottom captive screws on the back of the terminal block into the screw holes in the front panel to hold the SCXI-1302 securely in place.

Check the installation.

SCXI-1351 One-Slot Cable Extender

The SCXI-1351 cable extender is a miniature SCXI-1340 cable assembly. Instead of connecting to an MIO board 1 m away, the SCXI-1351 female rear connector connects to a male breakout connector that must be in the rear connector space of the slot to the left. The SCXI-1351 has a female mounting bracket connector that mates with the rear signal connector of a module, and also has a male breakout connector on the ribbon cable for connecting to a feedthrough panel or more cable extenders.

You can also use the SCXI-1351 with an NB5 cable to connect an AT-MIO-16D or an AT-MIO-64F-5 to your SCXI module. If you use the SCXI-1351 with these MIO boards, read the *AT-MIO-16D and AT-MIO-64F-5 Board Connection* section earlier in this appendix instead.

SCXI-1351 Installation

Perform the following steps to install the SCXI-1351:

1. Make sure that the computer and the SCXI chassis are turned off.
2. Install the SCXI module in the chassis.
3. Connect the rear connector of the cable extender to the breakout connector in the adjacent slot. This attachment is similar to step 3 in the *SCXI-1180 Installation* section, as shown in Figure E-3.
4. Plug the mounting bracket connector to the module rear signal connector. Make sure the alignment tab on the bracket enters the upper board guide of the chassis.
5. Screw the mounting bracket to the threaded strips in the rear of the chassis.

Check the installation.

SCXI-1350 Multichassis Adapter

You use the SCXI-1350 multichassis adapter to connect an additional SCXI-1001 chassis to the MIO-16 board. Using several SCXI-1350 modules, you can connect up to eight chassis to a single MIO board. The SCXI-1350 consists of a multichassis adapter board. You will also need a ribbon cable for each chassis-to-chassis connection, and a ribbon cable for the connection from the MIO board to the first chassis.

Note: When connecting multiple chassis, you should use a 0.5 m ribbon cable to minimize cable length and maintain signal integrity. You can use a 1.0 m cable from the MIO board to the first chassis.

The adapter board has a male rear connector, a female front connector, and a male chassis extender connector. You can attach the rear connector to a ribbon cable from the MIO board or a preceding chassis. You can connect the front connector with the module rear signal connector. You connect the chassis extender connector to a ribbon cable that goes to the subsequent chassis. The adapter takes channel 0 from the front connector and sends it to channel 0 of the rear connector. The adapter also takes channels 0 through 6 on the chassis extender connector and maps them to channels 1 through 7, respectively, on the rear connector.

SCXI-1350 Installation

Perform the following steps to install the SCXI-1350:

1. Make sure that the computer and all the SCXI chassis are turned off.
2. Insert all the modules in all the chassis.
3. Connect one end of a ribbon cable to the MIO board.
4. Connect the other end of the ribbon cable to the rear connector of the first SCXI-1350.
5. Connect another ribbon cable or cable assembly to the chassis extender connector.
6. Plug the adapter board front connector to the module rear signal connector. Make sure a corner of the adapter board enters the upper board guide of the chassis.
7. Screw the rear panel to the threaded strips in the rear of the chassis.
8. Connect the cable assembly to the desired module in the second chassis, or if you are using more than two chassis, connect the loose end of the ribbon cable to the rear connector of the second SCXI-1350, and install the adapter board.
9. Continue until all chassis are connected. For N chassis, you will need N ribbon cables and N multichassis adapters.

SCXI-1343 Rear Screw Terminal Adapter

You use the SCXI-1343 universal adapter to adapt custom wiring to the SCXI-1100. The SCXI-1100 has screw terminals for the analog output connections and solder pads for the rest of the signals. A strain-relief clamp is on the outside of the rear panel. Table E-4 shows the SCXI-1343 pin connections.

SCXI-1343 Installation

1. Insert each wire through through the adapter strain relief.
2. Make all solder connections first.
3. Connect the other wires to the screw terminals.
4. Tighten the strain-relief screws to secure the wires.
5. Plug the adapter board front connector to the module rear signal connector. Make sure the corner of the adapter board enters the upper board guide of the chassis.
6. Screw the rear panel to the threaded strips in the rear of the chassis.

Table E-4. SCXI-1343 Pin Connections

Rear Signal Connector Pin	SCXI-1100 Use	Connection Type
1	AOGND	Solder pad
2	AOGND	Screw terminal
3	MCH0+	Screw terminal
4	MCH0-	Screw terminal
5	MCH1+	Screw terminal
6	MCH1-	Screw terminal
7	No Connect	Screw terminal
8	No Connect	Screw terminal
9	No Connect	Screw terminal
10	No Connect	Screw terminal
11	No Connect	Screw terminal
12	No Connect	Screw terminal
13	No Connect	Screw terminal
14	No Connect	Screw terminal
15	No Connect	Screw terminal
16	No Connect	Screw terminal
17	No Connect	Screw terminal
18	No Connect	Screw terminal
19	OUTREF	Screw terminal
20	No Connect	Solder pad
21	No Connect	Solder pad
22	No Connect	Solder pad
23	No Connect	Solder pad
24, 33	DIG GND	Solder pad
26	SERDATOUT	Solder pad
27	DAQD*/A	Solder pad
28	No Connect	Solder pad
29	SLOT0SEL*	Solder pad
30	No Connect	Solder pad
31	No Connect	Solder pad
32	No Connect	Solder pad
33	No Connect	Solder pad
34-35	No Connect	Solder pad
36	SCANCLK	Solder pad
37	SERCLK	Solder pad
38	No Connect	Solder pad
39	No Connect	Solder pad
40	No Connect	Solder pad
41	No Connect	Solder pad
42	No Connect	Solder pad
43	RSVD	Solder pad
44	No Connect	Solder pad
45	No Connect	Solder pad
46	No Connect	Solder pad
47	No Connect	Solder pad
48	No Connect	Solder pad
49	No Connect	Solder pad
50	No Connect	Solder pad

Appendix F

Revision A and B Photo and Parts Locator Diagram

This appendix contains a photograph of the Revision A and B SCXI-1100 and the parts locator diagram.

Figure F-1 shows the Revision A and B SCXI-1100. Figure F-2 shows the parts locator diagram.

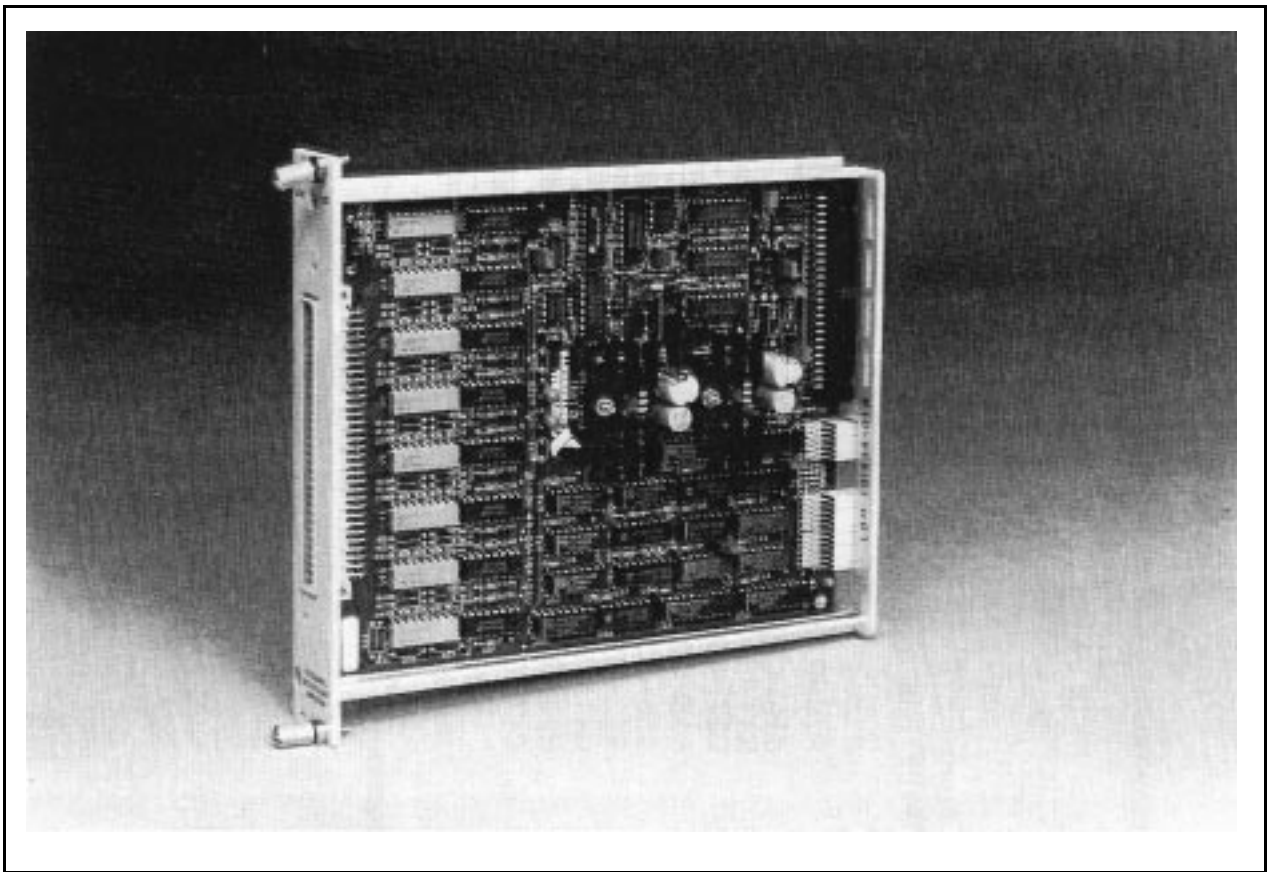

Figure F-1. Revision A and B SCXI-1100 Signal Conditioning Module

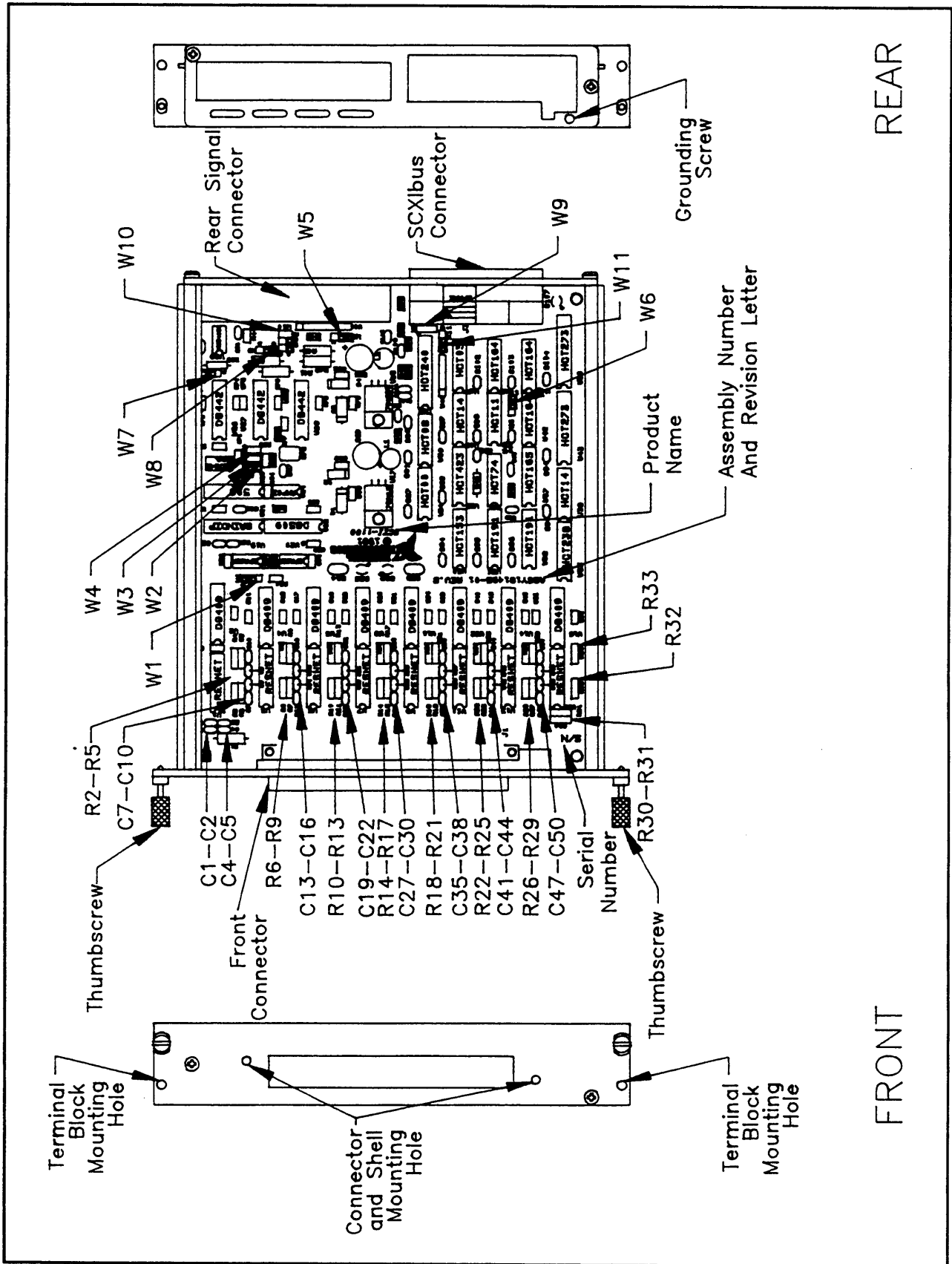

Figure F-2. Revision A and B SCXI-1100 Parts Locator Diagram

Appendix G

Customer Communication

For your convenience, this appendix contains forms to help you gather the information necessary to help us solve technical problems you might have as well as a form you can use to comment on the product documentation. Filling out a copy of the *Technical Support Form* before contacting National Instruments helps us help you better and faster.

National Instruments provides comprehensive technical assistance around the world. In the U.S. and Canada, applications engineers are available Monday through Friday from 8:00 a.m. to 6:00 p.m. (central time). In other countries, contact the nearest branch office. You may fax questions to us at any time.

Corporate Headquarters

(512) 795-8248

Technical support fax: (800) 328-2203

(512) 794-5678

Branch Offices	Phone Number	Fax Number
Australia	(03) 879 9422	(03) 879 9179
Austria	(0662) 435986	(0662) 437010-19
Belgium	02/757.00.20	02/757.03.11
Denmark	45 76 26 00	45 76 71 11
Finland	(90) 527 2321	(90) 502 2930
France	(1) 48 14 24 00	(1) 48 14 24 14
Germany	089/741 31 30	089/714 60 35
Italy	02/48301892	02/48301915
Japan	(03) 3788-1921	(03) 3788-1923
Mexico	95 800 010 0793	95 800 010 0793
Netherlands	03480-33466	03480-30673
Norway	32-848400	32-848600
Singapore	2265886	2265887
Spain	(91) 640 0085	(91) 640 0533
Sweden	08-730 49 70	08-730 43 70
Switzerland	056/20 51 51	056/20 51 55
Taiwan	02 377 1200	02 737 4644
U.K.	0635 523545	0635 523154

Technical Support Form

Photocopy this form and update it each time you make changes to your software or hardware, and use the completed copy of this form as a reference for your current configuration. Completing this form accurately before contacting National Instruments for technical support helps our applications engineers answer your questions more efficiently.

If you are using any National Instruments hardware or software products related to this problem, include the configuration forms from their user manuals. Include additional pages if necessary.

Name _____

Company _____

Address _____

Fax (____) _____ Phone (____) _____

Computer brand _____ Model _____ Processor _____

Operating system _____

Speed _____ MHz RAM _____ M Display adapter _____

Mouse _____ yes _____ no Other adapters installed _____

Hard disk capacity _____ M Brand _____

Instruments used _____

National Instruments hardware product model _____ Revision _____

Configuration _____

National Instruments software product _____ Version _____

Configuration _____

The problem is _____

List any error messages _____

The following steps will reproduce the problem _____

SCXI-1100 Hardware Configuration Form

Record the settings and revisions of your hardware on the line located to the right of each item. In addition, fill out the hardware and software configuration forms for the SCXI chassis and data acquisition board. Completing these forms accurately before contacting National Instruments for technical support helps our applications engineers answer your questions more efficiently.

- SCXI-1100 Revision Letter _____
- Chassis Slot _____
- Chassis Type _____
- Reference Mode Selection
(Factory Setting: parked, W1, 1-2) _____
- Filter Selection
(Factory Setting: no filter, W2) _____
- Grounding, Shielding, and Output Selection
(Factory Setting: parked, W10, A-R0R1) _____
- Input Filter Capacitors (Factory Default: not loaded)

Channel	0	1	2	3	4	5	6	7	8	9	10	11	12	13	14	15
Capacitor Value																
Channel	16	17	18	19	20	21	22	23	24	25	26	27	28	29	30	31
Capacitor Value																

- Current Receiver Resistors (Factory Default: not loaded)

Channel	0	1	2	3	4	5	6	7	8	9	10	11	12	13	14	15
Resistor Value																
Channel	16	17	18	19	20	21	22	23	24	25	26	27	28	29	30	31
Resistor Value																

- Other Modules in System _____

- Data Acquisition Boards Installed _____

Documentation Comment Form

National Instruments encourages you to comment on the documentation supplied with our products. This information helps us provide quality products to meet your needs.

Title: **SCXI-1100 User Manual**

Edition Date: **October 1994**

Part Number: **320637C-01**

Please comment on the completeness, clarity, and organization of the manual.

If you find errors in the manual, please record the page numbers and describe the errors.

Thank you for your help.

Name _____

Title _____

Company _____

Address _____

Phone (_____) _____

Mail to: Technical Publications
National Instruments Corporation
6504 Bridge Point Parkway, MS 53-02
Austin, TX 78730-5039

Fax to: Technical Publications
National Instruments Corporation
MS 53-02
(512) 794-5678

Index

Numbers/Symbols

+5 V signal, 2-13, 3-5, C-3, D-2

A

AB0- signal, 3-5, C-3

AB0+ signal, 3-5, C-3

AB2- signal, 3-5, C-3

AB2+ signal, 3-5, C-3

ABOEN bit, 4-5

analog and timing circuitry

analog input and timing circuits,
3-9 to 3-12

analog output circuitry, 3-13 to 3-14

block diagram, 3-10

calibration, 3-12 to 3-13

channel select hardware, 3-11

filters, 3-11 to 3-12

instrumentation amplifier, 3-11

multiplexer/input channel

correspondence, 3-11

MUXCOUNTER signal, 3-11

overview, 3-9

pad locations, 3-12

analog configuration

filter selection, 2-7 to 2-8

grounding, shielding, and output mode
selection, 2-5 to 2-6

input filtering and current loop receivers,
2-9 to 2-10

jumper W1, 2-7

jumper W10, 2-6 to 2-7

jumpers W2 through W4, 2-7 to 2-8

jumpers W7 and W8, 2-8 to 2-9

output selection, 2-8 to 2-9

reference mode selection, 2-7

user-defined current receiver
resistors, 2-10

user-defined input filter capacitors, 2-9

analog input and timing circuits, 3-9 to 3-12

analog input channels

AC-coupled signal connection, 2-15

exceeding input ranges (warning), 2-16

floating signal connection, 2-14

ground-referenced signal
connection, 2-14

signal connections, 2-13 to 2-16

analog input range, A-1

analog input specifications, A-1 to A-3

analog output circuitry, 3-13 to 3-14

analog output signal connections, 2-17, 2-24

AOGND signal

analog output, 2-24

description of, 2-23, B-2

AOREF signal

connecting to terminal block, 2-19

description of, 2-13, D-2

auto-calibration, 3-12 to 3-13

auto-zeroing, 3-12 to 3-13

B

bit descriptions

ABOEN, 4-5

CAL/ENM*, 4-4

CHAN<4..0>, 4-4

CHS<4..0>, 4-7

CLKEN, 4-8

CLKOUTEN, 4-4

CLKSELECT, 4-4

CNT<3..0>, 4-9

CV/ZERO*, 4-4

FOUTEN*, 4-5

FRT, 4-8

GAIN<4..0>, 4-3 to 4-4

HSRS*, 4-8

LOAD*, 4-8

MOD<3..0>, 4-9

ONCE, 4-8

RD, 4-8

RSVD, 4-5, 4-8

RTEMP, 4-5

SCANCLKEN*, 4-5

SCANCONEN, 4-5, 4-8

SL<3..0>, 4-7

board configuration. *See* configuration.

C

cabling

custom cables, 1-4

SCXI-1180 feedthrough panel

description of, E-8

front panel installation, E-10

installation, E-8 to E-9

- rear connections, E-9
- SCXI-1302 50-pin terminal block
 - installation, E-11
 - wiring procedure, E-10 to E-11
- SCXI-1340 cable assembly
 - description of, E-1 to E-2
 - installation, E-2 to E-3
 - pinout equivalences, E-2
- SCXI-1341 Lab-NB/Lab-PC/Lab-PC+
 - cable assembly
 - description of, E-3 to E-4
 - installation, E-4
 - pin translations, E-4
- SCXI-1342 PC-LPM-16 cable assembly
 - description of, E-5
 - installation, E-6
 - pin translations, E-5
- SCXI-1343 rear screw terminal adapter
 - installation, E-13
 - overview, E-13
 - pin connections, E-14
- SCXI-1344 Lab-LC cable assembly
 - description of, E-3 to E-4
 - installation, E-4
 - pin translations, E-4
- SCXI-1350 multichassis adapter
 - installation, E-13
 - overview, E-12
- SCXI-1351 one-slot cable extender
 - AT-MIO-16D and AT-MIO-64F-5
 - connection, E-6 to E-7
 - installation, E-12
 - overview, E-12
- CAL/ENM* bit, 4-4
- calibration
 - analog and timing circuitry, 3-12 to 3-13
 - auto-calibration, 3-12 to 3-13
- capacitors
 - installing, 2-10
 - user-defined input filter capacitors, 2-9
- CGND signal, 2-13, D-2
- CH0- through CH31- signal, 2-13, D-2
- CH0+ through CH31+ signal, 2-13, D-2
- CHAN<4..0> bit, 4-4
- chassis address, changing, 2-26
- CHS<4..0> bit, 4-7
- CHSGND signal, 3-5, C-3
- CJR. *See* cold-junction reference (CJR).
- CLKEN bit, 4-8
- CLKOUTEN bit, 4-4
- CLKSELECT bit, 4-4
- CNT<3..0> bit, 4-9
- cold-junction reference (CJR)
 - included on SCXI-1100, 1-1
 - specifications, A-3
- common-mode rejection ratio
 - specifications, A-2
- communication signals
 - communicating on Serial Peripheral Interface (SPI) bus, 2-26
 - DAQD*/A, 2-26 to 2-29
 - SERCLK, 2-26 to 2-29
 - SERDATIN, 2-26 to 2-29
 - SERDATOUT, 2-26 to 2-29
 - SLOT0SEL*, 2-26 to 2-29
 - SS* timing relationships, 2-26 to 2-29
- configuration. *See also* signal connections.
 - analog configuration
 - filter selection, 2-7 to 2-8
 - grounding, shielding, and output mode selection, 2-6 to 2-7
 - input filtering and current loop receivers, 2-9 to 2-10
 - jumper W1, 2-7
 - jumper W10, 2-6 to 2-7
 - jumpers W2 through W4, 2-7 to 2-8
 - jumpers W7 and W8, 2-8 to 2-9
 - output selection, 2-8 to 2-9
 - reference mode selection, 2-7
 - user-defined current receiver resistors, 2-10
 - user-defined input filter capacitors, 2-9
 - digital signal connections, 2-3 to 2-5
 - jumper settings (illustration), 2-5
 - jumper W5, 2-3 to 2-4
 - jumper W9, 2-4
 - jumper W11, 2-4 to 2-5
 - fixed jumpers, 2-3
 - parts locator diagram, 2-2
 - user-configurable jumpers, 2-3
- Configuration Register
 - description of, 4-3 to 4-5
 - digital control circuitry, 3-8
 - write timing diagram, 2-29
 - writing slot select number, 2-28
 - writing to registers, 5-1
- connections. *See* signal connections.
- connector-and-shell assembly
 - assembly steps, 2-17 to 2-18
 - illustration, 2-18
- cross talk specifications, A-2
- current loop receivers, 2-9 to 2-10
- customer communication, *xiii*, G-1
- CV/ZERO* bit, 4-4

D

- D*/A signal
 - description of, 3-5, C-3
 - equivalent to DAQD*/A signal, 3-6
 - DAQD*/A signal
 - description of, 2-23, B-2
 - register selection and write procedure, 5-2 to 5-3
 - SCXIBus equivalent, 3-6
 - selecting slots, 2-26 to 2-29
 - DIG GND signal
 - description of, 2-23, B-2
 - digital I/O line specifications and ratings, 2-25
 - digital control circuitry
 - Configuration Register, 3-8
 - illustration, 3-8
 - Module ID Register, 3-8 to 3-9
 - digital I/O signal connections
 - data acquisition board pin equivalences, 2-25
 - digital input signals, 2-24 to 2-25
 - digital output signals, 2-24 to 2-25
 - digital timing signals, 2-25
 - emulation of communication signals, 2-24
 - specifications and ratings, 2-25
 - digital interface circuitry, 3-7
 - digital signal connections, 2-3 to 2-5
 - jumper settings (illustration), 2-5
 - jumper W5, 2-3 to 2-4
 - jumper W9, 2-4
 - jumper W11, 2-4 to 2-5
 - documentation
 - conventions used in manual, *xii*
 - organization of manual, *xi* to *xii*
 - related documentation, *xiii*
 - DTEMP signal, 2-13, D-2
- E**
- equipment, optional, 1-3
- F**
- fax technical support, G-1
 - FIFO (First-In-First-Out) memory chip, 3-14
 - FIFO Register
 - description of, 4-9
 - writing to registers, 5-1
 - filtering specifications, A-2
 - FOUTEN* bit, 4-5
 - front connector
 - AC-coupled connection, 2-15
 - analog input channels, 2-13 to 2-16
 - analog output, 2-17
 - connector-and-shell assembly, 2-17 to 2-18
 - exceeding maximum ratings (warning), 2-11, 2-16
 - floating signal connection, 2-14
 - ground-referenced signal connections, 2-14
 - open thermocouple detection, 2-17
 - pin assignments, 2-12, D-1
 - signal connection descriptions, D-2
 - signal descriptions, 2-13
 - terminal block, 2-19 to 2-21
 - thermocouple connections, 2-16
 - FRT bit, 4-8
- G**
- gain error at DC, specifications, A-2
 - GAIN<4..0> bit, 4-3 to 4-4
 - GUARD signal, 2-13, 3-5, C-3, D-2
- H**
- hardscan circuitry, programming, 5-10 to 5-11
 - Hardscan Control Register
 - description of, 4-8
 - writing to registers, 5-1
 - hardware. *See also* cabling.
 - custom cables, 1-4
 - installation, 2-10 to 2-11
 - optional equipment, 1-3
 - unpacking, 1-4
 - HSRS* bit, 4-8
- I**
- initialization of registers, 5-3
 - input filtering, 2-9 to 2-10
 - input protection specifications, A-2
 - installation
 - capacitors and resistors, 2-10
 - hardware installation, 2-10 to 2-11
 - terminal block, 2-20
 - unpacking, 1-4
 - instrumentation amplifier
 - analog and timing circuitry, 3-11
 - specifications, A-1
 - INTR* signal
 - buffering of SLOT0SEL* line, 2-3
 - description of, 3-5, C-3
 - equivalent to SLOTSEL* signal, 3-6

J

jumper settings
 analog configuration
 filter selection, 2-7 to 2-8
 grounding, shielding, and output mode selection, 2-6 to 2-7
 jumper W1, 2-7
 jumper W10, 2-6 to 2-7
 jumpers W2 through W4, 2-7 to 2-8
 jumpers W7 and W8, 2-8 to 2-9
 output selection, 2-8 to 2-9
 reference mode selection, 2-7
 analog input channels, 2-13 to 2-16
 analog output signal connections, 2-24
 digital signal connections
 illustration, 2-5
 jumper W5, 2-3 to 2-4
 jumper W9, 2-4
 jumper W11, 2-4 to 2-5
 fixed jumpers, 2-3
 parts locator diagram, 2-2
 temperature sensor of terminal block, 2-19 to 2-20
 user-configurable jumpers, 2-3

L

LabVIEW software, 1-2
LabWindows software, 1-2
LOAD* bit, 4-8

M

MCH0 and MCH1 signal
 analog output, 2-17, 2-24
 analog output circuitry, 3-13 to 3-14
 description of, 2-23, B-2
measurements. *See* scanning measurements;
 single-channel measurements.
MISO signal
 buffering to SERDATOUT pin, 2-3
 description of, 3-5, C-3
 equivalent to SERDATOUT signal, 3-6
MOD<3..0> bit, 4-9
Module ID Register
 description of, 4-2
 digital control circuitry, 3-8 to 3-9
 reading from, 2-29
 timing diagram, 2-29
MOSI signal
 description of, 3-6, C-4
 equivalent to SERDATIN signal, 3-6

MTEMP signal
 analog output circuitry, 3-13
 connecting to temperature sensor, 2-19 to 2-20
 description of, 2-13, D-2
 measuring voltage, 5-5
multiple-chassis scanning
 programming considerations, 5-9 to 5-10
 theory of operation, 3-16
multiple-module multiplexed scanning
 programming considerations, 5-9
 theory of operation, 3-15 to 3-16
multiplexer/input channel
 correspondence, 3-11
MUXCOUNTER signal
 analog input and timing circuits, 3-10 to 3-11

incremented by SCANCLK, 2-26
scanning modes, 3-14 to 3-15

N

NB5 cable, E-6 to E-7
NI-DAQ software, 1-2
noise, specifications, A-2

O

offset voltage, specifications, A-2
offset voltage drift, specifications, A-2
ONCE bit, 4-8
open thermocouple detection, 2-17
operating environment specifications, A-3
operation of SCXI-1100

- analog and timing circuitry
 - analog input and timing circuits, 3-9 to 3-12
 - analog output circuitry, 3-13 to 3-14
 - block diagram, 3-10
- calibration, 3-12 to 3-13
 - multiplexer/input channel correspondence, 3-11
 - overview, 3-9
- block diagram of SCXI-1100, 3-1
- detailed block diagram of SCXI-1100, 3-2
- digital control circuitry, 3-8 to 3-9
- digital interface, 3-7
- functional overview, 3-1 to 3-3
- pinout of SCXIbus connector, 3-4
- scanning modes
 - multiple-chassis scanning, 3-16
 - multiple-module multiplexed scanning, 3-15 to 3-16
 - overview, 3-14
 - single-module multiplexed scanning (direct), 3-14 to 3-15
 - single-module multiplexed scanning (indirect), 3-15
- SCXIbus connector signal descriptions, 3-5 to 3-6, C-3 to C-4
- SCXIbus equivalents for rear signal connector, 3-6

OUTPUT signal

- connecting to terminal block, 2-19
- description of, 2-13, D-2

OUTREF signal

- analog output, 2-24

description of, 2-23, B-2

P

physical specifications, A-3
pin assignments

- front connector, 2-12, D-1
- rear signal connector, 2-22, B-1
- SCXIbus connector, 3-4, C-2

pin equivalences

- data acquisition board, 2-25
- rear signal connector pin equivalences, 5-2
- SCXI-1340 cable assembly pinout equivalences, E-2
- SCXI-1341 pin translations, E-4
- SCXI-1342 pin translations, E-5
- SCXI-1344 pin translations, E-4
- SCXIbus equivalents for rear signal connector, 3-6

power dissipation specifications, A-2
programming

- notation for bit patterns, 5-1
- register writes
 - initialization, 5-3
 - overview, 5-1
 - rear signal connector pin equivalences, 5-2
 - register selection and write procedure, 5-2 to 5-3
- scanning examples, 5-11 to 5-14
- scanning measurements
 - acquisition enable, triggering, and servicing, 5-11
 - data acquisition board setup, 5-6 to 5-8
 - general steps, 5-5
 - module programming, 5-8 to 5-10
 - Slot 0 hardscan circuitry, 5-10 to 5-11
- single-channel measurements
 - direct measurements, 5-3 to 5-4
 - indirect measurements, 5-4 to 5-5

R

RD bit, 4-8
rear signal connector

- analog output signal connections, 2-24
- applying external voltage (warning), 2-24
- communication signals, 2-26 to 2-29

- Configuration Register write timing
 - diagram, 2-29
- digital I/O signal connections,
 - 2-24 to 2-25
- Module ID Register timing
 - diagram, 2-29
- pin assignments, 2-22, B-1
- pin descriptions, 2-23, B-2
- pin equivalences, 5-2
- SCANCLK timing requirements, 2-26
- SCXIBus equivalents, 3-6
- serial data timing diagram, 2-28
- slot-select timing diagram, 2-27
- timing requirements, 2-26
- register descriptions
 - Configuration Register, 4-3 to 4-5
 - Module ID Register, 4-2
 - Slot 0 registers
 - FIFO Register, 4-9
 - Hardscan Control Register, 4-8
 - overview, 4-6
 - Slot-Select Register, 4-7
- register writes
 - initialization, 5-3
 - overview, 5-1
 - rear signal connector pin
 - equivalences, 5-2
 - register selection and write procedure,
 - 5-2 to 5-3
- registers
 - Configuration Register
 - description of, 4-3 to 4-5
 - digital control circuitry, 3-8 to 3-9
 - writing to registers, 2-28 to 2-29
 - Module ID Register
 - description of, 4-2
 - digital control circuitry, 3-8 to 3-9
 - writing to registers, 2-29
 - Slot 0 Registers
 - FIFO Register, 4-9, 5-1
 - Hardscan Control Register, 4-8, 5-1
 - overview, 4-6
 - programming slot 0 hardscan
 - circuitry, 5-8 to 5-10
 - Slot-Select Register, 2-27, 4-7
- RESET* signal, 3-5, C-3
- Reset button, 5-3
- resistors
 - installing, 2-10
 - user-defined current receiver
 - resistors, 2-10
- RSVD bit, 4-5, 4-8
- RSVD signal, 2-23, 3-5, B-2, C-3
- RTEMP bit, 4-5

S

- SCANCLK signal
 - analog input and timing circuits, 3-11
 - description of, 2-23, B-2
 - multiple-module multiplexed
 - scanning, 5-9
 - scanning modes, 3-14 to 3-16
 - timing requirements, 2-26
- SCANCLKEN* bit, 4-5
- SCANCON signal
 - analog input and timing circuits, 3-11
 - description of, 3-6, C-4
 - multiple-module multiplexed
 - scanning, 5-9
 - scanning modes, 3-14 to 3-16
- SCANCONEN bit, 4-5, 4-8
- scanning measurements
 - acquisition enable, triggering, and
 - servicing, 5-11
 - data acquisition board setup
 - Counter 1 and SCANDIV, 5-7
 - relevant documentation, 5-6
 - general steps, 5-5
 - module programming
 - channel scanning via another
 - module, 5-8 to 5-9
 - multiple-chassis scanning,
 - 5-9 to 5-10
 - multiple-module multiplexed
 - scanning, 5-9
 - single-module multiplexed scanning
 - (direct), 5-8
 - single-module multiplexed scanning
 - (indirect), 5-8 to 5-9
 - Slot 0 hardscan circuitry, 5-10 to 5-11
- scanning modes
 - multiple-chassis scanning, 3-16
 - multiple-module multiplexed scanning,
 - 3-15 to 3-16
 - overview, 3-14
 - single-module multiplexed scanning
 - direct, 3-14 to 3-15
 - indirect, 3-15
- scanning programming examples,
 - 5-11 to 5-14
- SCXI-1100. *See also* operation
 - of SCXI-1100.
 - contents of kit, 1-1
 - definition of, *xi*
 - optional equipment, 1-3
 - optional software, 1-2

- overview, 1-1
- Revision A and B, F-1 to F-2
- using with boards, 1-1
- SCXI-1180 feedthrough panel
 - description of, E-8
 - front panel installation, E-10
 - installation, E-8 to E-9
 - rear connections, E-9
- SCXI-1300 terminal block. *See* terminal block.
- SCXI-1302 50-pin terminal block
 - installation, E-11
 - wiring procedure, E-10 to E-11
- SCXI-1340 cable assembly
 - description of, E-1 to E-2
 - installation, E-2 to E-3
 - pinout equivalences, E-2
- SCXI-1341 Lab-NB/Lab-PC/Lab-PC+
 - cable assembly
 - description of, E-3 to E-4
 - installation, E-4
 - pin translations, E-4
- SCXI-1342 PC-LPM-16 cable assembly
 - description of, E-5
 - installation, E-6
 - pin translations, E-5
- SCXI-1343 rear screw terminal adapter
 - installation, E-13
 - overview, E-13
 - pin connections, E-14
- SCXI-1344 Lab-LC cable assembly
 - description of, E-3 to E-4
 - installation, E-4
 - pin translations, E-4
- SCXI-1350 multichassis adapter
 - installation, E-13
 - overview, E-12
- SCXI-1351 one-slot cable extender
 - AT-MIO-16D and AT-MIO-64F-5
 - connection, E-6 to E-7
 - installation, E-12
 - overview, E-12
- SCXIbus
 - equivalents for rear signal connector, 3-6
 - pinout of SCXIbus connector, 3-4, C-2
 - signal descriptions, 3-5 to 3-6, C-3 to C-4
- SERCLK signal
 - description of, 2-23, B-2
 - register selection and write procedure, 5-2 to 5-3
 - SCXIbus equivalent, 3-6
 - selecting slots, 2-26 to 2-29
 - timing requirements, 2-28
- SERDATIN signal
 - description of, 2-23, B-2
 - register selection and write procedure, 5-2 to 5-3
 - SCXIbus equivalent, 3-6
 - selecting slots, 2-26 to 2-29
 - timing requirements, 2-28
- SERDATOUT signal
 - description of, B-2
 - SCXIbus equivalent, 3-6
 - selecting slots, 2-26 to 2-29
- Serial Peripheral Interface (SPI) bus, 2-26
- settling time
 - definition of, A-3
 - specifications, A-1
- signal connections
 - front connector
 - AC-coupled connection, 2-15
 - analog input channels, 2-13 to 2-16
 - analog output, 2-17
 - connector-and-shell assembly, 2-17 to 2-18
 - exceeding maximum ratings (warning), 2-11, 2-16
 - floating signal connection, 2-14
 - ground-referenced signal connections, 2-14
 - open thermocouple detection, 2-17
 - pin assignments, 2-12, D-1
 - signal descriptions, 2-13, D-2
 - terminal block, 2-19 to 2-21
 - thermocouple connections, 2-16
 - rear signal connector
 - analog output connections, 2-24
 - applying external voltage (warning), 2-24
 - communication signals, 2-26 to 2-29
 - Configuration Register write timing diagram, 2-29
 - data acquisition board pin equivalents, 2-25
 - digital I/O connections, 2-24 to 2-25
 - Module ID Register timing diagram, 2-29
 - pin assignments, 2-22, B-1
 - pin descriptions, 2-23, B-2
 - pin equivalences, 5-2
 - SCANCLK timing requirements, 2-26
 - serial data timing diagram, 2-28
 - slot-select timing diagram, 2-27
 - timing requirements, 2-26
- SCXIbus connector signal descriptions, 3-5 to 3-6

- single-channel measurements
 - direct measurements, 5-3 to 5-4
 - indirect measurements
 - measurements from other modules, 5-4
 - measurements from SCXI-1100 via another module, 5-4 to 5-5
 - single-module multiplexed scanning
 - direct, 3-14 to 3-15, 5-8
 - indirect, 3-15, 5-8 to 5-9
 - from other modules, 5-8
 - from SCXI-1100 via another module, 5-8 to 5-9
 - SL<3..0> bit, 4-7
 - Slot 0 Registers
 - FIFO Register, 4-9
 - Hardscan Control Register, 4-8
 - overview, 4-6
 - programming slot 0 hardscan circuitry, 5-10 to 5-11
 - Slot-Select Register, 2-27, 4-7
 - SLOT0SEL* signal
 - buffering to INTR* line, 2-3
 - description of, 2-23, B-2
 - register selection and write procedure, 5-2 to 5-3
 - SCXIBus equivalent, 3-6
 - selecting slots, 2-26 to 2-29
 - slots
 - communication signals for selecting, 2-26 to 2-29
 - establishing communications, 3-6 to 3-7
 - slot-select timing diagram, 2-27
 - software, optional, 1-2
 - specifications
 - analog input, A-1 to A-3
 - explanation of, A-2 to A-3
 - cold-junction reference, A-3
 - common-mode rejection ratio, A-2
 - cross talk, A-2
 - digital I/O signal connections, 2-25
 - filtering, A-2
 - gain error at DC, A-2
 - input protection, A-2
 - instrumentation amplifiers, A-1
 - noise, A-2
 - offset voltage, A-2
 - offset voltage drift, A-2
 - operating environment, A-3
 - physical, A-3
 - power dissipation, A-2
 - settling time, A-1
 - storage environment, A-3
 - SPICLK signal
 - description of, 3-6, C-4
 - equivalent to SERCLK signal, 3-6
 - SS* signal
 - description of, 3-6, C-4
 - timing relationships, 2-26 to 2-29
 - storage environment specifications, A-3
- T**
- technical support, G-1
 - temperature sensor of terminal block
 - connections, 2-19 to 2-20
 - jumper configuration, 2-19 to 2-20
 - terminal block
 - installation, 2-20
 - jumper configuration, 2-19 to 2-20
 - parts locator diagram, 2-21
 - signal connection, 2-20
 - temperature sensor, 2-19
 - theory of operation. *See* operation of SCXI-1100.
 - thermocouple connections, 2-16
 - timing circuitry. *See* analog and timing circuitry.
 - timing requirements, 2-26. *See also* communication signals.
 - TRIG0 signal
 - description of, 3-6, C-4
 - scanning modes, 3-14 to 3-16
- U**
- unpacking the SCXI-1100, 1-4
- V**
- V- signal, 3-5, C-3
 - V+ signal, 3-5, C-3

Glossary

Prefix	Meaning	Value
p-	pico-	10 ⁻¹²
n-	nano-	10 ⁻⁹
μ-	micro-	10 ⁻⁶
m-	milli-	10 ⁻³
k-	kilo-	10 ³
M-	mega-	10 ⁶

Numbers/Symbols

°	degrees
Ω	ohms
+5 V (signal)	+5 VDC Source signal

A

AB#+	Positive Analog Bus Number signal
AB#-	Negative Analog Bus Number signal
AB0EN	Analog Bus 0 Enable bit
ACH#	data acquisition board analog input channel number
A/D	analog-to-digital
ADC	A/D converter
AOGND	Analog Output Ground signal
AOREF	Analog Output Reference signal
AWG	American Wire Gauge

B

BCD	binary-coded decimal
BW	bandwidth

C

C	Celsius
CAL/ENM*	Calibration/Multiplexer Select bit
CH#+	Positive Input Channel Number signal
CH#-	Negative Input Channel Number signal
CHS	Chassis bit
CGND	Chassis Ground signal
CHAN	Channel Select bit
CHSGND	Chassis Ground signal

Glossary

CJR	cold-junction reference
CLKEN	Clock Enable bit
CLKOUTEN	Scan Clock Output Enable bit
CLKSELECT	Scan Clock Select bit
CMRR	common-mode rejection ratio
CNT	Count bit
CV/ZERO*	Calibration Voltage/Zero Select bit

D

DAQD*/A	Data Acquisition Board Data/Address Line signal
D/A	digital-to-analog
D*/A	Data/Address signal
dB	decibels
DC	direct current
DIG GND	Digital Ground signal
DTEMP	Direct Temperature Sensor signal
DTS	direct temperature sensor

F

F	farads
FBW	full bandwidth
FIFO	first-in-first-out
FOUTEN*	Forced Output Enable bit
FRT	Forced Retransmit bit
FS	Full Scale
ft	feet

G

GAIN	Gain Select bit
GUARD	Guard signal

H

hex	hexadecimal
HSCR	Hardscan Control Register
HSRS*	Hardscan Reset bit
Hz	hertz

I

I_I	input current leakage
I_{in}	input current
in.	inches
I/O	input-output

I_{out}	output current
INTR*	Interrupt signal
K	
ksamples	1,000 samples
L	
LOAD*	Load bit
LPF	lowpass filter
LSB	least significant bit
M	
M	megabytes of memory
m	meters
MCH#+	Positive Analog Output Channel Number signal
MCH#-	Negative Analog Output Channel Number signal
MISO	Master-In-Slave-Out signal
MOD	Module Number bit
MOSI	Master-Out-Slave-In signal
MPW	Microsoft Programmer's Workshop
MSB	most significant bit
MTEMP	Multiplexed Temperature Sensor signal
MTS	multiplexed temperature sensor
N	
NRSE	nonreferenced single-ended (input)
O	
ONCE	Once bit
OUTPUT	Output signal
OUTREF	Output Reference signal
P	
PGIA	programmable gain instrumentation amplifier
ppm	parts per million
R	
RAM	random-access memory

Glossary

RD	Read bit
RESET*	Reset signal
rms	root mean square
RSE	referenced single-ended (input)
RSVD	Reserved bit/signal
RTD	resistance temperature detector
RTEMP	Read Temperature bit
RTI	Referred To Input
RTSI	Real-Time System Integration

S

SCANCLK	Scan Clock signal
SCANCLKEN*	Scan Clock Enable bit
SCANCON	Scanning Control signal
SCANCONEN	Scan Control Enable bit
SCXI	Signal Conditioning eXtensions for Instrumentation (bus)
SDK	Software Developer's Kit
sec	seconds
SERCLK	Serial Clock signal
SERDATIN	Serial Data In signal
SERDATOUT	Serial Data Out signal
SLOT	Slot bit
SLOT0SEL*	Slot 0 Select signal
SPDT	single-pole double throw
SPI	serial peripheral interface
SPICLK	Serial Peripheral Interface Clock signal
SS*	Slot Select signal

T

tempco	temperature coefficient
TRIG0	Trigger 0 signal

V

V	volts
V+	Positive Analog Supply signal
V-	Negative Analog Supply signal
VDC	volts direct current
VI	virtual instrument
V _{in}	volts in
V _{ofs}	offset voltage
V _{out}	volts out
V _{rms}	volts, root mean square

W

W	watts
---	-------