

DAQ

AMUX-64T User Manual

Analog Multiplexer with Temperature Sensor

Internet Support

E-mail: support@natinst.com

FTP Site: <ftp.natinst.com>

Web Address: <http://www.natinst.com>

Bulletin Board Support

BBS United States: 512 794 5422

BBS United Kingdom: 01635 551422

BBS France: 01 48 65 15 59

Fax-on-Demand Support

512 418 1111

Telephone Support (USA)

Tel: 512 795 8248

Fax: 512 794 5678

International Offices

Australia 03 9879 5166, Austria 0662 45 79 90 0, Belgium 02 757 00 20, Brazil 011 288 3336,
Canada (Ontario) 905 785 0085, Canada (Québec) 514 694 8521, Denmark 45 76 26 00, Finland 09 725 725 11,
France 01 48 14 24 24, Germany 089 741 31 30, Hong Kong 2645 3186, Israel 03 6120092, Italy 02 413091,
Japan 03 5472 2970, Korea 02 596 7456, Mexico 5 520 2635, Netherlands 0348 433466, Norway 32 84 84 00,
Singapore 2265886, Spain 91 640 0085, Sweden 08 730 49 70, Switzerland 056 200 51 51, Taiwan 02 377 1200,
United Kingdom 01635 523545

National Instruments Corporate Headquarters

6504 Bridge Point Parkway Austin, Texas 78730-5039 USA Tel: 512 794 0100

Important Information

Warranty

The AMUX-64T is warranted against defects in materials and workmanship for a period of one year from the date of shipment, as evidenced by receipts or other documentation. National Instruments will, at its option, repair or replace equipment that proves to be defective during the warranty period. This warranty includes parts and labor.

The media on which you receive National Instruments software are warranted not to fail to execute programming instructions, due to defects in materials and workmanship, for a period of 90 days from date of shipment, as evidenced by receipts or other documentation. National Instruments will, at its option, repair or replace software media that do not execute programming instructions if National Instruments receives notice of such defects during the warranty period. National Instruments does not warrant that the operation of the software shall be uninterrupted or error free.

A Return Material Authorization (RMA) number must be obtained from the factory and clearly marked on the outside of the package before any equipment will be accepted for warranty work. National Instruments will pay the shipping costs of returning to the owner parts which are covered by warranty.

National Instruments believes that the information in this document is accurate. The document has been carefully reviewed for technical accuracy. In the event that technical or typographical errors exist, National Instruments reserves the right to make changes to subsequent editions of this document without prior notice to holders of this edition. The reader should consult National Instruments if errors are suspected. In no event shall National Instruments be liable for any damages arising out of or related to this document or the information contained in it.

EXCEPT AS SPECIFIED HEREIN, NATIONAL INSTRUMENTS MAKES NO WARRANTIES, EXPRESS OR IMPLIED, AND SPECIFICALLY DISCLAIMS ANY WARRANTY OF MERCHANTABILITY OR FITNESS FOR A PARTICULAR PURPOSE. CUSTOMER'S RIGHT TO RECOVER DAMAGES CAUSED BY FAULT OR NEGLIGENCE ON THE PART OF NATIONAL INSTRUMENTS SHALL BE LIMITED TO THE AMOUNT THEREOF PAID BY THE CUSTOMER. NATIONAL INSTRUMENTS WILL NOT BE LIABLE FOR DAMAGES RESULTING FROM LOSS OF DATA, PROFITS, USE OF PRODUCTS, OR INCIDENTAL OR CONSEQUENTIAL DAMAGES, EVEN IF ADVISED OF THE POSSIBILITY THEREOF. This limitation of the liability of National Instruments will apply regardless of the form of action, whether in contract or tort, including negligence. Any action against National Instruments must be brought within one year after the cause of action accrues. National Instruments shall not be liable for any delay in performance due to causes beyond its reasonable control. The warranty provided herein does not cover damages, defects, malfunctions, or service failures caused by owner's failure to follow the National Instruments installation, operation, or maintenance instructions; owner's modification of the product; owner's abuse, misuse, or negligent acts; and power failure or surges, fire, flood, accident, actions of third parties, or other events outside reasonable control.

Copyright

Under the copyright laws, this publication may not be reproduced or transmitted in any form, electronic or mechanical, including photocopying, recording, storing in an information retrieval system, or translating, in whole or in part, without the prior written consent of National Instruments Corporation.

Trademarks

ComponentWorks™, LabVIEW™, Measure™, natist.com™, NI-DAQ™, RTSI™, SCXI™, and VirtualBench™ are trademarks of National Instruments Corporation.

Product and company names mentioned herein are trademarks or trade names of their respective companies.

WARNING REGARDING MEDICAL AND CLINICAL USE OF NATIONAL INSTRUMENTS PRODUCTS

National Instruments products are not designed with components and testing intended to ensure a level of reliability suitable for use in treatment and diagnosis of humans. Applications of National Instruments products involving medical or clinical treatment can create a potential for accidental injury caused by product failure, or by errors on the part of the user or application designer. Any use or application of National Instruments products for or involving medical or clinical treatment must be performed by properly trained and qualified medical personnel, and all traditional medical safeguards, equipment, and procedures that are appropriate in the particular situation to prevent serious injury or death should always continue to be used when National Instruments products are being used. National Instruments products are NOT intended to be a substitute for any form of established process, procedure, or equipment used to monitor or safeguard human health and safety in medical or clinical treatment.

Contents

About This Manual

Organization of This Manual	ix
Conventions Used in This Manual	x
National Instruments Documentation	xi
Related Documentation	xi
Customer Communication	xii

Chapter 1

Introduction

About the AMUX-64T	1-1
What You Need to Get Started	1-2
Unpacking	1-2
Software Programming Choices	1-2
LabVIEW and LabWindows Application Software	1-3
NI-DAQ Driver Software	1-3
Register-Level Programming	1-6
Optional Equipment	1-7

Chapter 2

Configuration and Installation

Board Configuration	2-1
Power, Temperature Sensor, and Shield Configuration	2-1
Supplementary Configuration Information	2-4
Power Supply Selection	2-4
Temperature Sensor	2-5
Shield Selection	2-6
Single-Board and Multiple-Board Configurations	2-7
Single-Board Configuration	2-9
Two-Board Configuration	2-9
Four-Board Configuration	2-9
Installation	2-10
Power-On Sequence	2-11

Chapter 3

Signal Connections

I/O Connector	3-1
Differential Connections	3-5

Using the AMUX-64T for Thermocouple Measurements	3-5
Selecting the Gain and Input Ranges	3-5
Linearizing the Data.....	3-6
Differential Measurements.....	3-9
An Example of Using Thermocouples (Differential or Single-Ended)	3-9
Procedure 1	3-10
Procedure 2	3-11
Comments	3-11
Single-Ended Measurement	3-11
Using More Than One AMUX-64T.....	3-12
Sources of Error	3-12
Thermocouple Measurement Accuracies.....	3-13
Other Connection Considerations.....	3-14

Chapter 4 Signal Conditioning

Analog Input.....	4-1
Application Notes.....	4-4
Soldering and Desoldering on the AMUX-64T Board	4-4
Channel Configurations	4-5
Connecting Nonreferenced or Floating Signal Sources	4-5
Differential Inputs.....	4-5
Single-Ended Inputs	4-6
Connecting Ground-Referenced Signal Sources.....	4-7
Differential Inputs.....	4-7
Single-Ended Inputs	4-7
Building Lowpass Filters	4-8
Building Highpass Filters.....	4-10
Building Attenuators (Voltage Dividers).....	4-12

Chapter 5 Theory of Operation and Register-Level Programming

Functional Overview	5-1
How to Address AMUX-64T Analog Input Channels	5-3
A/D Conversions on a Single AMUX-64T Analog Input Channel	5-3
Automatic Channel Scanning with the AMUX-64T	5-7
Scanning Order.....	5-10
Programming Channel Scanning with the AMUX-64T.....	5-11
Initialize the AMUX-64T Scanning Counter.....	5-11
Configure Counter 1 to Control the MIO Board Scanning Clock	5-12
Set the SCANDIV Bit in MIO Command Register 1	5-12

Appendix A Specifications

Appendix B Customer Communication

Glossary

Index

Figures

Figure 1-1.	The Relationship between the Programming Environment, NI-DAQ, and Your Hardware	1-5
Figure 2-1.	AMUX-64T Parts Locator Diagram.....	2-2
Figure 2-2.	Daisy-Chaining Multiple AMUX-64T Boards.....	2-8
Figure 2-3.	Cable Positioning for the AMUX-64T	2-11
Figure 3-1.	AMUX-64T Signal Routing	3-4
Figure 4-1.	Onboard Equivalent Circuit.....	4-2
Figure 4-2.	Bias Return Resistor for DC-Coupled Floating Source on Channel 1	4-6
Figure 4-3.	Normalized Frequency Response of Lowpass Filter.....	4-8
Figure 4-4.	Lowpass Filter on Differential Channel 1	4-9
Figure 4-5.	Normalized Frequency Response of Highpass Filter	4-10
Figure 4-6.	Highpass Filter on Differential Channel 1	4-12
Figure 4-7.	Attenuator for Use with Differential Inputs	4-13
Figure 5-1.	AMUX-64T Block Diagram	5-2
Figure 5-2.	Scanning Counter Control Bits.....	5-3
Figure 5-3.	AMUX-64T Channel Address Mapping	5-6
Figure 5-4.	Two-Level Multiplexer Arrangement Showing Channel 9 Selected	5-7
Figure 5-5.	Scanning Order for Different AMUX-64T Board Configurations.....	5-9

Tables

Table 2-1.	Power Supply Selection.....	2-3
Table 2-2.	Temperature Sensor Selection	2-3
Table 2-3.	Shield Selection	2-4
Table 2-4.	MIO Board Power Budget.....	2-5

Table 2-5.	Single- and Multiple-Board Configuration.....	2-7
Table 2-6.	Channel Ranges for Multiple AMUX-64T Boards.....	2-8
Table 2-7.	U12 Switch Settings for Two-Board Configuration	2-9
Table 2-8.	U12 Switch Settings for Four-Board Configuration	2-10
Table 3-1.	Pin Mapping for I/O Connectors J1, J2, and J42	3-2
Table 3-2.	Thermocouple Voltage Output Extremes (mV).....	3-6
Table 3-3.	NIST Polynomial Coefficients.....	3-8
Table 3-4.	Thermocouple Measurement Accuracies.....	3-13
Table 4-1.	Component Positions in Each Channel	4-2
Table 5-1.	AMUX-64T Channel Selection	5-4
Table 5-2.	Multiple AMUX-64T Board Addressing	5-5
Table 5-3.	AMUX-64T Scanning Order for Each MIO Board Input Channel	5-10

About This Manual

This manual describes the mechanical and electrical aspects of the AMUX-64T and contains information about configuring, operating, and programming the AMUX-64T. The AMUX-64T is a front-end analog multiplexer that quadruples the number of analog input signals that can be digitized with a National Instruments MIO board (except the AT-MIO-64). The AMUX-64T also has an integrated circuit temperature sensor that can be connected as a differential input to two of the 64 input channels (jumper-selectable) for low-cost thermocouple cold junction compensation. The AMUX-64T also has signal conditioning positions available for all 64 input channels.

Organization of This Manual

The *AMUX-64T User Manual* is organized as follows:

- Chapter 1, *Introduction*, describes the AMUX-64T; lists what you need to get started with your AMUX-64T; describes the software programming choices and optional equipment; and explains how to unpack your AMUX-64T.
- Chapter 2, *Configuration and Installation*, describes the configuration and installation of your AMUX-64T. The topics discussed include switch and jumper configuration, connection of the AMUX-64T board to the MIO board, power, and signal connections.
- Chapter 3, *Signal Connections*, describes the AMUX-64T signal connections and has specifications and connection instructions for the AMUX-64T connector signals.
- Chapter 4, *Signal Conditioning*, discusses signal conditioning and describes how to build systems such as filters and attenuators for passive analog input signal conditioning.
- Chapter 5, *Theory of Operation and Register-Level Programming*, contains a functional overview of the AMUX-64T and explains the operation of each functional unit making up the AMUX-64T. This chapter also contains register-level programming information for the MIO board.
- Appendix A, *Specifications*, lists the specifications for the AMUX-64T.

- Appendix B, *Customer Communication*, contains forms you can use to request help from National Instruments or to comment on our products and manuals.
- The *Glossary* contains an alphabetical list and description of terms used in this manual, including abbreviations, acronyms, metric prefixes, mnemonics, and symbols.
- The *Index* contains an alphabetical list of key terms and topics in this manual, including the page where you can find each one.

Conventions Used in This Manual

The following conventions are used in this manual:



This icon to the left of bold italicized text denotes a note, which alerts you to important information.



This icon to the left of bold italicized text denotes a caution, which advises you of precautions to take to avoid injury, data loss, or a system crash.



This icon to the left of bold italicized text denotes a warning, which advises you of precautions to take to avoid being electrically shocked.

bold italic

Bold italic text denotes a note, caution, or warning.

italic

Italic text denotes emphasis, a cross reference, or an introduction to a key concept.

E Series

Refers to MIO and AI boards, such as the AT-MIO-16XE-10, NB-MIO-16, NEC-AI-16E-4, and AT-AI-16XE-10 boards.

MC

Refers to the Micro Channel Series computers.

MIO board

Refers to multichannel I/O DAQ boards that have MIO in their names, such as the AT-MIO-16, AT-MIO-16D, and NEC-MIO-16E-4

monospace

Text in this font denotes text or characters that you should literally enter from the keyboard, programming examples, and syntax examples. This font is also used for device names, functions, variables, filenames, and extensions, and for statements and comments taken from program code.

NB

NB refers to the NuBus series computers.

PC

PC refers to the IBM PC/XT, the IBM PC AT, and compatible computers.

National Instruments Documentation

The *AMUX-64T User Manual* is one piece of the documentation set for your system. You could have any of several types of documentation, depending on the hardware and software in your system. Use the different types of documentation you have as follows:

- Your DAQ hardware user manuals—These manuals have detailed information about the DAQ hardware that plugs into or is connected to your computer. Use these manuals for hardware installation and configuration instructions, specification information about your DAQ hardware, and application hints.
- Software documentation—Examples of software manuals you may have are the LabVIEW and LabWindows/CVI, Virtual Bench, Component Works, Measure, and NI-DAQ documentation. After you set up your hardware system, use either your application software documentation or the NI-DAQ documentation to help you write your application. If you have a large and complicated system, it is worthwhile to look through the software documentation before you configure your hardware.
- Accessory installation guides or manuals—If you are using accessory products, read the terminal block and cable assembly installation guides or accessory board user manuals. They explain how to physically connect the relevant pieces of the system. Consult these guides when you are making your connections.

Related Documentation

The following document contains information you may find helpful as you read this manual:

- *NIST Monograph 175: Temperature-Electromotive Force Reference Functions and Tables for the Letter-Designated Thermocouple Types Based on the ITS-90*, National Institute of Standards and Technology, 1993

The following document contains information you may find helpful as you read this manual and is available from National Instruments upon request:

- Application Note 043, *Measuring Temperature with Thermocouples*

In addition, the National Instruments DAQ board user manuals contain information you may find helpful as you read this manual.

Customer Communication

National Instruments wants to receive your comments on our products and manuals. We are interested in the applications you develop with our products, and we want to help if you have problems with them. To make it easy for you to contact us, this manual contains comment and configuration forms for you to complete. These forms are in Appendix B, *Customer Communication*, at the end of this manual.

Introduction

This chapter describes the AMUX-64T; lists what you need to get started with your AMUX-64T; describes the software programming choices and optional equipment; and explains how to unpack your AMUX-64T.

About the AMUX-64T

The AMUX-64T is a front-end analog multiplexer that quadruples the number of analog input signals that can be digitized with a National Instruments MIO board (except the AT-MIO-64). The AMUX-64T has 16 separate four-to-one analog multiplexer circuits. Four AMUX-64T boards can be cascaded to digitize up to 256 single-ended or 128 differential signals by one MIO board.

The AMUX-64T has an integrated circuit temperature sensor that can be connected as a differential input to two of the 64 input channels (jumper-selectable) for low-cost thermocouple cold-junction compensation. Cold-junction compensation is achieved by adding the temperature reading of the sensor to the temperature readings of thermocouples at the remaining 62 AMUX-64T input channels. You can cascade up to four AMUX-64T boards to increase the number of thermocouple inputs with cold-junction compensation to 248 in single-ended mode or 124 in differential mode.

The AMUX-64T also has open component positions on all 64 input channels. These positions are for building signal conditioning devices such as filters and attenuators.

**Note**

When an MIO board is referred to without an AT, MC, NB, NEC, or SB prefix, the reference applies to the AT, MC, NB, NEC, and SB versions of that board.

The AMUX-64T is a circuitboard assembly that is placed on a workbench or mounted in a 19-in. rack. You can configure the AMUX-64T to draw power from the MIO board or from an external +5 V supply. A red LED indicates when the board is powered on. Input signal leads are attached at screw terminals.

What You Need to Get Started

To set up and use your AMUX-64T, you will need the following:

- AMUX-64T board
- AMUX-64T User Manual*
- 0.2, 0.5, 1.0, or 2.0 m cable
- MIO board

Detailed specifications of the AMUX-64T are listed in Appendix A, [Specifications](#).

Unpacking

Your AMUX-64T board is shipped in an antistatic package to prevent electrostatic damage to the device. Electrostatic discharge can damage several components on the device. To avoid such damage in handling the device, take the following precautions:

- Touch the antistatic package to a metal part of your computer chassis before removing the device from the package.
- Remove the device from the package and inspect the device for loose components or any other sign of damage. Notify National Instruments if the device appears damaged in any way. *Do not* install or connect a damaged device in your computer or to your MIO device.
- *Never* touch the exposed pins of connectors.

Software Programming Choices

There are four options to choose from when programming your National Instruments DAQ and SCXI hardware. You can use LabVIEW, LabWindows, NI-DAQ, or register-level programming software.

Your accessory hardware kit does not include software. The AMUX-64T works with LabVIEW for Windows, LabVIEW for Macintosh, LabWindows for DOS, and LabWindows/CVI for Windows, NI-DAQ for PC compatibles, and NI-DAQ for Macintosh.

LabVIEW and LabWindows Application Software

LabVIEW and LabWindows are innovative program development software packages for data acquisition and control applications. LabVIEW uses graphical programming, whereas LabWindows enhances traditional programming languages. Both packages include extensive libraries for data acquisition, instrument control, data analysis, and graphical data presentation.

LabVIEW currently runs on four different platforms—AT/MC/EISA computers running Microsoft Windows, NEC computers running Windows, the Macintosh platform, and the Sun SPARCstation platform. LabVIEW features interactive graphics, a state-of-the-art user interface, and a powerful graphical programming language. The LabVIEW Data Acquisition VI Library, a series of VIs for using LabVIEW with National Instruments DAQ hardware, is included with LabVIEW. The LabVIEW Data Acquisition VI Libraries are functionally equivalent to the NI-DAQ software, except that the SCXI functions are not included in the LabVIEW software for Sun.

LabWindows has two versions—LabWindows for DOS is for use on PCs running DOS, and LabWindows/CVI is for use on PCs running Windows and for Sun SPARCstations. LabWindows/CVI features interactive graphics, a state-of-the-art user interface, and uses the ANSI standard C programming language. The LabWindows Data Acquisition Library, a series of functions for using LabWindows with National Instruments DAQ hardware, is included with the NI-DAQ software kit. The LabWindows Data Acquisition libraries are functionally equivalent to the NI-DAQ software except that the SCXI functions are not included in the LabWindows/CVI software for Sun.

Using LabVIEW or LabWindows software will greatly reduce the development time for your data acquisition and control application.

NI-DAQ Driver Software

The NI-DAQ driver software is included at no charge with all National Instruments DAQ hardware. NI-DAQ is not packaged with SCXI or accessory products, except for the SCXI-1200. NI-DAQ has an extensive library of functions that you can call from your application programming environment. These functions include routines for analog input (A/D conversion), buffered data acquisition (high-speed A/D conversion), analog output (D/A conversion), waveform generation, digital I/O, counter/timer operations, SCXI, RTSI, self calibration, messaging, and acquiring data to extended memory.

NI-DAQ has both high-level *DAQ I/O* functions for maximum ease of use and low-level data acquisition I/O functions for maximum flexibility and performance. Examples of high-level functions are streaming data to disk or acquiring a certain number of data points. An example of a low-level function is writing directly to registers on the data acquisition device. NI-DAQ does not sacrifice the performance of National Instruments data acquisition devices because it lets multiple devices operate at their peak performance—up to 500 kS/s on ISA computers and up to 1 MS/s on EISA computers.

NI-DAQ includes a *Buffer and Data Manager* that uses sophisticated techniques for handling and managing data acquisition buffers so that you can simultaneously acquire and process data. NI-DAQ functions for the DAQCard-DIO-24 can transfer data using interrupts or software polling.

With the NI-DAQ *Resource Manager*, you can simultaneously use several functions and several DAQ devices. The Resource Manager prevents multiple-device contention over DMA channels, interrupt levels, and RTSI channels.

NI-DAQ can send *event-driven messages* to DOS, Windows, or Windows NT applications whenever a user-specified event occurs. Thus, polling is eliminated and you can develop event-driven data acquisition applications. An example of an NI-DAQ user event is when a specified digital I/O pattern is matched.

NI-DAQ also internally addresses many of the complex issues between the computer and the DAQ hardware such as programming the PC interrupt and DMA controllers. NI-DAQ maintains a consistent software interface among its different versions so that you can change platforms with minimal modifications to your code.

Figure 1-1 illustrates the relationship between NI-DAQ and LabVIEW and LabWindows. You can see that the data acquisition parts of LabVIEW and LabWindows are functionally equivalent to the NI-DAQ software.

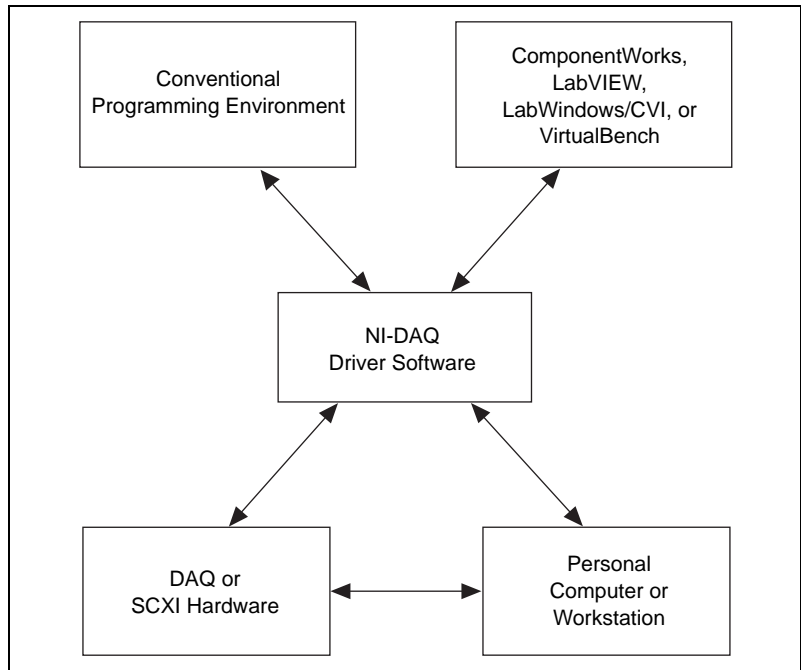

Figure 1-1. The Relationship between the Programming Environment, NI-DAQ, and Your Hardware

The National Instruments PC, AT, MC, DAQCard, and DAQPad Series DAQ hardware is packaged with NI-DAQ software for PC compatibles. NI-DAQ software for PC compatibles comes with language interfaces for Professional BASIC, QuickBASIC, Visual Basic, Borland Turbo Pascal, Turbo C++, Borland C++, Microsoft Visual C++, and Microsoft C for DOS; and Visual Basic, Turbo Pascal, Microsoft C with SDK, and Borland C++ for Windows and Microsoft Visual C++ for Windows NT. You can use your AMUX-64T, together with other PC, AT, MC, EISA, DAQCard, and DAQPad Series DAQ and SCXI hardware, with NI-DAQ software for PC compatibles.

The National Instruments NB Series DAQ boards are packaged with NI-DAQ software for Macintosh. NI-DAQ software for Macintosh comes with language interfaces for MPW C, THINK C, Pascal, and Microsoft QuickBASIC. Any language that uses Device Manager Toolbox calls can access NI-DAQ software for Macintosh. You can use NB Series DAQ boards and SCXI hardware with NI-DAQ software for Macintosh.

The National Instruments SB Series DAQ boards are packaged with NI-DAQ software for Sun, which comes with a language interface for ANSI C.

Register-Level Programming

The final option for programming any National Instruments DAQ hardware is to write register-level software. Writing register-level programming software can be very time-consuming and inefficient, and is not recommended for most users. The *only* users who should consider writing register-level software should meet at least one of the following criteria:

- National Instruments does not support your operating system or programming language.
- You are an experienced register-level programmer who is more comfortable writing your own register-level software.

Even if you are an experienced register-level programmer, always consider using NI-DAQ, LabVIEW, or LabWindows to program your National Instruments DAQ hardware. Using the NI-DAQ, LabVIEW, or LabWindows software is easier than, and as flexible as, register-level programming, and can save you weeks of development time.

The *AMUX-64T User Manual* and your software manuals contain complete instructions for programming your AMUX-64T with NI-DAQ, LabVIEW, or LabWindows. For register-level programming information, see Chapter 5, *Theory of Operation and Register-Level Programming*. If you are using NI-DAQ with LabWindows, use this manual and your LabWindows software manual. If you are using LabVIEW, use your LabVIEW manual. If you are using NI-DAQ, LabVIEW, or LabWindows to control your board, you should not need the programming information in Chapter 5, *Theory of Operation and Register-Level Programming*.

Chapter 5, *Theory of Operation and Register-Level Programming*, contains low-level programming details, such as register maps, bit descriptions, and register programming hints, that you will need only for register-level programming.

Optional Equipment

Contact National Instruments to order any of the following optional equipment:

- CB-50 I/O connector (50-screw terminals) with 0.5 or 1.0 m cable
- SCB-68 I/O connector (68-screw terminals) with 0.5 or 1.0 m cable
- SH6868 shielded cable assembly with 1, 2, 5, or 10 m cable
- SH6850 shielded cable assembly with 1, 2, 5, or 10 m cable
- R6868 1 m ribbon cable assembly
- R6850 1 m ribbon cable assembly
- Rack-mount kit with acrylic plastic cover (single- or double-height)
- Rack-mount kit with metal wraparound cover (single- or double-height)

For more information about optional equipment available from National Instruments, refer to your National Instruments catalog or call the office nearest you.

Configuration and Installation

This chapter describes the configuration and installation of your AMUX-64T. The topics discussed include switch and jumper configuration, connection of the AMUX-64T to the MIO board, power, and signal connections.

Board Configuration

The AMUX-64T contains two sets of switches and three jumpers to change the multiplexer settings and power connection configurations of the board. These jumpers and switches are shown in Figure 2-1.

The five-position switch at U12 configures the AMUX-64T for single-board or multiple-board operation. Switch SW1 selects either the internal +5 V power from the MIO board or an external +5 V power source for the AMUX-64T. Jumper W1 optionally connects the onboard temperature sensor to Channels 0 and 32 of the AMUX-64T. Jumper W2 connects the AMUX-64T analog ground to the shield of a rack-mounted chassis. Jumper W3 connects the AMUX-64T 68-pin connector shield to the shield of a rack-mounted chassis.

Power, Temperature Sensor, and Shield Configuration

To configure the AMUX-64T board, use the three user-configurable jumpers (W1–W3) shown in the parts locator diagram, Figure 2-1. Tables 2-1 to 2-3 list the description and configuration of the user-configurable jumpers.

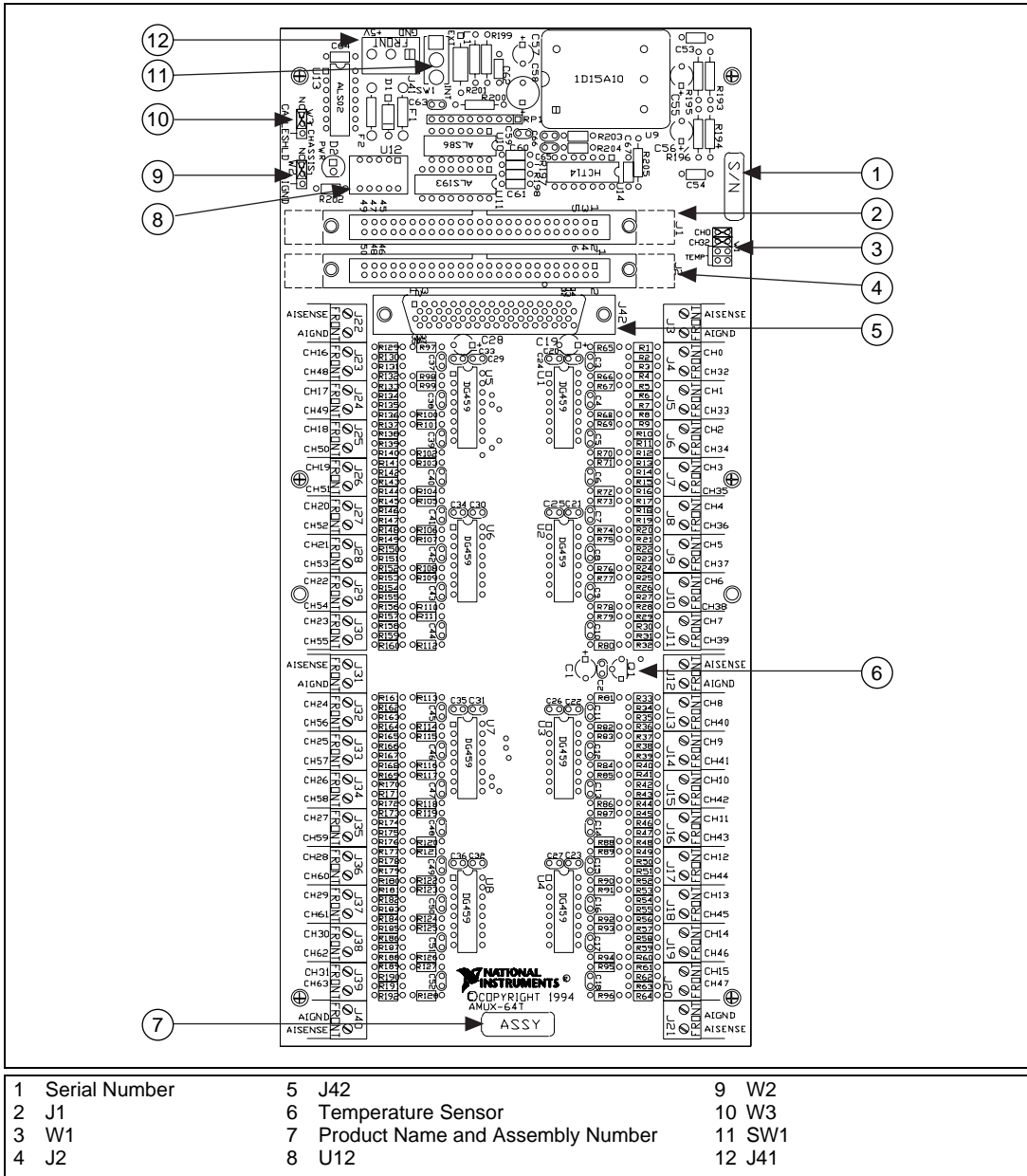

Figure 2-1. AMUX-64T Parts Locator Diagram

Table 2-1. Power Supply Selection



Switch	Description	Configuration
 <p>SW1</p>	<p>INT position—Use this setting to configure the AMUX-64T to draw +5 V power through the MIO board. (factory setting)</p> <p>EXT position—Use this setting to draw +5 V power from an external supply connected to connector J41.</p>	 <p>SW1</p> <p>INT</p> <p>EXT</p> <p>Internal Power Selected</p>  <p>SW1</p> <p>INT</p> <p>EXT</p> <p>External Power Selected</p>

Table 2-2. Temperature Sensor Selection

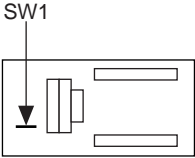

Jumper	Description	Configuration
 <p>W1</p>	<p>CH0 and CH32 position—Use this setting to select CH0 and CH32. (factory setting)</p> <p>Temp position—Use this setting to select the temperature sensor.</p>	 <p>CH0</p> <p>CH32</p> <p>Temp</p> <p>W1</p> <p>Channel 0 and 32 Selected (Factory Setting)</p>  <p>CH0</p> <p>CH32</p> <p>Temp</p> <p>W1</p> <p>Temperature Sensor Selected</p>

Table 2-3. Shield Selection

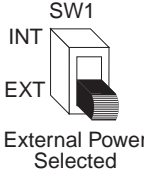
Jumper	Description	Configuration
	<p>No Connect position—Use this setting to disconnect the AMUX-64T analog ground from the shield of a rack-mounted chassis. (factory setting)</p> <p>AIGND position—Use this setting to connect the AMUX-64T analog ground to the shield of a rack-mounted chassis.</p>	
	<p>No Connect position—Use this setting to disconnect the AMUX-64T 68-pin connector shield from the shield of a rack-mounted chassis. (factory setting)</p> <p>CABLE SHLD position—Use this setting to connect the AMUX-64T 68-pin connector shield to the shield of a rack-mounted chassis.</p>	

 **Note** *The shaded area indicates the position of the jumper.*

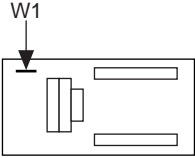
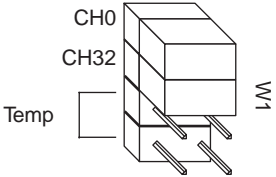
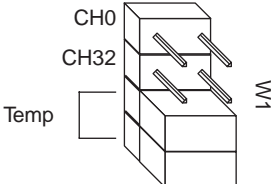
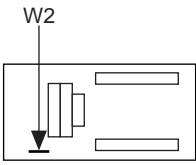
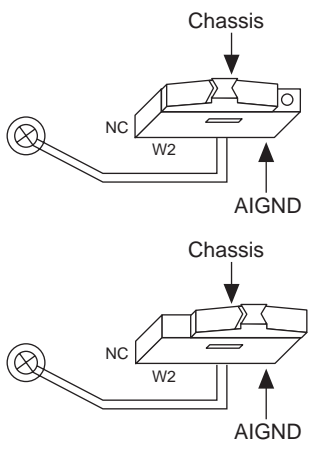
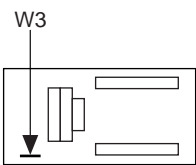
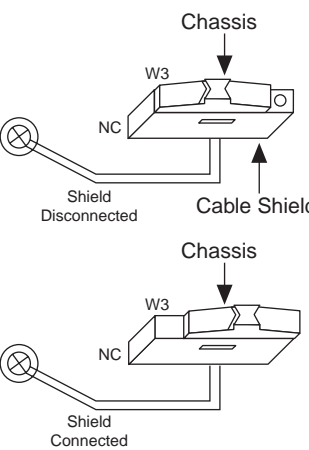
Supplementary Configuration Information

Power Supply Selection

Switch SW1 selects internal or external +5 V power for the AMUX-64T. Set SW1 to the INT position to power the AMUX-64T by drawing power through the MIO board. Set SW1 to the EXT position to draw power from an external +5 V source connected to J41.

With the exception of the MC-MIO-16, all MIO boards are capable of powering up to four AMUX-64T boards. The MC-MIO-16 has enough remaining power to start up to two AMUX-64T boards. Each AMUX-64T board typically draws 78 mA. Table 2-4 shows the amount of power the MIO boards can supply to the AMUX-64T.

Table 2-4. MIO Board Power Budget

Board	Power Allotted	Power Used	Power Remaining	Total Number of AMUX-64Ts That Can Be Powered through MIO Board
AT-MIO-16	no restriction*	1.5 A	1.0 A (limited by a fuse)	4
AT-MIO-16D	no restriction*	1.75 A	1.0 A (limited by a fuse)	4
AT-MIO-16F-5	no restriction*	1.6 A	1.0 A (limited by a fuse)	4
AT-MIO-16X	no restriction*	1.6 A	1.0 A (limited by a fuse)	4
E Series	no restriction*	1.0 A	1.0 A (limited by a fuse)	4
MC-MIO-16	1.6 A	1.4 A	0.2 A	2
NB-MIO-16	2.0 A	1.5 A	0.5 A	4
NB-MIO-16X	2.0 A	1.4 A	0.6 A	4
SB-MIO-16E-4	2.0 A	1.5 A	0.5 A	4
* This value depends on the computer model and configuration of other boards in the system.				

Temperature Sensor

Table 2-2 shows the positions for jumper W1.

The AMUX-64T is equipped with an onboard temperature sensor for use with thermocouple cold-junction compensation. This sensor is a National Semiconductor LM-35CZ that provides a voltage output of 10 mV/°C, with an accuracy of ± 1 °C. The sensor is jumper-selected on differential input channel 0.

Configure the host MIO board for differential inputs if you plan to use this temperature sensor. Use jumper W1 to select either the temperature sensor or the external screw terminals as the input source for differential channel 0. The AMUX-64T is shipped from the factory with the jumpers set so that CH0 and CH32 are connected to the terminal block (the temperature sensor is *not* selected).

Shield Selection

The AMUX-64T is shipped from the factory with the jumpers set so that AIGND and CABLE SHLD are disconnected from CHASSIS. Table 2-3 shows the jumper W2 and jumper W3 settings.

The AMUX-64T has two optional connections that are relevant when using a rack-mount kit to mount the AMUX-64T, jumpers W2 and W3. Jumper W2 connects the analog input ground (AIGND) to the rack-mount kit. Setting this jumper to the AIGND position connects the AIGND signal to the metal standoff in the lower left corner of the board. Setting this jumper to the NC position keeps the AMUX-64T AIGND isolated from the rack.

Jumper W3 connects the shield of the 68-position connector to the rack-mount kit. Setting this jumper to the CABLE SHLD position connects the shield of the 68-position connector to the metal standoff in the lower left corner of the board. Setting this jumper to the NC position keeps the computer chassis isolated from the rack.

Both jumpers' ground configurations may or may not be desired for your application.

For most applications, you should not connect the grounds together with these jumpers. Connecting jumper W3 may cause ground currents to flow between the computer chassis and the rack-mount chassis. These currents are likely to couple noise into the analog signals in the cabling. Connecting jumper W2 may cause ground currents to flow between the MIO board AIGND signal (measurement ground) and the rack-mount chassis. These currents directly interfere with measurements made with the analog signals, especially when the MIO board is in RSE mode.

If the rack-mount chassis is floating (that is, not earth-grounded), you should ground it. Ground the rack via a ground strap or other recommended ways. You may ground it using jumper W3. In general, you will get the best results if all grounds and shields have exactly one conduction path to earth ground.

Single-Board and Multiple-Board Configurations

The AMUX-64T is designed so that up to four AMUX-64T boards can be daisy-chained and connected to a single MIO board, as shown in Figure 2-2. You can configure the five-position switch labeled U12 according to the number of boards daisy-chained together. This switch is also used to assign distinct channel addresses to different AMUX-64T boards. Table 2-5 lists the description and configuration of the switches.

Note

In all of the following dual in-line package (DIP) switch illustrations, the dark-shaded end of the switch is the end that you press down.

Table 2-5. Single- and Multiple-Board Configuration

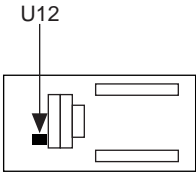
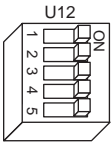
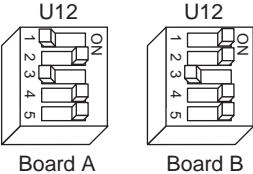
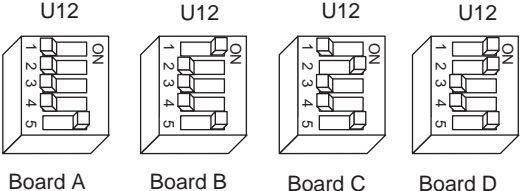
Jumper	Description	Configuration										
	U12—Set for single-board configuration. (factory setting).	 <table border="1" data-bbox="865 690 1143 743"> <tr> <td>SW1</td> <td>SW2</td> <td>SW3</td> <td>SW4</td> <td>SW5</td> </tr> <tr> <td>OFF</td> <td>OFF</td> <td>OFF</td> <td>OFF</td> <td>OFF</td> </tr> </table>	SW1	SW2	SW3	SW4	SW5	OFF	OFF	OFF	OFF	OFF
SW1	SW2	SW3	SW4	SW5								
OFF	OFF	OFF	OFF	OFF								
	U12—Set for two-board configuration.											
	U12—Set for four-board configuration.											

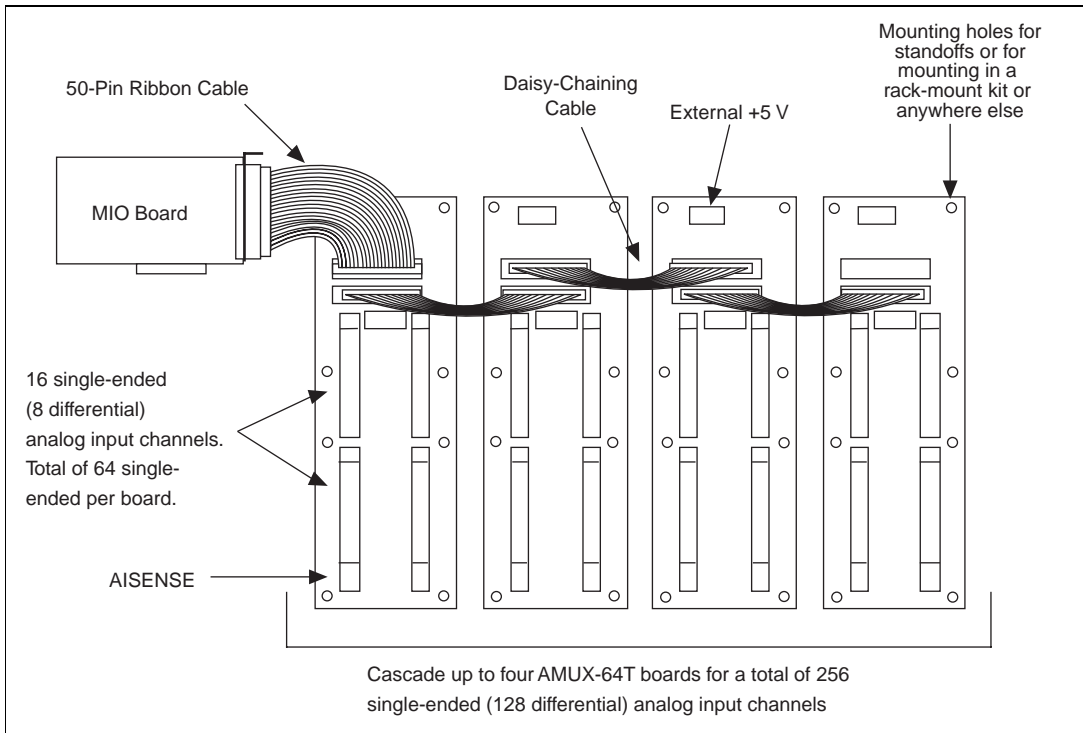

Figure 2-2. Daisy-Chaining Multiple AMUX-64T Boards

Table 2-6 lists the valid multiple-board configurations for both single-ended and differential modes.

Table 2-6. Channel Ranges for Multiple AMUX-64T Boards

Number of External Multiplexer Boards	Channel Range Single-Ended	Channel Range Differential
1	64	32
2	128	64
4	256	128

When you connect two or more AMUX-64T boards together, the multiplexers on different boards must be enabled at different times. Therefore, each board is assigned a different channel address range determined by the configuration of switch U12. The switch settings for each board configuration are given in the following sections.

Single-Board Configuration

The AMUX-64T is shipped from the factory with U12 set for single-board configuration as shown in Table 2-5.

Two-Board Configuration

For the two-board single-ended configuration, assign one board channel addresses from 0 to 63, and assign the other board channel addresses from 64 to 127. For differential operation, assign one board channel addresses 0 through 31 and assign the other board channel addresses 32 through 63. The board that you assign addresses 0 through 63 (or 0 through 31) is referred to as board A, and the board that you assign addresses 64 through 127 (or 32 through 63) is referred to as board B. You can configure any board as board A or board B, as shown in Table 2-7.

Table 2-7. U12 Switch Settings for Two-Board Configuration

Board	Channel Address Range		Switches				
	Single-Ended	Differential	SW1	SW2	SW3	SW4	SW5
Board A	0–63	0–31	ON	OFF	ON	OFF	OFF
Board B	64–127	64–95	OFF	OFF	ON	OFF	OFF

The switch settings for board A and board B in a two-board configuration are shown in Table 2-5.

Four-Board Configuration

For the four-board configuration, each board has a different switch setting. You assign the first board channel addresses from 0 to 63, the second board channel addresses from 64 to 127, the third board channel addresses from 128 to 191, and the fourth board channel addresses from 192 to 255. For differential operation, assign the first board channel addresses 0 through 31, the second board channel addresses 32 through 63, the third board channel addresses 64 through 95, and the fourth board channel addresses 96 through 127. The board that you assign addresses 0 through 63 (or 0 through 31) is referred to as board A; the board that you assign addresses 64 through 127 (or 32 through 63) is referred to as board B; the board that you assign addresses 128 to 191 (or 64 through 95) is referred to as board C; and the board that you assign addresses 192 through 255 (or 96 through 127) is referred to as board D. You can configure any board as board A, board B, board C, or board D, as shown in Table 2-8.

Table 2-8. U12 Switch Settings for Four-Board Configuration

Board	Channel Address Range		Switches				
	Single-Ended	Differential	SW1	SW2	SW3	SW4	SW5
Board A	0–63	0–31	ON	ON	ON	ON	OFF
Board B	64–127	64–95	OFF	ON	ON	ON	OFF
Board C	128–191	128–159	ON	OFF	ON	ON	OFF
Board D	192–255	192–223	OFF	OFF	ON	ON	OFF

The switch settings for boards A, B, C, and D in a four-board configuration are shown in Table 2-5.

Installation



Warning *Power off all units connected to your computer before you install the AMUX-64T.*

If you have a 50-pin MIO board, connect a 50-pin ribbon cable from the 50-pin MIO board I/O connector to either connector J1 or J2 on the AMUX-64T. If you have a 68-pin MIO board, connect a 68-pin shielded or ribbon cable from the 68-pin MIO board I/O connector to J42 on the AMUX-64T.

If you use more than one AMUX-64T, you can daisy-chain the boards by connecting J1 or J2 on one AMUX-64T to J1 or J2 on another AMUX-64T, and so on (see Figure 2-2).

You can install the AMUX-64T into a 19-in. rack-mount kit as shown in Figure 2-3. If you use a round 68-pin shielded cable, route the cable as shown, leaving passage for the ribbon cable (if you use it for daisy-chaining) in the other direction.

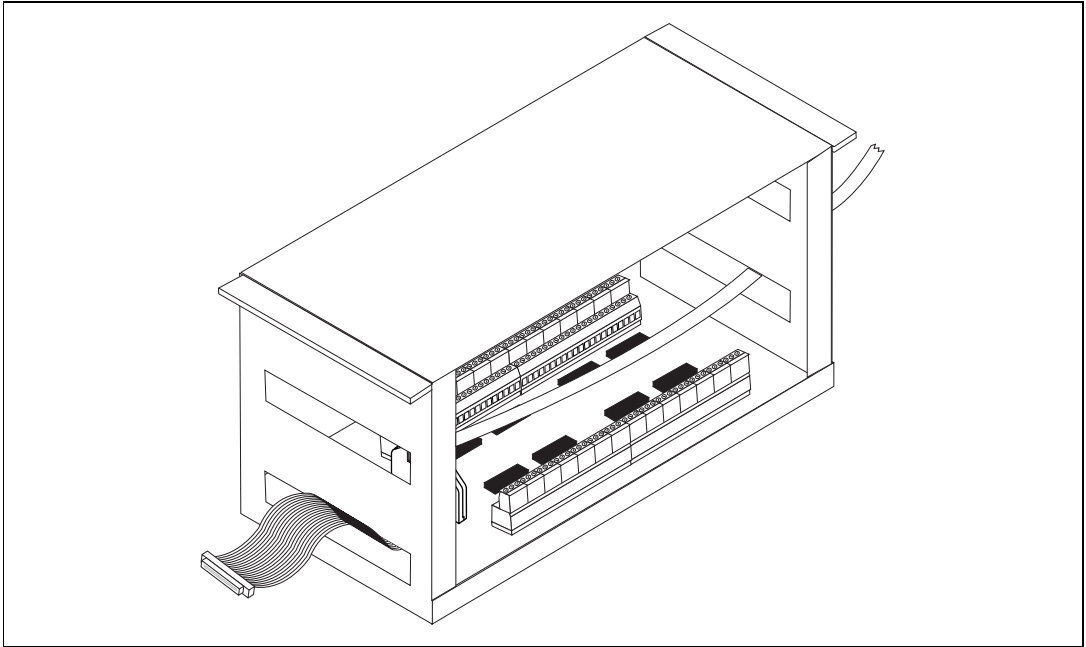

Figure 2-3. Cable Positioning for the AMUX-64T

Power-On Sequence

If the AMUX-64T is powered by an external power source, you must turn on power to the AMUX-64T *before* turning on the computer. Similarly, you must turn off power to the AMUX-64T *after* turning off the computer. The red LED, labeled D2, indicates when power is applied to the board.

Signal Connections

This chapter describes the AMUX-64T signal connections and has specifications and connection instructions for the AMUX-64T connector signals.

The following warnings contain important safety information concerning hazardous voltages.



Warning *Connections that exceed any of the maximum ratings of input signals on the AMUX-64T board can damage the AMUX-64T, the MIO board, or the computer. This includes connecting any power signals to ground and vice versa. Maximum input ratings are given in Appendix A, Specifications. National Instruments is NOT liable for any damages resulting from signal connections that exceed these ratings.*

DO NOT OPERATE DAMAGED EQUIPMENT. The safety-protection features built into this board can become impaired if the board becomes damaged in any way. If it is damaged, disconnect power and do not use the board until service-trained personnel can check its safety. If necessary, return the board to National Instruments for service and repair to ensure that its safety is not compromised.

DO NOT SUBSTITUTE PARTS OR MODIFY EQUIPMENT. Because of the danger of introducing additional hazards, do not install unauthorized parts or modify the board. Return the board to National Instruments for service and repair to ensure that its safety features are not compromised.



Caution *NEVER connect a signal to screw terminals CH0–CH63 that violates their overvoltage protection limits. When the AMUX-64T is powered on, the screw terminals CH0–CH63 overvoltage protection is ± 35 V; when the AMUX-64T is powered off, overvoltage protection is ± 20 V.*

I/O Connector

Connectors J1 and J2 are connected together pin by pin and have exactly the same pinout as the 50-pin MIO board I/O connector. J42 has the exact same pinout as the 68-pin MIO board I/O connector. Table 3-1 shows the pin mapping between J1, J2, and J42.

Table 3-1. Pin Mapping for I/O Connectors J1, J2, and J42

50-Pin Connector (J1 and J2) Pin Numbers	68-Pin Connector (J42) Pin Numbers
1, 2	24, 27, 29, 32, 56, 59, 64, 67
3	68
4	34
5	33
6	66
7	65
8	31
9	30
10	63
11	28
12	61
13	60
14	26
15	25
16	58
17	57
18	23
19	62
20	22
21	21
22	20
23	54, 55
24, 33	4, 7, 9, 12, 13, 15, 18, 35, 36, 39, 44, 50, 53

Table 3-1. Pin Mapping for I/O Connectors J1, J2, and J42 (Continued)

50-Pin Connector (J1 and J2) Pin Numbers	68-Pin Connector (J42) Pin Numbers
25	52
26	19
27	17
28	51
29	49
30	16
31	47
32	48
34, 35	8, 14
36	46
37	45
38	11
39	10
40	43
41	42
42	41
43	40
44	6
45	5
46	38
47	37
48	3
49	2
50	1

The signals from the AMUX-64T input connector screw terminals are connected to the MIO board via J1, J2, or J42 as shown in Figure 3-1. Observe that AISENSE is connected directly to the MIO board AISENSE pin and that AIGND on the AMUX-64T is connected to the AIGND signal of the MIO board.

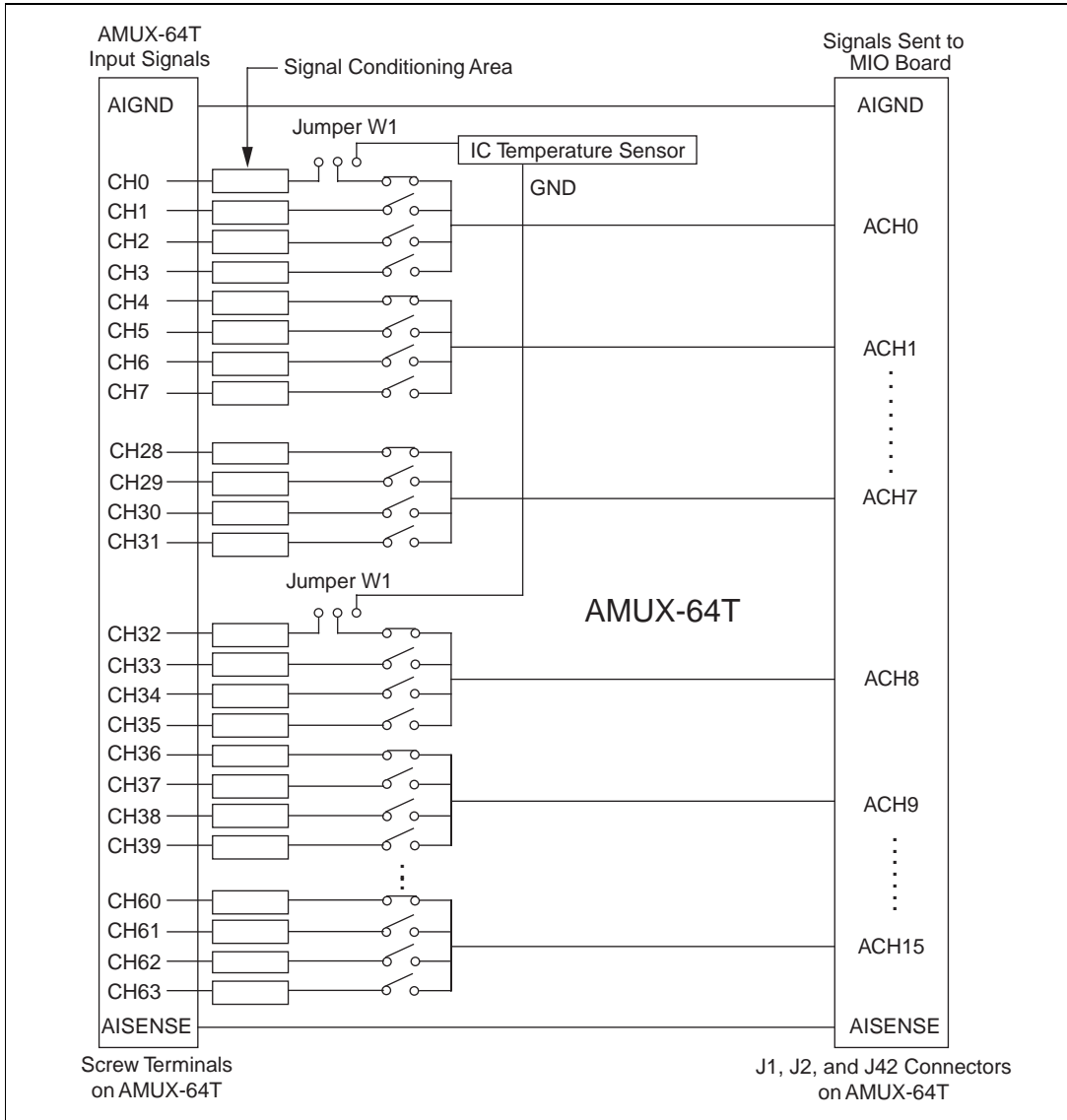

Figure 3-1. AMUX-64T Signal Routing

Differential Connections

On the AMUX-64T, channels 0 through 31 are connected to channels 0 through 7 of the MIO board. AMUX-64T channels 32 through 63 are connected to channels 8 through 15 of the MIO board. If the MIO board is configured for differential mode, the AMUX-64T input channels are automatically used in differential mode. The input screw terminals on the AMUX-64T are grouped together such that for differential mode, all input signals (SIG+) and the corresponding signal return path (SIG-) input appear directly next to each other. For example, signal return path for channel 0 is channel 32, and the signal return path for channel 31 is channel 63.

Using the AMUX-64T for Thermocouple Measurements

The AMUX-64T is equipped with a temperature sensor for thermocouple cold-junction compensation. Because thermocouple output voltages are typically a few millivolts, you must use a high-gain board (any speed) for best resolution. Thermocouples may be measured in either differential or single-ended configurations. Differential connection tends to yield the best results, but single-ended connection allows twice as many thermocouples to be used on each AMUX-64T.

The cold-junction compensation is accurate only if the temperature sensor reading is close to the temperature of the screw terminals. Therefore, when thermocouples are being read, you should keep the AMUX-64T away from drafts or other temperature gradients such as those caused by heaters, radiators, fans, very warm equipment, and so on.

Selecting the Gain and Input Ranges

Since thermocouple output voltages are very low, a gain of 500 or 100 is usually necessary for best resolution. You should set the input range on the MIO board to ± 5 V to improve resolution. You can use these settings in all but a few cases, such as a fairly high-output thermocouple type that is being used at elevated temperatures. Table 3-2 lists the voltage extremes from several popular thermocouple types. Use it as a guide for determining the best gain and input range settings to use. If you are using the thermocouples in a known temperature range, consult a book of thermocouple tables to determine the approximate millivolt output and the best gain and input range settings.



Caution *NEVER connect a signal to screw terminals CH0–CH63 that violates their overvoltage protection limits. When the AMUX-64T is powered on, the screw terminals CH0–CH63 overvoltage protection is ± 35 V; when the AMUX-64T is powered off, overvoltage protection is ± 20 V.*

Table 3-2. Thermocouple Voltage Output Extremes (mV)*

Thermocouple	Low	High
J	–8.095 at –210 °C**	69.553 at 1,200 °C**
K	–6.458 at –270 °C	54.886 at 1,372 °C
E	–9.835 at –270 °C	76.373 at 1,000 °C
T	–6.258 at –270 °C	20.872 at 400 °C
S	–0.236 at –50 °C	18.693 at 1,768 °C
R	–0.226 at –50 °C	21.101 at 1,768 °C
B	–0.000 at 0°C	13.820 at 1,820 °C

* Source of information is *NIST Monograph 175: Temperature-Electromotive Force Reference Functions and Tables for the Letter-Designated Thermocouple Types Based on the ITS-90*, National Institute of Standards and Technology, 1993.

** All temperatures are the difference between the measuring end and the cold junction, or AMUX-64T screw terminals in this case.

Linearizing the Data

Thermocouple output voltages are highly nonlinear. The *Seebeck coefficient*, or voltage change per degree of temperature change, can vary by a factor of three or more over the operating temperature range of some thermocouples. For this reason, the temperature from thermocouple voltages must either be approximated by often complex polynomials or matched against a look-up table. The polynomial approach is easier to use, but it trades measurement time for memory usage. The polynomials are in the following form:

$$T = a_0 + a_1x + a_2x^2 + \dots + a_nx^n$$

where x is the thermocouple voltage in *volts*, T is the temperature difference between the measuring end and the AMUX-64T screw terminals in degrees Celsius, and a_0 through a_n are coefficients that are specific to each thermocouple type. To speed computation time, a polynomial should be

computed in nested form. Consider the following fourth order polynomial:

$$T = a_0 + a_1x + a_2x^2 + a_3x^3 + a_4x^4$$

If this polynomial is evaluated as it is written, several extra multiplications will be performed to raise x to the various powers. If the polynomial is instead written as follows:

$$T = a_0 + x(a_1 + x(a_2 + x(a_3 + xa_4)))$$

and evaluated this way, no powers are computed, and execution proceeds much faster. Table 3-3 lists the National Institute of Standards and Technology (NIST) polynomial coefficients for several popular thermocouples.

Table 3-3. NIST Polynomial Coefficients

Type	E	E	J	J	T	T
Temp. Range	-200 °C to 0 °C 0.0°3 C to -0.01 °C	0 °C to 1,000 °C ± 0.02 °C	-210 °C to 0 °C 0.0.3 °C to -0.05 °C	0 °C to 760 °C ± 0.04 °C	-200 °C to 0 °C 0.04 °C to -0.02 °C	0 °C to 400 °C ± 0.03 °C
c ₀	0.0000000	0.0000000	0.0000000	0.0000000	0.0000000	0.0000000
c ₁	1.6977288E - 2	1.7057035E - 2	1.9528268E - 2	1.978425E - 2	2.5949192E - 2	2.592800E - 2
c ₂	-4.3514970E - 7	-2.3301759E - 7	-1.2286185E - 6	-2.001204E - 7	-2.1316967E - 7	-7.602961E - 7
c ₃	-1.5859697E - 10	6.5435585E - 12	-1.0752178E - 9	1.036969E - 11	7.9018692E - 10	4.637791E - 11
c ₄	-9.2502871E - 14	-7.3562749E - 17	-5.9086933E - 13	-2.549687E - 16	4.2527777E - 13	-2.165394E - 15
c ₅	-2.6084314E - 17	-1.7896001E - 21	-1.7256713E - 16	3.585153E - 21	1.3304473E - 16	6.048144E - 20
c ₆	-4.1360199E - 21	8.4036165E - 26	-2.8131513E - 20	-5.344285E - 26	2.0241446E - 20	-7.293422E - 25
c ₇	-3.4034030E - 25	-1.3735879E - 30	-2.3963370E - 24	5.099890E - 31	1.2668171E - 24	
c ₈	-1.1564890E - 29	1.0629823E - 35	-8.3823321E - 29			
c ₉		-3.2447087E - 41				
	R	R	S	S	K	K
	-50 °C to 250 °C ±0.02 °C	250 °C to 1,200 °C ±0.005 °C	-50 °C to 250 °C ±0.02 °C	250 °C to 1,200 °C ±0.01 °C	-200 °C to 0 °C 0.04 °C to -0.02 °C	0 °C to 500 °C 0.04 °C to -0.05 °C
c ₀	0.0000000	1.334584505E + 1	0.00000000	1.291507177E + 1	0.0000000	0.0000000
c ₁	1.8891380E - 1	1.472644573E - 1	1.84949460E - 1	1.466298863E - 1	2.5173462E - 2	2.508355E - 2
c ₂	-9.3835290E - 5	-1.844024844E - 5	-8.00504062E - 5	-1.534713402E - 5	-1.1662878E - 6	7.860106E - 8
c ₃	1.3068619E - 7	4.031129726E - 9	1.02237430E - 7	3.145945973E - 9	-1.0833638E - 9	-2.503131E - 10
c ₄	-2.2703580E - 10	-6.249428360E - 13	-1.52248592E - 10	-4.163257839E - 13	-8.9773540E - 13	8.315270E - 14
c ₅	3.5145659E - 13	6.468412046E - 17	1.88821343E - 13	3.187963771E - 17	-3.7342377E - 16	-1.228034E - 17
c ₆	-3.8953900E - 16	-4.458750426E - 21	-1.59085941E - 16	-1.29163750E - 21	-8.6632643E - 20	9.804036E - 22
c ₇	2.8239471E - 19	1.994710149E - 25	8.23027880E - 20	2.183475087E - 26	-1.0450598E - 23	-4.413030E - 26
c ₈	-1.2607281E - 22	-5.313401790E - 30	-2.34181944E - 23	-1.447379511E - 31	-5.1920577E - 28	1.057734E - 30
c ₉	3.1353611E - 26	6.481976217E - 35	2.79786260E - 27	8.211272125E - 36		-1.052755E - 35
c ₁₀	-3.3187769E - 30					

These polynomials are accurate only within the temperature ranges specified. Also, all terms must be included to achieve the specified accuracy.

To avoid the long computation time required for these high-order polynomials, the operating range of a thermocouple can be subdivided into several smaller ranges. Each of the smaller ranges can then be approximated by a much lower order polynomial (i.e., third or fourth degree). Further examples of polynomials, including lower order polynomials for subdivided temperature ranges, can be found in *NIST Monograph 175: Temperature-Electromotive Force Reference Functions and Tables for the Letter-Designated Thermocouple Types Based on the ITS-90*.

Differential Measurements

Connect the temperature sensor to channel 0 and channel 32 (differential channel 0) by configuring jumper W1 as shown in Table 2-2, *Temperature Sensor Selection*. Connect the thermocouples to the appropriate pairs of input channel screw terminals (for example, CH1 and CH33, CH2 and CH34, and so on). Notice that some thermocouples, such as those from Omega Engineering, have red insulation on the *negative* terminal. Check with the vendor to determine the output polarity of any particular thermocouple. Since thermocouples are floating signal sources, you must attach a bias return resistor between the negative channel and ground, which is connected to the MIO board AIGND (analog input ground) pin. The signal path of each channel has component locations for such resistors. Refer to the *Connecting Nonreferenced or Floating Signal Sources* section of Chapter 4, *Signal Conditioning*, for the resistor component locations. For more information about signal sources and their connections, see the configuration chapter of the user manual that came with your MIO board.

An Example of Using Thermocouples (Differential or Single-Ended)

For this example, assume that a J-type thermocouple is connected to differential channel 1 and is being used to measure a high-pressure boiler system. The maximum temperature that can be reached is 300 °C. Before taking readings, it is necessary that you configure the MIO board for the maximum resolution possible. A thermocouple table shows that the output voltage will never exceed 16 to 17 mV (recall that the exact voltage measured is a function of the AMUX-64T temperature as well as the temperature being measured). Therefore, you could select either a ± 5 V input range with a gain of 100 (± 50 mV maximum signal) or a ± 10 V input range with a gain of 500 (± 20 mV maximum signal). In this case, the ± 10 V

input range with a gain of 500 gives the best resolution. Set the jumpers on the MIO board for differential input, ± 10 V input range.

**Note**

Set jumper W1 on the AMUX-64T to select the temperature sensor, and connect the thermocouple to CH1 and CH33. Connect a resistor between CH33 and GND for the bias current return path.

Set the jumpers on the MIO board for single-ended input, ± 10 V input range. Set jumper W1 on the AMUX-64T to select the temperature sensor, and connect the thermocouple to CH1.

Two software compensation procedures for this example follow. Procedure 1 is more accurate, but procedure 2 is faster and requires less computation.

Procedure 1

1. Read the voltage from the temperature sensor (channel 0). If you are using NI-DAQ, you can use the `AI_Read` and `AI_Scale` functions to do the reading. This voltage is $10 \text{ mV}/^\circ\text{C}$, so the gain should be either 1 or 10 (10 for the best resolution). Multiply the voltage by 100 to get the AMUX-64T temperature in degrees Celsius. For example, if the reading is 0.25 V, the AMUX-64T is at 25°C .
2. Translate the reading into the voltage for a J-type thermocouple at that temperature using either a look-up table or an NIST polynomial. Notice that the polynomials required here are the *inverses* of those given in Table 3-3. For your reading of 25°C , you would have 1.277 mV.
3. Read the voltages on any thermocouple channels. If you are using NI-DAQ, you can use the `AI_Read` and `AI_Scale` functions to read each channel. For the example given, assume that you get a reading of 9.39 mV on channel 1.
4. Add the voltage from step 2 to the voltage measured in step 3. You then have:

$$1.277 + 9.39 = 10.667 \text{ mV}$$
5. Translate the result into a temperature using either a look-up table or a polynomial such as one from Table 3-3. For example, assume that the reading from the J-type thermocouple is 10.667 mV. By applying the third formula in the *Linearizing the Data* section and using the coefficients from Table 3-3, you can calculate that the temperature is 198°C .

Procedure 2

1. Read the voltage from the temperature sensor (channel 0). If you are using NI-DAQ, you can use the `AI_Read` and `AI_Scale` functions to do the reading. This voltage is 10 mV/°C, so the gain should be either 1 or 10 (10 for the best resolution). Multiply the voltage by 100 to get the AMUX-64T temperature in degrees Celsius. For example, if the reading is 0.25 V, the AMUX-64T is at 25 °C.
2. Read the voltages on any thermocouple channels. If you are using NI-DAQ, you can use the `AI_Read` and `AI_Scale` functions to read each channel, or you can use the `SCAN` functions to scan all the channels at once. If you use the `SCAN` functions, use a sample interval of 100 µs between channels. For the example given, the gain is at 500 for channel 1. Other thermocouple types may require other gains.
3. Translate the reading into a temperature using either a look-up table or a polynomial such as one from Table 3-3. For example, when reading 9.39 mV from a type J thermocouple, the temperature is 175 °C.
4. Add the cold-junction temperature from step 1 to the temperature obtained in the previous step. This result is the temperature at the measuring end of the thermocouple. For the example given, the temperature is $175\text{ °C} + 25\text{ °C} = 200\text{ °C}$.

Comments

Procedure 1 is more accurate, but it requires two temperature-voltage conversions. Procedure 2 is faster, but introduces an error of 2 °C. To determine if the error from procedure 2 is acceptable or not in your application, you can work through some examples both ways. Use a thermocouple reference table and consider voltages and temperatures close to those in your application.

Single-Ended Measurement

Connect the temperature sensor to channels 0 and 32 by configuring jumper W1 as shown in Table 2-2, *Temperature Sensor Selection*. Connect the positive leads of the thermocouples to any AMUX-64T input channels except CH0 and CH32. Connect the negative leads to GND. Notice that some thermocouples, such as those from Omega Engineering, have red insulation on the *negative* terminal. Check with the vendor to determine the output polarity of any particular thermocouple. Configure the MIO board for ground-referenced, single-ended inputs. For more information about signal sources and their connections, see the *Signal Connections* chapter of the user manual that came with your MIO board.

Using More Than One AMUX-64T

Two cold-junction compensation options are possible when thermocouples are being used with two or more AMUX-64T boards connected to one MIO board. If all AMUX-64T boards are at approximately the same temperature, only one needs to have the temperature sensor connected to channels 0 and 32. These two channels on the other boards are then free for more thermocouples. If the AMUX-64T boards are not at approximately the same temperature, you should use the temperature sensor on each AMUX-64T. Using the temperature sensors on each board reduces the chance of cold-junction compensation error, but it does increase software overhead and reduce the number of channels available for general use.

If you use two AMUX-64T boards, the sensors will appear at channel 0 for board A and channel 64 for board B. If you use four AMUX-64T boards, the sensors will appear at channel 0 for board A, channel 64 for board B, channel 128 for board C, and channel 192 for board D (see the [Single-Board and Multiple-Board Configurations](#) section in Chapter 2, [Configuration and Installation](#)).

Sources of Error

There are several major sources of error when making thermocouple measurements with the AMUX-64T and an MIO board. These sources of error are compensation, linearization, measurement, and thermocouple wire errors.

Compensation error can arise from two sources, inaccuracy of the temperature sensor and temperature differences between the sensor and the screw terminals. The sensor on the AMUX-64T is specified to be accurate to ± 1 °C. You can minimize temperature differences between the sensor and the screw terminals by keeping the AMUX-64T away from drafts, heaters, warm equipment, and so on. Linearization error is a consequence of the fact that the polynomials are by nature approximations of the true thermocouple output. The linearization error is dependent on the degree of polynomial used. Table 3-3 lists the linearization errors for the NIST polynomials.

Measurement error is the result of inaccuracies in the MIO board. These include gain and offset errors. If the board is properly calibrated, the offset error should be zeroed out. The only remaining error is a gain error of $\pm 0.08\%$ of full range (see the MIO board specifications). If the input range is ± 10 V and the gain is 500, gain error will contribute 0.0008×20 mV, or 16 μ V of error. If the Seebeck coefficient of a thermocouple is 32 μ V/ \pm C, this measurement error will add 0.5 °C of uncertainty to the measurement.

For best results, use a well-calibrated MIO board so that you can ignore offsets.

You can eliminate offset error, however, by grounding one channel on the AMUX-64T and measuring it. This value is the offset of the MIO board, and it can then be subtracted in software from all other readings. For the best results, you should use an average of many readings (about 100 or so). When you take these measures, typical accuracies are about ± 2 °C.

Finally, thermocouple wire error is caused by inhomogeneities in the thermocouple manufacturing process. These errors vary widely depending on the thermocouple type and even the gauge of wire used, but a value of ± 2 °C is typical. For more information on thermocouple wire errors and more specific data, see Application Note 043, *Measuring Temperature with Thermocouples*.

Thermocouple Measurement Accuracies

Table 3-4 lists the expected thermocouple accuracies in degrees Celsius, subject to the following conditions:

- The MIO board must be correctly calibrated.
- The temperature of the screw terminals equals the temperature of the board (no gradients on the board).

The uncertainties listed apply at either 0 °C (Type J, K, E, T) or 600 °C (Type S, R). The linearization errors of the NIST polynomials in Table 3-2, measurement error of a calibrated MIO board, and the ± 1 °C cold-junction sensor error are included. Thermocouple wire error is neglected because of dependence on several factors as listed above. Finally, these uncertainties are for the gains listed with a ± 10 V input range.

Table 3-4. Thermocouple Measurement Accuracies

Gain	Type					
	J	K	E	T	S	R
100	± 2.7 °C	± 3.7 °C	± 2.9 °C	± 3.6 °C	± 9.8 °C	± 8.5 °C
500	± 1.4 °C	± 2.1 °C	± 1.8 °C	± 1.9 °C	± 3.6 °C	± 2.9 °C

Other Connection Considerations

Refer to the sections titled *Analog Input Signal Connections* and *Cabling and Field Wiring* in the *Signal Connections* chapter of the user manual that came with your MIO board for additional signal connection information.

Signal Conditioning

This chapter discusses signal conditioning and describes how to build systems such as filters and attenuators for passive analog input signal conditioning.

Analog Input

Each differential analog input has seven open positions for signal conditioning components. Six of these positions are designated as resistors, and one is designated as a capacitor. The board is shipped with jumpers in two positions for each input. The equivalent circuit of one input is shown in Figure 4-1. You can use the board when the MIO board is configured for both 16 single-ended inputs and eight differential inputs. For thermocouple and other low-level applications, you can obtain best results when using differential inputs. For specific applications illustrating signal conditioning with both single-ended and differential inputs, refer to [Application Notes](#) later in this chapter.

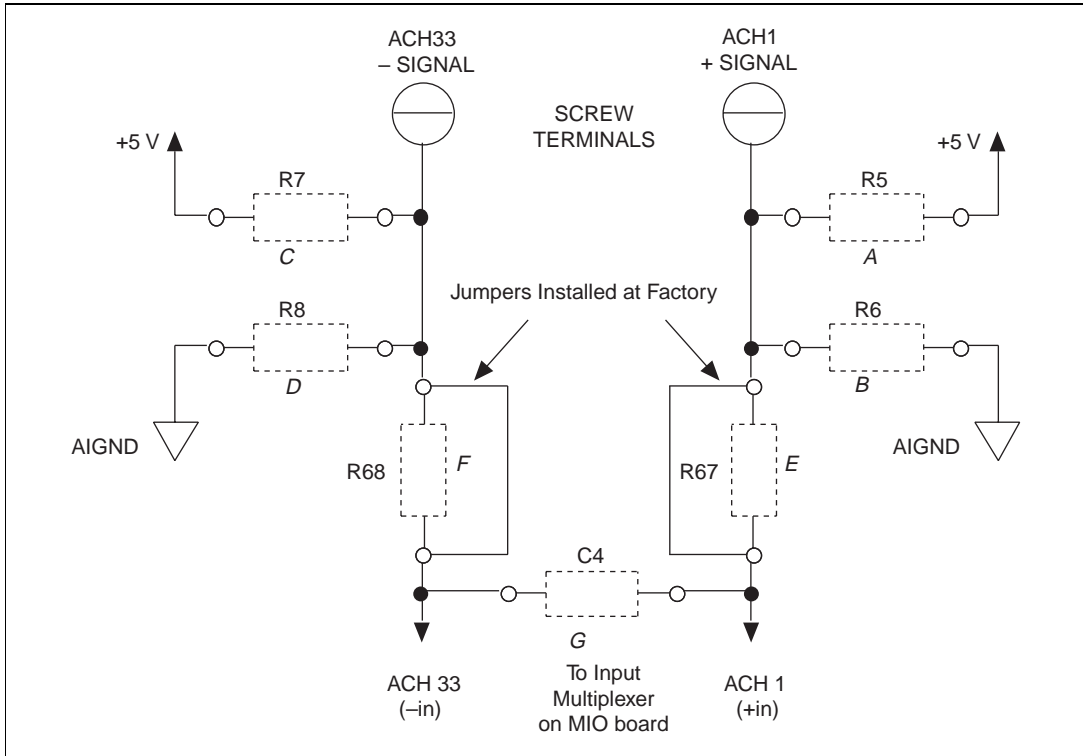

Figure 4-1. Onboard Equivalent Circuit

The components are numbered differently for each channel. Table 4-1 lists the components in each channel and their correspondence to the circuit shown in Figure 4-1.

Table 4-1. Component Positions in Each Channel

Channel		(Positions in Figure 4-1)						
Differential	Single-Channel	A	B	C	D	E	F	G
0	(0, 32)	R1	R2	R3	R4	R65	R66	C3
1	(1, 33)	R5	R6	R7	R8	R67	R68	C4
2	(2, 34)	R9	R10	R11	R12	R69	R70	C5
3	(3, 35)	R13	R14	R15	R16	R71	R72	C6
4	(4, 36)	R17	R18	R19	R20	R73	R74	C7
5	(5, 37)	R21	R22	R23	R24	R75	R76	C8

Table 4-1. Component Positions in Each Channel (Continued)

Channel		(Positions in Figure 4-1)						
Differential	Single-Channel	A	B	C	D	E	F	G
6	(6, 38)	R25	R26	R27	R28	R77	R78	C9
7	(7, 39)	R29	R30	R31	R32	R79	R80	C10
8	(8, 40)	R33	R34	R35	R36	R81	R82	C11
9	(9, 41)	R37	R38	R39	R40	R83	R84	C12
10	(10, 42)	R41	R42	R43	R44	R85	R86	C13
11	(11, 43)	R45	R46	R47	R48	R87	R88	C14
12	(12, 44)	R49	R50	R51	R52	R89	R90	C15
13	(13, 45)	R53	R54	R55	R56	R91	R92	C16
14	(14, 46)	R57	R58	R59	R60	R93	R94	C17
15	(15, 47)	R61	R62	R63	R64	R95	R96	C18
16	(16, 48)	R129	R130	R131	R132	R97	R98	C37
17	(17, 49)	R133	R134	R135	R136	R99	R100	C38
18	(18, 50)	R137	R138	R139	R140	R101	R102	C39
19	(19, 51)	R141	R142	R143	R144	R103	R104	C40
20	(20, 52)	R145	R146	R147	R148	R105	R106	C41
21	(21, 53)	R149	R150	R151	R152	R107	R108	C42
22	(22, 54)	R153	R154	R155	R156	R109	R110	C43
23	(23, 55)	R157	R158	R159	R160	R111	R112	C44
24	(24, 56)	R161	R162	R163	R164	R113	R114	C45
25	(25, 57)	R165	R166	R167	R168	R115	R116	C46
26	(26, 58)	R169	R170	R171	R172	R117	R118	C47
27	(27, 59)	R173	R174	R175	R176	R119	R120	C48
28	(28, 60)	R177	R178	R179	R180	R121	R122	C49
29	(29, 61)	R181	R182	R183	R184	R123	R124	C50

Table 4-1. Component Positions in Each Channel (Continued)

Channel		(Positions in Figure 4-1)						
Differential	Single-Channel	A	B	C	D	E	F	G
30	(30, 62)	R185	R186	R187	R188	R125	R126	C51
31	(31, 63)	R189	R190	R191	R192	R127	R128	C52

When the board is shipped, jumpers are inserted in the *E* and *F* positions of the input network (see Figure 4-1). You can easily remove these jumpers to build analog input signal conditioning circuits. Several applications showing the use of these open component positions are discussed in the next section, *Application Notes*.

Application Notes

The open component positions on the AMUX-64T board make adding signal conditioning components to the analog input signals easier. Several applications are covered in this section, including filtering and attenuation.

The figures in this section give examples on a specific input channel. If you want to install the circuit on a different channel, consult Table 4-1 to determine the equivalent component positions for the other channels.

Soldering and Desoldering on the AMUX-64T Board

The following applications require you to make modifications to the printed circuit board, usually in the form of removing jumpers and adding components. The AMUX-64T board is shipped with wire jumpers in the *E* and *F* positions (see Table 4-1 and Figure 4-1).

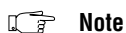

Note

Remove the plastic insulator on the bottom of the AMUX-64T before removing wire jumpers or adding components to the board. To remove the insulator, unscrew the standoff from the top of the board; the insulator and standoff should fall off. Replace the insulator and standoff after completing your modifications to the board.

Use a low-wattage soldering iron (20 to 30 W) when soldering to the board. To desolder on the AMUX-64T, use vacuum-type tools for best results. Use care when desoldering to avoid damaging component pads. You should use only rosin-core electronic-grade solder. Acid-core solder damages the printed circuit board and components.

Channel Configurations

You can configure the analog input channels of an MIO DAQ board for one of three input modes: differential input, referenced single-ended input, or nonreferenced single-ended. These modes may be referred to as DIFF, RSE, and NRSE input modes, respectively.

As described in Chapter 2, *Configuration and Installation*, of your MIO user manual, the input configuration of the MIO board depends on the type of signal source. There are two types of signal sources: nonreferenced or floating signals and ground-referenced signals. To measure floating signal sources, configure the MIO board for referenced single-ended input or differential input with bias resistors. To measure ground-referenced signal sources, configure the MIO board for non-referenced single-ended input or differential input. Both types of signal sources and the recommended methods for MIO board connection are discussed as follows.

Connecting Nonreferenced or Floating Signal Sources

A floating signal source is a signal source that is not connected in any way to the building ground system, but has an isolated ground-reference point. If an instrument or device has an isolated output, that instrument or device falls into the floating signal source category. Some examples of floating signal sources are outputs for the following: thermocouples, transformers, battery-powered devices, optical isolators, and isolation amplifiers. You must tie the ground reference of a floating source to the ground of the DAQ board to establish a local or onboard reference for the signal.

Differential Inputs

To provide a return path for the instrumentation amplifier bias currents, floating sources must have a resistor connected to AIGND on one input if the signal is DC-coupled, or both inputs if the signal is AC-coupled. For more detailed information on connections to floating signal sources and differential inputs, refer to the configuration chapter in the user manual that came with your MIO board.

You can install these bias resistors in positions B and D (Table 4-1 and Figure 4-1) of the AMUX-64T board. Figure 4-2 shows both the schematic and the component placement for a single 100 k Ω bias return resistor on the negative input from a floating source connected to channel 1 (the D position in Table 4-1). You can build additional signal conditioning circuitry, such as filters and attenuators (described in *Building Lowpass Filters*, *Building Highpass Filters*, and *Building Attenuators (Voltage Dividers)* later in this chapter), in the open component positions.

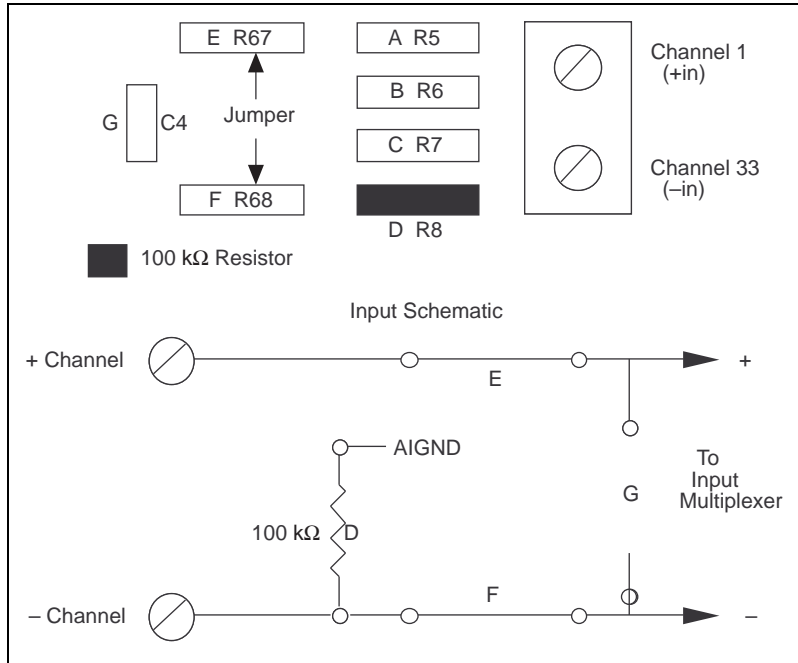

Figure 4-2. Bias Return Resistor for DC-Coupled Floating Source on Channel 1

Single-Ended Inputs

When measuring floating signal sources, you should configure the MIO board to supply a ground reference. Therefore, you should configure the MIO board for referenced single-ended input. In this configuration, the negative input of the MIO board instrumentation amplifier is tied to the analog ground. Therefore, you should use the AMUX-64T board in its factory configuration. In the factory configuration, jumpers are in the two series positions, *E* and *F* (see Table 4-1). In this configuration, you should tie all of the signal grounds to AIGND. You can build signal conditioning circuitry such as filters and attenuators (described in *Building Lowpass Filters*, *Building Highpass Filters*, and *Building Attenuators (Voltage Dividers)* later in this chapter) in the open component positions.

Connecting Ground-Referenced Signal Sources

A grounded signal source is connected in some way to the building system ground; therefore, the signal source is already connected to a common ground point with respect to the DAQ board (assuming the host computer is plugged into the same power system). Nonisolated outputs of instruments and devices that plug into the building power system fall into this category.

Differential Inputs

If the MIO DAQ board is configured for differential inputs, ground-referenced signal sources connected to the AMUX-64T board need no special components added to the AMUX-64T board. You can leave the inputs of the AMUX-64T board in the factory-original condition, that is, with only jumpers in the two series positions, *E* and *F* (see Table 4-1). You can build signal conditioning circuitry, such as filters and attenuators (described in *Building Lowpass Filters*, *Building Highpass Filters*, and *Building Attenuators (Voltage Dividers)* later in this chapter), in the open component positions.

Single-Ended Inputs

When measuring ground-referenced signals, the external signal supplies its own reference ground point and the MIO board should not supply one. Therefore, you should configure the MIO board for nonreferenced single-ended input mode. In this configuration, you should tie all of the signal grounds to AISENSE, which connects to the negative input of the instrumentation amplifier on the MIO board. You can leave the inputs of the AMUX-64T board in the factory-default condition, that is, with jumpers in the series position (*E* or *F*, depending on the channel). You should not use the open positions that connect the input to AIGND, *B* and *D* (see Table 4-1 and Figure 4-1) in this configuration. Therefore, you should not build signal conditioning circuitry requiring a ground reference in the open component positions. Referencing the signal to AIGND can cause inaccurate measurements resulting from an incorrect ground reference.



Caution

NEVER connect a signal to screw terminals CH0–CH63 that violates their overvoltage protection limits. When the AMUX-64T is powered on, the screw terminals CH0–CH63 overvoltage protection is ± 35 V; when the AMUX-64T is powered off, overvoltage protection is ± 20 V.

Building Lowpass Filters

You can easily install simple resistance-capacitance (RC) lowpass filters in the AMUX-64T board on any differential input channel. The filters are useful for accurate measurement and noise rejection. By substituting resistance and capacitance values into the following equation (hereafter referred to as equation 4-1), you can calculate a simple, one-pole RC filter to have a -3 dB point (f_c or cutoff frequency):

$$f_c = \frac{1}{(2\pi RC)} \quad (4-1)$$

The frequency response rolls off at a rate of -20 dB per decade of increase thereafter. A Bode plot of the amplitude versus normalized frequency is shown in Figure 4-3.

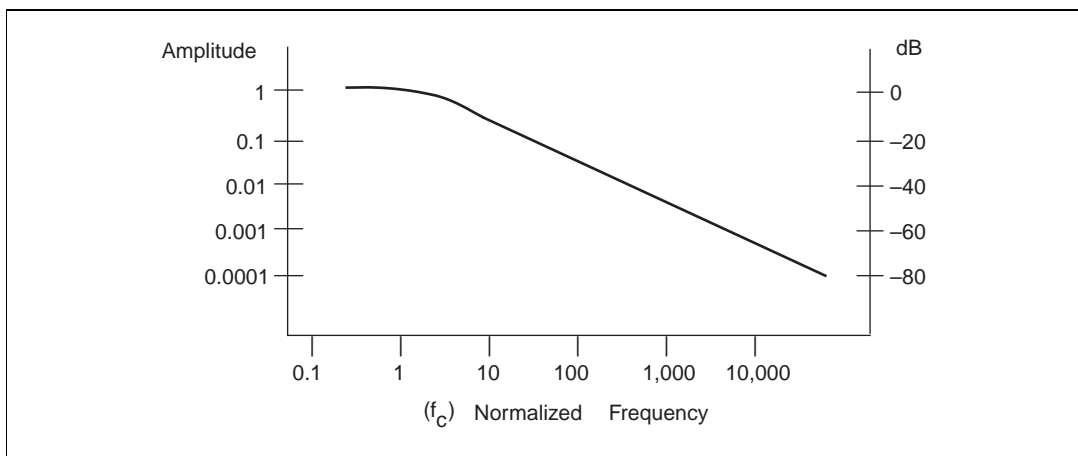

Figure 4-3. Normalized Frequency Response of Lowpass Filter

When measuring low-frequency signals (about 4 Hz), if you have 400 Hz noise on your inputs, you can add a lowpass filter with a cutoff frequency of 4 Hz. The 400 Hz noise then attenuates by 40 dB. Notice that your 4 Hz signal also attenuates, but by only 3 dB. Do not neglect any potential attenuation of signals of interest by this low-order filter.

You must also choose the filter component values. You can select the resistance or the capacitance arbitrarily; one value determines the other. Picking the capacitor first and letting its value determine the resistance required is preferable because more standard resistor values are available.

If a capacitance of $1\ \mu\text{F}$ is available, the resistance is (by substitution into the equation) $39,789\ \Omega$, or about $39.8\ \text{k}\Omega$. This resistance must be divided by two to get the resistor value on each input of a differential channel. Therefore, in this example, each input has a $19.89\ \text{k}\Omega$ resistor (or closest standard value) in its series positions, *E* and *F*.

The closest standard 5% tolerance resistors are $20\ \text{k}\Omega$. The closest standard 0.5% resistors are $19.8\ \text{k}\Omega$. National Instruments recommends using 1% or better tolerance resistors in this application because differences between the resistor values degrade the common-mode rejection ratio. Figure 4-4 shows both the schematic and the component placement for a 4 Hz lowpass filter placed on differential input channel 1. If the input signal source is floating, you must place a bias return resistor in the *D* position (*R8* in this case).

Do not install RC lowpass filters on the AMUX-64T board open component locations when the MIO board is configured for single-ended inputs.

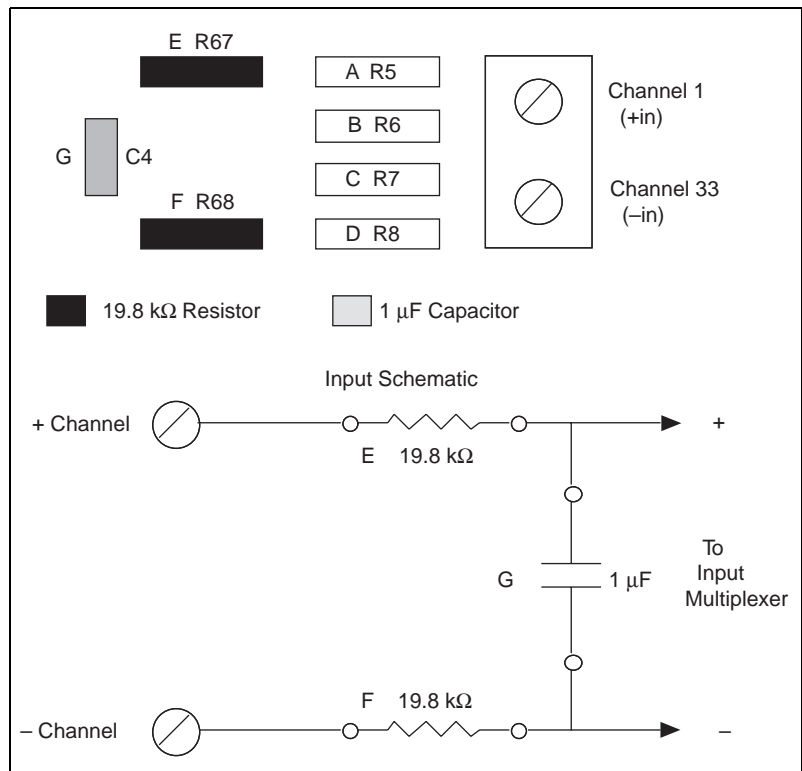

Figure 4-4. Lowpass Filter on Differential Channel 1

Building Highpass Filters

You can easily install simple RC highpass filters in the AMUX-64T board on any differential input channel. The filters are useful for accurate high-frequency measurement and low-frequency noise rejection. By substituting resistance and capacitance values into the following equation, (hereafter referred to as equation 4-2), you can calculate a simple, one-pole R-C filter to have a -3 dB point (f_c or cutoff frequency):

$$f_c = \frac{1}{(2\pi RC)} \quad (4-2)$$

The frequency response rolls off at a rate of -20 dB per decade decrease thereafter. A Bode plot of the amplitude versus normalized frequency is shown in Figure 4-5.

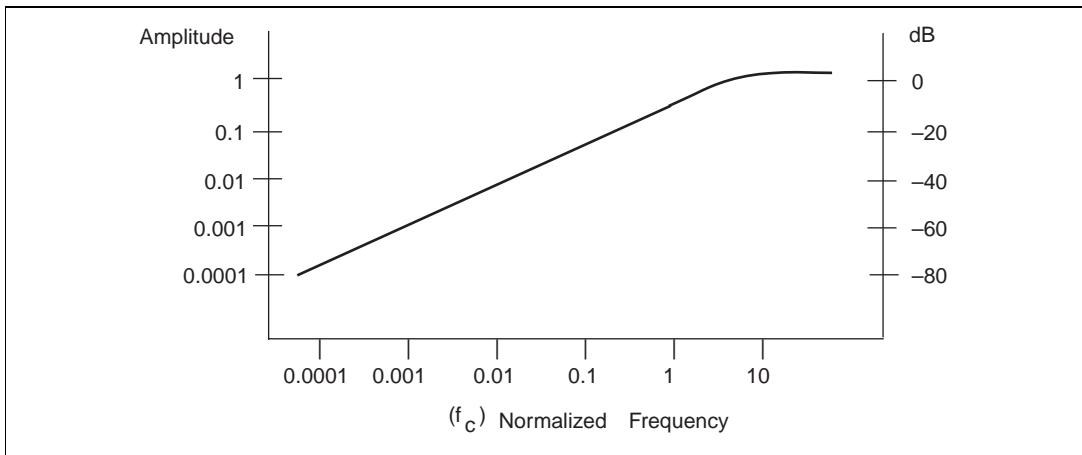

Figure 4-5. Normalized Frequency Response of Highpass Filter

When measuring high-frequency signals (about 50 kHz), if you have 50 Hz noise on your inputs, you can add a highpass filter with a cutoff frequency of 50 kHz. The 50 Hz noise then attenuates by 60 dB. Notice that your 50 kHz signal also attenuates, but by only 3 dB. Do not neglect any potential attenuation of signals of interest if you add a low-order filter.

You must also choose the filter component values. You can select the resistance or the capacitance arbitrarily; one value determines the other. Picking the capacitor first and letting its value determine the resistance required is preferable because more standard resistor values are available.

The filter circuit has one series capacitor on each input of the differential channel. Because the two capacitors are in series, the capacitance value that must be substituted into equation 4-2 is the series capacitance of the two capacitors in series. For two capacitors in series, the net capacitance is the reciprocal of the sum of the reciprocals of the two capacitances. For example, two 0.001 μF capacitors in series have a net capacitance of 0.0005 μF . The two capacitors should be the same value, or the common-mode rejection is degraded. If capacitors of 0.001 μF are available, the resistance is (by substitution into equation 4-2) 6,366 Ω , or about 6.4 $\text{k}\Omega$. Therefore, in this example, the input channel has a 6.37 $\text{k}\Omega$ resistor (or closest standard value) in its capacitor position, G .

The closest standard 5% tolerance resistors are 6.2 $\text{k}\Omega$. The closest standard 1% resistors are 6.34 $\text{k}\Omega$. Figure 4-6 shows both the schematic and the component placement for a 50 kHz highpass filter placed on differential input channel 1. If the input signal source is floating, you must place a bias return resistor in the D position ($R8$ in this case).

**Note**

Highpass filters generally exhibit poorer common-mode rejection characteristics than lowpass filters because capacitors are in the series input paths. Capacitors have poorer tolerances than resistors, and matching of the input impedances is crucial for good common-mode rejection.

Do not install RC highpass filters on the AMUX-64T board open component locations when the MIO board is configured for single-ended inputs.

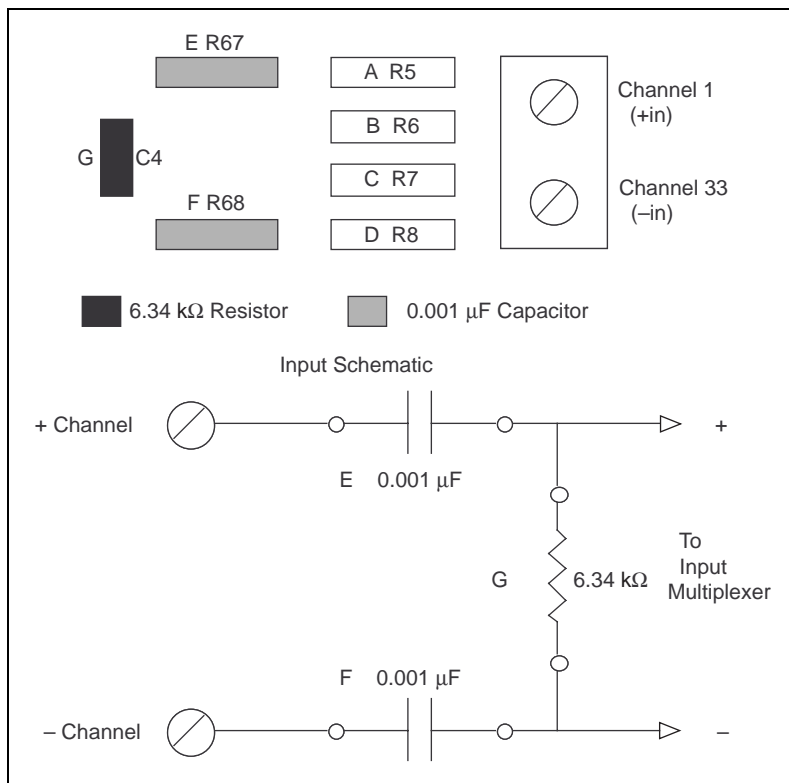

Figure 4-6. Highpass Filter on Differential Channel 1

Building Attenuators (Voltage Dividers)

You can connect attenuators (voltage dividers) to the analog inputs of the AMUX-64T board when the inputs from its DAQ board are in differential mode. Do not install voltage dividers on the AMUX-64T board open component locations when the MIO board is configured for single-ended inputs. You can use attenuators to reduce a signal that is outside the normal input range of the DAQ board (± 10 V max).



Warning *The AMUX-64T board is not designed for any input voltages greater than 42 V, even if a user-installed voltage divider reduces the voltage to within the input range of the DAQ board. Input voltages greater than 42 V can result in damage to the AMUX-64T board, any and all boards connected to it, and the host computer. Overvoltage can also cause an electric shock hazard for the operator. National Instruments is NOT liable for damage or injury resulting from such misuse.*

A three-resistor circuit for attenuating voltages at the differential inputs of the AMUX-64T board is shown in Figure 4-7. The figure also shows the placement of the resistors on the open component positions for differential Channel 1. The gain G of this attenuator is given by the following equation:

$$G = \frac{R_G}{(R_E + R_F + R_G)} \quad (4-3)$$

Therefore, the input to the MIO board (V_{MIO}) is

$$V_{MIO} = V_{SC} \cdot G$$

where V_{SC} is the voltage applied to the screw terminals of the AMUX-64T. The accuracy of this gain equation depends on the tolerances of the resistors used.

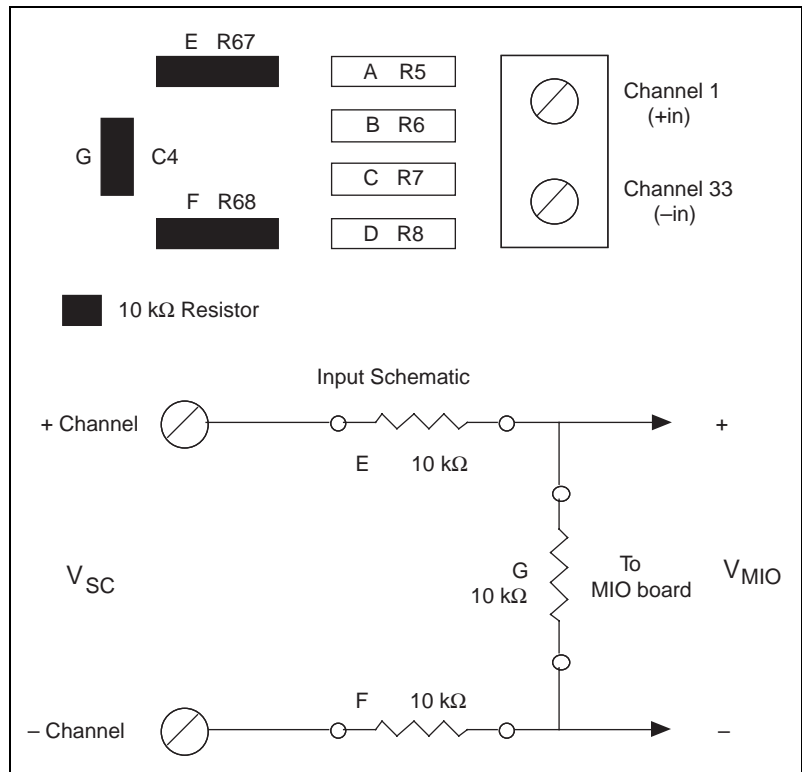

Figure 4-7. Attenuator for Use with Differential Inputs

Example:

Using the values in Figure 4-7,

$$G = \frac{10 \text{ k}\Omega}{(10 \text{ k}\Omega + 10 \text{ k}\Omega + 10 \text{ k}\Omega)} = \frac{1}{3}$$

Therefore,

$$V_{MIO} = \frac{1}{3}V_{SC}$$

When the MIO board is configured for ± 10 V inputs, the board can acquire ± 30 V signals with this attenuator circuit.

Theory of Operation and Register-Level Programming

This chapter contains a functional overview of the AMUX-64T and explains the operation of each functional unit making up the AMUX-64T. This chapter also contains register-level programming information for the MIO board.

**Note**

If you plan to use a software package such as LabWindows, NI-DAQ, or LabVIEW with your MIO board, you need not read this chapter.

Functional Overview

Figure 5-1 shows the block diagram of the AMUX-64T. The AMUX-64T contains 16 CMOS four-to-one analog multiplexers for a total of 64 channels. Each analog multiplexer expands a single MIO analog input channel to four AMUX-64T analog input channels.

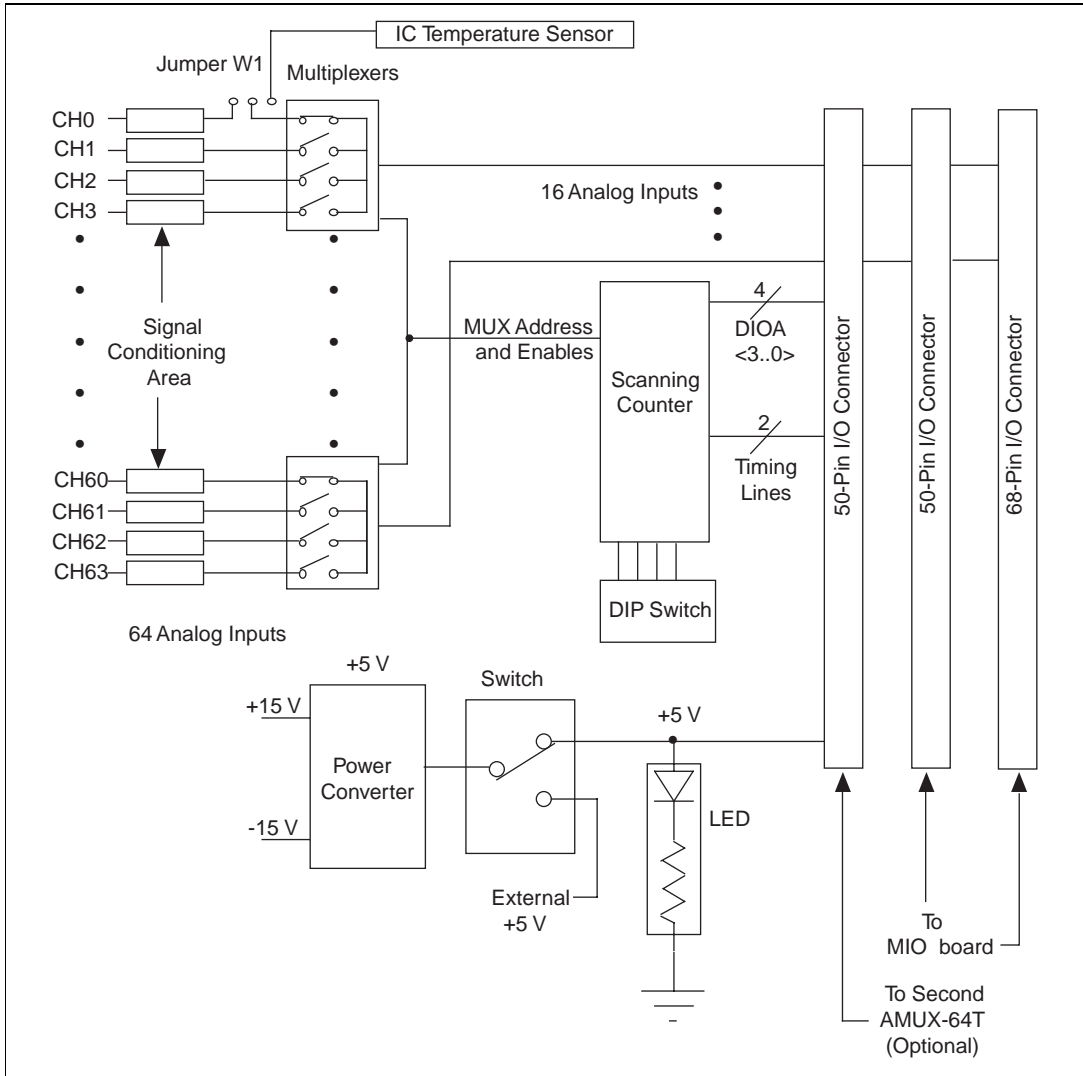

Figure 5-1. AMUX-64T Block Diagram

The AMUX-64T multiplexers are controlled by a 4-bit scanning counter that is loaded via the 4-bit digital I/O port A of the MIO board. The MIO signal EXTSTROBE* loads the value at digital I/O port A into the AMUX-64T scanning counter. The MIO signal SCANCLK, which is active during scanned data acquisition, switches the input channels automatically on the AMUX-64T after each A/D conversion.

The DIP switch attached to the scanning counter configures the AMUX-64T for one-board, two-board, or four-board operation. Individual AMUX-64T boards are selected depending on the higher-order two bits of the scanning counter.

The AMUX-64T contains an onboard switch to either power the AMUX-64T from the MIO board or to supply +5 V externally. From the +5 V power, an onboard DC-to-DC converter generates a ± 15 V source, which is used to power the multiplexers. The MIO board can supply enough +5 V power to drive up to four AMUX-64T boards except the MC-MIO-16, which can power only two boards.

How to Address AMUX-64T Analog Input Channels

A/D Conversions on a Single AMUX-64T Analog Input Channel

Before an AMUX-64T channel can be selected, digital I/O port A must be enabled as a digital output port. You can enable this port by setting the DOUTEN0 bit in the MIO Command Register 2 (this bit has different names depending on your MIO board). This bit needs to be set only once after initializing the MIO board.

The scanning counter is used to select individual multiplexer inputs and individual AMUX-64T boards. The bit assignment for the scanning counter and MIO board digital I/O port A is shown in Figure 5-2.

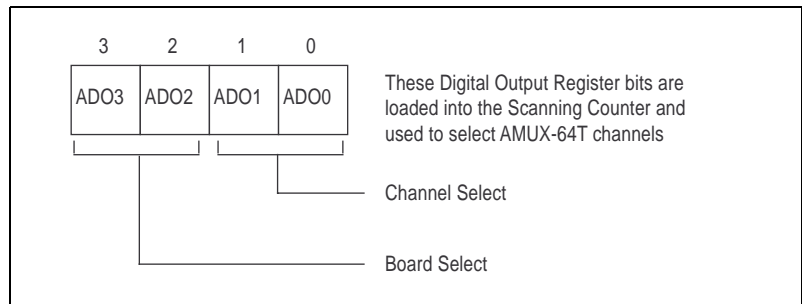

Figure 5-2. Scanning Counter Control Bits

Bits ADO0 and ADO1 address each four-to-one multiplexer on the AMUX-64T and work in combination with the MIO Mux-Gain Register (the Mux-Mem Register in the AT-MIO-16F-5) to select the analog input channel. An address map for selecting analog input channels on a single AMUX-64T is shown in Table 5-1.

Table 5-1. AMUX-64T Channel Selection

Channel Number	Mux-Gain Register MA<3..0>	Digital Port A Bits ADO<1..0>
0	0000	00
1	0000	01
2	0000	10
3	0000	11
4	0001	00
5	0001	01
6	0001	10
7	0001	11
—	—	—
—	—	—
28	0111	00
29	0111	01
30	0111	10
31	0111	11
32	1000	00
33	1000	01
34	1000	10
35	1000	11
—	—	—
—	—	—
60	1111	00
61	1111	01
62	1111	10
63	1111	11

Bits ADO2 and ADO3 select each individual AMUX-64T board in a multiple-board configuration. If you use only one AMUX-64T board, ADO2 and ADO3 are ignored. If you use two AMUX-64T boards, only ADO2 is used. An address map for the different channel groups is shown in Table 5-2.

Table 5-2. Multiple AMUX-64T Board Addressing

Digital Port A Bits ADO<3..2>	Board Selected	Channels Selected
00	A	0–63
01	B	64–127
10	C	128–191
11	D	192–255

Observe that channels on a single AMUX-64T are labeled 0 through 63. If you use more than one AMUX-64T board, however, channel numbering changes (see Table 5-2).

When you use four AMUX-64T boards with channel addresses ranging from 0 to 255, eight bits are required to address any single channel. This 8-bit address must be split and written to the Digital Output Register and the Mux-Gain Register (the Mux-Mem Register in the AT-MIO-16F-5). Figure 5-3 shows the mapping of the 8-bit channel address to the Digital Output and Mux-Gain Registers. To select a given channel, write the two least significant bits to bits ADO0 and ADO1 of digital I/O port A, the four middle bits to bits MA<3..0> of the Mux-Gain Register, and the two most significant bits to bits ADO3 and ADO2 of digital I/O port A. Notice that for differential operation, bit MA3, which corresponds to bit 5 of the channel address, becomes a don't care bit. This occurs because only eight multiplexers are used for differential operation.

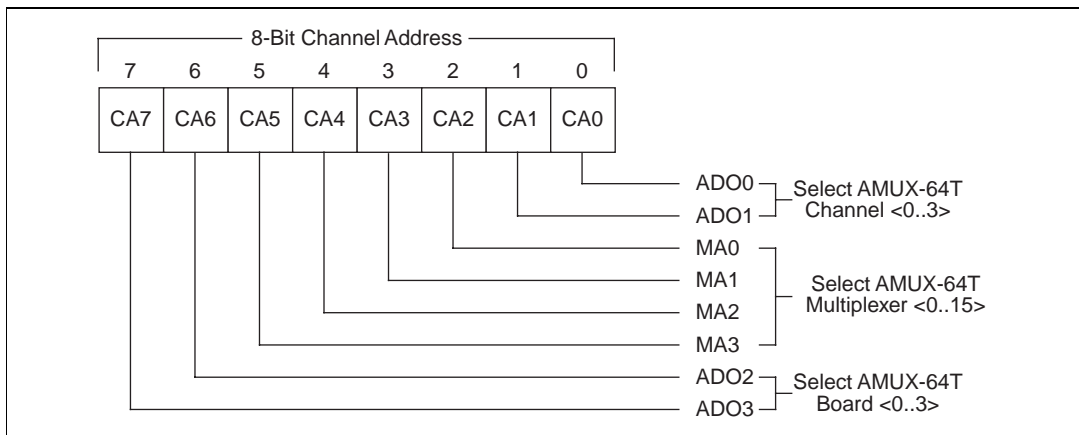

Figure 5-3. AMUX-64T Channel Address Mapping

To perform an A/D conversion on a single AMUX-64T channel, perform the following programming steps:

1. Select an analog input channel on the AMUX-64T by writing the appropriate channel address bits to digital I/O port A (bits 0 through 3 of the Digital Output Register).
2. Write to the External Strobe Register to load the channel address into the AMUX-64T scanning counter.
3. Write to the MA<3..0> bits in the Mux-Gain Register to select the four-to-one multiplexer on the AMUX-64T you want to address.

Now follow the normal procedure for performing a single A/D conversion or multiple A/D conversions on a single input channel of the MIO board with one exception—the bits MA<3..0> of the Mux-Gain Register must correspond to the middle four bits of your channel address shown in Figure 5-3.

Automatic Channel Scanning with the AMUX-64T

Automatic scanning of the AMUX-64T analog input channels is performed by the scanning counters on the AMUX-64T and the MIO board. Scanning operations on the MIO board are controlled by the mux-gain memory, which holds a sequence of multiplexer addresses. After each A/D conversion, the mux-gain memory switches to the next multiplexer input in the sequence. When the MIO board is used alone, a single-level multiplexer switches the 16 input channels to the analog-to-digital converter (ADC). A two-level multiplexer must be controlled when an AMUX-64T board is connected to the MIO board. The AMUX-64T switches 64 inputs down to 16 outputs, and the MIO board switches 16 inputs down to 1 output going to the ADC, as shown in Figure 5-4.

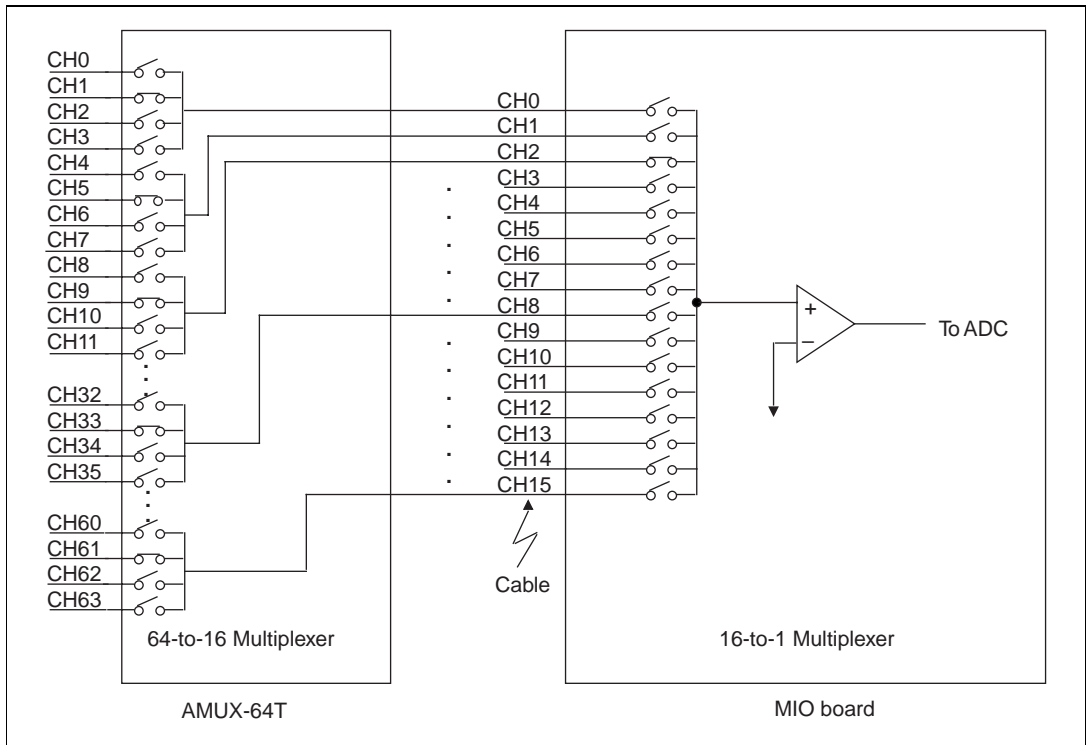

Figure 5-4. Two-Level Multiplexer Arrangement Showing Channel 9 Selected

When operating stand-alone, the MIO board selects a new input channel after each A/D conversion. A clock signal, SCANCLK, is generated by the MIO board and starts each A/D conversion on the rising edge of the signal. This clock also increments the onboard scanning counter. When a single AMUX-64T board is connected to the MIO board, four AMUX-64T input channels must be scanned for every MIO board channel. SCANCLK increments the AMUX-64T scanning counter on every A/D conversion, and Counter 1 on the MIO board must be used to divide the onboard scanning counter clock by four. The *Single-Board Configuration* section of Figure 5-5 shows the scanning order for the four AMUX-64T channels multiplexed to MIO board channel 0.

If two AMUX-64T boards are attached to the MIO board, eight AMUX-64T channels must be scanned for every MIO board input channel. For example, channels 0 through 3 on AMUX-64T board A and channels 64 through 67 on AMUX-64T board B are multiplexed together into MIO board channel 0. The *Two-Board Configuration* section of Figure 5-5 shows the order in which these eight AMUX-64T channels are scanned. Observe that the first four channels on board A are scanned first, followed by the first four channels on board B.

If four AMUX-64T boards are attached to the MIO board, 16 AMUX-64T channels must be scanned for every MIO board input channel. For example, channels 0 through 3 on AMUX-64T board A, channels 64 through 67 on AMUX-64T board B, channels 128 through 131 on AMUX-64T board C, and channels 192 through 195 on board D are multiplexed together into MIO board channel 0. The *Four-Board Configuration* section of Figure 5-5 shows the order in which these 16 AMUX-64T channels are scanned: the first four channels on board A are scanned first, followed by the first four channels on board B, the first four channels on board C, and finally the first four channels on board D.

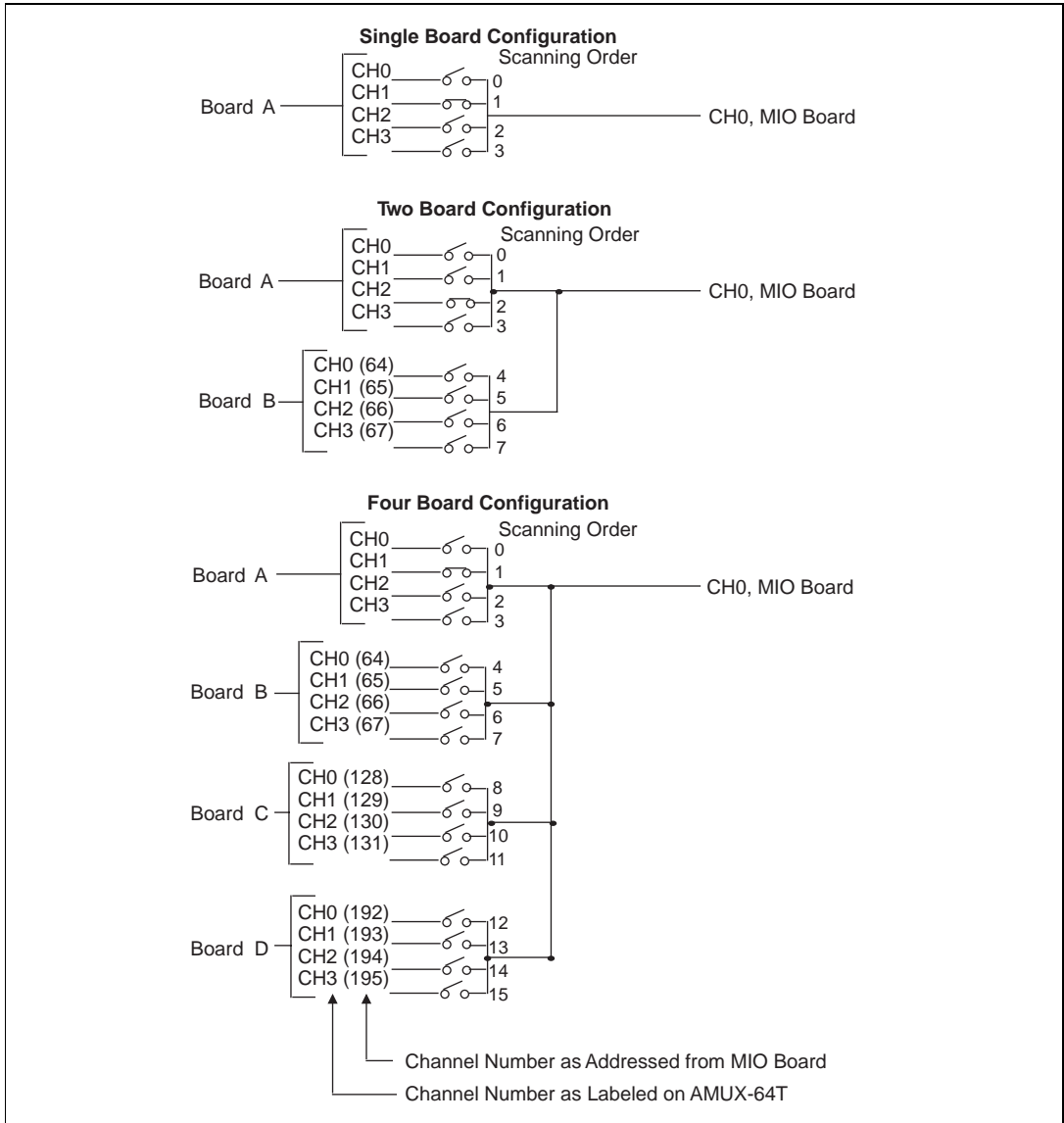

Figure 5-5. Scanning Order for Different AMUX-64T Board Configurations

Scanning Order

The order in which channels are scanned depends on the contents of the mux-gain memory. The mux-gain memory on the MIO board can be loaded with a sequence to scan the MIO onboard channels in any order. Figure 5-5 shows the scanning order on the AMUX-64T. Table 5-3 shows the order in which the AMUX-64T channels are scanned for every MIO board input channel for different AMUX-64T configurations. Observe that channels 0 through 15 of the MIO board are used for a single-ended input configuration, but only channels 0 through 7 are used for a differential input configuration.

Table 5-3. AMUX-64T Scanning Order for Each MIO Board Input Channel

MIO Board	AMUX-64T Channels						
	One Board	Two Boards		Four Boards			
	Board A	Board A	Board B	Board A	Board B	Board C	Board D
0	0–3	0–3	64–67	0–3	64–67	128–131	192–195
1	4–7	4–7	68–71	4–7	68–71	132–135	196–199
2	8–11	8–11	72–75	8–11	72–75	136–139	200–203
3	12–15	12–15	76–79	12–15	76–79	140–143	204–207
4	16–19	16–19	80–83	16–19	80–83	144–147	208–211
5	20–23	20–23	84–87	20–23	84–87	148–151	212–215
6	24–27	24–27	88–91	24–27	88–91	152–155	216–219
7	28–31	28–31	92–95	28–31	92–95	156–159	220–223
8	32–35	32–35	96–99	32–35	96–99	160–163	224–227
9	36–39	36–39	100–103	36–39	100–103	164–167	228–231
10	40–43	40–43	104–107	40–43	104–107	168–171	232–235
11	44–47	44–47	108–111	44–47	108–111	172–175	236–239
12	48–51	48–51	112–115	48–51	112–115	176–179	240–243
13	52–55	52–55	116–119	52–55	116–119	180–183	244–247
14	56–59	56–59	120–123	56–59	120–123	184–187	248–251
15	60–63	60–63	124–127	60–63	124–127	188–191	252–255

For example, if one AMUX-64T board is used, channels 0 through 3 on the AMUX-64T are automatically scanned whenever channel 0 on the MIO board is selected in the scan sequence. If two AMUX-64T boards are used, channels 0 through 3 (board A) and channels 64 through 67 (board B) are automatically scanned. If four AMUX-64T boards are used, channels 0 through 3 (board A), channels 64 through 67 (board B), channels 128 through 131 (board C), and channels 192 through 195 (board D) are automatically scanned.

If the MIO board is programmed with a sequential channel scan sequence (0 through 7 or 0 through 15), the AMUX-64T channels are scanned from top to bottom in the order given in Table 5-3.

If only one AMUX-64T board is used, the channels are scanned in the order 0 through 63 for single-ended configuration. The scanning order becomes complex only when more than one AMUX-64T board is used.

During interval scanning, the number of channels scanned during an interval is four times the channel scan sequence for one AMUX-64T board, eight times for two AMUX-64T boards, and sixteen times for four AMUX-64T boards.

Programming Channel Scanning with the AMUX-64T

To program the MIO board to conduct a scanning operation with the AMUX-64T, the following steps must be added to the instructions for programming multiple A/D conversions with channel scanning given in Chapter 4 of the user manual that came with your MIO board. These steps can be added any time before initiating the A/D conversions.

Initialize the AMUX-64T Scanning Counter

The DOUTEN0 bit in the MIO board Command Register 2 (this bit has different names depending on your MIO board) must be set in order to load the AMUX-64T scanning counter.

To initialize the AMUX-64T scanning counter, use the following programming sequence:

1. Write 0 to digital I/O port A.
2. Write to the External Strobe Register to load 0 into the AMUX-64T scanning counter.

Configure Counter 1 to Control the MIO Board Scanning Clock

Counter 1 on the MIO board is used to divide the onboard scanning clock controlling the scanning counter so that the onboard multiplexers switch at a slower rate than the AMUX-64T multiplexers. To program counter 1, use the following programming sequence. All operations are 16-bit write operations. All values given are hexadecimal.

- Write FF01 to the Am9513 Command Register to select the Counter 1 Mode Register.
- Write 0325 (hex) to the Am9513 Data Register to store the Counter 1 mode value.
- Write FF09 to the Am9513 Command Register to select the Counter 1 Load Register.
- Write the divide-down value to the Am9513 Data Register to load counter 4. The divide-down values are as follows:
 - One AMUX-64T board: 4 (hex)
 - Two AMUX-64T boards: 8 (hex)
 - Four AMUX-64T boards: 10 (hex)
- Write FF41 to the Am9513 Command Register to load counter 1.
- Write FFF1 to the Am9513 Command Register to step counter 1.
- Write FF21 to the Am9513 Command Register to arm counter 1.

After you apply this programming sequence, counter 1 is configured to divide-down SCANCLK during A/D conversions.

Set the SCANDIV Bit in MIO Command Register 1

To enable SCANCLK division, set the SCANDIV bit in Command Register 1.

After this programming sequence, the analog inputs on the AMUX-64T are automatically scanned during MIO-scanned A/D conversion operations.

Specifications

This appendix lists the specifications of the AMUX-64T. These specifications are typical at 25 °C unless otherwise noted.

Analog Input

Input Characteristics

Number of channels

Single board	64 single-ended or 32 differential
Two boards	128 single-ended or 64 differential
Four boards connected	256 single-ended or 128 differential

Input signal ranges

Differential analog	± 10 V, ± 5 V, 0 to 10 V (selectable on MIO board)
---------------------------	---

Max working voltage

(signal + common mode)	Each input should remain within ± 12 V of ground
------------------------------	---

Active overvoltage protection

(CH0–CH63)	± 35 V powered on ± 20 V powered off
------------------	---

On resistance	1 k Ω
---------------------	--------------

AMUX-64T Settling Times to 12-Bit Precision

Settling time to ± 0.5 LSB, 12-bit precision in μs

One AMUX-64T Board						
Gain	AT-MIO-16E-2		AT-MIO-16E-10		NB-MIO-16	
	$\pm\text{FS}$	0 to $+\text{FS}$	$\pm\text{FS}$	0 to $+\text{FS}$	$\pm\text{FS}$	0 to $+\text{FS}$
.5	5	3	9	8	—	—
1	5	3	9	8	14	12
2	5	3	9	8	—	—
5	5	3	9	8	—	—
10	6	4	9	8	20	15
20	6	5	10	9	—	—
50	7	6	11	10	—	—
100	9	8	12	11	20	20
500	—	—	—	—	50	50

Two AMUX-64T Boards						
Gain	AT-MIO-16E-2		AT-MIO-16E-10		NB-MIO-16	
	$\pm\text{FS}$	0 to $+\text{FS}$	$\pm\text{FS}$	0 to $+\text{FS}$	$\pm\text{FS}$	0 to $+\text{FS}$
.5	6	5	10	8	—	—
1	6	5	10	8	25	12
2	6	5	10	8	—	—
5	7	6	10	9	—	—
10	7	6	11	9	35	15
20	7	7	11	10	—	—
50	8	7	13	12	—	—
100	11	10	15	14	60	30
500	—	—	—	—	70	60

Four AMUX-64T Boards						
Gain	AT-MIO-16E-2		AT-MIO-16E-10		NB-MIO-16	
	±FS	0 to +FS	±FS	0 to +FS	±FS	0 to +FS
.5	8	8	13	12	—	—
1	8	8	13	12	25	12
2	9	8	13	12	—	—
5	9	9	13	12	—	—
10	9	9	13	12	50	30
20	11	10	14	13	—	—
50	11	11	15	14	—	—
100	14	13	17	16	70	50
500	—	—	—	—	110	100

Cold-Junction Sensor

Jumper selectable on differential channel 0

Output 10 mV/°C

Accuracy ±1.0 °C from 0 to 110 °C

Power Requirement

From computer through MIO board or external power

+5 VDC (±5%)..... 150 mA typ

Physical

Dimensions..... 12.75 by 3.80 in
(32.43 by 9.65 cm)

I/O connector..... Two 50-pin male ribbon-cable connectors, one 68-pin male shielded or ribbon-cable connector 78-screw terminals

Environment

Operating temperature0° to 70 °C

Storage temperature-55° to 150 °C

Relative humidity5% to 90% noncondensing

Customer Communication

For your convenience, this appendix contains forms to help you gather the information necessary to help us solve your technical problems and a form you can use to comment on the product documentation. When you contact us, we need the information on the Technical Support Form and the configuration form, if your manual contains one, about your system configuration to answer your questions as quickly as possible.

National Instruments has technical assistance through electronic, fax, and telephone systems to quickly provide the information you need. Our electronic services include a bulletin board service, an FTP site, a fax-on-demand system, and e-mail support. If you have a hardware or software problem, first try the electronic support systems. If the information available on these systems does not answer your questions, we offer fax and telephone support through our technical support centers, which are staffed by applications engineers.

Electronic Services

Bulletin Board Support

National Instruments has BBS and FTP sites dedicated for 24-hour support with a collection of files and documents to answer most common customer questions. From these sites, you can also download the latest instrument drivers, updates, and example programs. For recorded instructions on how to use the bulletin board and FTP services and for BBS automated information, call 512 795 6990. You can access these services at:

United States: 512 794 5422

Up to 14,400 baud, 8 data bits, 1 stop bit, no parity

United Kingdom: 01635 551422

Up to 9,600 baud, 8 data bits, 1 stop bit, no parity

France: 01 48 65 15 59

Up to 9,600 baud, 8 data bits, 1 stop bit, no parity

FTP Support

To access our FTP site, log on to our Internet host, `ftp.natinst.com`, as anonymous and use your Internet address, such as `joesmith@anywhere.com`, as your password. The support files and documents are located in the `/support` directories.

Fax-on-Demand Support

Fax-on-Demand is a 24-hour information retrieval system containing a library of documents on a wide range of technical information. You can access Fax-on-Demand from a touch-tone telephone at 512 418 1111.

E-Mail Support (Currently USA Only)

You can submit technical support questions to the applications engineering team through e-mail at the Internet address listed below. Remember to include your name, address, and phone number so we can contact you with solutions and suggestions.

support@natinst.com

Telephone and Fax Support

National Instruments has branch offices all over the world. Use the list below to find the technical support number for your country. If there is no National Instruments office in your country, contact the source from which you purchased your software to obtain support.

Country	Telephone	Fax
Australia	03 9879 5166	03 9879 6277
Austria	0662 45 79 90 0	0662 45 79 90 19
Belgium	02 757 00 20	02 757 03 11
Brazil	011 288 3336	011 288 8528
Canada (Ontario)	905 785 0085	905 785 0086
Canada (Québec)	514 694 8521	514 694 4399
Denmark	45 76 26 00	45 76 26 02
Finland	09 725 725 11	09 725 725 55
France	01 48 14 24 24	01 48 14 24 14
Germany	089 741 31 30	089 714 60 35
Hong Kong	2645 3186	2686 8505
Israel	03 6120092	03 6120095
Italy	02 413091	02 41309215
Japan	03 5472 2970	03 5472 2977
Korea	02 596 7456	02 596 7455
Mexico	5 520 2635	5 520 3282
Netherlands	0348 433466	0348 430673
Norway	32 84 84 00	32 84 86 00
Singapore	2265886	2265887
Spain	91 640 0085	91 640 0533
Sweden	08 730 49 70	08 730 43 70
Switzerland	056 200 51 51	056 200 51 55
Taiwan	02 377 1200	02 737 4644
United Kingdom	01635 523545	01635 523154
United States	512 795 8248	512 794 5678

Technical Support Form

Photocopy this form and update it each time you make changes to your software or hardware, and use the completed copy of this form as a reference for your current configuration. Completing this form accurately before contacting National Instruments for technical support helps our applications engineers answer your questions more efficiently.

If you are using any National Instruments hardware or software products related to this problem, include the configuration forms from their user manuals. Include additional pages if necessary.

Name _____

Company _____

Address _____

Fax (____) _____ Phone (____) _____

Computer brand _____ Model _____ Processor _____

Operating system (include version number) _____

Clock speed _____ MHz RAM _____ MB Display adapter _____

Mouse ____ yes ____ no Other adapters installed _____

Hard disk capacity _____ MB Brand _____

Instruments used _____

National Instruments hardware product model _____ Revision _____

Configuration _____

National Instruments software product _____ Version _____

Configuration _____

The problem is: _____

List any error messages: _____

The following steps reproduce the problem: _____

AMUX-64T Hardware and Software Configuration Form

Record the settings and revisions of your hardware and software on the line to the right of each item. Complete a new copy of this form each time you revise your software or hardware configuration, and use this form as a reference for your current configuration. Completing this form accurately before contacting National Instruments for technical support helps our applications engineers answer your questions more efficiently.

National Instruments Products

Hardware revision _____

Serial number _____

Temperature sensor selection (temperature or CH0 and CH32) _____

Power supply selection (internal or external) _____

Programming choice _____

National Instruments software _____

Other boards in system _____

NI-DAQ version _____

Other Products

Computer make and model _____

Microprocessor _____

Clock frequency or speed _____

Type of video board installed _____

Operating system version _____

Operating system mode _____

Programming language _____

Programming language version _____

Other boards in system _____

Documentation Comment Form

National Instruments encourages you to comment on the documentation supplied with our products. This information helps us provide quality products to meet your needs.

Title: *AMUX-64T User Manual*

Edition Date: January 1999

Part Number: 320253C-01

Please comment on the completeness, clarity, and organization of the manual.

If you find errors in the manual, please record the page numbers and describe the errors.

Thank you for your help.

Name _____

Title _____

Company _____

Address _____

E-Mail Address _____

Phone (____) _____ Fax (____) _____

Mail to: Technical Publications
National Instruments Corporation
6504 Bridge Point Parkway
Austin, Texas 78730-5039

Fax to: Technical Publications
National Instruments Corporation
512 794 5678

Glossary

Prefix	Meanings	Value
p-	pico	10^{-12}
n-	nano-	10^{-9}
μ -	micro-	10^{-6}
m-	milli-	10^{-3}
k-	kilo-	10^3
M-	mega-	10^6

Numbers/Symbols

°	degrees
>	greater than
≥	greater than or equal to
<	less than
-	negative of, or minus
Ω	ohms
%	percent
±	plus or minus
+	positive of, or plus
+5 V	+5 Volts signal

A

A	amperes
ACH <0..7>	Analog Channel 0 through 7 signals
ACK*	Acknowledge Input signal
A/D	analog-to-digital

ADC	analog-to-digital converter
AGND	Analog Ground signal
AISENSE/AIGND	Analog Input Sense/Analog Input Ground signal
ANSI	American National Standards Institute
AWG	American Wire Gauge

C

C	Celsius
CLKB1, CLKB2	Counter B1, B2 Clock signals
cm	centimeters
CMOS	complementary metallic oxide semiconductor
CNTINT	Counter Interrupt signal

D

D/A	digital-to-analog
D*/A	Data/Address signal
DAC	digital-to-analog converter
DAC OUTPUT UPDATE	DAC output update signal
DACWRT	DAC Write signal
DAC0OUT, DAC1OUT	Digital-to-Analog Converter 0, 1 Output signals
DAQ	data acquisition
DAQD*/A	Data Acquisition Board Data/Address Line signal
DATA	Data Lines at the Specified Port signal
dB	decibels
DC	direct current
DGND	Digital Ground signal
DIFF	differential

DIN	Deutsche Industrie Norme
DIP	dual-inline package
DMA	direct memory access
E	
EEPROM	electrically erased programmable read-only memory
EPP	Enhanced Parallel Port
EXTCONV*	External Convert signal
EXTTRIG	External Trigger signal
EXTUPDATE*	External Update signal
F	
ft	feet
G	
GATB <0..2>	Counter B0, B1, B2 Gate signals
H	
hex	hexadecimal
I	
IBF	Input Buffer Full signal
in.	inches
INTR	Interrupt Request signal
I/O	input/output
L	
LED	light-emitting diode
LSB	least significant bit

M

m	meters
max	maximum
MB	megabytes of memory
min	minutes
MIO	multifunction I/O
MSB	most significant bit

N

NRSE	nonreferenced single-ended
------	----------------------------

O

OBF*	Output Buffer Full signal
OUTB0, OUTB1	Counter B0, B1 Output signals

P

PA, PB, PC <0..7>	Port A, B, or C 0 through 7 signals
POSTTRIG	Posttrigger mode
PRETRIG	Pretrigger mode

R

RC	resistance-capacitance
RD*	Read signal
R _{EXT}	external resistance
RSE	referenced single-ended
RTSI	Real-Time System Integration

S

s	seconds
SCXI	Signal Conditioning eXtensions for Instrumentation (bus)
SDK	Software Developer's Kit
SERCLK	Serial Clock signal
SERDATIN	Serial Data In signal
SERDATOUT	Serial Data Out signal
SLOT0SEL*	Slot 0 Select signal
SPICLK	Serial Peripheral Interface Clock signal
SS*	Slot-select signal
STB	Strobe Input signal

T

TTL	transistor-transistor logic
typ	typical

U

UP/BP*	Unipolar/bipolar bit
--------	----------------------

V

V	volts
$V_{\pm in}$	positive/negative input voltage
V_{cm}	common-mode noise
V_{diff}	differential input voltage
VDC	volts direct current
V_{EXT}	external voltage
VI	virtual instrument
V_m	measured voltage

Glossary

V_{rms} volts, root-mean-square

V_s signal source

W

W watts

WRT* Write signal

Index

A

- accuracy of thermocouple measurement, 3-13
- addressing AMUX-64T analog input channels
 - A/D conversions on single analog input channel, 5-3 to 5-6
 - channel address mapping (figure), 5-6
 - channel selection (table), 5-4
 - multiple AMUX-64T board addressing (table), 5-5
 - scanning counter control bits (figure), 5-3
- AMUX-64T
 - block diagram, 4-2
 - damaged equipment (warning), 3-1
 - features, 1-1
 - optional equipment, 1-7
 - overview, 1-1
 - parts locator diagram (figure), 2-2
 - requirements for getting started, 1-2
 - software programming choices, 1-2 to 1-6
 - LabVIEW and LabWindows application software, 1-3
 - NI-DAQ driver software, 1-3 to 1-5
 - register-level programming, 1-6
 - unpacking, 1-2
- analog input, 4-1 to 4-4
 - A/D conversions on single channel, 5-3 to 5-6
 - component positions in each channel (table), 4-2 to 4-4
 - input characteristics specifications, A-1
 - onboard equivalent circuit (figure), 4-2
- attenuators (voltage dividers), building, 4-12 to 4-14
 - attenuators for use with differential inputs (figure), 4-13
 - input voltage greater than 42 V (warning), 4-12

automatic channel scanning. *See* channel scanning.

B

- block diagram of AMUX-64T (figure), 5-2
- board configuration. *See* configuration.
- bulletin board support, B-1

C

- cables. *See also* shield selection.
 - optional equipment, 1-7
- CH0–CH63 screw terminals, never connecting signals to (caution), 3-1
- channel scanning
 - automatic, 5-7 to 5-9
 - scanning order for different configurations (figure), 5-9
 - two-level multiplexer arrangement (figure), 5-7
 - programming, 5-11 to 5-12
 - configuring Counter 1 to control MIO board scanning clock, 5-12
 - initializing AMUX-64T scanning counter, 5-11
 - setting SCANDIV bit in MIO Command Register 1, 5-12
 - scanning counter control bits (figure), 5-3
 - scanning order
 - description, 5-10 to 5-11
 - MIO board input channels (table), 5-10
- channels
 - A/D conversions on single analog input channel, 5-3 to 5-6
 - channel address mapping (figure), 5-6
 - channel selection (table), 5-4

- multiple AMUX-64T board
 - addressing (table), 5-5
 - scanning counter control bits (figure), 5-3
- addressing analog input channels, 5-3 to 5-6
- component positions in each channel (table), 4-2 to 4-4
- configuring input mode, 4-5
- cold-junction compensation, 3-5
- cold-junction sensor specifications, A-3
- configuration, 2-1 to 2-10
 - channel configurations, 4-5
 - four-board configuration
 - instructions, 2-9
 - switch settings (table), 2-10
 - jumpers and switches on AMUX-64T, 2-1
 - multiple board configuration
 - channel ranges for multiple boards (table), 2-8
 - daisy-chaining multiple boards (figure), 2-8
 - jumper settings (table), 2-7
 - parts locator diagram (figure), 2-2
 - power supply selection
 - MIO board power budget (table), 2-5
 - supplementary information, 2-4 to 2-5
 - switch settings (table), 2-3
 - shield selection
 - jumper settings (table), 2-4
 - supplementary information, 2-6
 - single board configuration
 - factory settings, 2-9
 - jumper settings (table), 2-7
 - temperature sensor selection
 - jumper settings (table), 2-3
 - supplementary information, 2-5 to 2-6

- two-board configuration
 - instructions, 2-9
 - switch settings (table), 2-9
- customer communication, *xii*, B-1 to B-2

D

- differential inputs
 - ground-referenced signal sources, 4-7
 - nonreferenced or floating signal sources, 4-5 to 4-6
 - signal connections, 3-5
- differential measurement of thermocouples
 - example, 3-9 to 11
 - procedure, 3-9
- documentation
 - conventions used in manual, *x*
 - National Instruments documentation, *xi*
 - organization of manual, *ix-x*
 - related documentation, *xi*

E

- electronic support services, B-1 to B-2
- e-mail support, B-2
- environment specifications, A-4
- equipment, optional, 1-7
- errors in thermocouple measurement, sources of, 3-12

F

- fax and telephone support numbers, B-2
- Fax-on-Demand support, B-2
- filters. *See* highpass filters; lowpass filters.
- floating signal sources, 4-5 to 4-6
 - bias return resistor for DC-coupled floating source (figure), 4-6
 - differential inputs, 4-5 to 4-6
 - single-ended inputs, 4-6
- FTP support, B-1

G

gain and input ranges for thermocouples,
selecting, 3-5 to 3-6

ground-referenced signal sources
differential inputs, 4-7
single-ended inputs, 4-7

H

highpass filters
building, 4-10 to 4-12
highpass filter on differential channel 1
(figure), 4-12
normalized frequency response
(figure), 4-10

I

input modes, configuring, 4-5

installation
cable positioning (figure), 2-11
instructions, 2-10
power-on sequence, 2-11
unpacking the AMUX-64T, 1-2

I/O connector (J1, J2, and J42), 3-1 to 3-4
AMUX-64T signal routing (figure), 3-4
pin mapping for J1, J2, and J42 (table),
3-2 to 3-3

J

jumpers and switches. *See* configuration.

L

LabVIEW and LabWindows application
software, 1-3

linearizing thermocouple data, 3-6 to 3-9

lowpass filters
building, 4-8 to 4-9

lowpass filter on differential channel 1
(figure), 4-9
normalized frequency response (figure),
4-8 to 4-9

M

manual. *See* documentation.

MIO board power budget (table), 2-5

multiple-board configuration. *See*
configuration.

N

National Institute of Standards and
Technology (NIST) polynomial coefficients
for thermocouples (table), 3-8

NI-DAQ driver software, 1-3 to 1-5

nonreferenced or floating signal sources,
4-5 to 4-6
bias return resistor for DC-coupled
floating source (figure), 4-6
differential inputs, 4-5 to 4-6
single-ended inputs, 4-6

O

onboard temperature sensor. *See* temperature
sensor selection.

operation of AMUX-64T. *See* theory of
operation.

optional equipment, 1-7

P

parts locator diagram (figure), 2-2

physical specifications, A-3

pin mapping. *See* I/O connector (J1, J2, and
J42).

polynomial coefficients for thermocouples
(table), 3-8

power requirement specifications, A-3

- power supply selection
 - MIO board power budget (table), 2-5
 - supplementary information, 2-4 to 2-5
 - switch settings (table), 2-3
- power-on sequence, 2-11
- programming channel scanning, 5-11 to 5-12
 - configuring Counter 1 to control MIO board scanning clock, 5-12
 - initializing AMUX-64T scanning counter, 5-11
 - setting SCANDIV bit in MIO Command Register 1, 5-12

R

- register-level programming, 1-6
- requirements for getting started, 1-2
- resistance-capacitance (RC) filters. *See* highpass filters; lowpass filters.

S

- scanning. *See* channel scanning.
- screw terminals CH0–CH63, never connecting signals to (caution), 3-1
- Seebeck coefficient, 3-6
- settling times to 12-bit precision, A-2 to A-3
 - four AMUX-64T boards (table), A-3
 - single AMUX-64T board (table), A-2
 - two AMUX-64T boards (table), A-2
- shield selection
 - jumper settings (table), 2-4
 - supplementary information, 2-6
- signal conditioning, 4-1 to 4-14
 - analog input, 4-1 to 4-4
 - component positions in each channel (table), 4-2 to 4-4
 - onboard equivalent circuit (figure), 4-2
 - application notes, 4-4 to 4-14

- building attenuators (voltage dividers), 4-12 to 4-14
 - attenuators for use with differential inputs (figure), 4-13
 - input voltage greater than 42 V (warning), 4-12
- building highpass filters, 4-10 to 4-12
 - highpass filter on differential channel 1 (figure), 4-12
 - normalized frequency response (figure), 4-10
- building lowpass filters, 4-8 to 4-9
 - lowpass filter on differential channel 1 (figure), 4-9
 - normalized frequency response (figure), 4-8 to 4-9
- channel configurations, 4-5
- connecting ground-referenced signal sources, 4-7
 - differential inputs, 4-7
 - single-ended inputs, 4-7
- connecting nonreferenced or floating signal sources, 4-5 to 4-6
 - differential inputs, 4-5 to 4-6
 - single-ended inputs, 4-6
- soldering and desoldering on AMUX-64T board, 4-4
- signal connections, 3-1 to 3-14
 - cautions and warnings, 3-1
 - differential connections, 3-5
 - exceeding maximum input ratings (warning), 3-1
 - I/O connector, 3-1 to 3-4
 - AMUX-64T signal routing (figure), 3-4
 - pin mapping for J1, J2, and J42 (table), 3-2 to 3-3
 - other connection considerations, 3-14
 - thermocouple measurements using AMUX-64T, 3-5 to 3-13
 - differential measurements, 3-9

- examples (differential or single-ended), 3-9 to 3-11
- linearizing the data, 3-6 to 3-9
- NIST polynomial coefficients for thermocouples (table), 3-8
- selecting gain and input ranges, 3-5 to 3-6
- single-ended measurement, 3-11
- sources of error, 3-12 to 3-13
- thermocouple measurement accuracies, 3-13
- thermocouple output extremes (table), 3-6
- using more than one AMUX-64T, 3-12
- single-board configuration. *See* configuration.
- single-ended inputs
 - ground-referenced signal sources, 4-7
 - nonreferenced or floating signal sources, 4-6
- single-ended thermocouple measurement
 - example, 3-9 to 3-11
 - procedure, 3-11
- software programming choices
 - LabVIEW and LabWindows application software, 1-3
 - NI-DAQ driver software, 1-3 to 1-5
 - register-level programming, 1-6
- soldering and desoldering on AMUX-64T board, 4-4
- specifications
 - AMUX-64T settling times to 12-bit precision, A-2 to A-3
 - analog input, A-1
 - cold-junction sensor, A-3
 - environment, A-4
 - physical, A-3
 - power requirement, A-3
- switch settings. *See* configuration.

T

- technical support, B-1 to B-2
- telephone and fax support numbers, B-2
- temperature sensor selection
 - jumper settings (table), 2-3
 - supplementary information, 2-5 to 2-6
- theory of operation, 5-1 to 5-11
 - A/D conversions on single analog input channel, 5-3 to 5-6
 - channel address mapping (figure), 5-6
 - channel selection (table), 5-4
 - multiple AMUX-64T board addressing (table), 5-5
 - scanning counter control bits (figure), 5-3
 - addressing analog input channels, 5-3 to 5-6
 - automatic channel scanning, 5-7 to 5-9
 - scanning order for different configurations (figure), 5-9
 - two-level multiplexer arrangement (figure), 5-7
 - block diagram of AMUX-64T (figure), 5-2
 - functional overview, 5-1 to 5-3
 - scanning order, 5-10 to 5-11
- thermocouple measurements using AMUX-64T, 3-5 to 3-13
 - differential measurements, 3-9
 - examples (differential or single-ended), 3-9 to 3-11
 - linearizing the data, 3-6 to 3-9
 - NIST polynomial coefficients for thermocouples (table), 3-8
 - selecting gain and input ranges, 3-5 to 3-6
 - single-ended measurement, 3-11
 - sources of error, 3-12 to 3-13
 - thermocouple measurement accuracies, 3-13

thermocouple output extremes (table), 3-6
using more than one AMUX-64T, 3-12

U

unpacking the AMUX-64T, 1-2

V

voltage dividers. *See* attenuators (voltage dividers), building.