

NOTE TO USERS

Retrofitting Your PXI Module

Using an EMI Gasket to Reduce High-Frequency Emissions

このドキュメントには、日本語ページも含まれています。

If the PXI module to the left of your PXI module does not have an EMI gasket, you may encounter the effects of increased high-frequency emissions. To reduce these emissions, you should install the EMI gasket provided with your module.

This document describes the procedure for adding an EMI gasket to your PXI module. Refer to Figure 1 as you install the gasket.

To install the EMI gasket, complete the following steps:

1. Power down the PXI chassis.
2. Remove your PXI module from the PXI chassis.
3. Remove the adhesive backing from the EMI gasket.
4. Apply the gasket, positioning the long, straight edge toward the back of the module, as shown in Figure 1. The gasket *must* be flush with the side of the module.
5. Reinstall your PXI module in the chassis. Refer to your module documentation for installation instructions.

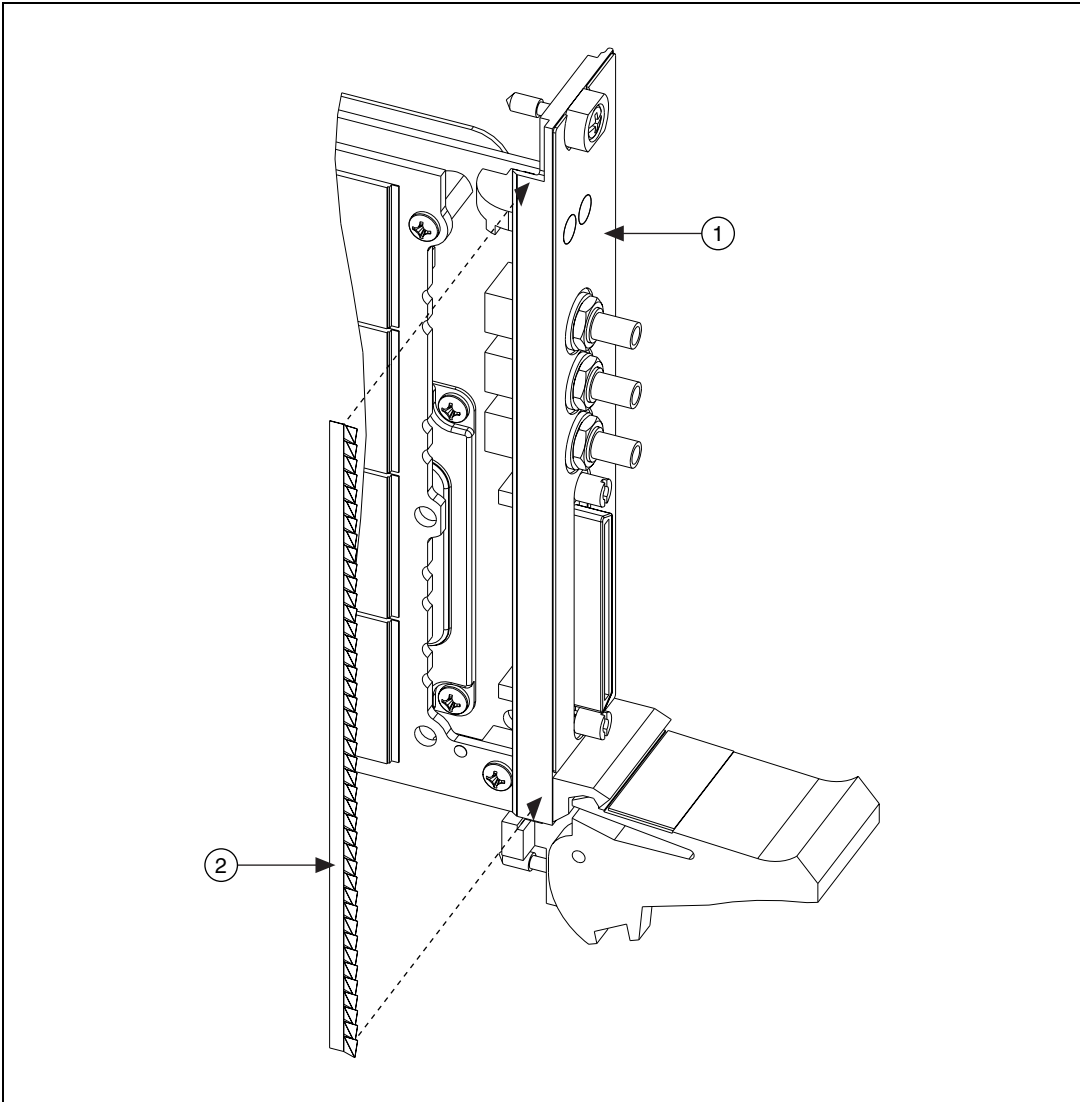

1 PXI Module

2 EMI Gasket

Figure 1. Gasket Placement on a PXI Module

National Instruments, NI, ni.com, and LabVIEW are trademarks of National Instruments Corporation. Refer to the *Terms of Use* section on ni.com/legal for more information about National Instruments trademarks. Other product and company names mentioned herein are trademarks or trade names of their respective companies. For patents covering National Instruments products, refer to the appropriate location: **Help»Patents** in your software, the `patents.txt` file on your media, or ni.com/patents.