

Fieldpoint™ Operating Instructions

FP-DO-410 and cFP-DO-410

Eight-Channel, 5–30 V Protected Digital Output Module

These operating instructions describe how to install and use the National Instruments FP-DO-410 and cFP-DO-410 digital output modules (referred to inclusively as the [c]FP-DO-410). For information about configuring and accessing the [c]FP-DO-410 over a network, refer to the user manual for the FieldPoint network module you are using.

Features

The [c]FP-DO-410 is a FieldPoint digital output module with the following features:

- Eight digital output channels
- Sourcing outputs that supply up to 1 A per channel
- Compatible with voltages from 5 to 30 VDC
- On/Off LED indicators
- Short-circuit protection with LED indicators
- 250 V_{rms} CAT II continuous channel-to-ground isolation, verified by 2,300 V_{rms}, 5 s dielectric withstand test
- Hot swappable
- –40 to 70 °C operation

Installing the FP-DO-410

The FP-DO-410 mounts on a FieldPoint terminal base (FP-TB-*x*), which provides operating power to the module. Installing the FP-DO-410 onto a powered terminal base does not disrupt the operation of the FieldPoint bank.

To install the FP-DO-410, refer to Figure 1 and complete the following steps:

1. Slide the terminal base key to either position X, used for any module, or position 4, used for the FP-DO-410 module.
2. Align the FP-DO-410 alignment slots with the guide rails on the terminal base.
3. Press firmly to seat the FP-DO-410 on the terminal base. When the module is firmly seated, the terminal base latch locks it into place.

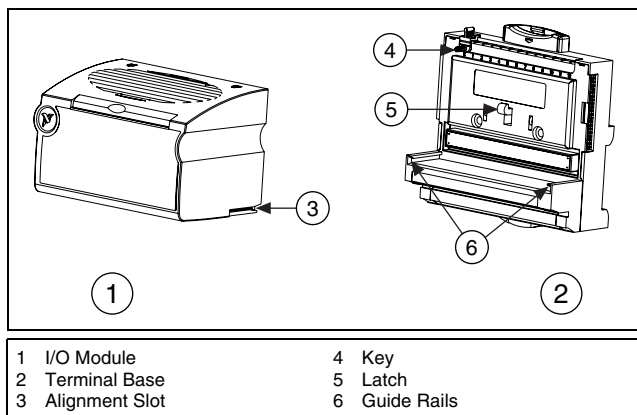

Figure 1. Installing the FP-DO-410

Installing the cFP-DO-410

The cFP-DO-410 mounts on a Compact FieldPoint backplane (cFP-BP-*x*), which provides operating power to the module. Installing the cFP-DO-410 onto a powered backplane does not disrupt the operation of the FieldPoint bank.

To install the cFP-DO-410, refer to Figure 2 and complete the following steps:

1. Align the captive screws on the cFP-DO-410 with the holes on the backplane. The alignment keys on the cFP-DO-410 prevent backward insertion.
2. Press firmly to seat the cFP-DO-410 on the backplane.

- Using a number 2 Phillips screwdriver with a shank of at least 64 mm (2.5 in.) length, tighten the captive screws to 1.1 N · m (10 lb · in.) of torque. The nylon coating on the screws prevents them from loosening.

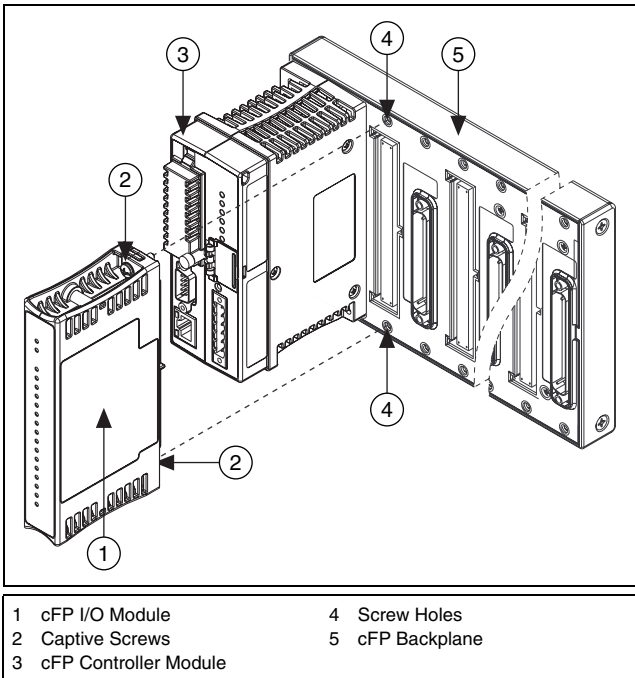

Figure 2. Installing the cFP-DO-410

Wiring the [c]FP-DO-410

The FP-TB-*x* terminal base has connections for each of the eight output channels and for an external power supply to power the output channels and field devices. The cFP-CB-1 connector block provides the same connections. Each channel has one output terminal (V_{OUT}), one supply terminal (V_{SUP}), and two common terminals (COM). All eight channels are referenced to the COM terminals. The V and V_{SUP} terminals are all internally connected, as are the C and COM terminals.

Use a 5–30 VDC external power supply for the output channels. The power supply must provide enough current to power all of the loads on the output channels, up to 1 A per channel.¹ Connect the external power supply to multiple V and V_{SUP} terminals and to multiple C and COM terminals as needed to ensure that the maximum current through any terminal is 2 A or less.

Install a 2 A maximum, fast-acting fuse between the external power supply and the V_{SUP} terminal on each channel. Install a 1 A maximum, fast-acting fuse suitable for the load at the V_{OUT} terminal. Figure 3 shows fuses where appropriate.

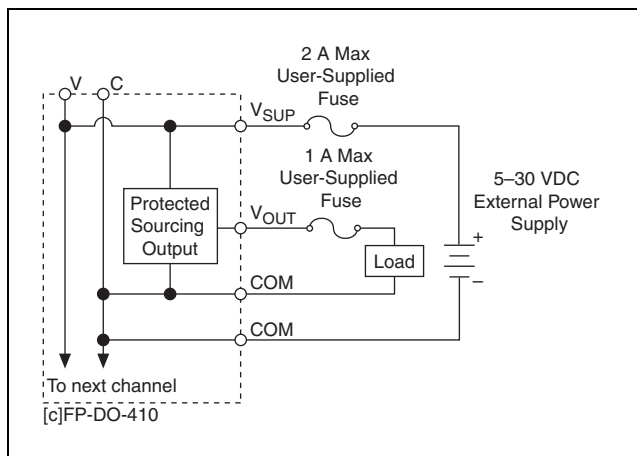

Figure 3. Recommended Field Connections

Table 1 lists the terminal assignments for the signals of each channel. Terminal assignments are also listed on the side panel of the cFP-DO-410 and under the slide-in card on the front of the FP-DO-410.

¹ The maximum output current is 0.5 A per channel for a cFP-DO-410 operating at 55–70 °C.

Table 1. Terminal Assignments

Channel	Terminal Numbers		
	V _{OUT} [*]	V _{SUP} [†]	COM
0	1	17	2, 18
1	3	19	4, 20
2	5	21	6, 22
3	7	23	8, 24
4	9	25	10, 26
5	11	27	12, 28
6	13	29	14, 30
7	15	31	16, 32

* Install a 1 A maximum, fast-acting fuse on each V_{OUT} terminal.
† Install a 2 A maximum, fast-acting fuse on each V and V_{SUP} terminal.

Digital Output Circuit

The [c]FP-DO-410 digital output channels are optically isolated from the rest of the FieldPoint bank. The channels are sourcing outputs with short-circuit protection circuitry. *Sourcing* current means that the output terminal provides a path to a voltage supply.

In the ON state, a transistor is turned on between the positive external supply voltage (V and V_{SUP}) and the output (V_{OUT}). In the OFF state, this transistor is turned off, allowing only a small leakage current to flow.

Ensure that the load on any channel does not draw more than 1 A, and the total current supplied by all channels at any one time is no more than 8 A.



Caution For a cFP-DO-410 operating in the 55–70 °C temperature range, the output current must not exceed 0.5 A on any channel.

In the ON state, the effective resistance between the output (V_{OUT}) and the supply voltage (V and V_{SUP}) is 0.3Ω . This resistance causes a voltage drop between the external supply voltage and the output voltage. Table 2 lists the actual output voltages based on the voltage provided by the external power supply.

Table 2. [c]FP-DO-410 Output Voltages for a 0.5 A Current Flow

V	V_{OUT}
5	4.85
10	9.85
12	11.85
24	23.85
30	29.85

If the external power supply you are using does not provide one of the voltages in Table 2, use the following equation to calculate the actual voltage output.

$$ActualOutput = V_{ext} - (I_{flow} \times 0.3 \Omega)$$

where $ActualOutput$ is the voltage sourced by V_{OUT}

V_{ext} is the voltage provided by the external power supply

I_{flow} is the current flow through the V_{OUT} terminal

Protection for Inductive Loads

When an inductive load, such as a motor or relay, is connected to an output, a large counter-electromotive force may occur at switching time because of the energy stored in the inductive load. This *flyback voltage* can damage the outputs and the power supply.

It is best to limit flyback voltages by installing a flyback diode across an inductive load. Typically you should mount the flyback diode within 18 in. of the load. Figure 4 shows one channel connected to an inductive load with a flyback diode.

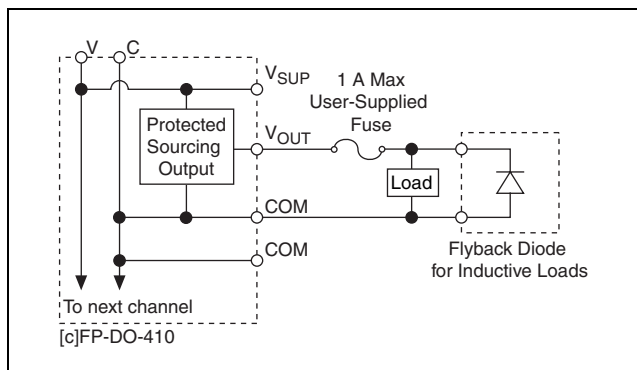

Figure 4. Inductive Load with Flyback Diode

The [c]FP-DO-410 contains flyback diodes to prevent excessively high voltage from damaging the module. Nevertheless, National Instruments recommends using an external protection circuit across any inductive load.

Short-Circuit Protection

If the protection circuitry detects a short-circuit condition on an output channel, it disables the output. If the protection circuitry disables an output that would otherwise be in the ON state, the status indicator for that channel is still lit, but the output transistor is turned off. Short-circuit protection is not a substitute for the 1 A fuse required on each channel.

Detecting a Short-Circuit Condition

When a channel is short-circuited, the red short-circuit LED for that channel lights and the module returns an error status message to the network module.

Resetting a Channel in a Short-Circuit Condition

To reset a channel in a short-circuit condition, determine the cause of the condition and disconnect the load from the channel. The channel resets automatically when the load is removed.

Alternatively, if completely removing the channel load is not convenient, reset the channel in any of the following ways:

- In FieldPoint software, write a 0 to the channel. The channel resets immediately.
- Disconnect the external power supply from the [c]FP-DO-410.
- Remove the [c]FP-DO-410 from the bank.
- Power off the network module connected to the [c]FP-DO-410.

Normal operation can resume after you correct the short-circuit condition.

Status Indicators

The [c]FP-DO-410 has two green status LEDs, **POWER** and **READY**. After you install the [c]FP-DO-410 onto a terminal base or backplane and apply power to the connected network module, the green **POWER** indicator lights and the [c]FP-DO-410 informs the network module of its presence. When the network module recognizes the [c]FP-DO-410, it sends initial configuration information to the [c]FP-DO-410. After the [c]FP-DO-410 receives this initial information, the green **READY** indicator lights and the module is in normal operating mode.

In addition to the green **POWER** and **READY** indicators, each channel has two status LEDs. The green LED lights when the channel is in the ON state. The red LED lights when the channel is short-circuited. For more information about short-circuit protection, refer to the [Short-Circuit Protection](#) section.

Upgrading the FieldPoint Firmware

You may need to upgrade the FieldPoint firmware when you add new I/O modules to the FieldPoint system. For information on determining which firmware you need and how to upgrade your firmware, go to ni.com/info and enter `fpmatrix`.

Isolation and Safety Guidelines



Caution Read the following information before attempting to connect the [c]FP-DO-410 to any circuits that may contain *hazardous voltages*.¹

This section describes the isolation of the [c]FP-DO-410 and its compliance with international safety standards. The field wiring connections are isolated from the backplane and the inter-module communication bus. The isolation barriers in the module provide 250 V_{rms} Measurement Category II continuous channel-to-backplane and channel-to-ground isolation, verified by a 2,300 V_{rms}, 5 s dielectric withstand test.² The [c]FP-DO-410 provides *double insulation* compliant with IEC 61010-1 for working voltages of 250 V_{rms}.³ Safety standards (such as those published by UL and IEC) require the use of double insulation between hazardous voltages and any human-accessible parts or circuits.

Never try to use any isolation product between human-accessible parts (such as DIN rails or monitoring stations) and circuits that can be at hazardous potentials under normal conditions, unless the product is specifically designed for such an application, as is the [c]FP-DO-410.

Even though the [c]FP-DO-410 is designed to handle applications with hazardous potentials, follow these guidelines to ensure a safe total system:

- There is no isolation between channels on the [c]FP-DO-410. If a hazardous voltage is present on any channel, all channels are considered hazardous. Make sure that all other devices and circuits connected to the module are properly insulated from human contact.
- Do *not* share the external supply voltages (the V and C terminals) with other devices, including other FieldPoint devices, unless those devices are isolated from human contact.

¹ A hazardous voltage is a voltage greater than 42.4 V_{peak} or 60 VDC. When a hazardous voltage is present on any channel, all of the channels must be considered to be carrying hazardous voltages. Ensure that all circuits connected to the module are inaccessible to human touch.

² Refer to the [Isolation Voltage](#) section for more information about isolation on the [c]FP-DO-410.

³ *Working voltage* is defined as the signal voltage plus the common-mode voltage. *Common-mode voltage* is the voltage of the module with respect to ground.

- For Compact FieldPoint, you *must* connect the protective earth (PE) ground terminal on the cFP-BP-*x* backplane to the system safety ground. The backplane PE ground terminal has the following symbol stamped beside it: . Connect the backplane PE ground terminal to the system safety ground using 14 AWG (1.6 mm) wire with a ring lug. Use the 5/16 in. panhead screw shipped with the backplane to secure the ring lug to the backplane PE ground terminal.
- As with any hazardous voltage wiring, make sure that all wiring and connections meet applicable electrical codes and commonsense practices. Mount terminal bases and backplanes in an area, position, or cabinet that prevents accidental or unauthorized access to wiring that carries hazardous voltages.
- Do *not* use the [c]FP-DO-410 as the only isolating barrier between human contact and working voltages higher than 250 V_{rms}.
- Operate the [c]FP-DO-410 only at or below Pollution Degree 2. Pollution Degree 2 means that only nonconductive pollution occurs in most cases. Occasionally, however, condensation causes temporary conductivity.
- Operate the [c]FP-DO-410 at or below Measurement Category II. Measurement Category II is for measurements performed on circuits directly connected to the low-voltage installation. This category refers to local-level distribution, such as that provided by a standard wall outlet.

Safety Guidelines for Hazardous Locations

The cFP-DO-410 is suitable for use in Class I, Division 2, Groups A, B, C, D, T4 hazardous locations; Class I, Zone 2, AEx nC IIC T4 and Ex nC IIC T4 hazardous locations; and nonhazardous locations only. Follow these guidelines if you are installing the cFP-DO-410 in a potentially explosive environment. Not following these guidelines may result in serious injury or death.



Caution Do *not* disconnect I/O-side wires or connectors unless power has been switched off or the area is known to be nonhazardous.



Caution Do *not* remove modules unless power has been switched off or the area is known to be nonhazardous.



Caution Substitution of components may impair suitability for Class I, Division 2.



Caution For Zone 2 applications, install the Compact FieldPoint system in an enclosure rated to at least IP 54 as defined by IEC 60529 and EN 60529.



Caution For Zone 2 applications, install a protection device across the external power supply and the COM terminal. The device must prevent the external power supply voltage from exceeding 42 V if there is a transient overvoltage condition.

Special Conditions for Hazardous Locations Use in Europe

This equipment has been evaluated as EEx nC IIC T4 equipment under DEMKO Certificate No. 03 ATEX 0251502X. Each module is marked Ex II 3G and is suitable for use in Zone 2 hazardous locations.

Specifications

The following specifications are typical for the -40 to 70 °C temperature range unless otherwise noted.

Output Characteristics

Number of channels	8
Output type	Sourcing
Voltage range	5–30 VDC
Output impedance	0.3 Ω (0.3 V drop at 1 A)
Maximum output current	
Per channel	1 A (0.5 A for cFP-DO-410 operating at 55–70 °C)
Maximum leakage current	
OFF state	50 μ A
Short-circuit condition.....	1 mA

Physical Characteristics

Indicators	Green POWER and READY indicators, eight green output state indicators, eight red overcurrent state indicators
------------------	---

Weight

FP-DO-410	140 g (4.9 oz)
cFP-DO-410	110 g (3.9 oz)

Power Requirements

Power from network module	450 mW; 620 mW if some or all channels are in short-circuit condition
---------------------------------	---

Isolation Voltage

Isolation voltage is verified by a dielectric withstand test.

Channel-to-ground isolation

Continuous	250 V _{rms} , Measurement Category II
Dielectric withstand.....	2,300 V _{rms} , 5 s max

Channel-to-channel isolation

None

Environmental

FieldPoint modules are intended for indoor use only. For outdoor use, they must be mounted inside a sealed enclosure.

Operating temperature

-40 to 70 °C

Storage temperature

-55 to 85 °C

Humidity

10 to 90% RH,
noncondensing

Maximum altitude.....

2,000 m

Pollution Degree

2

Shock and Vibration

These specifications apply only to the cFP-DO-410.

NI recommends Compact FieldPoint if your application is subject to shock and vibration.

Operating vibration, random

(IEC 60068-2-64).....

10-500 Hz, 5 g_{rms}

Operating vibration, sinusoidal

(IEC 60068-2-6).....

10-500 Hz, 5 g

Operating shock (IEC 60068-2-27).....	50 g, 3 ms half sine, 18 shocks at 6 orientations; 30 g, 11 ms half sine, 18 shocks at 6 orientations
--	--

Safety

This product is designed to meet the requirements of the following standards of safety for electrical equipment for measurement, control, and laboratory use:

- IEC 61010-1, EN-61010-1
- UL 61010-1, CSA 61010-1



Note For UL and other safety certifications, refer to the product label or visit ni.com/certification, search by model number or product line, and click the appropriate link in the Certification column.

Electromagnetic Compatibility

This product is designed to meet the requirements of the following standards of EMC for electrical equipment for measurement, control, and laboratory use:

- EN 61326 EMC requirements; Industrial Immunity
- EN 55011 Emissions; Group 1, Class A
- CE, C-Tick, ICES, and FCC Part 15 Emissions; Class A

CE Compliance

This product meets the essential requirements of applicable European Directives, as amended for CE marking, as follows:

- 73/23/EEC; Low-Voltage Directive (safety)
- 89/336/EEC; Electromagnetic Compatibility Directive (EMC)



Note Refer to the Declaration of Conformity (DoC) for this product for any additional regulatory compliance information. To obtain the DoC for this product, visit ni.com/certification, search by model number or product line, and click the appropriate link in the Certification column.

Waste Electrical and Electronic Equipment (WEEE)



EU Customers At the end of their life cycle, all products *must* be sent to a WEEE recycling center. For more information about WEEE recycling centers and National Instruments WEEE initiatives, visit ni.com/environment/weee.htm.

Mechanical Dimensions

Figure 5 shows the mechanical dimensions of the FP-DO-410 installed on a terminal base. If you are using the cFP-DO-410, refer to the Compact FieldPoint controller user manual for the dimensions and cabling clearance requirements of the Compact FieldPoint system.

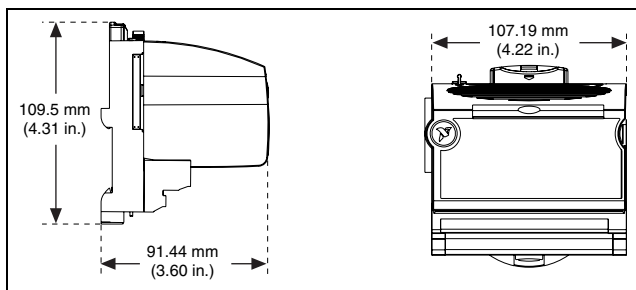

Figure 5. FP-DO-410 Mechanical Dimensions

Where to Go for Support

For more information about setting up the FieldPoint system, refer to these National Instruments documents:

- FieldPoint network module user manual
- Other FieldPoint I/O module operating instructions
- FieldPoint terminal base and connector block operating instructions

Go to ni.com/support for the most current manuals, examples, and troubleshooting information.

National Instruments corporate headquarters is located at 11500 North Mopac Expressway, Austin, Texas, 78759-3504. National Instruments also has offices located around the world to help address your support needs. For telephone support in the United States, create your service request at ni.com/support and follow the calling instructions or dial 512 795 8248. For telephone support outside the United States, contact your local branch office:

Australia 1800 300 800, Austria 43 0 662 45 79 90 0,
Belgium 32 0 2 757 00 20, Brazil 55 11 3262 3599,
Canada (Calgary) 403 274 9391, Canada (Ottawa) 613 233 5949,
Canada (Québec) 450 510 3055, Canada (Toronto) 905 785 0085,
Canada (Vancouver) 514 685 7530, China 86 21 6555 7838,
Czech Republic 420 224 235 774, Denmark 45 45 76 26 00,
Finland 385 0 9 725 725 11, France 33 0 1 48 14 24 24,
Germany 49 0 89 741 31 30, Greece 30 2 10 42 96 427,
India 91 80 41190000, Israel 972 0 3 6393737,
Italy 39 02 413091, Japan 81 3 5472 2970,
Korea 82 02 3451 3400, Malaysia 603 9131 0918,
Mexico 001 800 010 0793, Netherlands 31 0 348 433 466,
New Zealand 0800 553 322, Norway 47 0 66 90 76 60,
Poland 48 22 3390150, Portugal 351 210 311 210,
Russia 7 495 783 68 51, Singapore 65 6226 5886,
Slovenia 386 3 425 42 00, South Africa 27 0 11 805 8197,
Spain 34 91 640 0085, Sweden 46 0 8 587 895 00,
Switzerland 41 56 200 51 51, Taiwan 886 2 2528 7227,
Thailand 662 992 7519, United Kingdom 44 0 1635 523545

National Instruments, NI, ni.com, and LabVIEW are trademarks of National Instruments Corporation. Refer to the *Terms of Use* section on ni.com/legal for more information about National Instruments trademarks. Other product and company names mentioned herein are trademarks or trade names of their respective companies. For patents covering National Instruments products, refer to the appropriate location: **Help»Patents** in your software, the `patents.txt` file on your CD, or ni.com/patents.

© 2002–2006 National Instruments Corp. All rights reserved.