

FieldPoint Operating Instructions

FP-DO-403 and cFP-DO-403

16-Channel, 5 to 30 V Sinking Digital Output Module

These operating instructions describe how to install and use the National Instruments FP-DO-403 and cFP-DO-403 digital output modules, referred to inclusively as the [c]FP-DO-403. For information about configuring and accessing the [c]FP-DO-403 over a network, refer to the user manual for the FieldPoint network module you are using.

Features

The [c]FP-DO-403 is a FieldPoint digital output module with the following features:

- 16 sinking digital output channels
- Outputs sink 2 A per channel, 16 A² per module
- Compatible with voltages from 5 to 30 VDC
- 250 V_{rms} CAT II continuous channel-to-ground isolation, verified by 2,300 V_{rms}, 5 s dielectric withstand test
- -40 to 70 °C operation
- ON/OFF LED indicators
- Hot swappable

Installing the FP-DO-403

The FP-DO-403 mounts on a FieldPoint terminal base (FP-TB-*x*), which provides operating power to the module. Installing the FP-DO-403 onto a powered terminal base does not disrupt the operation of the bank.

To install the FP-DO-403, refer to Figure 1 and complete the following steps:

1. Slide the terminal base key to either position X, used for any module, or position 6, used for the FP-DO-403 module.

- Align the FP-DO-403 alignment slots with the guide rails on the terminal base.
- Press firmly to seat the FP-DO-403 on the terminal base. When the module is firmly seated, the terminal base latch locks it into place.

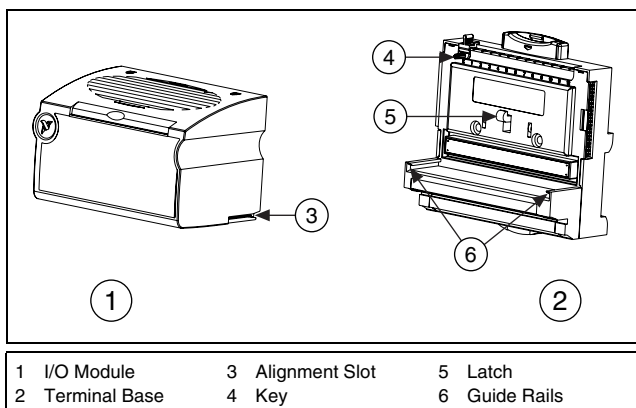

Figure 1. Installing the FP-DO-403

Installing the cFP-DO-403

The cFP-DO-403 mounts on a Compact FieldPoint backplane (cFP-BP-*x*), which provides operating power to the module. Installing the cFP-DO-403 onto a powered backplane does not disrupt the operation of the bank.

To install the cFP-DO-403, refer to Figure 2 and complete the following steps:

- Align the captive screws on the cFP-DO-403 with the screw holes on the backplane. The alignment keys on the cFP-DO-403 prevent backward insertion.
- Press firmly to seat the cFP-DO-403 on the backplane.
- Using a number 2 Phillips screwdriver with a shank of at least 64 mm (2.5 in.) length, tighten the captive screws to 1.1 N · m (10 lb · in.) of torque. The nylon coating on the screws prevents them from loosening.

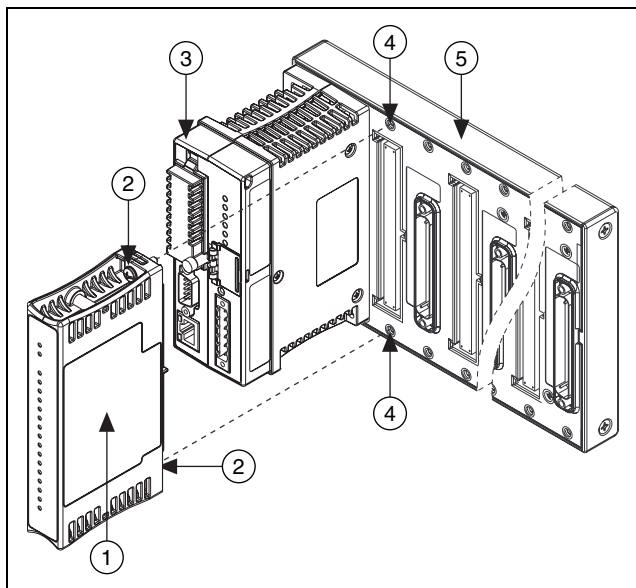

- | | |
|-------------------------|-----------------|
| 1 cFP I/O Module | 4 Screw Holes |
| 2 Captive Screws | 5 cFP Backplane |
| 3 cFP Controller Module | |

Figure 2. Installing the cFP-DO-403

Wiring the [c]FP-DO-403

The FP-TB-*x* terminal base has connections for each FP-DO-403 output channel and for an external supply to power field devices. The cFP-CB-*x* connector block provides the same connections for the cFP-DO-403.

Each channel has one output terminal, V_{out} . The output channels share eight V_{sup} terminals and eight COM terminals. All of the channels are referenced to the COM terminals. The V and V_{sup} terminals are all internally connected, as are the C and COM terminals.

Table 1 lists the terminal assignments for the signals associated with each channel. Terminal assignments and wiring diagrams are also listed on the side panel of the cFP-DO-403 and under the slide-in card on the front of the FP-DO-403 module.

Table 1. Terminal Assignments

Channel	Terminal Numbers		
	V _{out}	V _{sup}	COM
0	1	17	18
1	2	17	18
2	3	19	20
3	4	19	20
4	5	21	22
5	6	21	22
6	7	23	24
7	8	23	24

Channel	Terminal Numbers		
	V _{out}	V _{sup}	COM
8	9	25	26
9	10	25	26
10	11	27	28
11	12	27	28
12	13	29	30
13	14	29	30
14	15	31	32
15	16	31	32

National Instruments recommends that you wire the external power supply to multiple V_{sup} and COM terminals. Figure 3 shows how to connect two output channels to loads.

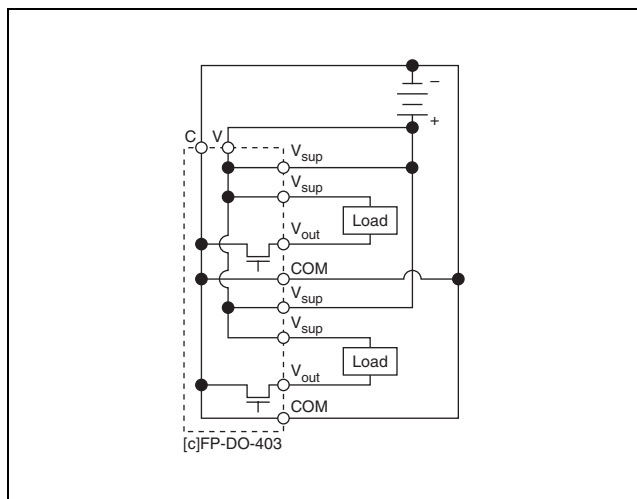

Figure 3. Recommended Field Connections

Digital Output Circuit

The [c]FP-DO-403 digital output channels are optically isolated from the rest of the FieldPoint bank. In the ON state, a transistor is turned on between the V_{out} terminal and the external supply (the C and COM terminals). In the OFF state, this transistor is turned off, allowing only a small leakage current to flow. The V_{out} terminal sinks current from external devices. Sinking current means the V_{out} terminal provides a path to the supply common.

Ensure that no channel sinks more than 2 A, and that the total current supplied by all channels at any time is no more than 16 A².

To determine whether the total current is within the limit, square the current on each channel and add the squares together. If the sum of all the squares is less than or equal to 16 A², the total current is within the limit. In the following example, three channels sink 2 A and four channels sink 1 A each:

$$(2 \text{ A})^2 + (2 \text{ A})^2 + (2 \text{ A})^2 + (1 \text{ A})^2 \\ + (1 \text{ A})^2 + (1 \text{ A})^2 + (1 \text{ A})^2 \leq 16 \text{ A}^2$$



Caution The outputs must *not* be short-circuited to the potential of the V or V_{sup} terminals (the positive voltage of the external supply). Short circuits damage the [c]FP-DO-403 output channels. Check all wiring carefully before applying power.

In the ON state, there is an effective resistance of 0.12 Ω between the output (V_{out}) and the supply voltage (the C and COM terminals). This resistance causes a voltage drop between the external supply voltage and the output voltage. For example, if the external supply voltage is 5 V and the output current is 1 A, the output voltage is 4.88 V:

$$5 \text{ V} - 1 \text{ A} \times 0.12 \text{ } \Omega = 4.88 \text{ V}$$

Protection for Inductive Loads

When an inductive load, such as a motor or relay, is connected to an output, a large counter-electromotive force may occur at switching time because of the energy stored in the inductive load. This flyback voltage can damage the outputs and the power supply.

It is best to limit such flyback voltages at the inductive load by installing a flyback diode across the load. Typically, you should

mount the flyback diode within 18 in. of the load. Figure 4 shows one channel connected to an external device with a flyback diode.

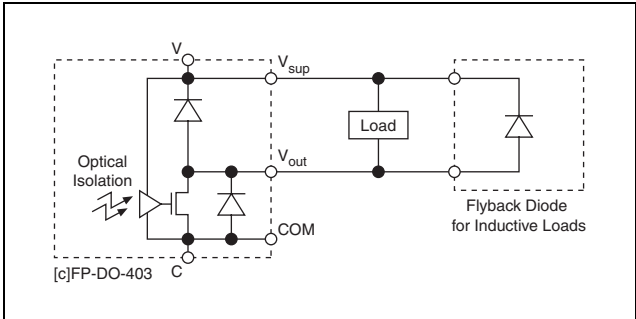

Figure 4. Connection to Inductive Load with Flyback Diode

Although the [c]FP-DO-403 contains flyback diodes to prevent excessively high voltage from damaging the module, National Instruments recommends the use of an external protection circuit across any inductive load.

Status Indicators

The [c]FP-DO-403 has two green status LEDs, **POWER** and **READY**. After you insert the FP-DO-403 into a terminal base or the cFP-DO-403 into a backplane and apply power to the connected network module, the green **POWER** indicator lights and the [c]FP-DO-403 informs the network module of its presence. When the network module recognizes the [c]FP-DO-403, it sends initial configuration information to the [c]FP-DO-403. After the module receives this initial information, the green **READY** indicator lights and the [c]FP-DO-403 is in normal operating mode.

In addition to the green **POWER** and **READY** indicators, each channel has a numbered, green output state indicator, which lights when the channel is in the ON state.

Isolation and Safety Guidelines



Caution Read the following information before attempting to connect the [c]FP-DO-403 to any circuits that may contain hazardous voltages.

This section describes the isolation of the [c]FP-DO-403 and its compliance with international safety standards. The field wiring connections are isolated from the backplane and the inter-module communication bus. The isolation barriers in the module provide 250 V_{rms} Measurement Category II continuous isolation, verified by 2,300 V_{rms}, 5 s dielectric withstand test. The [c]FP-DO-403 provides *double insulation* (compliant with IEC 61010-1) for working voltages of 250 V_{rms}¹. Safety standards (such as those published by UL and IEC) require the use of double insulation between hazardous voltages and any human-accessible parts or circuits.

Never try to use any isolation product between human-accessible parts (such as DIN rails or monitoring stations) and circuits that can be at hazardous potentials under normal conditions, unless the product is specifically designed for such an application, as is the [c]FP-DO-403.

Even though the [c]FP-DO-403 is designed to handle applications with hazardous potentials, follow these guidelines to ensure a safe total system:

- There is no isolation between channels on the [c]FP-DO-403. If a hazardous voltage is present on any channel, all channels are considered hazardous. Make sure that all other devices and circuits connected to the module are properly insulated from human contact.
- Do *not* share the external supply voltages (the V and C terminals) with other devices (including other FieldPoint devices), unless those devices are isolated from human contact.
- For Compact FieldPoint, you *must* connect the protective earth (PE) ground terminal on the cFP-BP-*x* backplane to the system safety ground. The backplane PE ground terminal has the following symbol stamped beside it: . Connect the backplane PE ground terminal to the system safety ground

¹ Working voltage is defined as the signal voltage plus the common-mode voltage. Common-mode voltage is the voltage of the module with respect to ground.

using 14 AWG (1.6 mm) wire with a ring lug. Use the 5/16 in. panhead screw shipped with the backplane to secure the ring lug to the backplane PE ground terminal.

- As with any hazardous voltage wiring, make sure that all wiring and connections meet applicable electrical codes and commonsense practices. Mount terminal bases and backplanes in an area, position, or cabinet that prevents accidental or unauthorized access to wiring that carries hazardous voltages.
- Do *not* use the [c]FP-DO-403 as the only isolating barrier between human contact and working voltages higher than 250 V_{rms}.
- Operate the [c]FP-DO-403 only at or below Pollution Degree 2. Pollution Degree 2 means that only nonconductive pollution occurs in most cases. Occasionally, however, a temporary conductivity caused by condensation must be expected.
- Operate the [c]FP-DO-403 at or below Measurement Category II. Measurement Category II is for measurements performed on circuits directly connected to the low-voltage installation. This category refers to local-level distribution, such as that provided by a standard wall outlet.

Safety Guidelines for Hazardous Locations

The [c]FP-DO-403 is suitable for use in Class I, Division 2, Groups A, B, C, D, T4 hazardous locations; Class I, Zone 2, AEx nA IIC T4 and Ex nA IIC T4 hazardous locations; and nonhazardous locations only. Follow these guidelines if you are installing the [c]FP-DO-403 in a potentially explosive environment. Failing to follow these guidelines may result in serious injury or death.



Caution Make sure that all products you use in hazardous locations are certified for such use. Refer to the product label or visit ni.com/certification, search by model number or product line, and click the appropriate link in the Certification column.



Caution Do *not* disconnect I/O-side wires or connectors unless power has been switched off or the area is known to be nonhazardous.



Caution Do *not* remove modules unless power has been switched off or the area is known to be nonhazardous.



Caution Substitution of components may impair suitability for Class I, Division 2.



Caution For Zone 2 applications, install the FieldPoint system in an enclosure rated to at least IP 54 as defined by IEC 60529 and EN 60529.



Caution For Zone 2 applications, install a protection device across the external power supply and the COM terminal. The device must prevent the external power supply voltage from exceeding 42 V if there is a transient overvoltage condition.

Special Conditions for Hazardous Locations Use in Europe

The [c]FP-DO-403 has been evaluated as EEx nC IIC T4 equipment under DEMKO Certificate No. 03 ATEX 0251502X. Each module is marked Ex II 3G and is suitable for use in Zone 2 hazardous locations.

Specifications

These specifications are typical for -40 to 70 °C unless otherwise noted. Specifications are subject to change without notice.

Output Characteristics

Number of channels	16
Output type	Sinking
Voltage range	5 to 30 VDC
Output impedance	0.12 Ω (0.12 V drop at 1 A)
Maximum current	
Per channel	2 A
All channels	16 A ²
Maximum OFF state leakage	50 μ A
Output delay time	50 μ s

Physical Characteristics

Indicators Green **POWER** and **READY** indicators, 16 green output state indicators

Weight

FP-DO-403 140 g (4.8 oz)

cFP-DO-403 110 g (3.7 oz)

Power Requirements

Power from network module 600 mW

Isolation Voltage

Channel-to-ground isolation

Continuous 250 V_{rms}, Measurement Category II

Dielectric withstand..... 2,300 V_{rms}, 5 s

Channel-to-channel isolation None

Environmental

FieldPoint modules are intended for indoor use only. For outdoor use, they must be mounted inside a sealed enclosure.

Operating temperature

Input voltage ≤ 25 V -40 to 70 °C

Input voltage ≤ 30 V -40 to 50 °C

Storage temperature -45 to 85 °C

Humidity 10 to 90% RH, noncondensing

Maximum altitude..... 2,000 m; at higher altitudes the isolation voltage ratings must be lowered

Pollution Degree 2

Shock and Vibration

These specifications apply only to the cFP-DO-403. NI recommends Compact FieldPoint if your application is subject to shock and vibration.

Operating vibration, random (IEC 60068-2-64).....	10–500 Hz, 5 g _{rms}
Operating vibration, sinusoidal (IEC 60068-2-6).....	10–500 Hz, 5 g
Operating shock (IEC 60068-2-27).....	50 g, 3 ms half sine, 18 shocks at 6 orientations; 30 g, 11 ms half sine, 18 shocks at 6 orientations

Safety

This product is designed to meet the requirements of the following standards of safety for electrical equipment for measurement, control, and laboratory use:

- IEC 61010-1, EN-61010-1
- UL 61010-1, CAN/CSA-C22.2 No. 61010-1



Note For UL and other safety certifications, refer to the product label or visit ni.com/certification, search by model number or product line, and click the appropriate link in the Certification column.

Electromagnetic Compatibility

This product is designed to meet the requirements of the following standards of EMC for electrical equipment for measurement, control, and laboratory use:

- EN 61326 EMC requirements; Industrial Immunity
- EN 55011 Emissions; Group 1, Class A
- CE, C-Tick, ICES, and FCC Part 15 Emissions; Class A

CE Compliance

This product meets the essential requirements of applicable European Directives, as amended for CE marking, as follows:

- 73/23/EEC; Low-Voltage Directive (safety)
- 89/336/EEC; Electromagnetic Compatibility Directive (EMC)



Note Refer to the Declaration of Conformity (DoC) for this product for any additional regulatory compliance information. To obtain the DoC for this product, visit ni.com/certification, search by model number or product line, and click the appropriate link in the Certification column.

Waste Electrical and Electronic Equipment (WEEE)



EU Customers At the end of their life cycle, all products *must* be sent to a WEEE recycling center. For more information about WEEE recycling centers and National Instruments WEEE initiatives, visit ni.com/environment/weee.htm.

Mechanical Dimensions

Figure 5 shows the mechanical dimensions of the FP-DO-403 installed on a terminal base. Dimensions are given in millimeters [inches]. If you are using the cFP-DO-403, refer to the Compact FieldPoint controller user manual for the dimensions and cabling clearance requirements of the Compact FieldPoint system.

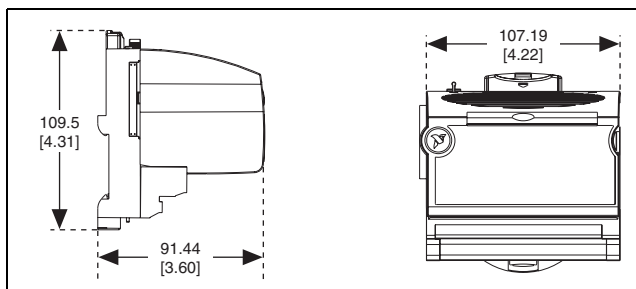

Figure 5. FP-DO-403 Mechanical Dimensions

Where to Go for Support

For more information about setting up the FieldPoint system, refer to these National Instruments documents:

- FieldPoint network module user manual
- Other FieldPoint I/O module operating instructions
- FieldPoint terminal base and connector block operating instructions

Go to ni.com/support for the most current manuals, examples, and troubleshooting information.

National Instruments corporate headquarters is located at 11500 North Mopac Expressway, Austin, Texas, 78759-3504. National Instruments also has offices located around the world to help address your support needs. For telephone support in the United States, create your service request at ni.com/support and follow the calling instructions or dial 512 795 8248. For telephone support outside the United States, contact your local branch office:

Australia 1800 300 800, Austria 43 0 662 45 79 90 0,
Belgium 32 0 2 757 00 20, Brazil 55 11 3262 3599,
Canada 800 433 3488, China 86 21 6555 7838,
Czech Republic 420 224 235 774, Denmark 45 45 76 26 00,
Finland 385 0 9 725 725 11, France 33 0 1 48 14 24 24,
Germany 49 0 89 741 31 30, India 91 80 41190000,
Israel 972 0 3 6393737, Italy 39 02 413091,
Japan 81 3 5472 2970, Korea 82 02 3451 3400,
Lebanon 961 0 1 33 28 28, Malaysia 1800 887710,
Mexico 01 800 010 0793, Netherlands 31 0 348 433 466,
New Zealand 0800 553 322, Norway 47 0 66 90 76 60,
Poland 48 22 3390150, Portugal 351 210 311 210,
Russia 7 095 783 68 51, Singapore 1800 226 5886,
Slovenia 386 3 425 4200, South Africa 27 0 11 805 8197,
Spain 34 91 640 0085, Sweden 46 0 8 587 895 00,
Switzerland 41 56 200 51 51, Taiwan 886 02 2377 2222,
Thailand 662 278 6777, United Kingdom 44 0 1635 523545

National Instruments, NI, ni.com, and LabVIEW are trademarks of National Instruments Corporation. Refer to the *Terms of Use* section on ni.com/legal for more information about National Instruments trademarks. Other product and company names mentioned herein are trademarks or trade names of their respective companies. For patents covering National Instruments products, refer to the appropriate location: **Help»Patents** in your software, the `patents.txt` file on your CD, or ni.com/patents.

© 2002–2006 National Instruments Corp. All rights reserved.