

# NI 9235/9236 Calibration Procedure

Français    Deutsch    日本語    한국어    简体中文

[ni.com/manuals](http://ni.com/manuals)

This document contains information about calibrating National Instruments 9235/9236 modules using NI-DAQmx. This calibration procedure is intended for metrology labs.

This document does not discuss programming techniques or compiler configuration. The NI-DAQmx driver contains online help files that have compiler-specific instructions and detailed function explanations. You can install these help files when you install NI-DAQmx on the calibration computer.

## Contents

---

Conventions .....	2
Software .....	2
Documentation .....	3
Calibration Interval .....	3
Test Equipment .....	4
Test Conditions .....	4
Calibration Procedure .....	5
Calibration Process Overview .....	5
Initial Setup .....	5
Connecting the Calibrator to the Module .....	6
Verification Procedures .....	8
Measurement Accuracy Verification .....	8
Shunt Calibration Accuracy Verification .....	12
Excitation Voltage Verification .....	16
Specifications .....	17
Test Limits .....	18
Calibrator Output .....	18
Nominal Value .....	18
1-Year Limits .....	18
Where to Go for Support.....	20

# Conventions

---

The following conventions appear in this manual:

» The » symbol leads you through nested menu items and dialog box options to a final action. The sequence **File»Page Setup»Options** directs you to pull down the **File** menu, select the **Page Setup** item, and select **Options** from the last dialog box.



This icon denotes a note, which alerts you to important information.

**bold** Bold text denotes items that you must select or click in the software, such as menu items and dialog box options. Bold text also denotes parameter names and hardware labels.

*italic* Italic text denotes variables, emphasis, a cross-reference, or an introduction to a key concept. Italic text also denotes text that is a placeholder for a word or value that you must supply.

monospace Monospace text denotes text or characters that you should enter from the keyboard, sections of code, programming examples, and syntax examples. This font is also used for the proper names of disk drives, paths, directories, programs, subprograms, subroutines, device names, functions, operations, variables, filenames, and extensions.

*monospace italic* Italic text in this font denotes text that is a placeholder for a word or value that you must supply.

## Software

---

Install NI-DAQmx 8.8 or later on the calibration computer. NI-DAQmx includes high-level function calls to simplify the task of writing software to calibrate devices. You must have the proper device driver installed on the calibration system before calibrating the device.



**Note** NI recommends that you install the NI-DAQmx driver software before physically installing the NI 9235/9236. NI-DAQmx, available at [ni.com/downloads](http://ni.com/downloads), configures and controls the NI 9235/9236.

NI-DAQmx supports a number of programming languages, including LabVIEW, LabWindows™/CVI™, Microsoft Visual C++ 6.0, Microsoft Visual Basic 6.0, Microsoft .NET, and Borland C++.

You can access the NI-DAQmx header file, `NIDAQmx.h`, like any standard library. You can find examples of how to use the NI-DAQmx driver in the `Program Files\National Instruments\NI-DAQ\Examples` directory.

# Documentation

---

You might find the following documentation helpful as you write the calibration procedure:

- *NI-DAQmx Help*—This help file contains general information about measurement concepts, key NI-DAQmx concepts, and common applications that apply to all programming environments. To access this help file, select **Start»All Programs»National Instruments»NI-DAQ»NI-DAQmx Help**.
- *NI-DAQmx C Reference Help*—This help file contains C reference and general information about measurement concepts. To access this help file, select **Start»All Programs»National Instruments»NI-DAQ»NI-DAQmx C Reference Help**.
- *DAQ Getting Started* guides for NI-DAQ 8.0 or later—This guide describes how to install NI-DAQmx for Windows software and NI-DAQmx-supported DAQ devices, and how to confirm that your device is operating properly. To access this guide, select **Start»All Programs»National Instruments»NI-DAQ»DAQ Getting Started Guide**.



**Note** The documents above are installed with NI-DAQmx. You can also download the latest versions from the NI Web site at [ni.com/manuals](http://ni.com/manuals).

- *NI 9235/9236 Operating Instructions and Specifications*—This document describes how to use the NI 9235/9236 and includes specifications and terminal assignments for the NI 9235/9236. The limits you use to verify the accuracy of the devices are based on the specifications found in this document. You can download the latest version of this document from the NI Web site at [ni.com/manuals](http://ni.com/manuals).

## Calibration Interval

---

The NI 9235/9236 should be calibrated at a regular interval as defined by the measurement accuracy requirements of your application. National Instruments recommends that you routinely perform a complete calibration at least once every year. You can shorten this interval based on the accuracy demands of your application or requirements of your processes.

# Test Equipment

---

National Instruments recommends that you use the following equipment for calibrating the NI 9235/9236.

**Table 1.** Recommended Equipment

Equipment	Recommended Model	Requirements
Calibrator	Fluke 5500A	If this instrument is unavailable, use a calibrator with generation of resistances in the ranges of 108 $\Omega$ – 132 $\Omega$ and 315 $\Omega$ – 385 $\Omega$ with 0.01 $\Omega$ resolution, an accuracy of at least 90 ppm, and automatic lead wire compensation.
DMM	NI 4070	If this instrument is unavailable, use a multi-ranging 6 1/2 digit DMM with an accuracy of at least 40 ppm.
Chassis	NI cDAQ chassis	—
Connecting wires	—	Connections between the module and the calibrator are insensitive to connection resistance except between the calibrator LO terminal and the module RC terminal. The resistance of this connection must be less than 200 m $\Omega$ to limit bridge linearity errors. The verification test limits in Tables 5 and 6 assume this requirement is met.

## Test Conditions

---

Follow these guidelines to optimize the connections and the environment:

- Keep connections to the device as short as possible. Long cables and wires act as antennae, picking up extra noise that can affect measurements.
- Use shielded copper wire for all cable connections to the device. Use twisted-pair wire to eliminate noise and thermal offsets.
- Maintain an ambient temperature of 23  $\pm$ 5  $^{\circ}$ C. The device temperature will be greater than the ambient temperature.
- Keep relative humidity below 80%.
- Allow a warm-up time of at least 10 minutes to ensure that the measurement circuitry is at a stable operating temperature.

# Calibration Procedure

---

This section provides instructions for verifying the performance of the NI 9235/9236.

## Calibration Process Overview

The calibration process consists of the following steps:

1. *Initial Setup*—Configure the device in NI-DAQmx.
2. *Verification Procedures*—Verify the existing operation of the device. This step confirms whether the device is operating within its specified range and whether it needs adjustment.
3. *Adjustment*—If the device does not fall within the desired specifications, submit the device to NI for a factory calibration to adjust the calibration constants.
4. *Verification Procedures*—Perform another verification to ensure that the device operates within its specifications after adjustment.

The first two steps are explained in the following sections.

## Initial Setup

You must configure the device in Measurement & Automation Explorer (MAX) to communicate with NI-DAQmx.

Complete the following steps to configure a device in MAX:

1. Install the NI-DAQmx driver software.
2. Make sure that no power is connected to the module terminals. If the system is in a nonhazardous location, the chassis power can be on when you install the module.
3. Insert the module into an available slot in the cDAQ chassis.
4. Launch MAX.
5. Right-click the device name and select **Self-Test** to ensure that the device is working properly.



**Note** When a device is configured with MAX, it is assigned a device name. Each function call uses this device name to determine which DAQ device to calibrate. This document uses `dev1` to refer to the device name. In the following procedures, use the device name as it appears in MAX.

## Connecting the Calibrator to the Module

Complete the following steps to connect the calibrator to the module for both the measurement accuracy verification and the shunt calibration verification:

1. Set the calibrator to standby mode (STBY).
2. Connect the AUX LO terminal of the calibrator to the LO terminal of the calibrator.
3. Using discrete connections, connect the LO terminal of the calibrator to the AI and RC terminals of the module channel you want to verify. Leave all other channels unconnected.



**Note** The three connections to the calibrator LO terminal must be connected at the calibrator output jack.



**Note** Ensure that the connection resistance between the calibrator LO terminal and the module RC terminal meets the requirement listed in Table 1.

4. Connect the HI terminal of the calibrator to the EXC0 terminal of the module.
5. Connect the AUX HI terminal of the calibrator to the EXC1 terminal of the module.



**Note** You do not have to change the EXC terminal connections for each channel you verify, because the EXC terminals all connect to a common excitation supply inside the NI 9235/9236.

Refer to Figure 1 for an illustration of the calibrator to module connections.

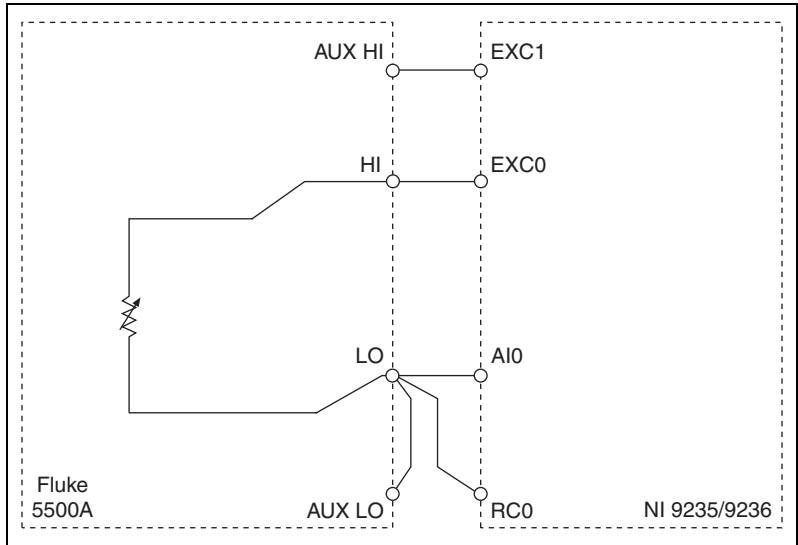

**Figure 1.** Calibrator to Module Connections

Refer to Figure 2 for the terminal assignments of the NI 9235/9236.

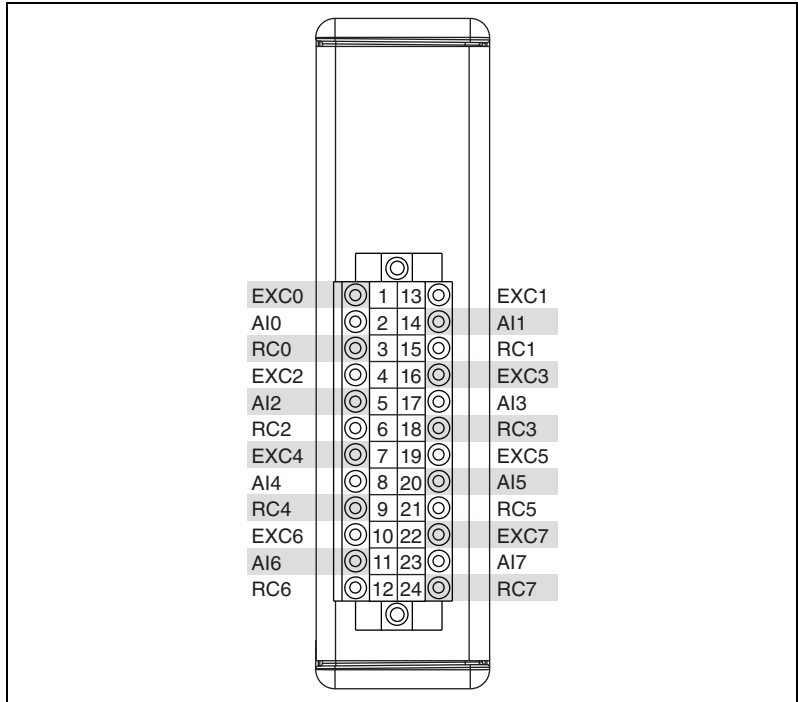

**Figure 2.** NI 9235/9236 Terminal Assignments

6. Set the calibrator resistance output to 120  $\Omega$  for the NI 9235 or 350  $\Omega$  for the NI 9236.
7. Set the calibrator to operate mode (OPR).
8. Wait one minute to allow the bridge elements formed by the calibrator and the module completion resistor to thermally stabilize.

## Verification Procedures

Verification determines how well the device is meeting its specifications. By completing this procedure, you can see how the device has drifted over time, which helps you determine the appropriate calibration interval for your application. The NI 9235/9236 has eight independent analog input channels. You can conduct verification on any or all of them, depending upon your desired test coverage.

You can verify the following for NI 9235/9236 modules:

- measurement accuracy
- shunt calibration accuracy
- excitation voltage

## Measurement Accuracy Verification

Complete the following steps to test the measurement accuracy of the device:

1. Zero the calibrator with the ohms-only zero (OHMS ZERO) operation. Refer to the calibrator documentation for more information about zeroing the calibrator.
2. Set the calibrator output for two-wire compensation (COMP 2-wire). This automatically compensates for the lead wire resistance between the HI terminal of the calibrator and the EXC terminal of the module.
3. Connect the calibrator to the channel you want to verify, as explained in the [Connecting the Calibrator to the Module](#) section.
4. Set the calibrator resistance output to a Calibrator Output value indicated in Table 5 for the NI 9235 and Table 6 for the NI 9236, beginning with the 0 V/V nominal value.



- If you use C function calls, create a task using `DAQmxCreateTask`, as shown in the following table. If you use LabVIEW, skip this step. The task is created in step 6 in LabVIEW.

LabVIEW Block Diagram	NI-DAQmx Function Call
<p style="text-align: center;">LabVIEW does not require this step.</p>	<p>Call <code>DAQmxCreateTask</code> with the following parameters:</p> <p><b>taskName:</b> <code>AIVerificationTask</code></p> <p><b>taskHandle:</b> <code>&amp;taskHandle</code></p>

- Create and configure an AI Custom Voltage with Excitation channel using the DAQmx Create Virtual Channel VI, as shown in the following table.



**Note** Throughout the procedure, refer to the NI-DAQmx function parameters for the LabVIEW input values. Refer to the block diagram images for the correct instance to use for polymorphic VIs.

LabVIEW Block Diagram	NI-DAQmx Function Call
	<p>Call <code>DAQmxCreateAIVoltageChanWithExcit</code> with the following parameters:</p> <p><b>taskHandle:</b> <code>taskHandle</code></p> <p><b>physicalChannel:</b> <code>dev1/aix*</code></p> <p><b>nameToAssignToChannel:</b> <code>myVoltageChannel</code></p> <p><b>terminalConfig:</b> <code>DAQmx_Val_Cfg_Default</code></p> <p><b>minVal:</b> <code>-0.027</code></p> <p><b>maxVal:</b> <code>0.027</code></p> <p><b>units:</b> <code>DAQmx_Val_Volts</code></p> <p><b>bridgeConfig:</b> <code>DAQmx_Val_QuarterBridge</code></p> <p><b>voltageExcitSource:</b> <code>DAQmx_Val_Internal</code></p> <p><b>voltageExcitVal:</b> <code>2.0</code> for the NI 9235 <code>3.3</code> for the NI 9236</p> <p><b>useExcitforScaling:</b> <code>TRUE</code></p> <p><b>customScaleName:</b> <code>NULL</code></p>
<p>* x refers to the channel number.</p>	

- Configure the timing properties for the acquisition using the DAQmx Timing VI, as shown in the following table.

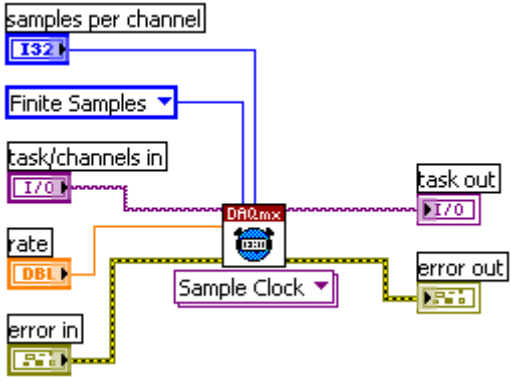
LabVIEW Block Diagram	NI-DAQmx Function Call
	<p>Call DAQmxCfgSampClkTiming with the following parameters:</p> <p><b>taskHandle:</b> taskHandle  <b>source:</b> NULL  <b>rate:</b> 5000  <b>sampleMode:</b> DAQmx_Val_FiniteSamps  <b>sampsPerChan:</b> 5000</p>

- Turn off the shunt calibration for the channel using the DAQmx Channel Property Node, as shown in the following table.

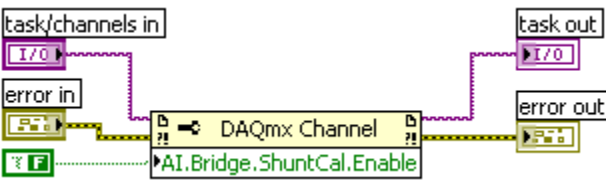
LabVIEW Block Diagram	NI-DAQmx Function Call
	<p>Call DAQmxSetAIBridgeShuntCalEnable with the following parameters:</p> <p><b>taskHandle:</b> taskHandle  <b>channel:</b> NULL  <b>data:</b> FALSE</p>

- Start the acquisition using the DAQmx Start Task VI, as shown in the following table.

LabVIEW Block Diagram	NI-DAQmx Function Call
	<p>Call DAQmxStartTask with the following parameter:</p> <p><b>taskHandle:</b> taskHandle</p>

10. Acquire 5,000 points of data using the DAQmx Read VI, as shown in the following table.

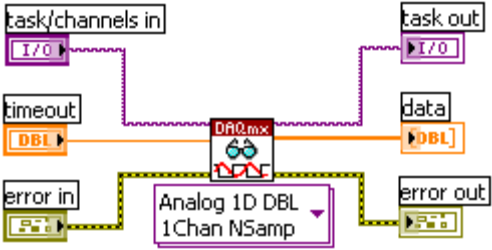
LabVIEW Block Diagram	NI-DAQmx Function Call
 <p>The diagram shows a DAQmx Read VI block. It has three input terminals: 'task/channels in' (I/O), 'timeout' (DBL), and 'error in' (Error). It has three output terminals: 'task out' (I/O), 'data' (DBL), and 'error out' (Error). A dropdown menu is set to 'Analog 1D DBL 1Chan NSamp'.</p>	<p>Call DAQmxReadAnalogF64 with the following parameters:</p> <p><b>taskHandle:</b> taskHandle  <b>numSampsPerChan:</b> -1  <b>timeout:</b> 10.0  <b>fillMode:</b> DAQmx_Val_GroupByChannel  <b>readArray:</b> data  <b>arraySizeInSamples:</b> 5000  <b>sampsPerChanRead:</b> &amp;read  <b>reserved:</b> NULL</p>

11. Average the readings that you acquired and record the result.  
 12. Clear the acquisition using the DAQmx Clear Task VI, as shown in the following table.

LabVIEW Block Diagram	NI-DAQmx Function Call
 <p>The diagram shows a DAQmx Clear Task VI block. It has two input terminals: 'task in' (I/O) and 'error in' (Error). It has one output terminal: 'error out' (Error).</p>	<p>Call DAQmxClearTask with the following parameter:</p> <p><b>taskHandle:</b> taskHandle</p>

13. Repeat steps 4 through 12 for all calibrator output values.  
 NI recommends that you verify all values, although you can save time by verifying only the values used in your application.  
 14. Perform the following calculation for each test result value other than 0 V/V, using the results you recorded in step 11.

$$\text{Test Result} - 0 \text{ V/V Test Result}$$

15. Compare the compensated result for each value to the Upper Limit (V/V) and Lower Limit (V/V) values in Table 5 for the NI 9235 and Table 6 for the NI 9236. If the result is between these values, the device passes the test.



**Note** You can analyze data in V/V form or convert it to strain using the standard quarter-bridge equation:

$$\text{strain } (\epsilon) = \frac{-4 \times V_r}{GF (1 + (2 \times V_r))}$$

where  $V_r$  is the compensated reading from the NI 9235/9236 and  $GF$  is a gage factor of 2.

16. Repeat steps 3 through 15 for all channels.
17. Set the calibrator to standby mode (STBY).
18. Disconnect the calibrator from the device.

## Shunt Calibration Accuracy Verification

Complete the following steps to test the shunt calibration accuracy of the device:

1. Using the DMM and 4-wire resistance measurement connections, measure the resistance of the wire to be connected between the calibrator LO terminal and the module RC terminal, and record the result for later use. You must do this because this connection to the module creates a lead wire desensitization error. This results in module readings that are systematically lower than the true shunt calibration output. Knowing the actual resistance value, however, allows for compensation of this effect.
2. Set the calibrator output for two-wire compensation (COMP 2-wire). This automatically compensates for the lead wire resistance between the HI terminal of the calibrator and the EXC terminal of the module.
3. Connect the calibrator to the channel you want to verify, as explained in the [Connecting the Calibrator to the Module](#) section.
4. Set the calibrator resistance output to 120  $\Omega$  for the NI 9235 or 350  $\Omega$  for the NI 9236.

- If you use C function calls, create a task using `DAQmxCreateTask`, as shown in the following table. If you use LabVIEW, skip this step. The task is created in step 6 in LabVIEW.

LabVIEW Block Diagram	NI-DAQmx Function Call
LabVIEW does not require this step.	Call <code>DAQmxCreateTask</code> with the following parameters: <b>taskName:</b> <code>SCVerificationTask</code> <b>taskHandle:</b> <code>&amp;taskHandle</code>

- Create and configure an AI Custom Voltage with Excitation channel using the DAQmx Create Virtual Channel VI, as shown in the following table.



**Note** Throughout the procedure, refer to the NI-DAQmx function parameters for the LabVIEW input values. Refer to the block diagram images for the correct instance to use for polymorphic VIs.

LabVIEW Block Diagram	NI-DAQmx Function Call
	<p>Call <code>DAQmxCreateAIVoltageChanWithExcit</code> with the following parameters:</p> <p><b>taskHandle:</b> <code>taskHandle</code>  <b>physicalChannel:</b> <code>dev1/aix*</code>  <b>nameToAssignToChannel:</b> <code>myVoltageChannel</code>  <b>terminalConfig:</b> <code>DAQmx_Val_Cfg_Default</code>  <b>minVal:</b> <code>-0.027</code>  <b>maxVal:</b> <code>0.027</code>  <b>units:</b> <code>DAQmx_Val_Volts</code>  <b>bridgeConfig:</b> <code>DAQmx_Val_QuarterBridge</code>  <b>voltageExcitSource:</b> <code>DAQmx_Val_Internal</code>  <b>voltageExcitVal:</b> <code>2.0</code> for the NI 9235  <code>3.3</code> for the NI 9236  <b>useExcitforScaling:</b> <code>TRUE</code>  <b>customScaleName:</b> <code>NULL</code></p>
* x refers to the channel number.	

- Configure the timing properties for the acquisition using the DAQmx Timing VI, as shown in the following table.

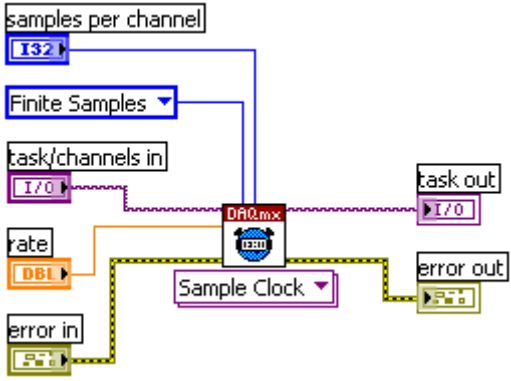
LabVIEW Block Diagram	NI-DAQmx Function Call
	<p>Call DAQmxCfgSampClkTiming with the following parameters:</p> <p><b>taskHandle:</b> taskHandle  <b>source:</b> NULL  <b>rate:</b> 5000  <b>sampleMode:</b> DAQmx_Val_FiniteSamps  <b>sampsPerChan:</b> 10000</p>

- Turn off the shunt calibration for the channel using the DAQmx Channel Property Node, as shown in the following table.

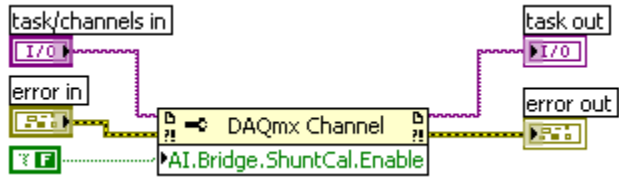
LabVIEW Block Diagram	NI-DAQmx Function Call
	<p>Call DAQmxSetAIBridgeShuntCalEnable with the following parameters:</p> <p><b>taskHandle:</b> taskHandle  <b>channel:</b> NULL  <b>data:</b> FALSE</p>

- Start the acquisition using the DAQmx Start Task VI, as shown in the following table.

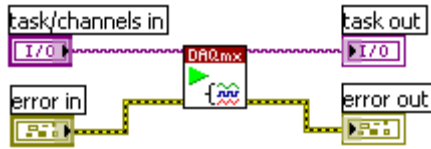
LabVIEW Block Diagram	NI-DAQmx Function Call
	<p>Call DAQmxStartTask with the following parameter:</p> <p><b>taskHandle:</b> taskHandle</p>

10. Acquire 10,000 points of data using the DAQmx Read VI, as shown in the following table.

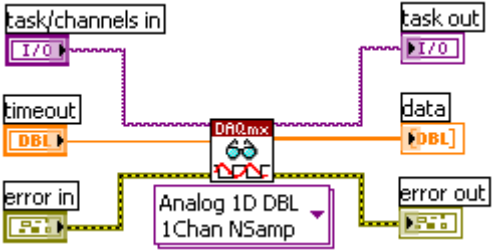
LabVIEW Block Diagram	NI-DAQmx Function Call
	<p>Call DAQmxReadAnalogF64 with the following parameters:</p> <p><b>taskHandle:</b> taskHandle  <b>numSampsPerChan:</b> -1  <b>timeout:</b> 10.0  <b>fillMode:</b>  DAQmx_Val_GroupByChannel  <b>readArray:</b> data  <b>arraySizeInSamples:</b> 10000  <b>sampsPerChanRead:</b> &amp;read  <b>reserved:</b> NULL</p>

11. Average the readings that you acquired and record the result.  
12. Clear the acquisition using the DAQmx Clear Task VI, as shown in the following table.

LabVIEW Block Diagram	NI-DAQmx Function Call
	<p>Call DAQmxClearTask with the following parameter:</p> <p><b>taskHandle:</b> taskHandle</p>

13. Repeat steps 5 through 12, but this time in step 8 set the AIBridgeShuntCalEnable property to TRUE to enable shunt calibration for the channel.  
14. Perform the following calculation using the results you recorded in step 11:

$$(Result_{SCE} - Result_{SCD}) \times (1 + R_{wire} / R_{comp})$$

where  $Result_{SCE}$  = result with shunt calibration enabled  
 $Result_{SCD}$  = result with shunt calibration disabled  
 $R_{wire}$  = wire resistance measured in step 1  
 $R_{comp}$  = 120  $\Omega$  for the NI 9235 and 350  $\Omega$  for the NI 9236

15. Compare the final result to the Upper Limit ( $\mu\text{V/V}$ ) and Lower Limit ( $\mu\text{V/V}$ ) values in Table 7. If the result is between these values, the device passes the test.



**Note** You can analyze data in  $\text{V/V}$  form or convert it to strain using the standard quarter-bridge equation:

$$\text{strain } (\epsilon) = \frac{-4 \times V_r}{GF (1 + (2 \times V_r))}$$

where  $V_r$  is the compensated reading from the NI 9235/9236 and  $GF$  is a gage factor of 2.

16. Repeat steps 3 through 15 for all channels.
17. Set the calibrator to standby mode (STBY).
18. Disconnect the calibrator from the device.

## Excitation Voltage Verification

The excitation source of the NI 9235/9236 is common to all eight input channels so you need to verify excitation voltage on only one channel.

Complete the following steps to verify the excitation voltage:

1. Connect the positive input of the DMM to any EXC terminal of the module and the negative input of the DMM to any RC terminal of the module. Leave all other terminals unconnected.
2. Measure the DC voltage and compare it to the Lower Limit and Upper Limit values in Table 8. If the result is between these values, the device passes the test.
3. Disconnect the DMM from the device.



# Specifications

---

The values in the following table are based on calibrated scaling coefficients, which are stored in the onboard EEPROM. The following calibration specifications are for  $23 \pm 5$  °C.

**Table 2.** NI 9235/9236 Measurement Accuracy

<b>Module</b>	<b>Percent of Reading (Gain Error)</b>	<b>Percent of Range* (Offset Error)</b>
NI 9235/9236	0.04% max	0.002% max
* Range equals 29.4 mV/V.		

**Table 3.** NI 9235/9236 Shunt Calibration Accuracy

<b>Module</b>	<b>Percent of Reading (Gain Error)</b>
NI 9235	0.22% max
NI 9236	0.20% max

**Table 4.** NI 9235/9236 Excitation Voltage Accuracy

<b>Module</b>	<b>Accuracy</b>
NI 9235/9236	$\pm 1\%$ max

# Test Limits

The following definitions describe how to use the information from Tables 5 through 8.

## Calibrator Output

The *Calibrator Output* is the calibrator resistance output entered for verification.

## Nominal Value

The *Nominal Value* is the approximate value that the module should read, given the corresponding calibrator output.

## 1-Year Limits

The *1-Year Limits* column contains the *Upper Limits* and *Lower Limits* for the test results. That is, when the device is within its 1-year calibration interval, the test results should fall between these upper and lower limit values.

For accuracy verification, *Upper Limits* and *Lower Limits* are given in units of V/V for verification and units of  $\mu\epsilon$  for reference.

**Table 5.** NI 9235 Measurement Accuracy Verification Test Limits

Calibrator Output ( $\Omega$ )	Nominal Value (V/V)	Nominal Value ( $\mu\epsilon$ )	1-Year Limits			
			Lower Limit (V/V)	Upper Limit (V/V)	Lower Limit ( $\mu\epsilon$ )	Upper Limit ( $\mu\epsilon$ )
120	0	0	—	—	—	—
108	0.0263158	-50,000	0.0263048	0.0263268	-49,980.1	-50,019.9
114	0.0128205	-25,000	0.0128149	0.0128261	-24,989.3	-25,010.7
117	0.0063291	-12,500	0.0063261	0.0063321	-12,494.1	-12,505.9
123	-0.0061728	12,500	-0.0061698	-0.0061758	12,493.8	12,506.0
126	-0.0121951	25,000	-0.0121897	-0.0122005	24,988.7	25,011.3
132	-0.0238095	50,000	-0.0237995	-0.0238195	49,977.8	50,022.1

**Note:** The Upper and Lower Limit (V/V) values are commonly used for verification. The Upper and Lower Limit ( $\mu\epsilon$ ) values are for reference.

**Table 6.** NI 9236 Measurement Accuracy Verification Test Limits

Calibrator Output ( $\Omega$ )	Nominal Value (V/V)	Nominal Value ( $\mu\epsilon$ )	1-Year Limits			
			Lower Limit (V/V)	Upper Limit (V/V)	Lower Limit ( $\mu\epsilon$ )	Upper Limit ( $\mu\epsilon$ )
350	0	0	—	—	—	—
315	0.0263158	-50,000	0.0263048	0.0263268	-49,980.1	-50,019.9
332.5	0.0128205	-25,000	0.0128149	0.0128261	-24,989.3	-25,010.7
341.25	0.0063291	-12,500	0.0063261	0.0063321	-12,494.1	-12,505.9
358.75	-0.0061728	12,500	-0.0061698	-0.0061758	12,493.8	12,506.0
367.5	-0.0121951	25,000	-0.0121897	-0.0122005	24,988.7	25,011.3
385	-0.0238095	50,000	-0.0237995	-0.0238195	49,977.8	50,022.1
<b>Note:</b> The Upper and Lower Limit (V/V) values are commonly used for verification. The Upper and Lower Limit ( $\mu\epsilon$ ) values are for reference.						

**Table 7.** NI 9235/9236 Shunt Calibration Accuracy Verification Test Limits

Module	Nominal Value ( $\mu\text{V/V}$ )	Nominal Value ( $\mu\epsilon$ )	1-Year Limits			
			Lower Limit ( $\mu\text{V/V}$ )	Upper Limit ( $\mu\text{V/V}$ )	Lower Limit ( $\mu\epsilon$ )	Upper Limit ( $\mu\epsilon$ )
NI 9235	-599.28	1200.0	-597.96	-600.60	1197.3	1202.7
NI 9236	-873.47	1750.0	-871.72	-875.22	1746.5	1753.5
<b>Note:</b> The Upper and Lower Limit ( $\mu\text{V/V}$ ) values are commonly used for verification. The Upper and Lower Limit ( $\mu\epsilon$ ) values are for reference.						

**Table 8.** NI 9235/9236 Excitation Voltage Verification 1-Year Test Limits

Module	Lower Limit (V)	Upper Limit (V)
NI 9235	1.980	2.020
NI 9236	3.267	3.333

# Where to Go for Support

---

The National Instruments Web site is your complete resource for technical support. At [ni.com/support](http://ni.com/support) you have access to everything from troubleshooting and application development self-help resources to email and phone assistance from NI Application Engineers.

National Instruments corporate headquarters is located at 11500 North Mopac Expressway, Austin, Texas, 78759-3504. National Instruments also has offices located around the world to help address your support needs. For telephone support in the United States, create your service request at [ni.com/support](http://ni.com/support) and follow the calling instructions or dial 512 795 8248. For telephone support outside the United States, contact your local branch office:

Australia 1800 300 800, Austria 43 662 457990-0,  
Belgium 32 (0) 2 757 0020, Brazil 55 11 3262 3599,  
Canada 800 433 3488, China 86 21 5050 9800,  
Czech Republic 420 224 235 774, Denmark 45 45 76 26 00,  
Finland 358 (0) 9 725 72511, France 01 57 66 24 24,  
Germany 49 89 7413130, India 91 80 41190000, Israel 972 3 6393737,  
Italy 39 02 41309277, Japan 0120-527196, Korea 82 02 3451 3400,  
Lebanon 961 (0) 1 33 28 28, Malaysia 1800 887710,  
Mexico 01 800 010 0793, Netherlands 31 (0) 348 433 466,  
New Zealand 0800 553 322, Norway 47 (0) 66 90 76 60,  
Poland 48 22 328 90 10, Portugal 351 210 311 210,  
Russia 7 495 783 6851, Singapore 1800 226 5886,  
Slovenia 386 3 425 42 00, South Africa 27 0 11 805 8197,  
Spain 34 91 640 0085, Sweden 46 (0) 8 587 895 00,  
Switzerland 41 56 2005151, Taiwan 886 02 2377 2222,  
Thailand 662 278 6777, Turkey 90 212 279 3031,  
United Kingdom 44 (0) 1635 523545

CVI, LabVIEW, National Instruments, NI, ni.com, the National Instruments corporate logo, and the Eagle logo are trademarks of National Instruments Corporation. Refer to the *Trademark Information* at [ni.com/trademarks](http://ni.com/trademarks) for other National Instruments trademarks. The mark LabWindows is used under a license from Microsoft Corporation. Windows is a registered trademark of Microsoft Corporation in the United States and other countries. Other product and company names mentioned herein are trademarks or trade names of their respective companies. For patents covering National Instruments products/technology, refer to the appropriate location: **Help»Patents** in your software, the `patents.txt` file on your media, or the *National Instruments Patent Notice* at [ni.com/patents](http://ni.com/patents).