

# NI 9237 Calibration Procedure

This document contains information about calibrating National Instruments 9237 modules using NI-DAQmx. This calibration procedure is intended for metrology labs.

This document does not discuss programming techniques or compiler configuration. The NI-DAQmx driver contains online help files that have compiler-specific instructions and detailed function explanations. You can install these help files when you install NI-DAQmx on the calibration computer.

## Contents

---

Conventions .....	2
Software .....	2
Documentation .....	3
Calibration Interval .....	3
Test Equipment .....	4
Test Conditions .....	4
Calibration Procedure .....	5
Calibration Process Overview .....	5
Initial Setup .....	5
Verification Procedure .....	6
Specifications .....	12
Test Limits .....	12
Using the Table .....	12
Excitation Setting Value .....	12
Calibrator Output .....	12
Range .....	12
Test Point Value .....	13
1-Year Absolute Error .....	13
Where to Go for Support.....	14

# Conventions

---

The following conventions appear in this manual:

» The » symbol leads you through nested menu items and dialog box options to a final action. The sequence **File»Page Setup»Options** directs you to pull down the **File** menu, select the **Page Setup** item, and select **Options** from the last dialog box.



This icon denotes a note, which alerts you to important information.

**bold**

Bold text denotes items that you must select or click in the software, such as menu items and dialog box options. Bold text also denotes parameter names and hardware labels.

*italic*

Italic text denotes variables, emphasis, a cross-reference, or an introduction to a key concept. Italic text also denotes text that is a placeholder for a word or value that you must supply.

monospace

Monospace text denotes text or characters that you should enter from the keyboard, sections of code, programming examples, and syntax examples. This font is also used for the proper names of disk drives, paths, directories, programs, subprograms, subroutines, device names, functions, operations, variables, filenames, and extensions.

*monospace italic*

Italic text in this font denotes text that is a placeholder for a word or value that you must supply.

## Software

---

Install NI-DAQmx 8.1 or later on the calibration computer. NI-DAQmx includes high-level function calls to simplify the task of writing software to calibrate devices. You must have the proper device driver installed on the calibration system before calibrating the device.



**Note** NI recommends that you install the NI-DAQmx driver software before physically installing the NI 9237. NI-DAQmx, available at [ni.com/downloads](http://ni.com/downloads), configures and controls the NI 9237.

NI-DAQmx supports a number of programming languages, including LabVIEW, LabWindows™/CVI™, Microsoft Visual C++ 6.0, Microsoft Visual Basic 6.0, Microsoft .NET, and Borland C++.

You can access the NI-DAQmx header file, `NIDAQmx.h`, like any standard library. You can find examples of how to use the NI-DAQmx driver in the

## Documentation

---

You might find the following documentation helpful as you write the calibration procedure:

- *NI-DAQmx Help*—This help file contains general information about measurement concepts, key NI-DAQmx concepts, and common applications that apply to all programming environments. To access this help file, select **Start»All Programs»National Instruments»NI-DAQ»NI-DAQmx Help**.
- *NI-DAQmx C Reference Help*—This help file contains C reference and general information about measurement concepts. To access this help file, select **Start»All Programs»National Instruments»NI-DAQ»NI-DAQmx C Reference Help**.
- *DAQ Getting Started Guide* for NI-DAQ 8.0 or later—This guide describes how to install NI-DAQmx for Windows software and NI-DAQmx-supported DAQ devices, and how to confirm that your device is operating properly. To access this guide, select **Start»All Programs»National Instruments»NI-DAQ»DAQ Getting Started Guide**.



**Note** The documents above are installed with NI-DAQmx. You can also download the latest versions from the NI Web site at [ni.com/manuals](http://ni.com/manuals).

- *NI 9237 Operating Instructions*—This document describes how to use the NI 9237 and includes specifications and terminal assignments for the NI 9237. You can download the latest version of this document from the NI Web site at [ni.com/manuals](http://ni.com/manuals).

## Calibration Interval

---

The NI 9237 should be calibrated at a regular interval as defined by the measurement accuracy requirements of your application. National Instruments recommends that you routinely perform a complete calibration at least once every year. You can shorten this interval based on the accuracy demands of your application or requirements of your processes. Adjusting the calibration constants must be done by a factory calibration at NI.

# Test Equipment

---

National Instruments recommends that you use the following equipment for calibrating the NI 9237.

**Table 1.** Recommended Equipment

Equipment	Recommended Model	Requirements
Calibrator	Fluke 5700A	If this instrument is unavailable, use a high-precision voltage source with an accuracy of at least 10 ppm and an output impedance of less than or equal to 50 $\Omega$ .
DMM	NI 4070 DMM	If this instrument is unavailable, use a multiranging 6 ½ digit DMM with an accuracy of at least 40 ppm.
Chassis	NI cDAQ-9172	—
Connection accessories	RJ-50, RJ-50 cable	Use an RJ-50 10-position connector plug and an RJ-50 cable.
Bridge completion accessories	NI 9949, 350 $\Omega$ resistors	Use one NI 9949 screw terminal accessory and two 350 $\Omega$ resistors with at least 1% tolerance.

## Test Conditions

---

Follow these guidelines to optimize the connections and the environment:

- Keep connections to the device as short as possible. Long cables and wires act as antennae, picking up extra noise that can affect measurements.
- Use shielded copper wire for all cable connections to the device. Use twisted-pair wire to eliminate noise and thermal offsets.
- Maintain an ambient temperature of  $23 \pm 10$  °C. The device temperature will be greater than the ambient temperature.
- Keep relative humidity below 80%.
- Allow a warm-up time of at least 10 minutes to ensure that the measurement circuitry is at a stable operating temperature.

# Calibration Procedure

---

This section provides instructions for verifying the performance of the NI 9237.

## Calibration Process Overview

The calibration process consists of the following steps:

1. *Initial Setup*—Configure the device in NI-DAQmx.
2. *Verification Procedure*—Verify the existing operation of the device. This step confirms whether the device was operating within its specified range prior to calibration.
3. *Adjustment*—Submit the device to NI for a factory calibration to adjust the calibration constants.
4. *Verification Procedure*—Perform another verification to ensure that the device operates within its specifications after adjustment.

The first two steps are explained in the following sections.

## Initial Setup

You must configure the device in Measurement & Automation Explorer (MAX) to communicate with NI-DAQmx.

Complete the following steps to configure a device in MAX.

1. Install the NI-DAQmx driver software.
2. Make sure that no power is connected to the module terminals. If the system is in a nonhazardous location, the chassis power can be on when you install the module.
3. Insert the module into an available slot in the cDAQ-9172 chassis.
4. Launch MAX.
5. Right-click the device name and select **Self-Test** to ensure that the device is working properly.



**Note** When a device is configured with MAX, it is assigned a device name. Each function call uses this device name to determine which DAQ device to calibrate. This document uses `dev1` to refer to the device name. In the following procedures, use the device name as it appears in MAX.

## Verification Procedure

Verification determines how well the device is meeting its specifications. By completing this procedure, you can see how the device has drifted over time, which helps you determine the appropriate calibration interval for your application. Table 4 in the *Test Limits* section shows all acceptable settings for the device type. Throughout the verification process, use Table 4 to determine if the device is operating within its specified range. You must perform verification on all analog input channels.

Complete the following steps to test the performance of the device.

1. Make the following connections on the NI 9949 terminal block:
  - Insert one leg of each 350  $\Omega$  resistor into AI–.
  - Insert the second leg of one 350  $\Omega$  resistor into EX+.
  - Insert the second leg of the other 350  $\Omega$  resistor into EX–.
  - Connect RS+ to EX+.
  - Connect RS– to EX–.
  - Connect the positive input of the DMM to RS+.
  - Connect the negative input of the DMM to RS–.
  - Connect the positive output of the calibrator to AI+.
  - Connect the negative output of the calibrator to AI–.
  - Leave the SC, T+, and T– terminals unconnected.
  - If the calibrator has a separate guard connection not connected to LO, connect that terminal to AI–.

Refer to Table 2 for the pin assignments and signal names of the NI 9237. Refer to Figure 1 for an illustration of the NI 9949 connections.

**Table 2.** Pin Assignments and Signal Names

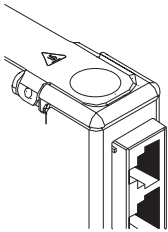
Module	RJ-50 Pin	Signal Name	Signal Description
	1	SC	Shunt calibration
	2	AI+	Positive analog input
	3	AI-	Negative analog input
	4	RS+	Positive remote sense input
	5	RS-	Negative remote sense input
	6	EX+	Positive excitation output*
	7	EX-	Negative excitation output*
	8	T+	TEDS DATA
	9	T-	TEDS Return*
	10	SC	Shunt calibration

\* These signals are shared by all four RJ-50 connectors on the NI 9237.

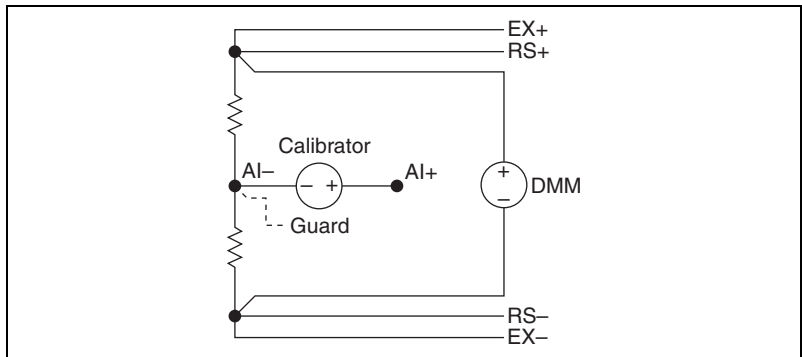

**Figure 1.** NI 9949 Connections

2. Set the calibrator voltage to the Calibrator Output value indicated in Table 4. NI recommends that you verify all values, although you can save time by verifying only the values used in your application.
3. If you use C function calls, create a task using `DAQmxCreateTask`, as shown in the following table. If you use LabVIEW, skip this step. The task is created in step 4 in LabVIEW.

LabVIEW Block Diagram	NI-DAQmx Function Call
LabVIEW does not require this step.	Call <code>DAQmxCreateTask</code> with the following parameters: <b>taskName:</b> <i>AIVerificationTask</i> <b>taskHandle:</b> <code>&amp;taskHandle</code>



4. Create and configure an AI Custom Voltage with Excitation channel using the DAQmx Create Virtual Channel VI, as shown in the following table. Use Table 4 to determine the minimum and maximum values for the device.



**Note** Throughout the procedure, refer to the NI-DAQmx function parameters for the LabVIEW input values.

LabVIEW Block Diagram	NI-DAQmx Function Call
	<p>Call  DAQmxCreateAIVoltageChan  WithExcit with the following  parameters:</p> <p><b>taskHandle:</b> taskHandle  <b>physicalChannel:</b> dev1/ai0  <b>nameToAssignToChannel:</b>  <i>myVoltageChannel</i>  <b>terminalConfig:</b>  DAQmx_Val_Cfg_Default  <b>minVal:</b> -0.025  <b>maxVal:</b> 0.025  <b>units:</b> DAQmx_Val_Volts  <b>bridgeConfig:</b>  DAQmx_Val_FullBridge  <b>voltageExcitSource:</b>  DAQmx_Val_Internal  <b>voltageExcitVal:</b>* 2.5, 3.3,  5.0, or 10.0  <b>useExcitforScaling:</b> TRUE  <b>customScaleName:</b> NULL</p>
<p>*Use the excitation value that corresponds to the calibrator voltage value you set in step 2. Refer to Table 4 for corresponding excitation setting and calibrator output values.</p>	

- Configure the timing properties for the voltage acquisition using the DAQmx Timing VI, as shown in the following table.

LabVIEW Block Diagram	NI-DAQmx Function Call
	<p>Call DAQmxCfgSampClkTiming with the following parameters:</p> <p><b>taskHandle:</b> taskHandle  <b>source:</b> NULL  <b>rate:</b> 50000  <b>activeEdge:</b> DAQmx_Val_Rising  <b>sampleMode:</b> DAQmx_Val_FiniteSamps  <b>sampsPerChan:</b> 10000</p>

- Start the acquisition using the DAQmx Start Task VI, as shown in the following table.

LabVIEW Block Diagram	NI-DAQmx Function Call
	<p>Call DAQmxStartTask with the following parameter:</p> <p><b>taskHandle:</b> taskHandle</p>

- Acquire and average 10,000 points of voltage data using the DAQmx Read VI, as shown in the following table.

LabVIEW Block Diagram	NI-DAQmx Function Call
	<p>Call DAQmxReadAnalogF64 with the following parameters:</p> <p><b>taskHandle:</b> taskHandle  <b>numSampsPerChan:</b> -1  <b>timeout:</b> 10.0  <b>fillMode:</b>  DAQmx_Val_GroupByChannel  <b>readArray:</b> data  <b>arraySizeInSamples:</b> 10000  <b>sampsPerChanRead:</b> &amp;read  <b>reserved:</b> NULL</p>

- Take a reading of the excitation value from the DMM. You must take this reading for each excitation value that you enter in step 4.
- Calculate the upper and lower limits using the following equations:
$$\text{UpperLimit} = (\text{CalibratorOutputSetting} / \text{DMMReading}) + \text{AbsoluteErrorfromTable4}$$

$$\text{LowerLimit} = (\text{CalibratorOutputSetting} / \text{DMMReading}) - \text{AbsoluteErrorfromTable4}$$
- Compare the result from step 7 to the upper limit and lower limit values you calculated in step 9. If the result is between these values, the device passes the test.
- Clear the acquisition using the DAQmx Clear Task VI, as shown in the following table.

LabVIEW Block Diagram	NI-DAQmx Function Call
	<p>Call DAQmxClearTask with the following parameter:</p> <p><b>taskHandle:</b> taskHandle</p>

- Repeat steps 2 through 11 for all voltage values, all excitation values, and all channels.
- Disconnect the calibrator and the DMM from the device.

# Specifications

---

The values in the following table are based on calibrated scaling coefficients, which are stored in the onboard EEPROM. The following calibration specifications are for  $23 \pm 10$  °C.

**Table 3.** NI 9237 Accuracy

Excitation Setting Value (V)	Gain Error	Offset Error ( $\mu\text{V}/\text{V}$ )
2.5	0.14%	32.5
3.3	0.12%	10
5.0	0.14%	27.5
10.0	0.16%	45

## Test Limits

---

Table 4 lists the specifications that the NI 9237 should meet if it has been one year between calibrations.

## Using the Table

The following definitions describe how to use the information from Table 4.

### Excitation Setting Value

The *Excitation Setting Value* is the voltage value to enter in the DAQmx Create Virtual Channel VI in step 4.

### Calibrator Output

The *Calibrator Output* is the voltage value that you source into the NI 9237 for verification purposes. This value is broken down into two columns—*Location* and *Value*. *Location* refers to where the value fits within the test range. *Value* refers to the voltage value to be verified. *Max* refers to maximum value, *Min* refers to minimum value, and *Mid* refers to mid-scale.

### Range

The *Range* is the minimum and maximum voltage range of the input signal.

## Test Point Value

The *Test Point Value* is an approximate voltage value that the NI 9237 should read given the corresponding calibrator output and excitation setting.

## 1-Year Absolute Error

The *1-Year Absolute Error* is the voltage value that you use to calculate upper and lower limits.

**Table 4.** NI 9237 Verification Test Limits

Excitation Setting Value (V)	Calibrator Output		Range (V/V)		Test Point Value (V/V)	1-Year Absolute Error (V/V)
	Location	Value (V)	Minimum	Maximum		
2.5	Max	0.055	-0.025	0.025	0.022000	0.000063
2.5	Mid	0.000	-0.025	0.025	0.000000	0.000033
2.5	Min	-0.055	-0.025	0.025	-0.022000	0.000063
3.3	Max	0.073	-0.025	0.025	0.022000	0.000036
3.3	Mid	0.000	-0.025	0.025	0.000000	0.000010
3.3	Min	-0.073	-0.025	0.025	-0.022000	0.000036
5.0	Max	0.110	-0.025	0.025	0.022000	0.000058
5.0	Mid	0.000	-0.025	0.025	0.000000	0.000028
5.0	Min	-0.110	-0.025	0.025	-0.022000	0.000058
10.0	Max	0.220	-0.025	0.025	0.022000	0.000080
10.0	Mid	0.000	-0.025	0.025	0.000000	0.000045
10.0	Min	-0.220	-0.025	0.025	-0.022000	0.000080

# Where to Go for Support

---

The National Instruments Web site is your complete resource for technical support. At [ni.com/support](http://ni.com/support) you have access to everything from troubleshooting and application development self-help resources to email and phone assistance from NI Application Engineers.

National Instruments corporate headquarters is located at 11500 North Mopac Expressway, Austin, Texas, 78759-3504. National Instruments also has offices located around the world to help address your support needs. For telephone support in the United States, create your service request at [ni.com/support](http://ni.com/support) and follow the calling instructions or dial 512 795 8248. For telephone support outside the United States, contact your local branch office:

Australia 1800 300 800, Austria 43 662 457990-0,  
Belgium 32 (0) 2 757 0020, Brazil 55 11 3262 3599,  
Canada 800 433 3488, China 86 21 5050 9800,  
Czech Republic 420 224 235 774, Denmark 45 45 76 26 00,  
Finland 385 (0) 9 725 72511, France 01 57 66 24 24,  
Germany 49 89 7413130, India 91 80 41190000, Israel 972 3 6393737,  
Italy 39 02 413091, Japan 81 3 5472 2970, Korea 82 02 3451 3400,  
Lebanon 961 (0) 1 33 28 28, Malaysia 1800 887710,  
Mexico 01 800 010 0793, Netherlands 31 (0) 348 433 466,  
New Zealand 0800 553 322, Norway 47 (0) 66 90 76 60,  
Poland 48 22 3390150, Portugal 351 210 311 210, Russia 7 495 783 6851,  
Singapore 1800 226 5886, Slovenia 386 3 425 42 00,  
South Africa 27 0 11 805 8197, Spain 34 91 640 0085,  
Sweden 46 (0) 8 587 895 00, Switzerland 41 56 2005151,  
Taiwan 886 02 2377 2222, Thailand 662 278 6777,  
Turkey 90 212 279 3031, United Kingdom 44 (0) 1635 523545

National Instruments, NI, ni.com, and LabVIEW are trademarks of National Instruments Corporation. Refer to the *Terms of Use* section on [ni.com/legal](http://ni.com/legal) for more information about National Instruments trademarks. Other product and company names mentioned herein are trademarks or trade names of their respective companies. For patents covering National Instruments products, refer to the appropriate location: **Help»Patents** in your software, the `patents.txt` file on your CD, or [ni.com/patents](http://ni.com/patents).