

NI Vision

NI PXI/PCI-1422 User Manual

High-Quality Image Acquisition Device

Worldwide Technical Support and Product Information

ni.com

National Instruments Corporate Headquarters

11500 North Mopac Expressway Austin, Texas 78759-3504 USA Tel: 512 683 0100

Worldwide Offices

Australia 1800 300 800, Austria 43 662 457990-0, Belgium 32 (0) 2 757 0020, Brazil 55 11 3262 3599,
Canada 800 433 3488, China 86 21 6555 7838, Czech Republic 420 224 235 774, Denmark 45 45 76 26 00,
Finland 385 (0) 9 725 72511, France 33 (0) 1 48 14 24 24, Germany 49 89 7413130, India 91 80 41190000,
Israel 972 3 6393737, Italy 39 02 413091, Japan 81 3 5472 2970, Korea 82 02 3451 3400,
Lebanon 961 (0) 1 33 28 28, Malaysia 1800 887710, Mexico 01 800 010 0793, Netherlands 31 (0) 348 433 466,
New Zealand 0800 553 322, Norway 47 (0) 66 90 76 60, Poland 48 22 3390150, Portugal 351 210 311 210,
Russia 7 495 783 6851, Singapore 1800 226 5886, Slovenia 386 3 425 42 00, South Africa 27 0 11 805 8197,
Spain 34 91 640 0085, Sweden 46 (0) 8 587 895 00, Switzerland 41 56 2005151, Taiwan 886 02 2377 2222,
Thailand 662 278 6777, Turkey 90 212 279 3031, United Kingdom 44 (0) 1635 523545

For further support information, refer to the *Technical Support and Professional Services* appendix. To comment on National Instruments documentation, refer to the National Instruments Web site at ni.com/info and enter the info code `feedback`.

Important Information

Warranty

The NI PXI/PCI-1411 is warranted against defects in materials and workmanship for a period of one year from the date of shipment, as evidenced by receipts or other documentation. National Instruments will, at its option, repair or replace equipment that proves to be defective during the warranty period. This warranty includes parts and labor.

The media on which you receive National Instruments software are warranted not to fail to execute programming instructions, due to defects in materials and workmanship, for a period of 90 days from date of shipment, as evidenced by receipts or other documentation. National Instruments will, at its option, repair or replace software media that do not execute programming instructions if National Instruments receives notice of such defects during the warranty period. National Instruments does not warrant that the operation of the software shall be uninterrupted or error free.

A Return Material Authorization (RMA) number must be obtained from the factory and clearly marked on the outside of the package before any equipment will be accepted for warranty work. National Instruments will pay the shipping costs of returning to the owner parts which are covered by warranty.

National Instruments believes that the information in this document is accurate. The document has been carefully reviewed for technical accuracy. In the event that technical or typographical errors exist, National Instruments reserves the right to make changes to subsequent editions of this document without prior notice to holders of this edition. The reader should consult National Instruments if errors are suspected. In no event shall National Instruments be liable for any damages arising out of or related to this document or the information contained in it.

EXCEPT AS SPECIFIED HEREIN, NATIONAL INSTRUMENTS MAKES NO WARRANTIES, EXPRESS OR IMPLIED, AND SPECIFICALLY DISCLAIMS ANY WARRANTY OF MERCHANTABILITY OR FITNESS FOR A PARTICULAR PURPOSE. CUSTOMER'S RIGHT TO RECOVER DAMAGES CAUSED BY FAULT OR NEGLIGENCE ON THE PART OF NATIONAL INSTRUMENTS SHALL BE LIMITED TO THE AMOUNT THEREOF PAID BY THE CUSTOMER. NATIONAL INSTRUMENTS WILL NOT BE LIABLE FOR DAMAGES RESULTING FROM LOSS OF DATA, PROFITS, USE OF PRODUCTS, OR INCIDENTAL OR CONSEQUENTIAL DAMAGES, EVEN IF ADVISED OF THE POSSIBILITY THEREOF. This limitation of the liability of National Instruments will apply regardless of the form of action, whether in contract or tort, including negligence. Any action against National Instruments must be brought within one year after the cause of action accrues. National Instruments shall not be liable for any delay in performance due to causes beyond its reasonable control. The warranty provided herein does not cover damages, defects, malfunctions, or service failures caused by owner's failure to follow the National Instruments installation, operation, or maintenance instructions; owner's modification of the product; owner's abuse, misuse, or negligent acts; and power failure or surges, fire, flood, accident, actions of third parties, or other events outside reasonable control.

Copyright

Under the copyright laws, this publication may not be reproduced or transmitted in any form, electronic or mechanical, including photocopying, recording, storing in an information retrieval system, or translating, in whole or in part, without the prior written consent of National Instruments Corporation.

National Instruments respects the intellectual property of others, and we ask our users to do the same. NI software is protected by copyright and other intellectual property laws. Where NI software may be used to reproduce software or other materials belonging to others, you may use NI software only to reproduce materials that you may reproduce in accordance with the terms of any applicable license or other legal restriction.

Trademarks

National Instruments, NI, ni.com, and LabVIEW are trademarks of National Instruments Corporation. Refer to the *Terms of Use* section on ni.com/legal for more information about National Instruments trademarks.

Other product and company names mentioned herein are trademarks or trade names of their respective companies.

Members of the National Instruments Alliance Partner Program are business entities independent from National Instruments and have no agency, partnership, or joint-venture relationship with National Instruments.

Patents

For patents covering National Instruments products, refer to the appropriate location: **Help»Patents** in your software, the `patents.txt` file on your CD, or ni.com/patents.

WARNING REGARDING USE OF NATIONAL INSTRUMENTS PRODUCTS

(1) NATIONAL INSTRUMENTS PRODUCTS ARE NOT DESIGNED WITH COMPONENTS AND TESTING FOR A LEVEL OF RELIABILITY SUITABLE FOR USE IN OR IN CONNECTION WITH SURGICAL IMPLANTS OR AS CRITICAL COMPONENTS IN ANY LIFE SUPPORT SYSTEMS WHOSE FAILURE TO PERFORM CAN REASONABLY BE EXPECTED TO CAUSE SIGNIFICANT INJURY TO A HUMAN.

(2) IN ANY APPLICATION, INCLUDING THE ABOVE, RELIABILITY OF OPERATION OF THE SOFTWARE PRODUCTS CAN BE IMPAIRED BY ADVERSE FACTORS, INCLUDING BUT NOT LIMITED TO FLUCTUATIONS IN ELECTRICAL POWER SUPPLY, COMPUTER HARDWARE MALFUNCTIONS, COMPUTER OPERATING SYSTEM SOFTWARE FITNESS, FITNESS OF COMPILERS AND DEVELOPMENT SOFTWARE USED TO DEVELOP AN APPLICATION, INSTALLATION ERRORS, SOFTWARE AND HARDWARE COMPATIBILITY PROBLEMS, MALFUNCTIONS OR FAILURES OF ELECTRONIC MONITORING OR CONTROL DEVICES, TRANSIENT FAILURES OF ELECTRONIC SYSTEMS (HARDWARE AND/OR SOFTWARE), UNANTICIPATED USES OR MISUSES, OR ERRORS ON THE PART OF THE USER OR APPLICATIONS DESIGNER (ADVERSE FACTORS SUCH AS THESE ARE HEREAFTER COLLECTIVELY TERMED "SYSTEM FAILURES"). ANY APPLICATION WHERE A SYSTEM FAILURE WOULD CREATE A RISK OF HARM TO PROPERTY OR PERSONS (INCLUDING THE RISK OF BODILY INJURY AND DEATH) SHOULD NOT BE RELIANT SOLELY UPON ONE FORM OF ELECTRONIC SYSTEM DUE TO THE RISK OF SYSTEM FAILURE. TO AVOID DAMAGE, INJURY, OR DEATH, THE USER OR APPLICATION DESIGNER MUST TAKE REASONABLY PRUDENT STEPS TO PROTECT AGAINST SYSTEM FAILURES, INCLUDING BUT NOT LIMITED TO BACK-UP OR SHUT DOWN MECHANISMS, BECAUSE EACH END-USER SYSTEM IS CUSTOMIZED AND DIFFERS FROM NATIONAL INSTRUMENTS' TESTING PLATFORMS AND BECAUSE A USER OR APPLICATION DESIGNER MAY USE NATIONAL INSTRUMENTS PRODUCTS IN COMBINATION WITH OTHER PRODUCTS IN A MANNER NOT EVALUATED OR CONTEMPLATED BY NATIONAL INSTRUMENTS, THE USER OR APPLICATION DESIGNER IS ULTIMATELY RESPONSIBLE FOR VERIFYING AND VALIDATING THE SUITABILITY OF NATIONAL INSTRUMENTS PRODUCTS WHENEVER NATIONAL INSTRUMENTS PRODUCTS ARE INCORPORATED IN A SYSTEM OR APPLICATION, INCLUDING, WITHOUT LIMITATION, THE APPROPRIATE DESIGN, PROCESS AND SAFETY LEVEL OF SUCH SYSTEM OR APPLICATION.

Compliance

Compliance with FCC/Canada Radio Frequency Interference Regulations

Determining FCC Class

The Federal Communications Commission (FCC) has rules to protect wireless communications from interference. The FCC places digital electronics into two classes. These classes are known as Class A (for use in industrial-commercial locations only) or Class B (for use in residential or commercial locations). All National Instruments (NI) products are FCC Class A products.

Depending on where it is operated, this Class A product could be subject to restrictions in the FCC rules. (In Canada, the Department of Communications (DOC), of Industry Canada, regulates wireless interference in much the same way.) Digital electronics emit weak signals during normal operation that can affect radio, television, or other wireless products.

All Class A products display a simple warning statement of one paragraph in length regarding interference and undesired operation. The FCC rules have restrictions regarding the locations where FCC Class A products can be operated.

Consult the FCC Web site at www.fcc.gov for more information.

FCC/DOC Warnings

This equipment generates and uses radio frequency energy and, if not installed and used in strict accordance with the instructions in this manual and the CE marking Declaration of Conformity*, may cause interference to radio and television reception. Classification requirements are the same for the Federal Communications Commission (FCC) and the Canadian Department of Communications (DOC).

Changes or modifications not expressly approved by NI could void the user's authority to operate the equipment under the FCC Rules.

Class A

Federal Communications Commission

This equipment has been tested and found to comply with the limits for a Class A digital device, pursuant to part 15 of the FCC Rules. These limits are designed to provide reasonable protection against harmful interference when the equipment is operated in a commercial environment. This equipment generates, uses, and can radiate radio frequency energy and, if not installed and used in accordance with the instruction manual, may cause harmful interference to radio communications. Operation of this equipment in a residential area is likely to cause harmful interference in which case the user is required to correct the interference at their own expense.

Canadian Department of Communications

This Class A digital apparatus meets all requirements of the Canadian Interference-Causing Equipment Regulations.

Cet appareil numérique de la classe A respecte toutes les exigences du Règlement sur le matériel brouilleur du Canada.

Compliance with EU Directives

Users in the European Union (EU) should refer to the Declaration of Conformity (DoC) for information* pertaining to the CE marking. Refer to the Declaration of Conformity (DoC) for this product for any additional regulatory compliance information. To obtain the DoC for this product, visit ni.com/certification, search by model number or product line, and click the appropriate link in the Certification column.

* The CE marking Declaration of Conformity contains important supplementary information and instructions for the user or installer.

Conventions

The following conventions are used in this manual:

<>

Angle brackets that contain numbers separated by an ellipsis represent a range of values associated with a bit or signal name—for example, AO <3..0>.

»

The » symbol leads you through nested menu items and dialog box options to a final action. The sequence **File»Page Setup»Options** directs you to pull down the **File** menu, select the **Page Setup** item, and select **Options** from the last dialog box.



This icon denotes a note, which alerts you to important information.



This icon denotes a caution, which advises you of precautions to take to avoid injury, data loss, or a system crash.



When symbol is marked on a product, it denotes a warning advising you to take precautions to avoid electrical shock.

italic

Italic text denotes variables, emphasis, a cross-reference, or an introduction to a key concept. Italic text also denotes text that is a placeholder for a word or value that you must supply.

monospace

Text in this font denotes text or characters that you should enter from the keyboard, sections of code, programming examples, and syntax examples. This font is also used for the proper names of disk drives, paths, directories, programs, subprograms, subroutines, device names, functions, operations, variables, filenames, and extensions.

Contents

Chapter 1

Introduction

About the NI 1422	1-1
Using PXI with CompactPCI.....	1-2
Software Overview	1-3
NI-IMAQ Driver Software	1-3
National Instruments Application Software	1-4
Vision Builder for Automated Inspection	1-4
Vision Development Module	1-4
Integration with DAQ and Motion Control	1-5

Chapter 2

Hardware Overview

Functional Overview.....	2-1
Differential/TTL Level Converters	2-2
LUTs.....	2-2
Multiple-Tap Data Formatter	2-3
SDRAM.....	2-3
Advanced Clock Generation.....	2-3
RS-232 Serial Interface (UART).....	2-3
Trigger Control and Mapping Circuitry	2-3
High-Speed Timing	2-4
Acquisition, Scaling, ROI.....	2-4
Scatter-Gather DMA Controllers	2-4
Bus Master PCI Interface	2-4
Board Configuration NVRAM.....	2-4
Video Acquisition.....	2-5
Start Conditions	2-5
Acquisition Window Control	2-5

Chapter 3

Signal Connections

I/O Connector	3-1
Signal Descriptions	3-3

Appendix A
Technical Support and Professional Services

Glossary

Index

Introduction

This chapter describes the NI PXI/PCI-1422 (NI 1422) image acquisition device and your software programming choices.

About the NI 1422

The NI 1422 is an image acquisition device for PXI, PCI, and CompactPCI chassis that supports a diverse range of digital cameras from several different camera companies. The NI 1422 acquires digital images in real time and can store the images in onboard frame memory or transfer them directly to system memory. The device can capture up to 16 bits of data at a time at clock speeds up to 40 MHz.

The NI 1422 is simple to configure and is factory calibrated so that you can easily install the device and begin acquiring images. The NI 1422 ships with NI Vision Acquisition Software, which includes NI-IMAQ, the National Instruments driver software you can use to directly control the NI 1422 and other National Instruments image acquisition devices. Using NI-IMAQ, you can quickly and easily start your applications without having to program the device at the register level.

Featuring a high-speed data flow path, the NI 1422 is ideal for both industrial and scientific environments. As a stand-alone device, the NI 1422 supports up to 16 bits of differential video data, four general-purpose control lines that can be configured to generate precise timing signals to control digital camera acquisition, and four external input/output (I/O) lines that you can use as triggers or as high-speed digital I/O lines. If you require more advanced triggering or digital I/O lines (either digital or analog), you can use the NI 1422 and NI-IMAQ with the National Instruments Data Acquisition (DAQ) product line.

A common problem with other image acquisition devices is that you cannot easily synchronize several functions to a common trigger or timing event. The NI 1422 uses its Real-Time System Integration (RTSI) bus to solve this problem. The RTSI bus consists of the National Instruments RTSI bus interface and ribbon cable to route additional timing and trigger signals between the NI 1422 and up to four National Instruments DAQ or image

acquisition devices in your computer. The RTSI bus can even synchronize multiple image acquisition hardware captures.

For detailed specifications of the NI 1422, refer to the *Specifications* section of *Getting Started with the NI PXI/PCI-1422*.

Using PXI with CompactPCI

Using PXI-compatible products with standard CompactPCI products is an important feature provided by the *PXI Specification*, Revision 1.0. If you use a PXI-compatible plug-in device in a standard CompactPCI chassis, you will be unable to use PXI-specific functions, but you can still use the basic plug-in device functions. For example, the RTSI bus on the NI PXI-1422 device is available in a PXI chassis, but not in a CompactPCI chassis.

The CompactPCI specification permits vendors to develop sub-buses that coexist with the basic PCI interface on the CompactPCI bus. Compatible operation is not guaranteed between CompactPCI devices with different sub-buses or between CompactPCI devices with sub-buses and PXI. The standard implementation for CompactPCI does not include these sub-buses. The NI PXI-1422 device works in any standard CompactPCI chassis adhering to the *PICMG 2.0 R2.1 CompactPCI* core specification using the 64-bit definition for J2.

PXI-specific features are implemented on the J2 connector of the CompactPCI bus. Table 1-1 lists the J2 pins the NI PXI-1422 device uses. The PXI device is compatible with any CompactPCI chassis with a sub-bus that does not drive these lines. Even if the sub-bus is capable of driving these lines, the PXI device is still compatible as long as those pins on the sub-bus are disabled by default and are never enabled. Damage may result if these lines are driven by the sub-bus.

Table 1-1. Pins Used by the NI PXI-1422 Device

PXI-1422 Signal	PXI Pin Name	PXI J2 Pin Number
RTSI Trigger <0..6>	PXI Trigger <0..6>	B16, A16, A17, A18, B18, C18, E18

Software Overview

Programming the NI 1422 requires the NI-IMAQ driver software for controlling the hardware. National Instruments also offers the following application software packages for analyzing and processing your acquired images.

- **Vision Builder for Automated Inspection (AI)**—Allows you to configure solutions to common inspection tasks.
- **National Instruments Vision Development Module**—Provides customized control over hardware and algorithms.

The following sections provide an overview of the driver software and the application software. For detailed information about individual software packages, refer to the documentation specific to each package.

NI-IMAQ Driver Software

The NI 1422 ships with NI Vision Acquisition Software, which includes the NI-IMAQ driver software. NI-IMAQ has an extensive library of functions—such as routines for video configuration, continuous and single shot image acquisition, memory buffer allocation, trigger control, and device configuration—you can call from the application development environment (ADE). NI-IMAQ handles many of the complex issues between the computer and the image acquisition device, such as programming interrupts and camera control.

NI-IMAQ performs all functions required for acquiring and saving images but does not perform image analysis. For image analysis functionality, refer to the *National Instruments Application Software* section of this chapter.

NI-IMAQ also provides the interface path between the NI 1422 and LabVIEW, LabWindows™/CVI™, or a text-based programming environment. The NI-IMAQ software kit includes a series of libraries for image acquisition for LabVIEW, LabWindows/CVI, and Measurement Studio, which contains libraries for Microsoft Visual Basic.

NI-IMAQ features both high-level and low-level functions. Examples of high-level functions include the sequences to acquire images in multi-buffer, single-shot, or continuous mode. An example of a low-level function is configuring an image sequence, since it requires advanced understanding of the image acquisition device and image acquisition principles.

National Instruments Application Software

This section describes the National Instruments application software packages you can use to analyze and process the images you acquire with the NI 1422.

Vision Builder for Automated Inspection

NI Vision Builder for Automated Inspection (AI) is configurable machine vision software that you can use to prototype, benchmark, and deploy applications. Vision Builder AI does not require programming, but is scalable to powerful programming environments.

Vision Builder AI allows you to easily configure and benchmark a sequence of visual inspection steps, as well as deploy the visual inspection system for automated inspection. With Vision Builder AI, you can perform powerful visual inspection tasks and make decisions based on the results of individual tasks. You also can migrate the configured inspection to LabVIEW, extending the capabilities of the applications if necessary.

Vision Development Module

The Vision Development Module is an image acquisition, processing, and analysis library of more than 270 functions for the following common machine vision tasks:

- Pattern matching
- Particle analysis
- Gauging
- Taking measurements
- Grayscale, color, and binary image display

You can use the Vision Development Module functions individually or in combination. With the Vision Development Module, you can acquire, display, and store images, as well as perform image analysis, and processing. Using the Vision Development Module, imaging novices and experts can program the most basic or complicated image applications without knowledge of particular algorithm implementations.

As a part of the Vision Development Module, NI Vision Assistant is an interactive prototyping tool for machine vision and scientific imaging developers. With Vision Assistant, you can prototype vision applications quickly and test how various vision image processing functions work.

Vision Assistant generates a Builder file, which is a text description containing a recipe of the machine vision and image processing functions. This Builder file provides a guide you can use for developing applications in any ADE, such as LabWindows/CVI or Visual Basic, using the Vision Assistant machine vision and image processing libraries. Using the LabVIEW VI creation wizard, Vision Assistant can create LabVIEW VI block diagrams that perform the prototype you created in Vision Assistant. You then can use LabVIEW to add functionality to the generated VI.

Integration with DAQ and Motion Control

Platforms that support NI-IMAQ also support NI-DAQ and a variety of National Instruments DAQ devices. This allows integration between image acquisition devices and National Instruments DAQ products.

Use National Instruments high-performance stepper and servo motion control products with pattern matching software in inspection and guidance applications, such as locating alignment markers on semiconductor wafers, guiding robotic arms, inspecting the quality of manufactured parts, and locating cells.

Hardware Overview

This chapter presents an overview of the hardware functions on the NI 1422 and explains the operation of each functional unit making up the NI 1422.

Functional Overview

The NI 1422 features a flexible, high-speed data path optimized for the reception and formatting of video data from digital cameras.

The block diagram in Figure 2-1 illustrates the key functional components of the NI 1422.

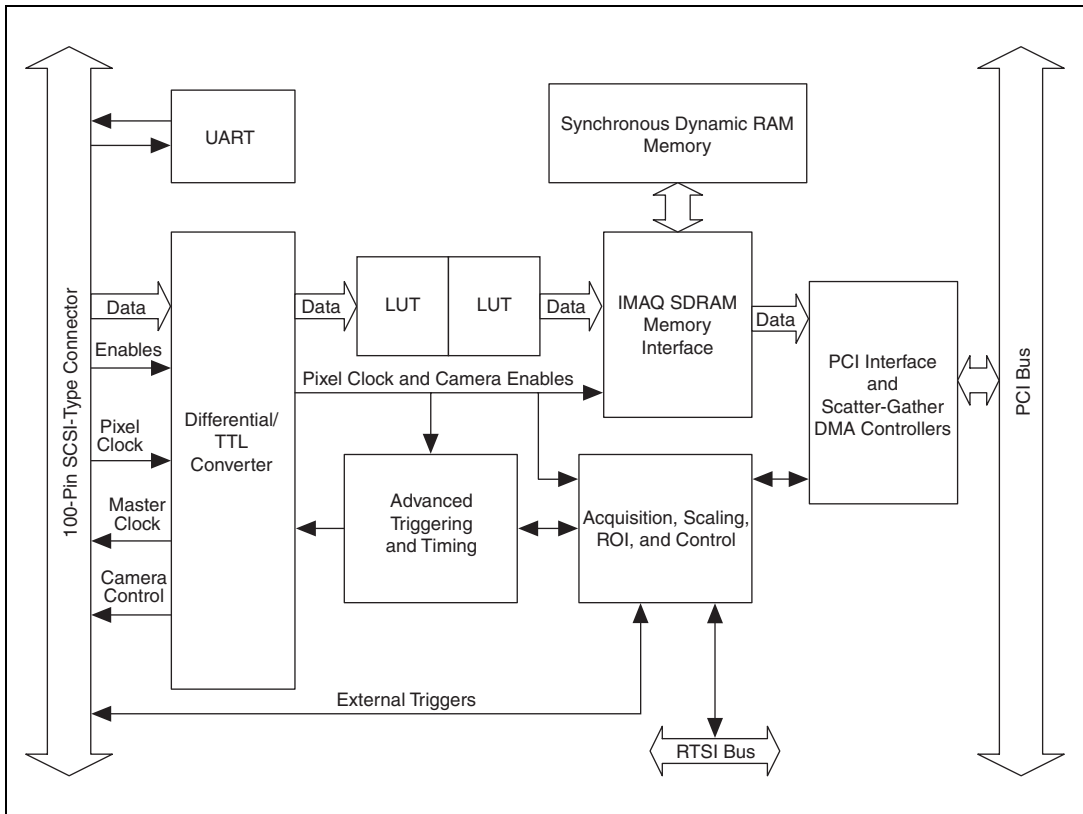

Figure 2-1. NI 1422 Block Diagram

Differential/TTL Level Converters

The NI 1422 can drive and receive either TTL or differential-level camera control signals. These signal levels can be controlled independently for the control and enable lines on the 100-pin SCSI-type connector.

LUTs

The NI 1422 uses a 64 KB-by-16 bit lookup table (LUT) that you can use for two 256 B-by-8 bit LUT operations or one 64 KB-by-16 bit lookup table. You can configure this LUT to perform simple imaging operations such as contrast enhancement, data inversion, gamma manipulation, or other nonlinear transfer functions.

Multiple-Tap Data Formatter

Many digital cameras transfer multiple channels, or taps, of data simultaneously to increase the frame rate of the camera. However, the data in each tap may not be transferred in the traditional top-left to bottom-right direction. Also, the taps may not transfer data in similar directions.

The multiple-tap data formatting circuitry on the NI 1422 can reorder the data from up to two 8-bit taps. The data from each tap can be independently scanned either from left-to-right or right-to-left and top-to-bottom or bottom-to-top.

SDRAM

The NI 1422 comes with 32 MB of onboard high-speed synchronous dynamic RAM (SDRAM).

Advanced Clock Generation

The advanced clock generation circuitry on the NI 1422 generates frequencies from 500 kHz to 40 MHz for digital cameras that require an external clock.

RS-232 Serial Interface (UART)

You can use the RS-232 serial interface on the 100-pin SCSI-type connector to control digital cameras that also have a serial interface for camera control and configuration.



Note The RS-232 serial interface is accessible only via the NI-IMAQ driver software.

Trigger Control and Mapping Circuitry

The trigger control and mapping circuitry routes, monitors, and drives the external and RTSI bus trigger lines. You can configure each of these lines to start an acquisition on a rising or falling edge. In addition, you can drive each line asserted or unasserted, similar to a digital I/O line. You can also map pulses from the high-speed timing circuitry or many of the NI 1422 status signals to these trigger lines. There are four external and four RTSI bus triggers. You can program each of these triggers in polarity and direction.

High-Speed Timing

The high-speed timing circuitry on the NI 1422, built from high-speed counters, allows you to specify or generate precise, real-time control signals. You can map the output of this circuitry to a trigger line to provide accurate pulses and pulse trains.

Acquisition, Scaling, ROI

The acquisition, scaling, and region-of-interest (ROI) circuitry monitors the incoming video signals and routes the active pixels to the multiple-tap data formatter and SDRAM memory. The NI 1422 can perform ROI and scaling on all video lines and frames. Pixel and line scaling transfers certain multiples (two, four, or eight) of pixels and lines to onboard memory. In an ROI acquisition, you select an area within the acquisition window to transfer to the PCI bus.

Scatter-Gather DMA Controllers

The NI 1422 uses three independent onboard direct memory access (DMA) controllers. The DMA controllers transfer data between the onboard SDRAM memory buffers and the PCI bus. Each of these controllers supports scatter-gather DMA, which allows the DMA controller to reconfigure on-the-fly. Thus, the NI 1422 can perform continuous image transfers directly to either contiguous or fragmented memory buffers.

Bus Master PCI Interface

The NI 1422 implements the PCI interface with a National Instruments custom application-specific integrated circuit (ASIC), the PCI MITE. The PCI interface can transfer data at a maximum rate of 132 Mbytes/s in bus master mode. The NI 1422 can generate 8-, 16-, and 32-bit memory read and write cycles, both single and multiple. In slave mode, the NI 1422 is a medium-speed decoder that accepts both memory and configuration cycles. The interface logic ensures that the NI 1422 can meet PCI loading, driving, and timing requirements.

Board Configuration NVRAM

The NI 1422 contains onboard nonvolatile RAM (NVRAM) that configures all registers on power-up.

Video Acquisition

The NI 1422 can acquire digital video in a variety of modes and store the images in the onboard SDRAM memory or transfer the images directly to PCI system memory.

Start Conditions

The NI 1422 can start acquisitions in a variety of conditions:

- **Software control**—The NI 1422 supports software control of acquisition start. You can configure the NI 1422 to capture a fixed number of fields or frames. This configuration is useful for capturing a single frame or a sequence of frames.
- **Trigger control**—You can start an acquisition by enabling external or RTSI bus trigger lines. Each of these 11 inputs can start a video acquisition on a rising or falling edge. You can use all four external triggers and up to four RTSI bus triggers simultaneously.
- **Delayed acquisition**—You can use either software or triggers to start acquisitions instantaneously or after skipping a specific number of images.
- **Frame/field selection**—With an interlaced camera and the NI 1422 in frame mode, you can program the NI 1422 to start an acquisition on any odd or even field.

Acquisition Window Control

You can configure numerous parameters on the NI 1422 to control the video acquisition window. A brief description of each parameter follows:

- **Acquisition window**—The NI 1422 allows the user to specify a particular region of active pixels and active lines within the incoming video data. The active pixel region selects the starting pixel and number of pixels to be acquired relative to the assertion edge of the horizontal (or line) enable signal from the camera. The active line region selects the starting line and number of lines to be acquired relative to the assertion edge of the vertical (or frame) enable signal.
- **Region of interest**—The NI 1422 uses a second level of active pixel and active line regions for selecting a region of interest. Using the region-of-interest circuitry, the board acquires only a selected subset of the acquisition window.

- **Scaling down**—The scaling-down circuitry also controls the active acquisition region. The NI 1422 can scale down a frame by reducing the number of pixels per line, the number of lines per frame, or both. For active pixel selection, the NI 1422 can select every pixel, every other pixel, every fourth pixel, or every eighth pixel. For active line selection, the NI 1422 can select every line, every other line, every fourth line, or every eighth line. You can use the scaling-down circuitry in conjunction with the region-of-interest circuitry.
- **Interlaced video**—The NI 1422 supports both interlaced and noninterlaced digital video signals. In interlaced mode, the NI 1422 combines the odd and even fields into one contiguous frame for analysis. In noninterlaced mode, each field is treated as an independent frame.

Signal Connections

This chapter describes signal connections for the NI 1422.

I/O Connector

The NI 1422 100-pin SCSI-type connector connects to all digital video data inputs, digital enable inputs, camera control outputs, RS-232 serial interface, and the external trigger signals. To access these connections, you can build your own custom cable or use one of the optional cables from National Instruments.



Note Refer to the National Instruments Web site, ni.com/vision, for the latest information on optional cables and the cameras they support.

Figure 3-1 shows the pinout of the 100-pin SCSI-type connector.

Data0+	1	51	Not Used
Data0-	2	52	Not Used
Data1+	3	53	Not Used
Data1-	4	54	Not Used
Data2+	5	55	Not Used
Data2-	6	56	Not Used
Data3+	7	57	Not Used
Data3-	8	58	Not Used
Data4+	9	59	Not Used
Data4-	10	60	Not Used
Data5+	11	61	Not Used
Data5-	12	62	Not Used
Data6+	13	63	Not Used
Data6-	14	64	Not Used
Data7+	15	65	Not Used
Data7-	16	66	Not Used
Data8+	17	67	Not Used
Data8-	18	68	Not Used
Data9+	19	69	Not Used
Data9-	20	70	Not Used
Data10+	21	71	Not Used
Data10-	22	72	Not Used
Data11+	23	73	Not Used
Data11-	24	74	Not Used
Data12+	25	75	Not Used
Data12-	26	76	Not Used
Data13+	27	77	Not Used
Data13-	28	78	Not Used
Data14+	29	79	Not Used
Data14-	30	80	Not Used
Data15+	31	81	Not Used
Data15-	32	82	Not Used
Control0+	33	83	RI (RS-232)
Control0-	34	84	DTR (RS-232)
Control1+	35	85	DSR (RS-232)
Control1-	36	86	RTS (RS-232)
Control2+	37	87	CTS (RS-232)
Control2-	38	88	DCD (RS-232)
Control3+	39	89	Master Clock1+
Control3-	40	90	Master Clock1-
EnableA+	41	91	Master Clock0+
EnableA-	42	92	Master Clock0-
EnableB+	43	93	SOUT (RS-232)
EnableB-	44	94	SIN (RS-232)
EnableC+	45	95	External Trigger0
EnableC-	46	96	External Trigger1
EnableD+	47	97	External Trigger2
EnableD-	48	98	External Trigger3
Pixel Clock +	49	99	GND
Pixel Clock -	50	100	GND

Figure 3-1. NI 1422 Pin Assignments

Signal Descriptions

Table 3-1 describes each signal connection on the 100-pin SCSI-type connector.

Table 3-1. I/O Connector Signals

Signal Name	Description
Control<0..3> \pm	You can use the control lines on the NI 1422 to control digital camera features and timing information. Either static or dynamic, TTL or differential, signals can be generated on these lines to perform such functions as generating integration or shutter pulses to the digital cameras.
CTS	Clear to Send is used for RS-232 connections.
Data<0..15> \pm	Data<0..15> \pm allows you to connect data up to 16 bits wide in differential format to the NI 1422.
DCD	Data Carrier Detect is used for RS-232 connections.
DSR	Data Set Ready is used for RS-232 connections.
DTR	Data Terminal Ready is used for RS-232 connections.
Enable<A..D> \pm	The NI 1422 can receive any combination of up to four enable signals. These signals can be either TTL or differential. Examples of camera signals which might be connected to these pins are frame enable, line enable, even enable and odd enable. If your camera has a separate field signal, that line should be connected to Enable C.
External Trigger<0..3>	External Trigger<0..3> are TTL I/O lines used to start an acquisition or output to control external events. You can program the triggers to be rising-edge or falling-edge sensitive. You can also program the triggers to be programmatically asserted or unasserted similar to the function of a digital I/O line or to contain internal status signals (by using the onboard events) or specific pulse widths.
GND	GND is a direct connection to digital ground on the NI 1422.
Master Clock<0..1> \pm	You can use these two sets of pins to generate a master clock signal for your digital camera. Possible clock frequencies range from 500 kHz to 40 MHz.
Pixel Clock \pm	The NI 1422 uses the Pixel Clock input as a reference clock to latch the incoming video data.
RI	Ring Indicator is used for RS-232 connections.

Table 3-1. I/O Connector Signals (Continued)

Signal Name	Description
RTS	Request to Send is used for RS-232 connections.
SIN	Serial Data In is used for RS-232 connections.
SOUT	Serial Data Out is used for RS-232 connections.



Technical Support and Professional Services

Visit the following sections of the National Instruments Web site at ni.com for technical support and professional services:

- **Support**—Online technical support resources at ni.com/support include the following:
 - **Self-Help Resources**—For answers and solutions, visit the award-winning National Instruments Web site for software drivers and updates, a searchable KnowledgeBase, product manuals, step-by-step troubleshooting wizards, thousands of example programs, tutorials, application notes, instrument drivers, and so on.
 - **Free Technical Support**—All registered users receive free Basic Service, which includes access to hundreds of Application Engineers worldwide in the NI Discussion Forums at ni.com/forums. National Instruments Application Engineers make sure every question receives an answer.

For information about other technical support options in your area, visit ni.com/services or contact your local office at ni.com/contact.

- **Training and Certification**—Visit ni.com/training for self-paced training, eLearning virtual classrooms, interactive CDs, and Certification program information. You also can register for instructor-led, hands-on courses at locations around the world.
- **System Integration**—If you have time constraints, limited in-house technical resources, or other project challenges, National Instruments Alliance Partner members can help. To learn more, call your local NI office or visit ni.com/alliance.
- **Declaration of Conformity (DoC)**—A DoC is our claim of compliance with the Council of the European Communities using the manufacturer's declaration of conformity. This system affords the user protection for electronic compatibility (EMC) and product safety. You can obtain the DoC for your product by visiting ni.com/certification.

- **Calibration Certificate**—If your product supports calibration, you can obtain the calibration certificate for your product at ni.com/calibration.

If you searched ni.com and could not find the answers you need, contact your local office or NI corporate headquarters. Phone numbers for our worldwide offices are listed at the front of this manual. You also can visit the Worldwide Offices section of ni.com/niglobal to access the branch office Web sites, which provide up-to-date contact information, support phone numbers, email addresses, and current events.

Glossary

Symbol	Prefix	Value
p	pico	10^{-12}
n	nano	10^{-9}
μ	micro	10^{-6}
m	milli	10^{-3}
k	kilo	10^3
M	mega	10^6
G	giga	10^9
T	tera	10^{12}

Symbols

%	Percent.
+	Positive of, or plus.
/	Per.
Ω	Ohm.
\pm	Plus or minus.
-	Negative of, or minus.

A

A	Amperes.
AC	Alternating current.
acquisition window	The image size specific to a video standard or camera resolution.

active line region	The region of lines actively being stored. Defined by a line start (relative to the vertical synchronization signal) and a line count.
active pixel region	The region of pixels actively being stored. Defined by a pixel start (relative to the horizontal synchronization signal) and a pixel count.
address	Value that identifies a specific location (or series of locations) in memory.
ANSI	American National Standards Institute.
API	Application programming interface.
area	A rectangular portion of an acquisition window or frame that is controlled and defined by software.
array	Ordered, indexed set of data elements of the same type.
ASIC	Application-Specific Integrated Circuit. A proprietary semiconductor component designed and manufactured to perform a set of specific functions for specific customer needs.

B

b	Bit. One binary digit, either 0 or 1.
B	Byte. Eight related bits of data, an eight-bit binary number; also used to denote the amount of memory required to store one byte of data
buffer	Temporary storage for acquired data.
bus	A group of conductors that interconnect individual circuitry in a computer, such as the PCI bus; typically the expansion vehicle to which I/O or other devices are connected.

C

C	Celsius.
cache	High-speed processor memory that buffers commonly used instructions or data to increase processing throughput.
CMOS	Complementary metal-oxide semiconductor.

Compact PCI	Refers to the core specification defined by the PCI Industrial Computer Manufacturer's Group (PICMG).
conversion device	Device that transforms a signal from one form to another. For example, analog-to-digital converters (ADCs) for analog input and digital-to-analog converters (DACs) for analog output.
CPU	Central processing unit.
D	
DAQ	Data acquisition. (1) Collecting and measuring electrical signals from sensors, transducers, and test probes or fixtures and inputting them to a computer for processing. (2) Collecting and measuring the same kinds of electrical signals with A/D or DIO boards plugged into a computer, and possibly generating control signals with D/A and/or DIO boards in the same computer.
dB	Decibel. The unit for expressing a logarithmic measure of the ratio of two signal levels: $\text{dB} = 20\log_{10} V1/V2$, for signals in volts.
DC	Direct current.
default setting	A default parameter value recorded in the driver; in many cases, the default input of a control is a certain value (often 0) that means <i>use the current default setting</i> .
DIN	Deutsche Industrie Norme. A format for electrical connectors.
DMA	Direct memory access. A method by which data can be transferred to and from computer memory from and to a device or memory on the bus while the processor does something else; DMA is the fastest method of transferring data to/from computer memory.
DRAM	Dynamic RAM.
drivers	Software that controls a specific hardware device, such as an image acquisition board.
dynamic range	The ratio of the largest signal level a circuit can handle to the smallest signal level it can handle (usually taken to be the noise level), normally expressed in decibels.

E

EEPROM	Electrically erasable programmable read-only memory. ROM that can be erased with an electrical signal and reprogrammed.
external trigger	A voltage pulse from an external source that triggers an event such as A/D conversion.

F

field	For an interlaced video signal, a field is half the number of horizontal lines needed to represent a frame of video. The first field of a frame contains all the odd-numbered lines, the second field contains all of the even-numbered lines.
FIFO	First-in first-out memory buffer. The first data stored is the first data sent to the acceptor; FIFOs are used on image acquisition devices to temporarily store incoming data until that data can be retrieved.
frame	A complete image. In interlaced formats, a frame is composed of two fields.
ft	Feet.

H

h	Hour.
hue	Represents the dominant color of a pixel. The hue function is a continuous function that covers all the possible colors generated using the R, G, and B primaries. <i>See also</i> RGB .
Hz	Hertz. Frequency in units of 1/second.

I

I/O	Input/output. The transfer of data to/from a computer system involving communications channels, operator interface devices, and/or data acquisition and control interfaces.
IC	Integrated circuit.

IEEE	Institute of Electrical and Electronics Engineers.
in.	Inches.
instrument driver	A set of high-level software functions, such as NI-IMAQ, that control specific plug-in computer boards. Instrument drivers are available in several forms, ranging from a function callable from a programming language to a virtual instrument (VI) in LabVIEW.
interlaced	A video frame composed of two interleaved fields. The number of lines in a field are half the number of lines in an interlaced frame.
interrupt	A computer signal indicating that the CPU should suspend its current task to service a designated activity.
interrupt level	The relative priority at which a device can interrupt.
IRQ	Interrupt request. <i>See also</i> interrupt.
K	
k	Kilo. The standard metric prefix for 1,000, or 10^3 , used with units of measure such as volts, hertz, and meters.
K	Kilo. The prefix for 1,024, or 2^{10} , used with B in quantifying data or computer memory.
kbytes/s	A unit for data transfer that means 1,000 or 10^3 bytes/s.
Kword	1,024 words of memory.
L	
line count	The total number of horizontal lines in the picture.
LSB	Least significant bit.
LUT	Lookup table. Table containing values used to transform the gray-level values of an image. For each gray-level value in the image, the corresponding new value is obtained from the lookup table.

M

m	Meters.
M	(1) Mega, the standard metric prefix for 1 million or 10^6 , when used with units of measure such as volts and hertz; (2) mega, the prefix for 1,048,576, or 2^{20} , when used with B to quantify data or computer memory.
MB	Megabyte of memory.
Mbytes/s	A unit for data transfer that means 1 million or 10^6 bytes/s.
memory buffer	See buffer .
memory window	Continuous blocks of memory that can be accessed quickly by changing addresses on the local processor.
MSB	Most significant bit.
MTBF	Mean time between failure.
mux	Multiplexer. A switching device with multiple inputs that selectively connects one of its inputs to its output.

N

NI-IMAQ	Driver software for National Instruments image acquisition hardware.
noninterlaced	A video frame where all the lines are scanned sequentially, instead of divided into two frames as in an interlaced video frame.
NTSC	National Television Standards Committee. The committee that developed the color video standard used primarily in North America, which uses 525 lines per frame. See also PAL .
NVRAM	Nonvolatile RAM. RAM that is not erased when a device loses power or is turned off.

O

operating system	Base-level software that controls a computer, runs programs, interacts with users, and communicates with installed hardware or peripheral devices.
------------------	----------------------------------------------------------------------------------------------------------------------------------------------------

P

PAL	Phase Alternation Line. One of the European video color standards; uses 625 lines per frame. <i>See also</i> NTSC .
PCI	Peripheral Component Interconnect. A high-performance expansion bus architecture originally developed by Intel to replace ISA and EISA. PCI offers a theoretical maximum transfer rate of 132 Mbytes/s.
PFI	Programmable function input.
PGIA	Programmable gain instrumentation amplifier.
pixel	Picture element. The smallest division that makes up the video scan line; for display on a computer monitor, a pixel's optimum dimension is square (aspect ratio of 1:1, or the width equal to the height).
pixel clock	Divides the incoming horizontal video line into pixels.
pixel count	The total number of pixels between two horizontal synchronization signals. The pixel count determines the frequency of the pixel clock.
protocol	The exact sequence of bits, characters, and control codes used to transfer data between computers and peripherals through a communications channel.
pts	Points.
PXI	PCI eXtensions for Instrumentation. An open specification that builds on the CompactPCI specification by adding instrumentation-specific features.

R

RAM	Random-access memory.
real time	A property of an event or system in which data is processed as it is acquired instead of being accumulated and processed at a later time.
resolution	The smallest signal increment that can be detected by a measurement system. Resolution can be expressed in bits, in proportions, or in percent of full scale. For example, a system has 12-bit resolution, one part in 4,096 resolution, and 0.0244 percent of full scale.

RGB	Color encoding scheme using red, green, and blue (RGB) color information where each pixel in the color image is encoded using 32 bits: 8 bits for red, 8 bits for green, 8 bits for blue, and 8 bits for the alpha value (unused).
ribbon cable	A flat cable in which the conductors are side by side.
ROI	Region of interest. A hardware-programmable rectangular portion of the acquisition window.
ROM	Read-only memory.
RTSI bus	Real-Time System Integration Bus. The National Instruments timing bus that connects image acquisition and DAQ boards directly, by means of connectors on top of the boards, for precise synchronization of functions.

S

s	Seconds.
scaling down circuitry	Circuitry that scales down the resolution of a video signal.
scatter-gather DMA	A type of DMA that allows the DMA controller to reconfigure on-the-fly.
SDRAM	Synchronous dynamic RAM.
SO-DIMM	Small outline dual inline memory module.
SRAM	Static RAM.
system RAM	RAM installed on a personal computer and used by the operating system, as contrasted with onboard RAM.

T

tap	A stream of pixels from a camera. Some cameras send multiple streams, or taps, of data over a cable simultaneously to increase transfer rate.
transfer rate	The rate, measured in bytes/s, at which data is moved from source to destination after software initialization and set up operations. The maximum rate at which the hardware can operate.
trigger	Any event that causes or starts some form of data capture.

trigger control and mapping circuitry Circuitry that routes, monitors, and drives external and RTSI bus trigger lines. You can configure each of these lines to start or stop acquisition on a rising or falling edge.

TTL Transistor-transistor logic.

V

VI Virtual Instrument. (1) A combination of hardware and/or software elements, typically used with a PC, that has the functionality of a classic stand-alone instrument (2) A LabVIEW software module (VI), which consists of a front panel user interface and a block diagram program.

Index

A

acquisition
 acquisition window control, 2-5
 start conditions, 2-5
 video acquisition, 2-5
acquisition, scaling, and ROI circuitry, 2-4
advanced clock generation, 2-3
application software
 Vision Builder AI, 1-4
 Vision Development Module, 1-4

B

block diagram of NI 1422, 2-2
board configuration NVRAM, 2-4
bus master PCI interface, 2-4

C

calibration certificate (NI resources), A-2
compactPCI, using with PXI, 1-2
conventions used in the manual, *v*

D

Declaration of Conformity (NI resources), A-1
diagnostic tools (NI resources), A-1
differential/TTL converters, 2-2
documentation
 conventions used in the manual, *v*
 NI resources, A-1
drivers (NI resources), A-1

E

examples (NI resources), A-1

H

help, technical support, A-1
high-speed timing, 2-4

I

I/O connector, 3-1
instrument drivers (NI resources), A-1
integration with DAQ and motion control, 1-5

K

KnowledgeBase, A-1

L

LabVIEW
 migrating inspection from Vision
 Builder AI, 1-4
lookup tables (LUTs), 2-2
LUTS (lookup tables), 2-2

M

motion control, integrating with, 1-5
multiple-tap data formatter, 2-3

N

National Instruments support
 and services, A-1
NI 1422
 block diagram, 2-2
 functional overview, 2-1
 hardware overview, 1-3
 I/O connector signals, 3-3
 overview, 1-1
 SCSI pin assignments, 3-2

- software programming choices, 1-3
- NI support and services, A-1
- NI-IMAQ driver software, 1-3

P

- programming examples (NI resources), A-1
- PXI, using with compactPCI, 1-2

R

- RS-232 serial interface, 2-3

S

- scatter-gather DMA controllers, 2-4
- SCSI pin assignments, 3-2
- SDRAM, 2-3
- signal connections
 - I/O connector, 3-1
- software (NI resources), A-1
- software programming choices
 - NI Vision, 1-4
 - NI-IMAQ driver software, 1-3
 - Vision Builder AI, 1-4

T

- technical support, A-1
- training and certification (NI resources), A-1
- troubleshooting (NI resources), A-1

V

- video acquisition, 2-5
- Vision Builder AI
 - migrating to LabVIEW, 1-4

W

- Web resources, A-1