

# SCB-100

## 100-Pin Female SCSI to 100-Pin Female Screw Terminal, Desktop Mount Terminal Block

This document describes how to connect and use the SCB-100 with 100-pin data acquisition (DAQ) devices and lists specifications. The SCB-100 is a shielded I/O connector block with 100 screw terminals for easy signal connection to the following NI devices and modules:

- Digital I/O (DIO)—NI 6508, NI 6509, NI 6511, NI 6512, NI 6513, NI 6514, NI 6515, NI 6527, NI 6528, NI 6529, PCI-DIO-96
- Counter/Timer—NI 6624
- Multifunction I/O (MIO)—NI 6025E, NI 6031E, NI 6033E, NI 6071E
- Other devices with a 100-pin 0.050 series shielded D-type I/O connector



**Note** To use the SCB-100 with a digital I/O or counter/timer device, you must change the default switch setting. Refer to [Using the SCB-100 with Digital I/O and Counter/Timer Devices](#) for more information.

**Figure 1.** SCB-100 Parts Locator Diagram

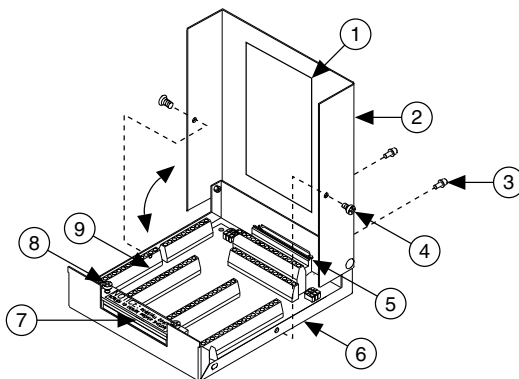

- |                                     |                           |
|-------------------------------------|---------------------------|
| 1. Quick Reference Label (Optional) | 6. Enclosure Base         |
| 2. Top Cover                        | 7. Strain-Relief Bar      |
| 3. Connector Screw                  | 8. Strain-Relief Screw    |
| 4. Grounding Screw                  | 9. SCB-100 Board Assembly |
| 5. 100-Pin I/O Connector            |                           |



# Contents

---

Icons.....	2
Safety Guidelines.....	2
Electromagnetic Compatibility Guidelines.....	3
What You Need to Get Started.....	4
Getting Started with the SCB-100.....	5
Using the SCB-100 with Digital I/O and Counter/Timer Devices.....	6
Using the SCB-100 with Multifunction I/O Devices.....	7
Connecting Nonreferenced or Floating Signal Sources to Analog Inputs.....	9
Connecting Ground-Referenced Signal Sources to Analog Inputs.....	10
Using the SCB-100 for Thermocouple Measurements .....	10
Removing the Board .....	12
Soldering, Desoldering, and Cutting Via Traces on the SCB-100 Board .....	12
Specifications.....	12
Where to Go Next.....	15
Worldwide Support and Services.....	15

## Icons



---

-  **Notice**—Take precautions to avoid data loss, loss of signal integrity, degradation of performance, or damage to the model.
-  **Caution**—Take precautions to avoid injury. Consult the model documentation for cautionary statements when you see this icon printed on the model. Cautionary statements are localized into French for compliance with Canadian requirements.
-  **Shock Warning**—Take precautions to avoid electrical shock.

## Safety Guidelines

---

The following cautions contain important safety information concerning hazardous voltages and connector blocks.

-  **Caution** The protection provided by the model can be impaired if it is used in a manner not described in the user documentation.
-  **Attention** La protection apportée par le modèle risque d'être endommagée s'il est utilisé d'une autre façon que celle décrite dans la documentation utilisateur.
-  **Caution** Do not connect hazardous voltages (>30 V RMS/42 V peak/60 V DC). Refer to your product documentation for information about the electrical limits of your device or module.



**Attention** Ne pas connecter à des tensions dangereuses ( $> 30 V_{eff}/42 V_{pic}/60 VCC$ ). Reportez-vous à la documentation de votre produit pour plus d'informations sur les limites électriques de votre appareil ou module.



**Caution** Install cover prior to use. To avoid electrical shock, do not remove SCB-100 covers unless you are qualified to do so. Before removing the cover, disconnect any live circuit from the connector block. Replace cover for use.



**Attention** Installez le capot de protection avant l'utilisation. Pour éviter tout choc électrique, ne retirez pas le capot de protection du SCB-100, sauf si vous êtes qualifié pour le faire. Avant de retirer le capot de protection, déconnectez tout circuit sous tension du bloc de connexion. Remettez en place le capot de protection avant l'utilisation.



**Notice** The grounding screws on your SCB-100 are for grounding high-impedance sources, such as a floating source (1 mA maximum) and for terminating the shields of connected cables. Do not use the grounding screws as safety earth ground.

## Electromagnetic Compatibility Guidelines

---

This product was tested and complies with the regulatory requirements and limits for electromagnetic compatibility (EMC) as stated in the product specifications. These requirements and limits are designed to provide reasonable protection against harmful interference when the product is operated in its intended operational electromagnetic environment.

This product is intended for use in residential, commercial, and industrial locations. However, harmful interference may occur in some installations or when the product is connected to a peripheral device or a test object. To minimize interference with radio and television reception and prevent unacceptable performance degradation, install and use this product in strict accordance with the instructions in the product documentation.

Furthermore, any changes or modifications to the product not expressly approved by National Instruments could void your authority to operate it under your local regulatory rules.



**Notice** To ensure the specified EMC performance, operate this product only with shielded cables and accessories.



**Notice** To ensure the specified EMC performance, signal wires routed outside of the enclosure must be contained within a shielded cable and connected to shielded accessories. Cable shields must be terminated to the chassis ground lug using as short a connection as is practical.

# What You Need to Get Started

---

- SCB-100
- (Optional) Quick reference label PDF



**Note** You can find quick reference labels, which specify accessory pinout information for many compatible devices, by going to [ni.com/r/scb100labels](https://ni.com/r/scb100labels).

- 100-pin DAQ device and device documentation
- Cable for your device:
  - SH100M-100M Flex cable (formerly known as SH100-100-F), part number 185095-0x, for digital I/O and counter/timer devices
  - SH100M-100M cable (formerly known as SH100100), part number 182853-0x, for multifunction I/O devices
- Phillips #1 and #2 screwdrivers
- 14 AWG to 26 AWG wire
- Wire cutters
- Wire insulation strippers
- 1/8 in. flathead screwdriver

# Getting Started with the SCB-100

**Figure 2. SCB-100 Board Parts Locator Diagram**

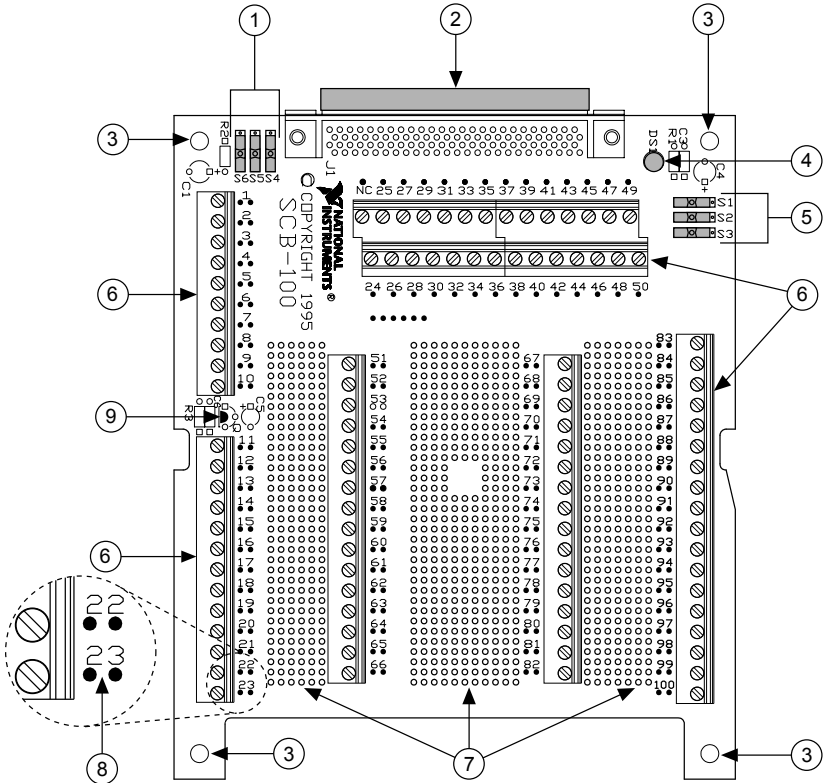

- |                                     |  |
|-------------------------------------|--|
| 1. Switches S4, S5, and S6          | 6. Screw Terminals                               |
| 2. 100-Pin I/O Connector            | 7. Breadboard Area                               |
| 3. Board Mount Screw Hole           | 8. Vias Shorted to Screw Terminal                |
| 4. Signal Accessory Power LED (DS1) | 9. Cold-Junction Compensation Temperature Sensor |
| 5. Switches S1, S2, and S3          |  |

Complete the following steps while referring to the previous figures. If you have not already installed your DAQ device or module, refer to the getting started guide that came with your device for instructions. Remove all cables from the SCB-100 before getting started.

1. Remove the grounding screws on either side of the top cover with a Phillips #1 screwdriver. Open the top cover.
2. (Optional) Attach the quick reference label to the inside of the cover. To find quick reference labels for most compatible devices, go to [ni.com/r/scb100labels](http://ni.com/r/scb100labels).

3. Configure switches for the signal types you are using, as explained in *Using the SCB-100 with Digital I/O and Counter/Timer Devices* or *Using the SCB-100 with Multifunction I/O Devices*.
4. Loosen the strain-relief bar by removing the strain-relief screws with a #2 Phillips screwdriver.
5. Connect the wires to the screw terminals by stripping off ¼ in. of the wire insulation, inserting the wires into the screw terminals, and securely tightening the screws with the flathead screwdriver to a torque of 0.5 N·m to 0.6 N·m (4 in.·lb to 5 in.·lb).
6. Reinstall the strain-relief (if removed) and tighten the strain-relief screws. If the shielded cable is too large to route through the strain-relief hardware, either use multiple, smaller-diameter cables or remove the top strain-relief bar and add insulation or padding if necessary to constrain the cable.
7. Reinsert the grounding screws to ensure proper shielding.
8. Replace the cover.
9. Connect the SCB-100 to the device using the cable.
10. Launch Measurement & Automation Explorer (MAX). In the left panel, expand **Devices and Interfaces** to confirm that your DAQ device or module is recognized, and then configure your device settings.
11. (Optional) Configure the DAQ device or module connected to the SCB-100 by completing the following steps.
  - a. In MAX, right-click your DAQ device or module and select **Configure**.
  - b. Configure the device or module properties and click **OK**.
12. Test specific device functionality. Run a Test Panel in MAX by right-clicking your DAQ device or module and selecting **Test Panels**. Click **Start** to test the device or module functions.





**Note** When you have finished using the SCB-100, power off any external signals connected to the SCB-100 before you power off your computer.

## Using the SCB-100 with Digital I/O and Counter/Timer Devices

---

Digital I/O (NI 65xx) devices, counter/timer (NI 66xx) devices, and DAQ devices without analog input functionality must use the direct feedthrough mode. Move the switches to the direct feedthrough mode switch setting as shown in the following table.

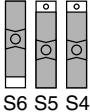
**Table 1.** Digital I/O and Counter/Timer Devices Switch Setting

Switch Setting	Description
 <p>S6 S5 S4</p>  <p>S1 S2 S3</p>	<p><b>Direct feedthrough mode</b>—Move switches S1, S2, S3, S4, S5, and S6 to the positions shown on the left. In this mode:</p> <ul style="list-style-type: none"> <li>All 100 signals from the DAQ device connect directly to screw terminals</li> <li>The signal accessory power LED (DS1) does not light in this configuration.</li> </ul> <p>Refer to the following figure for a detailed diagram.</p>

**Figure 3.** Direct Feedthrough Mode Switch Setting

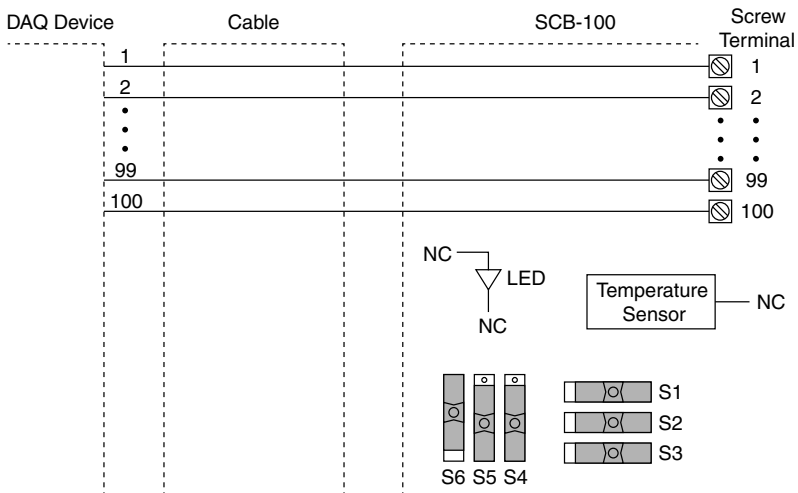

Refer to your device documentation for device signal information.

## Using the SCB-100 with Multifunction I/O Devices

You can take measurements with the SCB-100 and multifunction I/O (NI 60xxE) devices in a number of ways. The SCB-100 has a temperature sensor for cold-junction compensation to accommodate thermocouples. Switches S4, S5, and S6 configure the temperature sensor for different analog input settings. The following table shows the different switch settings for multifunction I/O devices.

**Table 2.** Multifunction I/O Device Switch Settings

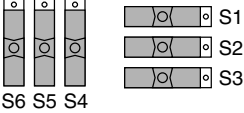
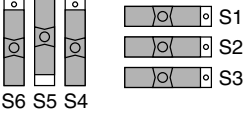
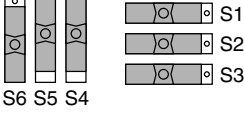
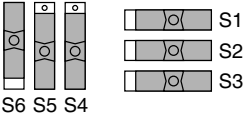
Switch Setting	Description
 <p>S6 S5 S4</p> <p>S1 S2 S3</p>	<p><b>MIO with disabled temperature sensor mode (default configuration)</b>—Move switches S1, S2, S3, S4, S5, and S6 to the positions shown on the left. In this mode:</p> <ul style="list-style-type: none"> <li>• The temperature sensor is not used.</li> <li>• AI 0 and AI 8 are available on screw terminals.</li> <li>• The signal accessory power LED (DS1) lights when the device is powered and connected to the SCB-100.</li> </ul> <p>Refer to the following figure for a detailed diagram.</p>
 <p>S6 S5 S4</p> <p>S1 S2 S3</p>	<p><b>MIO with single-ended temperature sensor mode</b>—Move switches S1, S2, S3, S4, S5, and S6 to the positions shown on the left. In this mode:</p> <ul style="list-style-type: none"> <li>• The temperature sensor can be read using AI 0 in referenced single-ended (RSE) mode.</li> <li>• AI 8 is available on a screw terminal.</li> <li>• The signal accessory power LED (DS1) lights when the device is powered and connected to the SCB-100.</li> </ul> <p>Refer to the following figure for a detailed diagram.</p>
 <p>S6 S5 S4</p> <p>S1 S2 S3</p>	<p><b>MIO with differential temperature sensor mode</b>—Move switches S1, S2, S3, S4, S5, and S6 to the positions shown on the left. In this mode:</p> <ul style="list-style-type: none"> <li>• The temperature sensor can be read using AI 0 and AI 8 in differential mode.</li> <li>• The signal accessory power LED (DS1) lights when the device is powered and connected to the SCB-100.</li> </ul> <p>Refer to the following figure for a detailed diagram.</p>
 <p>S6 S5 S4</p> <p>S1 S2 S3</p>	<p><b>Direct feedthrough mode</b>—You can use direct feedthrough mode with a multifunction I/O device.</p> <p>Refer to <i>Using the SCB-100 with Digital I/O and Counter/Timer Devices</i> for configuration information and a detailed diagram.</p>



**Figure 4. MIO Device Modes Switch Settings**

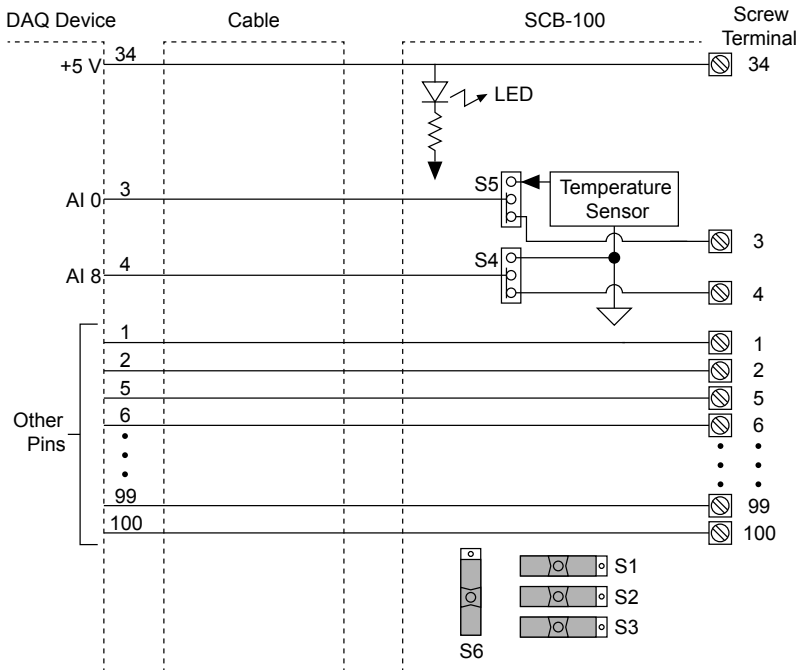

Refer to your device documentation for device signal information.

## Connecting Nonreferenced or Floating Signal Sources to Analog Inputs

A floating signal source is a signal source that is not connected in any way to the building ground system but has an isolated ground-reference point or isolated output. Some examples of floating signal sources are outputs for the following: thermocouples, transformers, battery-powered devices, optical isolators, and isolation amplifiers. The ground reference of a floating signal source must be tied to the ground of the device to establish a local or onboard reference for the signal. If this reference is not established, erratic readings from the board will occur.

- **Differential Inputs**—To provide a return path for the instrumentation amplifier bias currents, floating signal sources must have a 10 k $\Omega$  to 100 k $\Omega$  resistor connected to the AI GND signal line on one input if DC-coupled, or both inputs if AC-coupled. For detailed information on connections to floating signal sources and differential inputs, refer to your device documentation.
- **Single-Ended Inputs**—When measuring floating signal sources, configure the multifunction I/O device for referenced single-ended (RSE) input to supply a ground reference. In this configuration, the negative input of the device instrumentation amplifier

is tied to the analog ground. For detailed information on connections to floating signal sources and single-ended inputs, refer to your device documentation.

## Connecting Ground-Referenced Signal Sources to Analog Inputs

A grounded signal source is connected in some way to the building system ground; therefore, the signal source is already connected to a common ground point with respect to the device (assuming the host computer is plugged into the same power system). Nonisolated outputs of instruments and devices that plug into the building power system fall into this category.

- **Differential Inputs**—Ground-referenced signal sources do not require special components added to the SCB-100 board. For detailed information about connections to ground-referenced signal sources and differential inputs, refer to your device documentation.
- **Single-Ended Inputs**—When measuring ground-referenced signals, the external signal supplies its own reference ground point; the device should not supply one. Configure the device for nonreferenced, single-ended (NRSE) input mode. In this configuration, all of the signal grounds should be tied to AI SENSE, which connects to the negative input of the instrumentation amplifier on the device. Referencing the signal to AI GND can cause inaccurate measurements resulting from an incorrect ground reference. For detailed information on connections to ground-referenced signal sources and single-ended inputs, refer to your device documentation.

## Using the SCB-100 for Thermocouple Measurements

The maximum voltage level generated by thermocouples is typically a few millivolts. Therefore, for best resolution, use an multifunction I/O device with a high gain.

Thermocouples can be measured in either differential or single-ended configurations:

- **Differential Inputs**—Differential configuration has better noise immunity than single-ended configuration. You must install bias resistors when the device is set for differential mode; the device must have a ground reference because thermocouples are floating signal sources.
- **Single-Ended Inputs**—Single-ended configuration has twice as many inputs as differential configuration. Configure the device for referenced single-ended (RSE) inputs.

Cold-junction compensation with the SCB-100 is accurate only if the temperature sensor reading is close to the actual temperature of the screw terminals. Therefore, when reading thermocouples, keep the SCB-100 away from drafts or other temperature gradients such as those caused by heaters, radiators, fans, and warm equipment.

## Optional Input Filtering and Broken Thermocouple Detection

To reduce noise, you can build a simple RC lowpass filter in the breadboard area.

Build broken-thermocouple-detection circuitry by connecting a high-value resistor between the positive input and +5 V. The value of this resistor is relatively unimportant; a few

megaohms or more works fine. You can detect an open or defective thermocouple with a high-value resistor. If the thermocouple opens, the voltage measured across the input terminals rises to +5 V, a value much larger than any legitimate thermocouple voltage.

## Sources of Error

When making thermocouple measurements with the SCB-100 and a device, there are the following possible sources of error:

- **Compensation Error**—Can arise from two sources: inaccuracy of the temperature sensor and temperature differences between the sensor and the screw terminals. The sensor on the SCB-100 is specified to be accurate to  $\pm 0.5$  °C. Minimize temperature differences between the sensor and the screw terminals by keeping the SCB-100 away from drafts, heaters, and warm equipment.
- **Linearization Error**—A consequence of the polynomials being approximations of the true thermocouple output. The linearization error depends upon the degree of polynomial used.
- **Measurement Error**—The result of inaccuracies in the device, including gain and offset. If the device is properly calibrated, the offset error should be zero. The only remaining error is a gain error of  $\pm 0.08\%$  of full range (refer to the device specifications). If the input range is  $\pm 10$  V and the gain is 500, gain error contributes 0.0008 by 20 mV, or 16  $\mu$ V of error. If the Seebeck coefficient of a thermocouple is 32  $\mu$ V/°C, this measurement error adds 0.5 °C of uncertainty to the measurement. For best results, use a well-calibrated device so that offsets can be ignored. Eliminate offset error by grounding one channel on the SCB-100 and measuring the voltage. This value, the offset of the device, then can be subtracted by software from all other readings.
- **Thermocouple Wire Error**—The result of inconsistencies in the thermocouple manufacturing process. These inconsistencies, or nonhomogeneities, are the result of defects or impurities in the thermocouple wire. The errors vary widely depending on the thermocouple type and even the gauge of wire used, but a value of  $\pm 2$  °C is typical.

For best results, use an average of at least 100 readings to reduce the effects of noise.

## Temperature Sensor Output and Accuracy

The SCB-100 temperature sensor outputs 10 mV/°C and has an accuracy of  $\pm 0.5$  °C.

You also can determine the temperature using the following formulas:

$$T_C = 100 \times V_t$$

$$T_K = T_C + 273.15$$

$$T_F = \left[ \frac{9}{5} \times T_C \right] + 32$$

Where  $V_i$  is the temperature sensor output voltage; and  $T_K$ ,  $T_F$ , and  $T_C$  are the temperature readings in degrees Kelvin, degrees Fahrenheit, and degrees Celsius, respectively.



**Note** Use the average of a large number of samples to obtain the most accurate reading. Noisy environments require averaging more samples for greater accuracy.

## Removing the Board

---

You can remove the board from the enclosure to solder components into place. To remove the board, complete the following steps.

1. Disconnect the 100-pin cable from the SCB-100, if connected.
2. Remove the grounding screws on either side of the top cover with a Phillips #1 screwdriver.
3. Open the top cover.
4. Loosen the strain-relief screws with a Phillips #2 screwdriver.
5. Remove the signal wires from the screw terminals.
6. Remove the board mount screws and 100-pin connector screws.
7. Tilt the board up and pull it out of the enclosure.

## Soldering, Desoldering, and Cutting Via Traces on the SCB-100 Board

---

The applications discussed here require you to make modifications to the printed circuit board, usually in the form of adding components or cutting jumpers. Use a low-wattage soldering iron (20 W to 30 W) when soldering to the board.

To desolder on the SCB-100, vacuum-type tools work best. Use care when desoldering to avoid damaging component pads.

Use only rosin-core, electronic-grade solder. Acid-core solder damages the printed circuit board and components.

For each screw terminal, there are one or two vias next to the silkscreen showing the screw terminal number, as shown in the [SCB-100 Parts Locator Diagram](#), number 8. The vias are shorted to the screw terminal so you can solder a component to the via to connect it to the screw terminal signal.

The trace between each pair of vias can be cut if needed.

## Specifications

---

The following specifications are typical at 25 °C, unless otherwise noted.

# Cold-Junction Sensor

Accuracy	±0.5 °C
Output	10 mV/°C

## Power Requirements

Power consumption (at +5 VDC ±5%), typical	10 mA with no signal conditioning installed
--	---



**Note** Limit the current drawn from the host computer's +5 VDC to 800 mA maximum.

## Physical Characteristics

Screw terminals	
Number	101, including one No Connect (NC)
Wire gauge	14 AWG to 26 AWG
Torque	0.5 N·m to 0.6 N·m (4 in.-lb to 5 in.-lb)
Enclosure dimensions	17.93 cm × 15.37 cm × 4.50 cm (7.06 in. × 6.05 in. × 1.77 in.)
Weight	897 g (1 lb 15.6 oz)
I/O connector	One 100-pin female 0.050 series shielded D-type connector

## Safety Voltages

Maximum voltage	30 V RMS, 42 V peak, 60 V DC
-----------------	------------------------------



**Caution** Do not connect the SCB-100 to signals or use for measurements within Measurement Categories II, III, or IV.



**Attention** Ne connectez pas le SCB-100 à des signaux et ne l'utilisez pas pour effectuer des mesures dans les catégories de mesure II, III ou IV.

## Environmental

Operating temperature	0 °C to 55 °C
Storage temperature	-55 °C to 125 °C
Relative humidity	5% to 90% noncondensing
Maximum altitude	2,000 m
Pollution Degree	2

Indoor use only

## Safety

This product is designed to meet the requirements of the following standards of safety for electrical equipment for measurement, control, and laboratory use:

- IEC 61010-1, EN 61010-1
- UL 61010-1
- CAN/CSA-C22.2 No. 61010-1



**Note** For UL and other safety certifications, refer to the product label, or visit [ni.com/product-certifications](https://ni.com/product-certifications), search by model number or product line, and click the appropriate link in the Certification column.

## CE Compliance

This product meets the essential requirements of applicable European Directives, as follows:

- 2011/65/EU; Restriction of Hazardous Substances (RoHS)

## Product Certifications and Declarations

Refer to the product Declaration of Conformity (DoC) for additional regulatory compliance information. To obtain product certifications and the DoC for NI products, visit [ni.com/product-certifications](https://ni.com/product-certifications), search by model number, and click the appropriate link.

## Environmental Management

NI is committed to designing and manufacturing products in an environmentally responsible manner. NI recognizes that eliminating certain hazardous substances from our products is beneficial to the environment and to NI customers.

For additional environmental information, refer to the *Commitment to the Environment* web page at [ni.com/environment](https://ni.com/environment). This page contains the environmental regulations and directives with which NI complies, as well as other environmental information not included in this document.

## Waste Electrical and Electronic Equipment (WEEE)



**EU Customers** At the end of the product life cycle, all NI products must be disposed of according to local laws and regulations. For more information about how to recycle NI products in your region, visit [ni.com/environment/weee](https://ni.com/environment/weee).

## 电子信息产品污染控制管理办法（中国 RoHS）



**中国客户** National Instruments 符合中国电子信息产品中限制使用某些有害物质指令 (RoHS)。关于 National Instruments 中国 RoHS 合规性信息，请登录 [ni.com/environment/rohs\\_china](https://ni.com/environment/rohs_china)。(For information about China RoHS compliance, go to [ni.com/environment/rohs\\_china](https://ni.com/environment/rohs_china).)

## Where to Go Next

---

The following documents contain information that you may find helpful as you use this document:

- Documentation for your DAQ module or device at [ni.com/manuals](https://ni.com/manuals)
- LabVIEW, LabWindows™/CVI™, Measurement Studio, Visual Basic, and ANSI C examples at [ni.com/r/daqmxexp](https://ni.com/r/daqmxexp)
- *Measurement & Automation Explorer Help*
- *NI-DAQmx Help*

## Worldwide Support and Services

---

The NI website is your complete resource for technical support. At [ni.com/support](https://ni.com/support), you have access to everything from troubleshooting and application development self-help resources to email and phone assistance from NI Application Engineers.

Visit [ni.com/services](https://ni.com/services) for information about the services NI offers.

Visit [ni.com/register](https://ni.com/register) to register your NI product. Product registration facilitates technical support and ensures that you receive important information updates from NI.

NI corporate headquarters is located at 11500 North Mopac Expressway, Austin, Texas, 78759-3504. NI also has offices located around the world. For support in the United States, create your service request at [ni.com/support](https://ni.com/support) or dial 1 866 ASK MYNI (275 6964). For support outside the United States, visit the *Worldwide Offices* section of [ni.com/niglobal](https://ni.com/niglobal) to access the branch office websites, which provide up-to-date contact information.

Information is subject to change without notice. Refer to the *NI Trademarks and Logo Guidelines* at [ni.com/trademarks](http://ni.com/trademarks) for information on NI trademarks. Other product and company names mentioned herein are trademarks or trade names of their respective companies. For patents covering NI products/technology, refer to the appropriate location: **Help»Patents** in your software, the `patents.txt` file on your media, or the *National Instruments Patent Notice* at [ni.com/patents](http://ni.com/patents). You can find information about end-user license agreements (EULAs) and third-party legal notices in the `readme` file for your NI product. Refer to the *Export Compliance Information* at [ni.com/legal/export-compliance](http://ni.com/legal/export-compliance) for the NI global trade compliance policy and how to obtain relevant HTS codes, ECCNs, and other import/export data. NI MAKES NO EXPRESS OR IMPLIED WARRANTIES AS TO THE ACCURACY OF THE INFORMATION CONTAINED HEREIN AND SHALL NOT BE LIABLE FOR ANY ERRORS. U.S. Government Customers: The data contained in this manual was developed at private expense and is subject to the applicable limited rights and restricted data rights as set forth in FAR 52.227-14, DFAR 252.227-7014, and DFAR 252.227-7015.

© 1995—2020 National Instruments. All rights reserved.

371224D-01 March 23, 2020