

FEMALE END VIEW

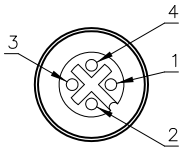

- 1 = N/C
- 2 = N/C
- 3 = BROWN
- 4 = BLUE



SPECIFICATIONS

CONTACT CARRIER MATERIAL/COLOR	NYLON or PUR/YELLOW
MOLDED HEAD MATERIAL/COLOR	THERMOPLASTIC PUR/YELLOW
CONTACT MATERIAL/PLATING	BRASS/GOLD
COUPLING NUT MATERIAL/PLATING	BRASS/NICKEL
RATED CURRENT [A]	4.0 A
RATED VOLTAGE [V]	250 V
OUTER JACKET MATERIAL/COLOR	PVC/GREY
CONDUCTOR INSULATION MATERIAL	PVC
NUMBER OF CONDUCTORS [AWG]	2x20 AWG
TEMPERATURE RANGE	-40°C to +105°C (-40°F to +221°F)
PROTECTION CLASS	MEETS NEMA 1,3,4,6P AND IEC IP67

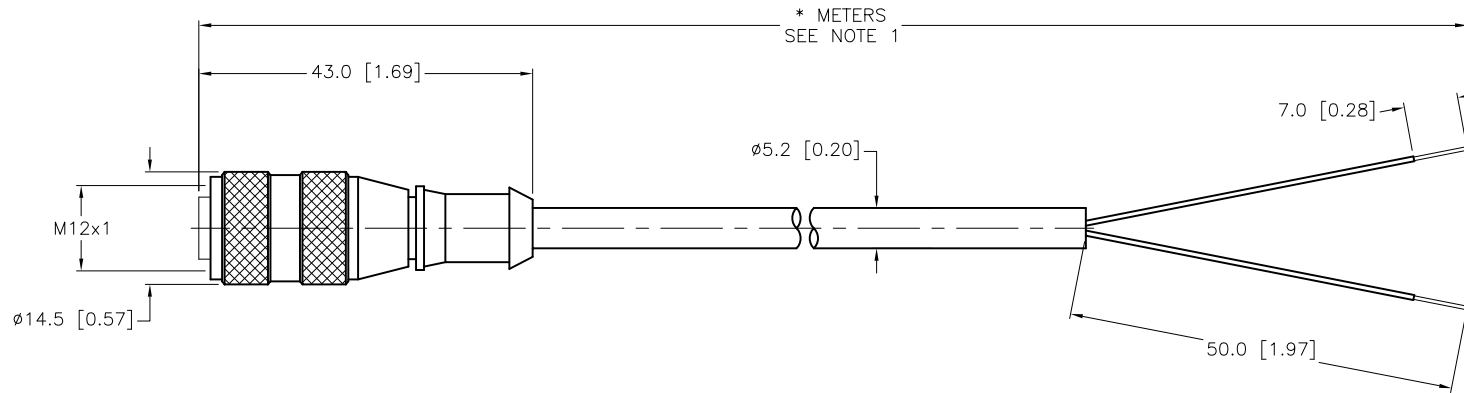

CABLE LENGTH	TOLERANCE
ALL LENGTHS	+ 4% (OR 50mm) OF LENGTH - 0% (OR 0mm) OF LENGTH WHICHEVER IS GREATER
STRIP LENGTH	TOLERANCE
0-7mm	±0.5mm
8-29mm	±1.0mm
30-49mm	±2.0mm
50-69mm	±3.0mm
70-100mm	±4.0mm
OVER 100mm	±5.0mm

SOURCE DRAWING - FOR REFERENCE ONLY

NOTES:

1. "*" INDICATES CABLE LENGTH IN METERS. CONTACT TURCK TO ORDER SPECIFIC LENGTHS.

RELATED DOCUMENTS 1. 2. 3. 4.	3RD ANGLE PROJECTION	THIS DRAWING IS PROPERTY OF TURCK INC. USE OF THIS DOCUMENT WITHOUT WRITTEN PERMISSION IS PROHIBITED.			3000 CAMPUS DRIVE MINNEAPOLIS, MN 55441 1-800-544-7769 (763) 553-7300 (763) 553-0708 fax turck.com	
	TOLERANCES UNLESS OTHERWISE SPECIFIED		DRFT CBM	DATE 10/09/00	DESCRIPTION RK 4.2T-*	
MATERIAL SEE SPECIFICATIONS	0.5 TO 6 ±0.1 6 TO 30 ±0.2 30 TO 200 ±0.3 OVER 200 ±0.4 ANGLES ±1°	DSGN	SCALE 1=1.0	IDENTIFICATION NO.		REV C
FINISH SEE SPECIFICATIONS	ALL INCH DIMENSIONS ARE REFERENCE ONLY	UNIT OF MEASUREMENT MILLIMETER [INCH]		FILE: 777000612		SHEET 1 OF 1
DO NOT SCALE THIS DRAWING						

C	UPDATE COUPLING NUT	JBJ	12/10/02	5582
REV	DESCRIPTION	BY	DATE	ECO NO.