

W  **LC**  **ME**  **TO** **AUST**  **N**



CONNECT

2023 AUSTIN





No Sensors, No Perception— Let's Test Them Properly!

Setu Patel

Offering Manager, ADAS Sensor Test, NI



No Sensors, No Perception— Let's Test Them Properly!

Francisco Saenz

Business Development Manager,
Electronics Production Test, NI

Agenda

The Manufacturing Challenge –
Producing Millions of Units

Testing Cameras

Testing Radars



Support & Services

Going beyond Production Test –
Establishing the Connected Workflow

Autonomy Levels & Sensor Quantity Correlation

The numbers of sensors explodes as autonomy level is increasing

A single controller (i.e. ADC) is required to process data from all the sensors and coordinate actions

Industry Benchmarks		SAE Level 2	(Industry) Level 2+	SAE Level 3	SAE Level 4 (Passenger Vehicle)	SAE Level 4 (Robo-taxi)
	Feature & Functionality	Eyes-on Hands-on Highway assisted driving ACC + Lane Centering	Extended eyes-on Hands-off Highway automated driving ACC + Lane Centering DFM	Eyes-off Hands-off Automated driving ACC + Lane Centering DFM	Eyes-off Hands-off Minds off Passenger vehicle with steering wheel L4 Highway/urban	Mobility-as-a-Service Without steering wheel
	Market Examples (and many more not listed)	Toyota Safety Sense 2.0 Honda Sensing Audi Traffic Jam Assist	GM Super/Hyper Cruise Ford Active Drive Assist Nissan ProPILOT 2.0	Honda Traffic Jam Pilot Mercedes Drive Pilot Volvo Highway Pilot	N/A	Cruise Origin Waymo One Ride-Hailing Service
	Radar	1-5	5	5-7	5-9	17
	Camera	1-5	5-11	7-12	11-18	18
	Lidar	0	Optional	1-5	1-5	5
	Map/Positioning	SD map	SD/HD Map	HD Map	HD Map	HD Map
	Total Vehicle Sensors	2-10	10-16	13-26	17-32	40

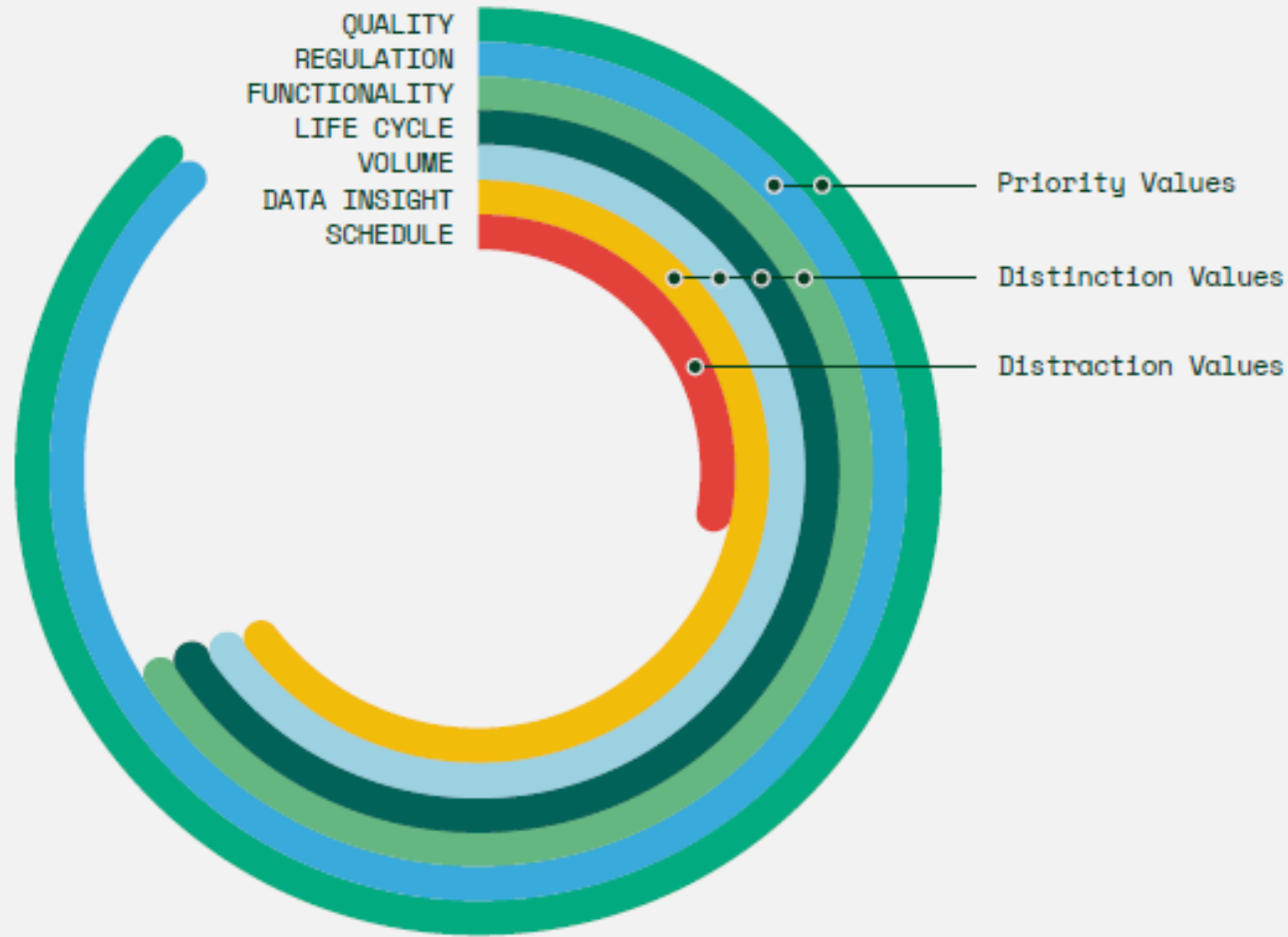

The Quality Driver in the Automotive Industry

Where are you investing your time and resources?



Your Priority:
Quality & Regulation



Your Distinction:
Functionality and Volume



Your Distraction:
Schedule



Quality & Regulation

To differentiate and provide additional performance beyond your competition, you need to regularly revisit your quality standards to ensure compliance

Test coverage is not negotiable & high-quality arena is expected by the industry;

Any process, tool, or proficiency gap that jeopardizes quality standards must be addressed immediately.

Increase need around building product Intimacy - focus more on the testing coverage than in the test infrastructure

2023 set to be the 'year for safer cars' as major regulations will kick in from April

DIPAK K DASH / TNN / Oct 2, 2022, 08:49 IST

Strict EPA Rules for 2027-2032 Vehicles Announced, Garnering a Range of Reactions

These are expected to be the toughest emissions standards yet, a move that should push the industry even more in the direction of EVs.

The European Automobile Manufacturers' Association (ACEA) welcomes the entry into force of the General Safety Regulation (GSR) as part of EU's efforts to halve the number of fatal and serious injuries from traffic accidents in the EU by 2030.



Functionality & Volume

Providing products with new functionalities in the market

Do I have the right domain of expertise?

Optimizing manufacturing high volumes of new and legacy products

How can I increase efficiency?
(throughput, scrap, rework, etc.)



Preparing testing strategy to ensure coverage on new functionalities

Do I have the right tools to accomplish this?

Deploying new product families in the production floor

How do I maintain a mix of legacy and new product volume?

Differentiation can also come through operational excellence!



Schedule

Predictability is more important than pure speed

In today's world scenario, success is measured in hitting deadlines rather than delivery early

Your customers prepare operations based on hard deadlines

- Delivering early might result on a customer not prepared
- Delivering late will affect the whole supply chain

Schedule becomes a distraction to your operations!

Project Kickoff

Hard Deadline

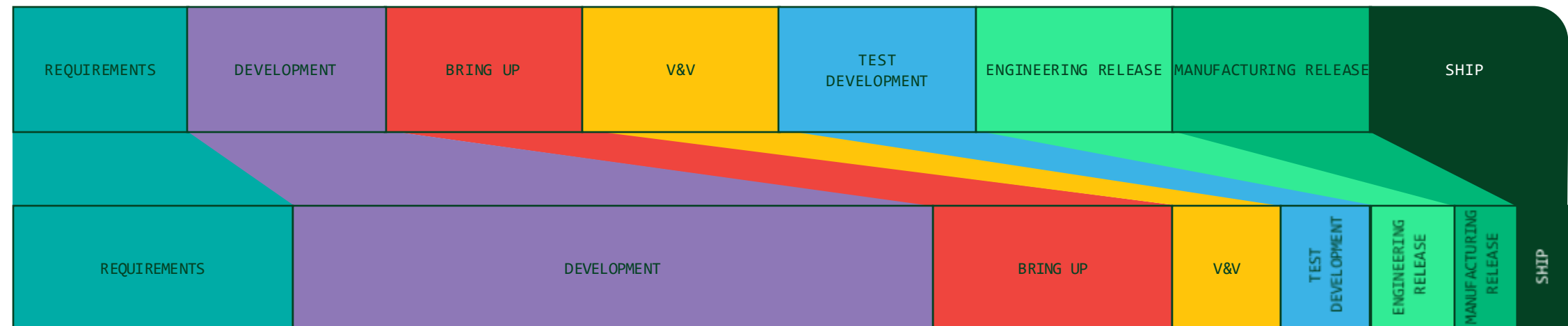

Sometime Later



Ensuring no failures in the field (Quality Driver) will always supersede any priority around scheduling & volume... although we might not always be conscious about it



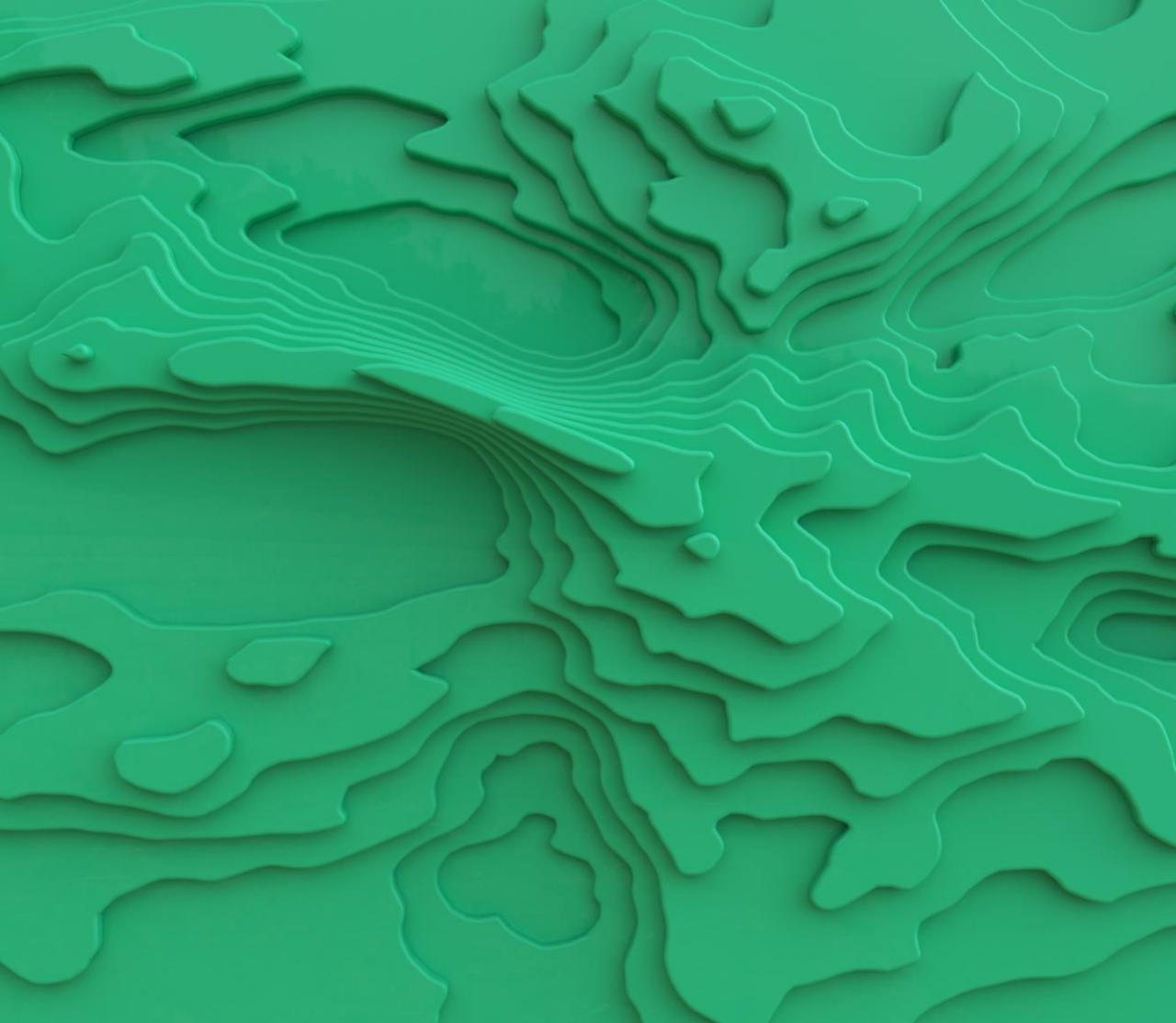

Camera Test

Challenges

Camera Types

- Front View
- Rear View
- Surround View
- Blind Spot
- Night Vision/Infrared
- Driver Monitoring

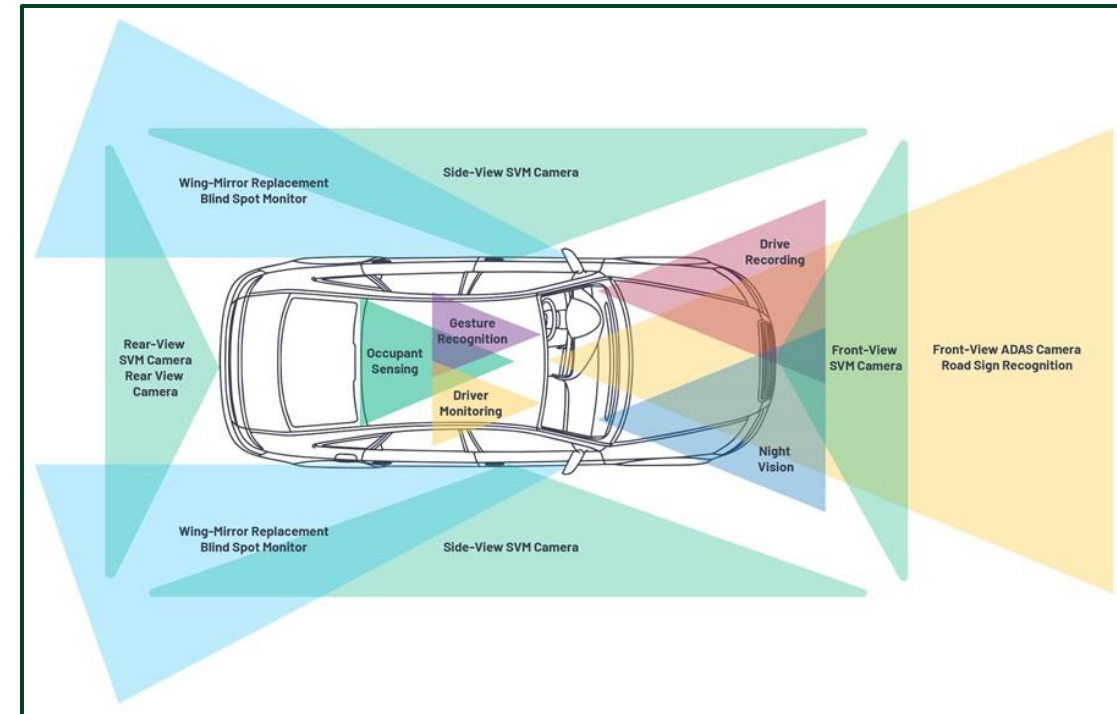

Applications

- Parking
- Automatic braking
- Bird's eye view
- Low-light visibility
- Passenger monitoring
- Lane change assistance
- Obstacle detection

Features

- Exposure control
- Noise reduction
- Image stabilization
- Unique lenses
- Dynamic range
- White balance
- Contrast enhancement
- Field of View

Test Coverage

Manufacturing Processes

Assembly

- Circuit Board Assembly
- Lens Module Integration
- Cable Connections
- Housing Assembly

Testing

- Functional Testing
- Image Quality
- Calibration Adjust
- End-of-Line Testing

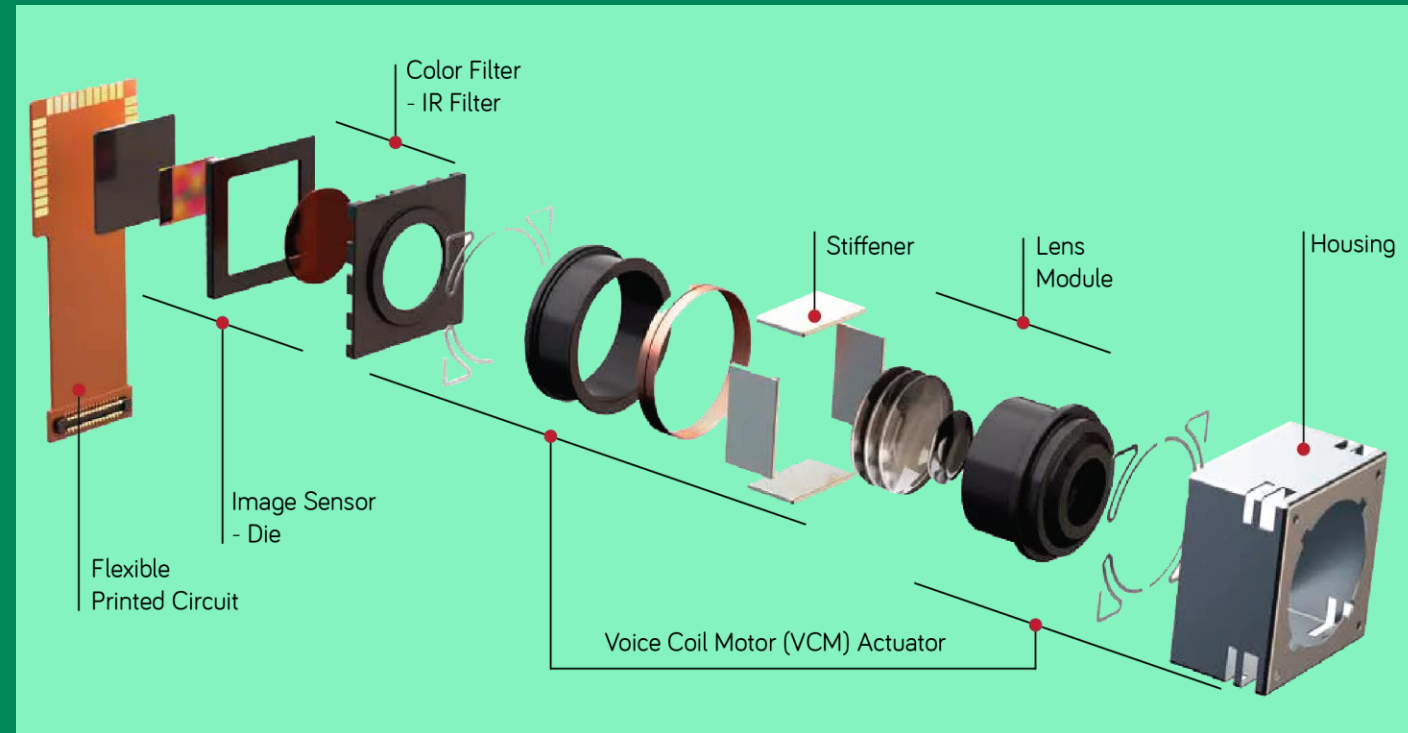
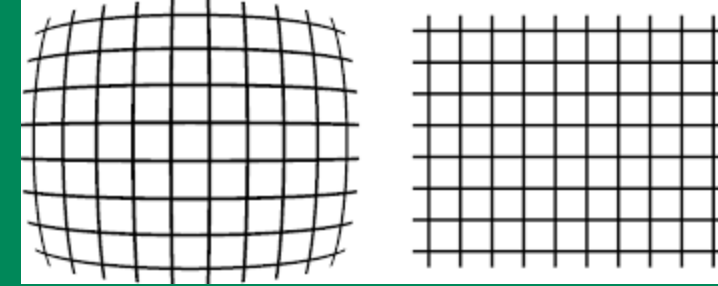

FlexRIO Automotive Camera Module

- 8 channel camera interface
 - **FPD-Link III** (PXIe-1486): DS90UB953 and DS90UB954
 - **GMSL 2** (PXIe-1487): MAX9295A and MAX9296A
- 6 Total Hardware Variants (3 x FPD-Link, 3 x GMSL)
 - **4 inputs & 4 outputs** – In-Vehicle Data Logging (Tap mode)
 - **8 inputs** – In-Vehicle Data Logging, Camera Test
 - **8 outputs** – HIL, Lab-Based Playback, ECU Test (*coming in 2021*)
- **Power over Coax** support
 - 400mA @ 12V per channel (internal power)
 - External power connector for user provided power or load (9-30V @ 800mA max per channel)
 - GMSL 2 or FPD-LINK III compatibility
- **Backchannel communication** support for GPIO
- **User programmable FPGA**
 - Xilinx Ultrascale+ FPGA (KU11P)
 - 4GB DRAM
 - PCIe Gen 3x8 interface to host (~7GB/s)



PXIe-1486: **FPD-Link III**
PXIe-1487: **GMSL 2**

PXle-1488

Features:

- 2 Slot PXle Module
- FPD-Link IV Interface
 - DS90UB791 & DS90UB9702 SerDes
- HFM® - High-Speed FAKRA-Mini Connector
- External Power Connector (same as PXle-1486)
- KU11P FPGA with 4 GB DRAM and PCIe Gen 3x8 (same as PXle-1486)
- 8 Input, 8 Output, and 4 Input / 4 Output variants (same as PXle-1486)

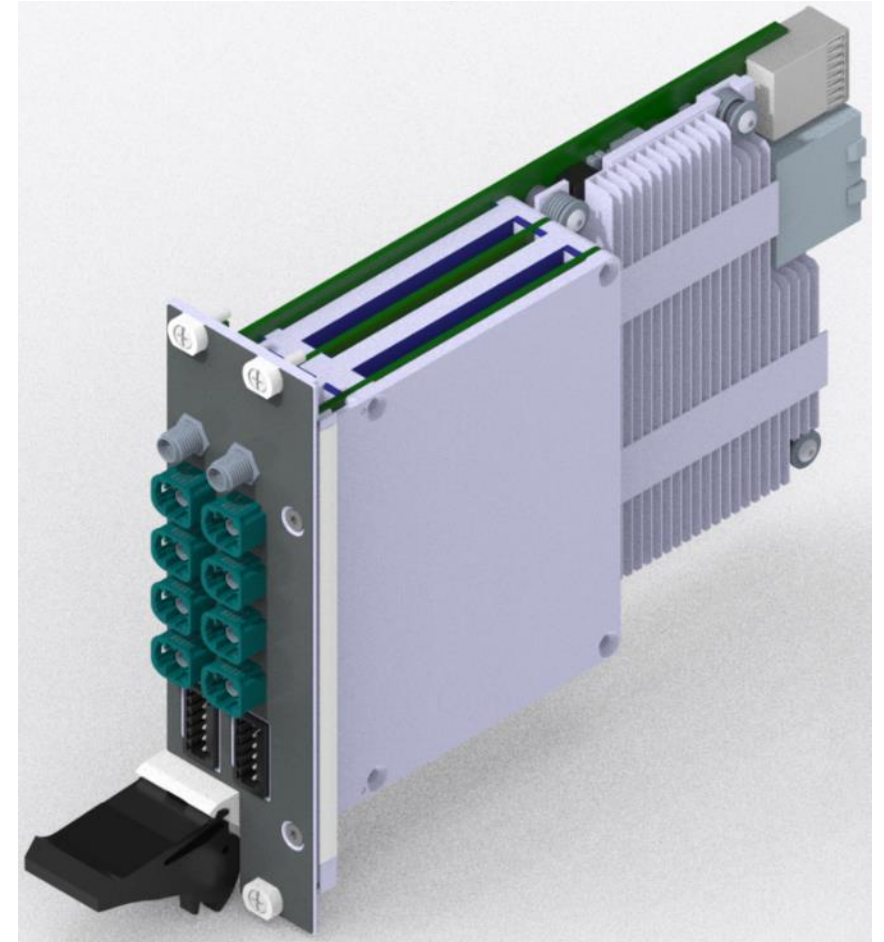
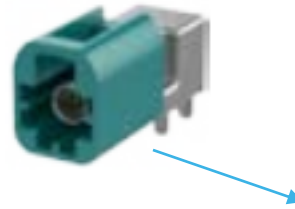

Support:

- NI FlexRIO Integrated IO 22.x
- Windows & NI Linux RT
- Equivalent Getting Started Experience as PXle-1486

Other Details:

- Release Target Q2 2023
- Target Price: \$17k

PXle-1489

Features:

- **1 Slot** PXle Module
- GMSL3 Interface
 - MAX96792A & MAX96793 SerDes
- HFM® - High-Speed FAKRA-Mini Connector
- External Power Connector (same as PXle-1487)
- KU11P FPGA with 4 GB DRAM and PCIe Gen 3x8 (same as PXle-1486)
- **4 Input, 4 Output, and 2 Input / 2 Output** variants

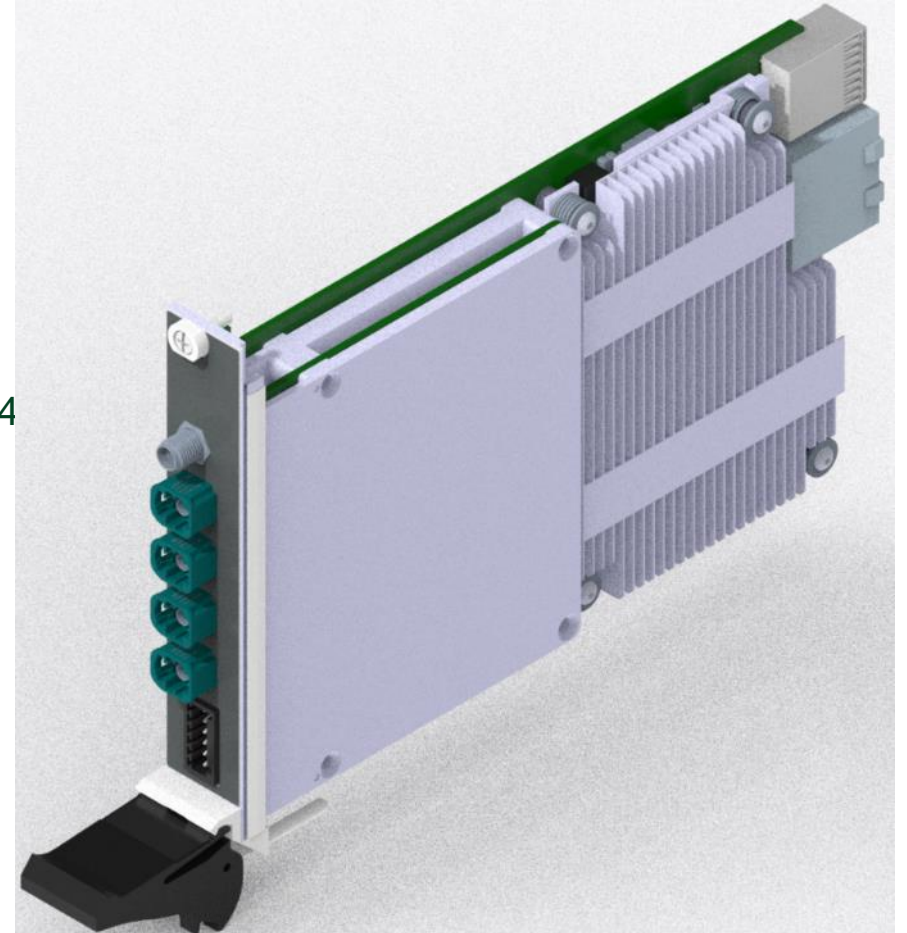

Support:

- NI FlexRIO Integrated IO 22.x
- Windows & NI Linux RT
- Equivalent Getting Started Experience as PXle-1486

Other Details:

- Release Target Q3 2023
- Target Price: \$8.5k

High-Performance 300 W PXI Power Instruments

Primary Application Targets:

- Power electronics validation & test
- General semiconductor & electronics test

PXIe-4151 300 W Power Supply:

- 1 channel, 2 PXI slots
- Up to 20 V and 25 A (e.g. 20 V, 15 A or 12 V, 25 A)

PXIe-4051 300 W E-load:

- 1 channel, 3 PXI slots
- Up to 60 V and 40 A (e.g. 60 V, 5 A or 7.5 V, 40 A)

Common Features:

- Simultaneous I & V measurements
- DMM-like measurement accuracy
- 1.8 MS/s sample rate & 100 kS/s update rate



PXIe-4151



PXIe-4051

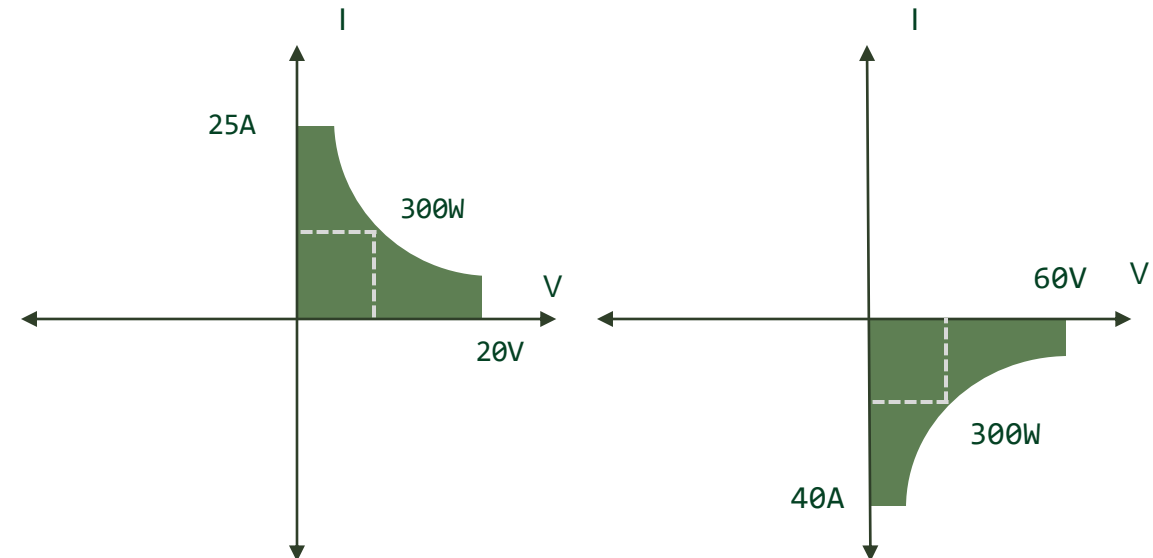



Production System

PXI-Based System

- Frame Grabber
 - PXIe 14xx series
- Power Supply
 - RMX 41xx series
- Power Measurements
 - PXI 40xx series

Software

- Software based camera configuration
- Image quality testing

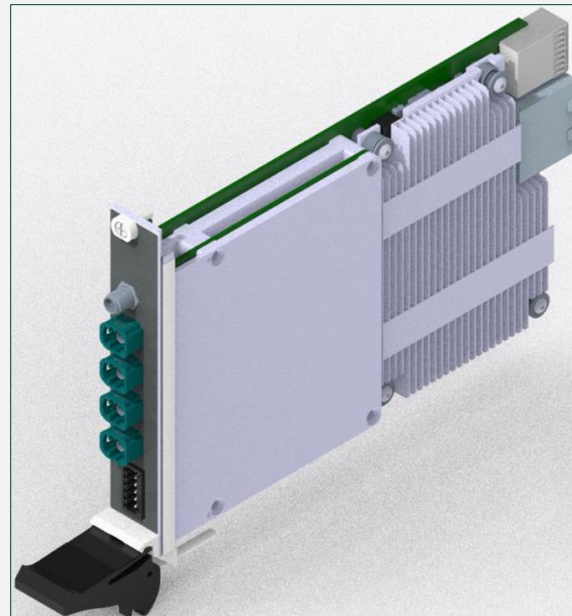

What's Next?..

Cycle Time Optimization

- Parallel I2C Communication
- Camera Hot-Unplug API indicator

Cost Optimization

- Single Slot frame grabber
- Lower Channel count
- Next Gen PXI-based powersupply
 - DMM level measurement accuracy

Software

- FPGA base ISP
- Production Software Suite

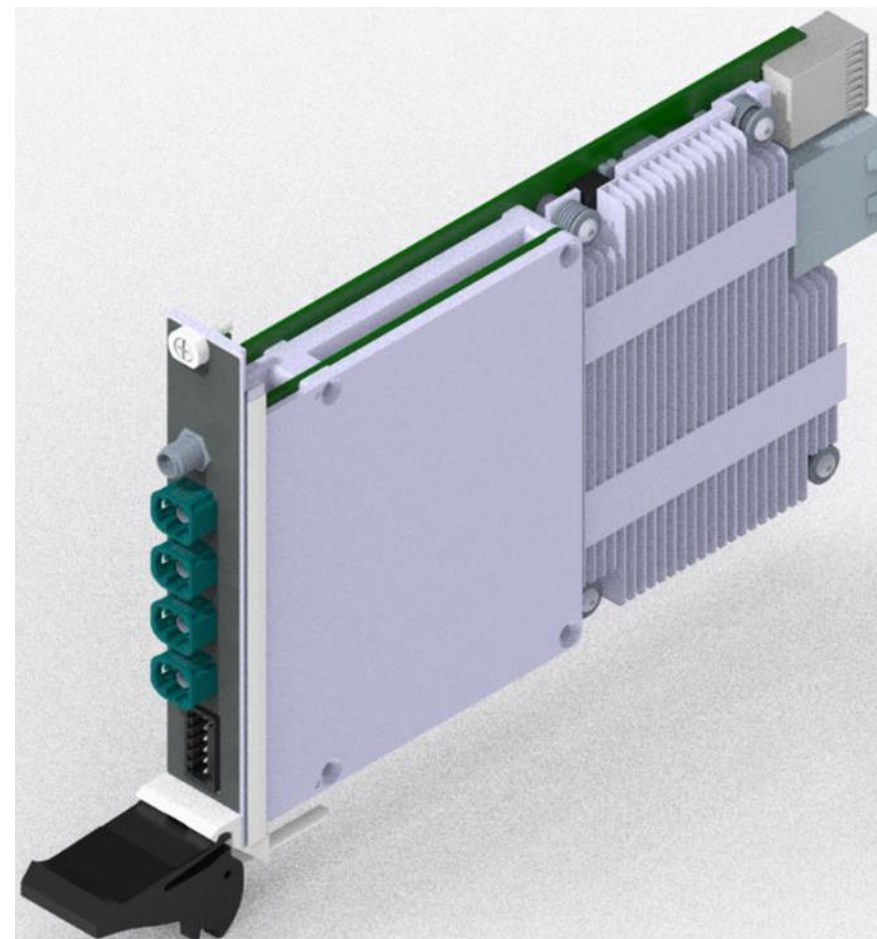

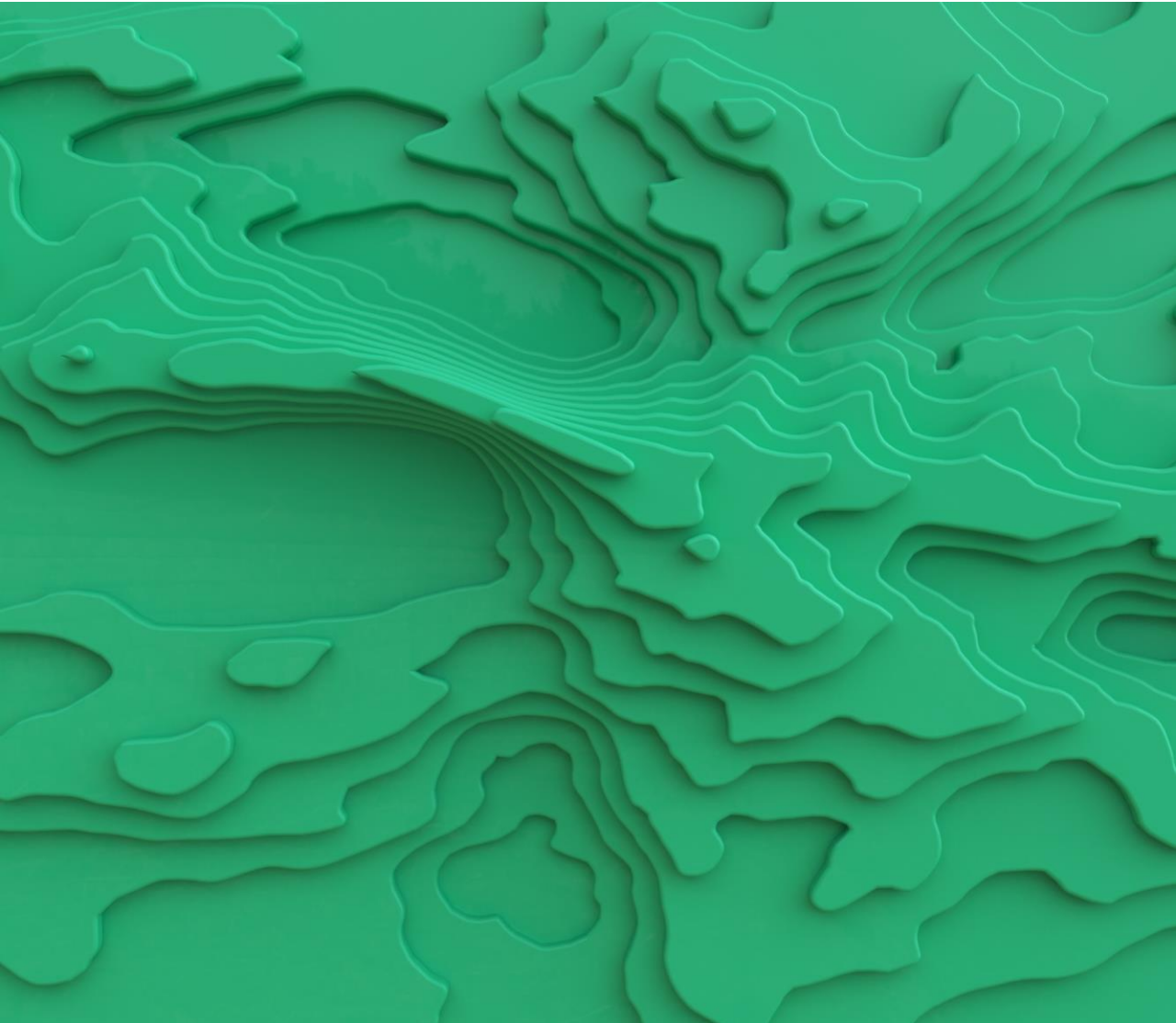

Radar Test

Radar Evolution Equals More Challenging Test



ANTENNAE DESIGN



UNIVERSALITY



RANGE RESOLUTION
BANDWIDTH



4D IMAGING RADAR



PROTOTYPE AVAILABILITY

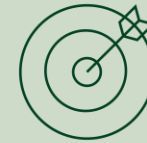

SENSOR PERFORMANCE

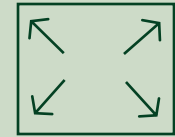

CHAMBER'S FOOTPRINT



SIMULATION AND PARAMETRIC TEST



TEST SETUP



SAFETY REQUIREMENTS



BLACK BOX TEST

Radar Test Approaches

Open Air/Road Test



PROS

- Most realistic scenario
- Validates robustness

CONS

- Poor repeatability
- Difficult to debug/isolate issues

Large Anechoic Chamber



PROS

- Higher accuracy

CONS

- Expensive (CapEx, test time)
- Static scenarios have poor test coverage

Radar Object Simulator



PROS

- Flexible and parametric scenarios
- High repeatability

CONS

- Simplified model compared to real world

OTA Radar Object Emulation Systems

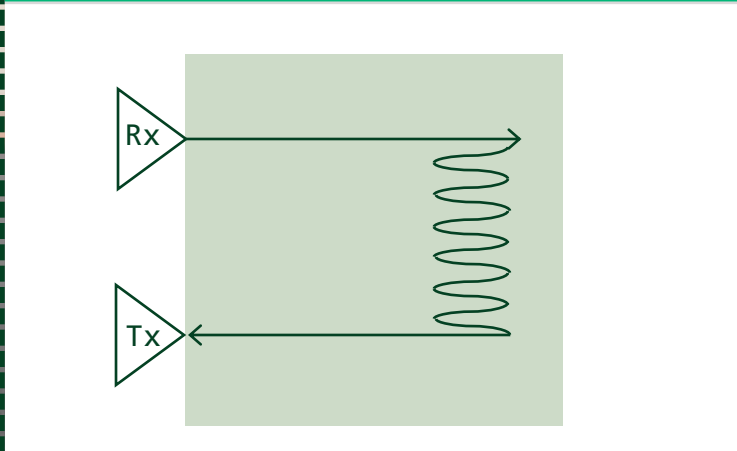
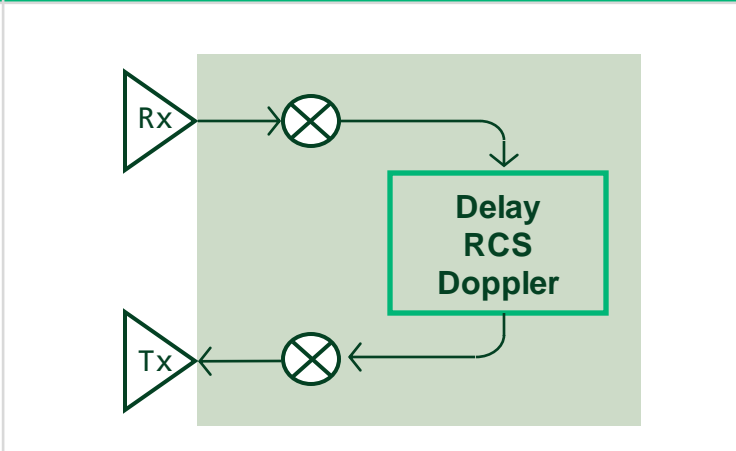
Corner Reflector	Passive Delay Line	Active Radar Object Simulator
		
<p>Fixed Distance Fixed RCS</p>	<p>Fixed Long Distance Fixed RCS</p>	<p>Variable Long Distance Variable RCS Variable Doppler Dynamic Moving Object</p>

NI Vehicle Radar Test System (VRTS)

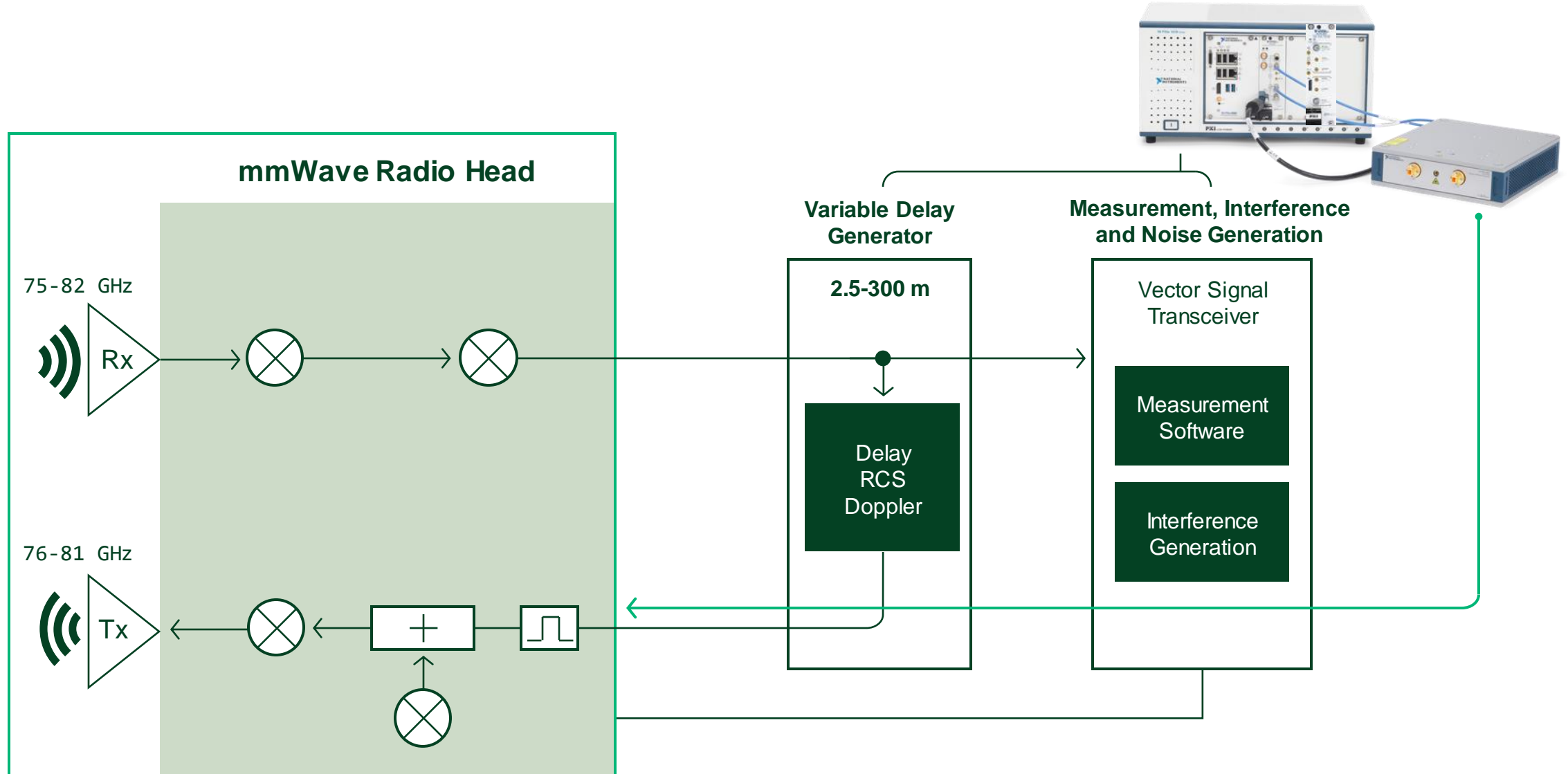



Radar Antenna Configurations Choosing Between Monostatic and Bistatic



PROS



CONS

	PROS	CONS
<p>Bistatic</p>	<ul style="list-style-type: none"> Better isolation Higher gain Easier debugging (e.g., RX or TX) Smaller antennas 	<ul style="list-style-type: none"> Angular deviation in elevation plane Harder to calibrate within the chamber
<p>Monostatic</p>	<ul style="list-style-type: none"> Precise angle simulation Easier to calibrate the position within the chamber Better suited for CATR (compact antenna test range) chambers 	<ul style="list-style-type: none"> Worse isolation / cross talk Lower gain Potential for ghost source due to low TX/RX isolation Larger antenna

Leading Tier 1 Company

Project/Need:

- Bringing new SRR & FLR product families to market with functionality differentiation from their competition
- Growing business with exponential increase in production volumes needed a new approach to radar sensor test to meet goals for quality and throughput
- Global project requiring collaboration between engineering and manufacturing sites around the world



Results:

- Floor space and capital savings through test time reduction by more than 25% while also testing new elevation features of their sensors
- >50 systems deployed between multiple production sites around the world.
- Flexible Production Test systems prepared for existing and new Radar generations.

System Delivery Through Specialized Partners

RND 瑞地测控

Shanghai, China

31 Years of Experience

konrad
... technologies ...

Germany, Austria, UK, US, India and China

27 Years of Experience

NOFFZ
TECHNOLOGIES

Germany, Hungary, Mexico, China, USA

31 Years of Experience

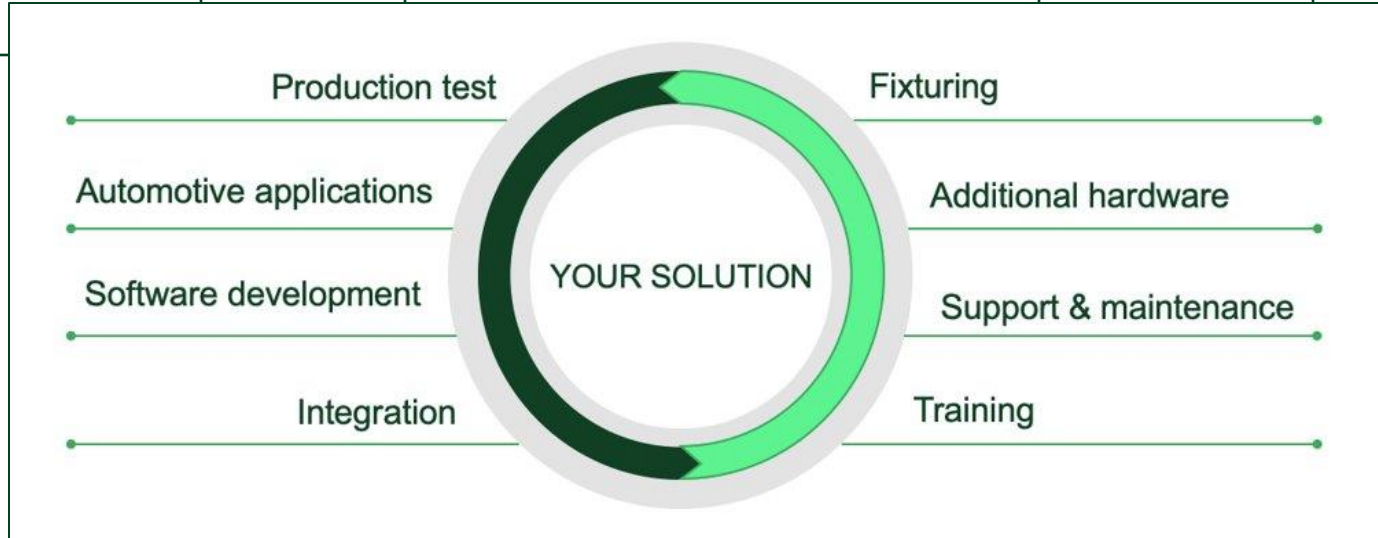

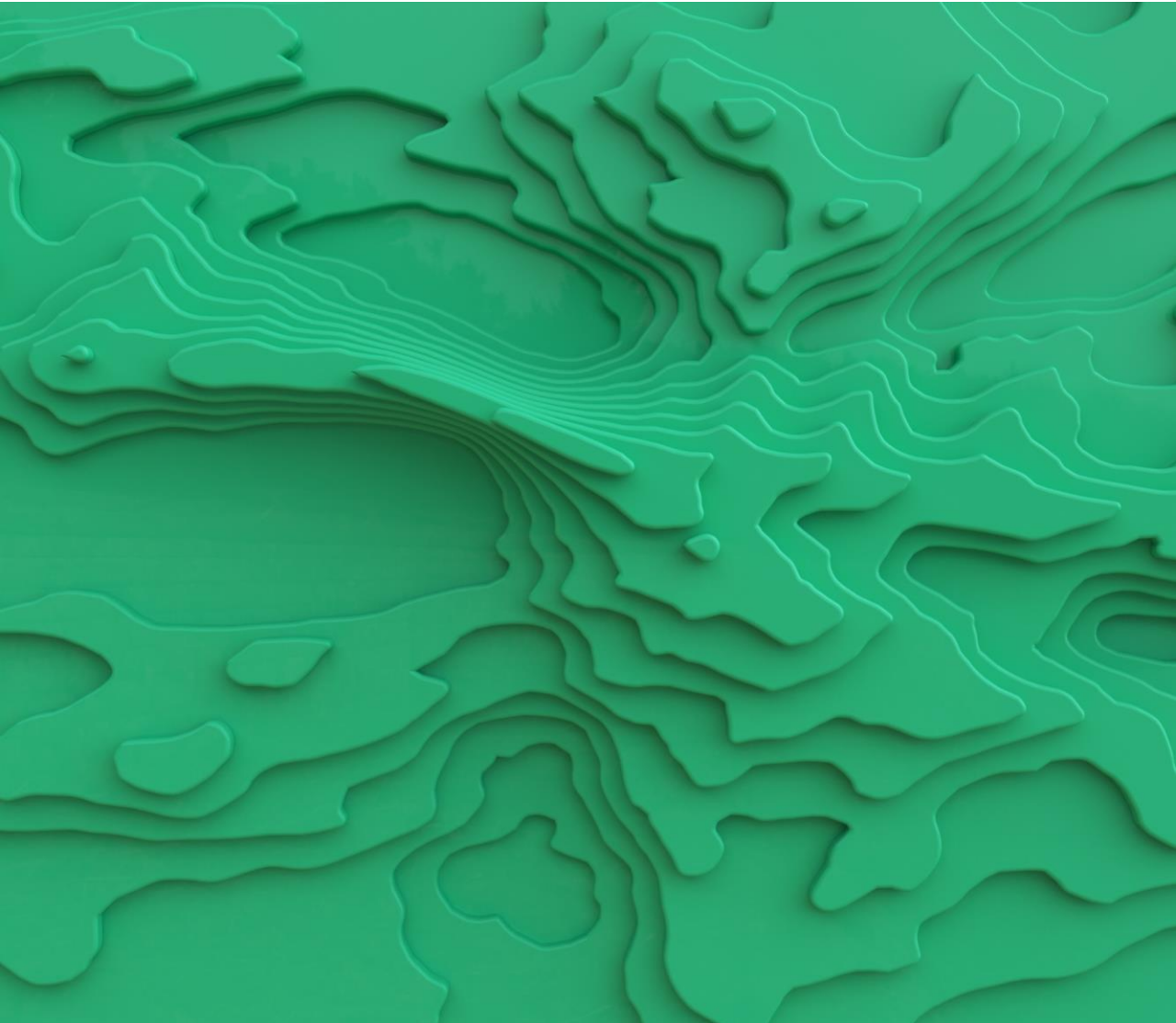

Shared Vision

Vision Zero for Automotive

Zero Fatalities

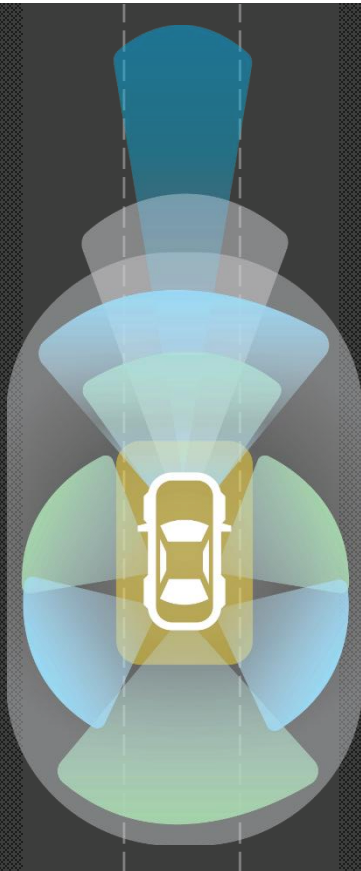

Zero Emissions



Zero Loss

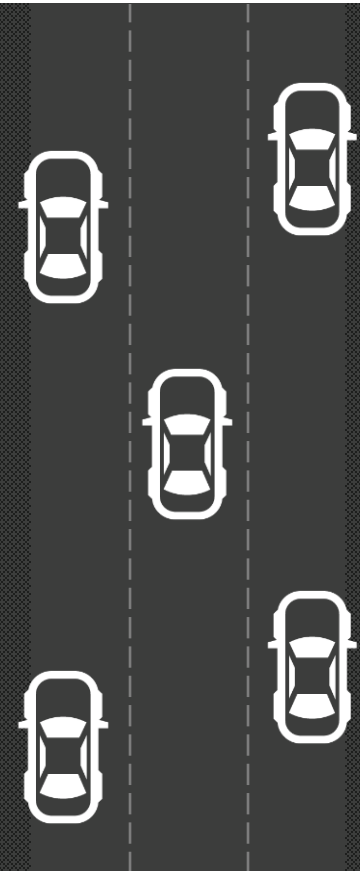

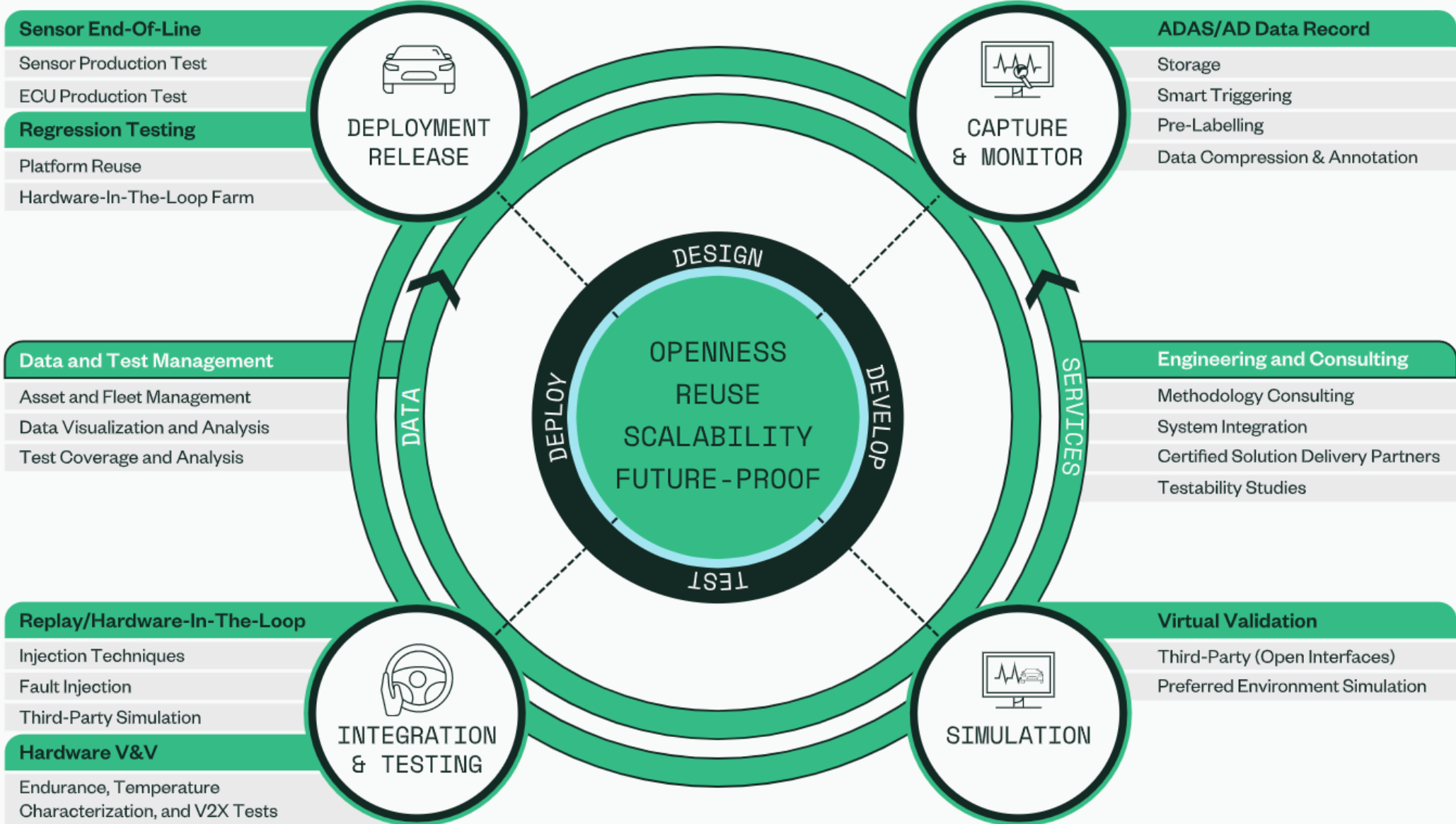

We're committed to your success.

300k+
COMMUNITY USERS

30+
SERVICE CENTERS

900+
SOFTWARE ADD-ONS
AND APPLICATIONS

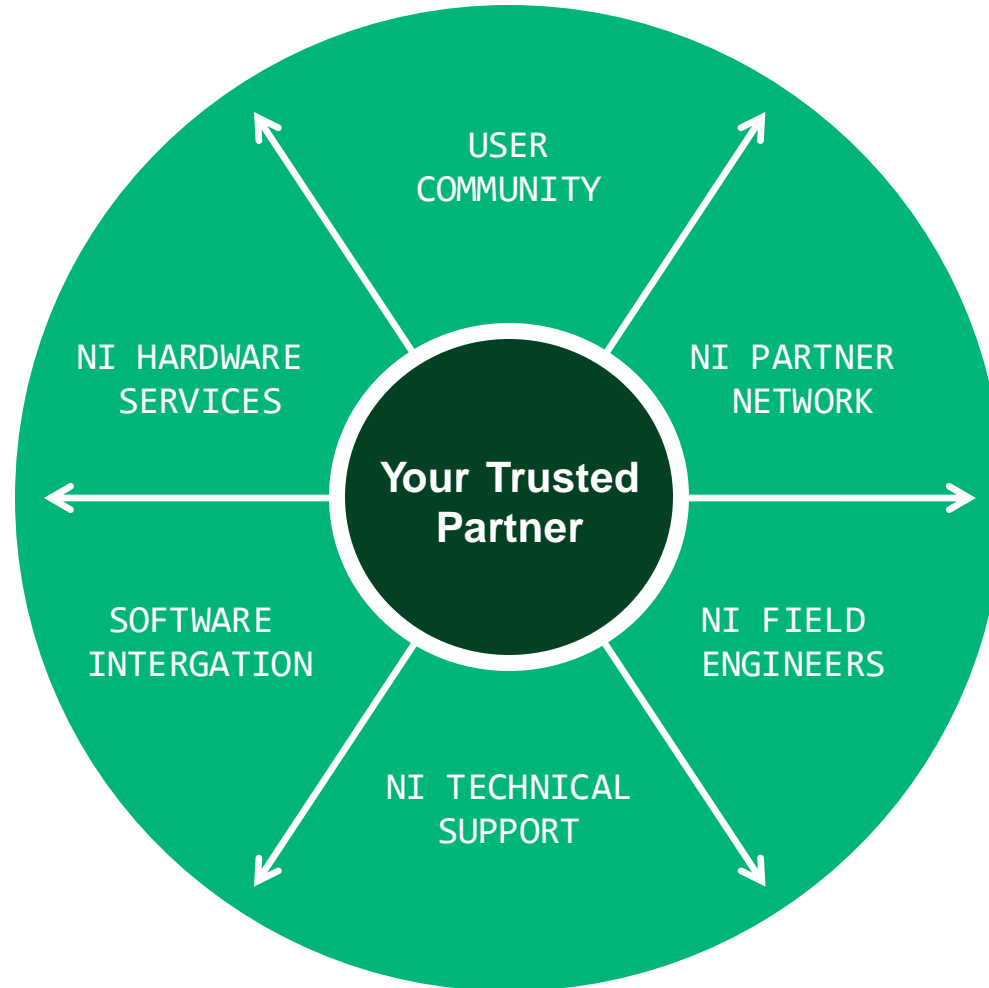

1000+
PARTNERS

700+
FIELD ENGINEERS

700+
SUPPORT ENGINEERS

Question & Answers

Please submit your question through Q/A chat pod.

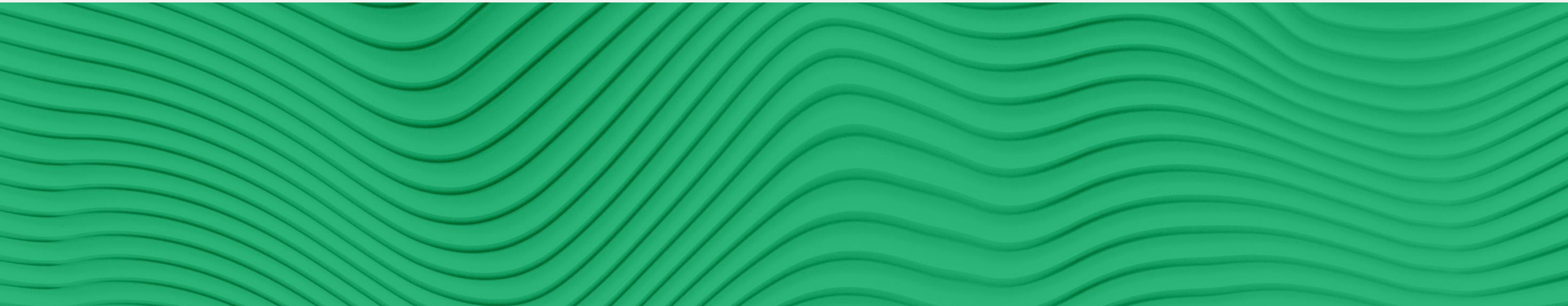
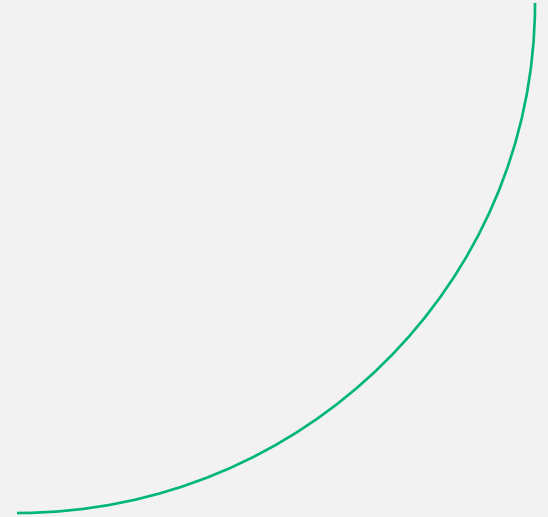

Next Steps

[Download the PDF](#)

[Learn More](#)

[Contact Us](#)

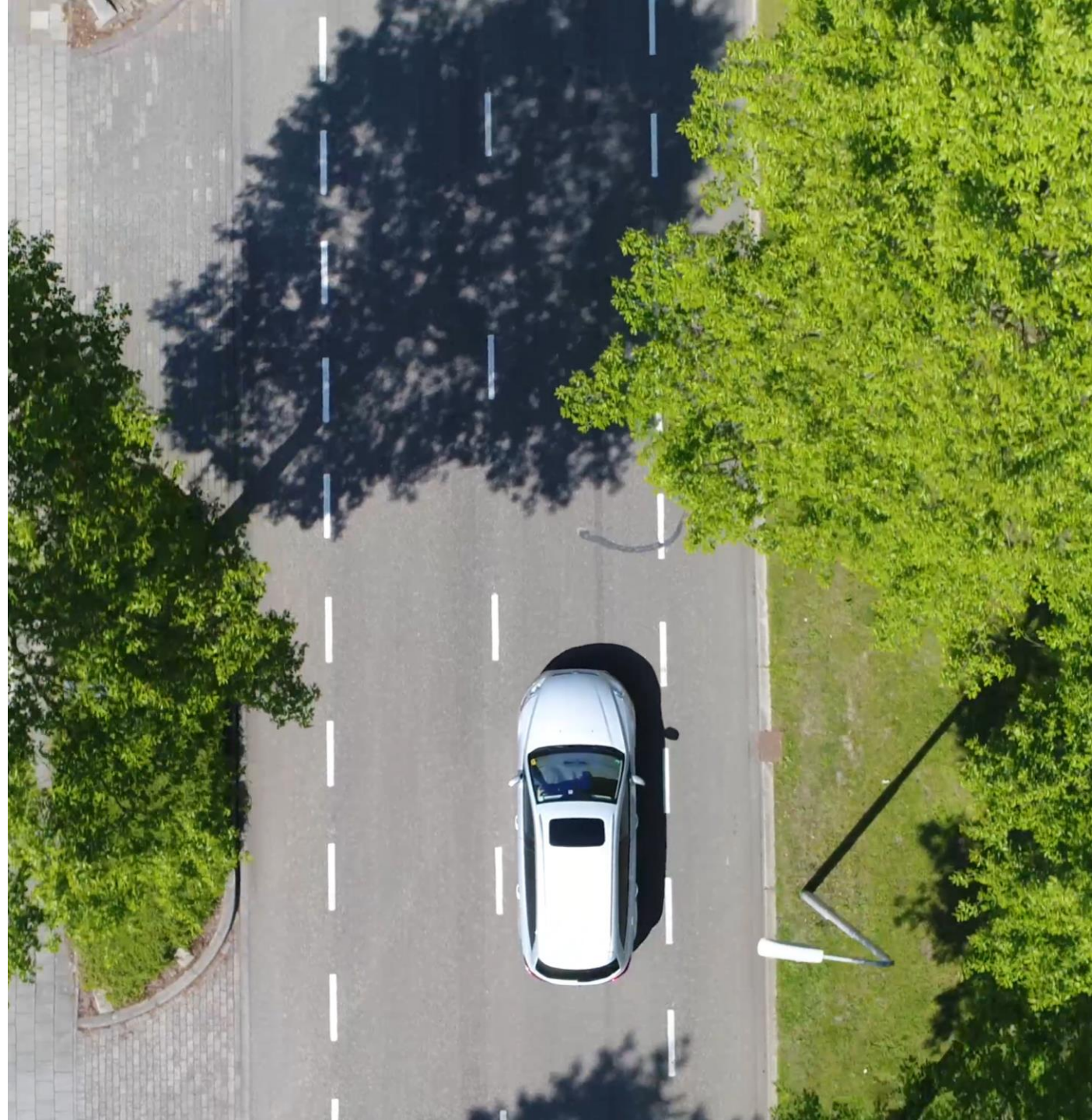



CONNECT

2023 AUSTIN

