

ISOMETRIC VIEW

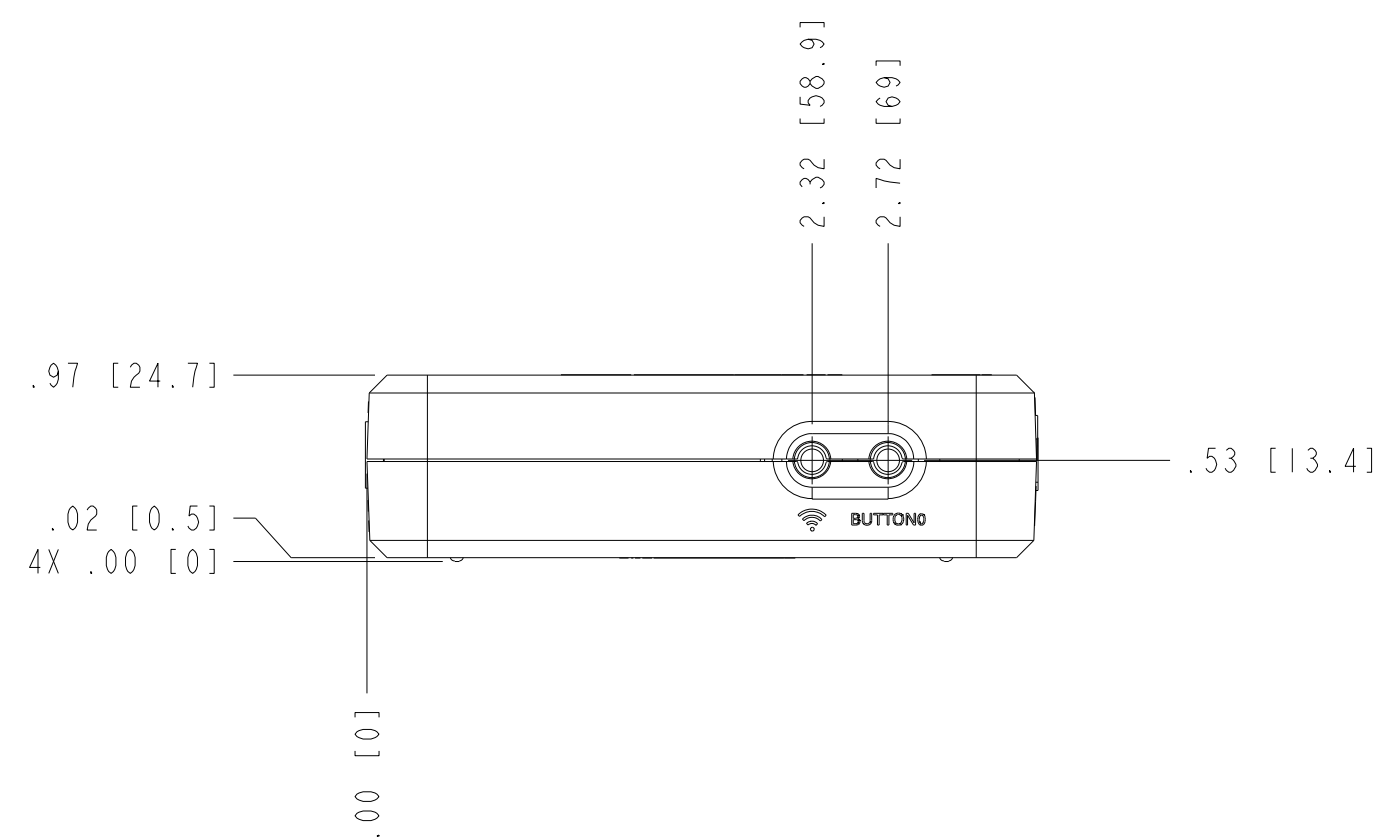
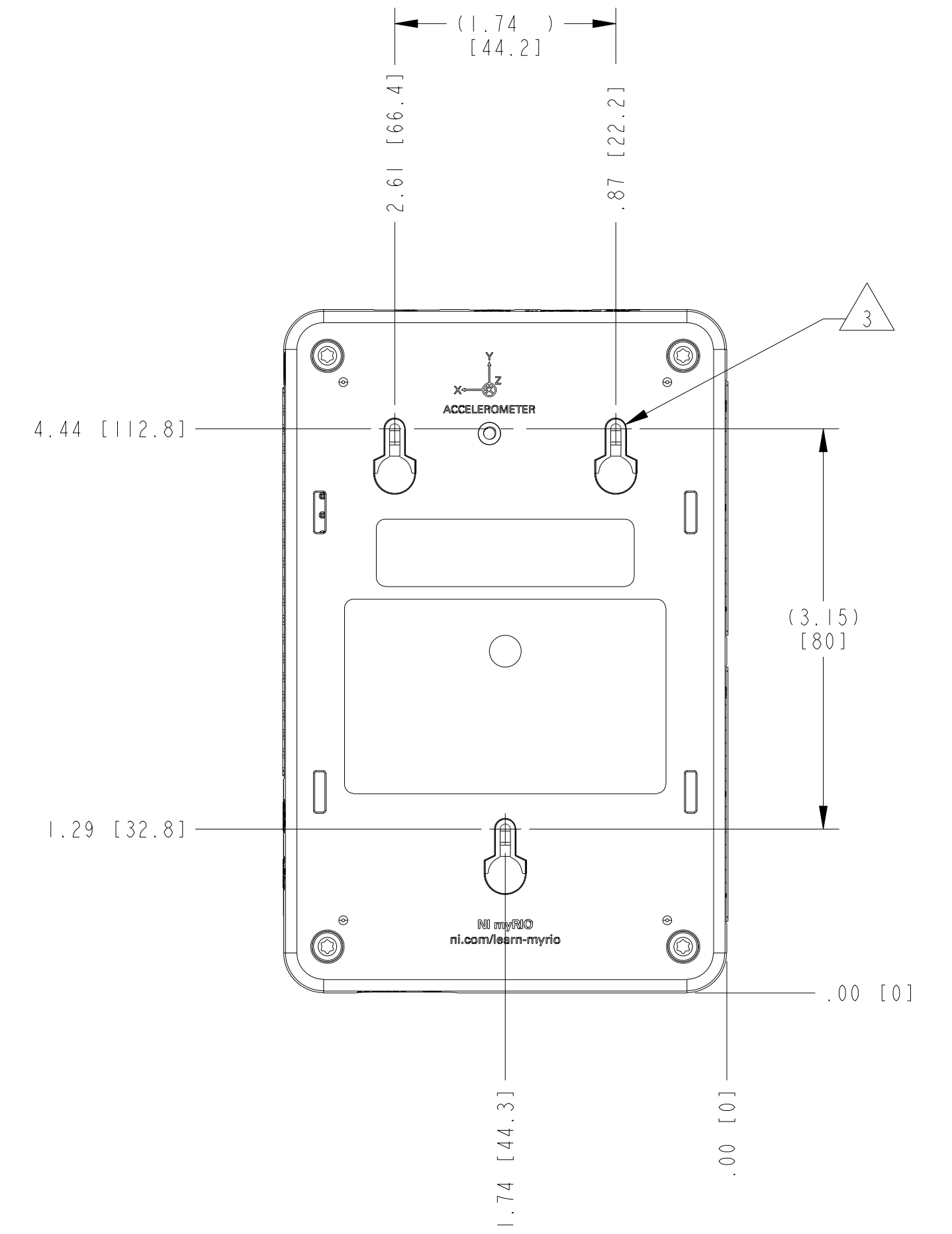
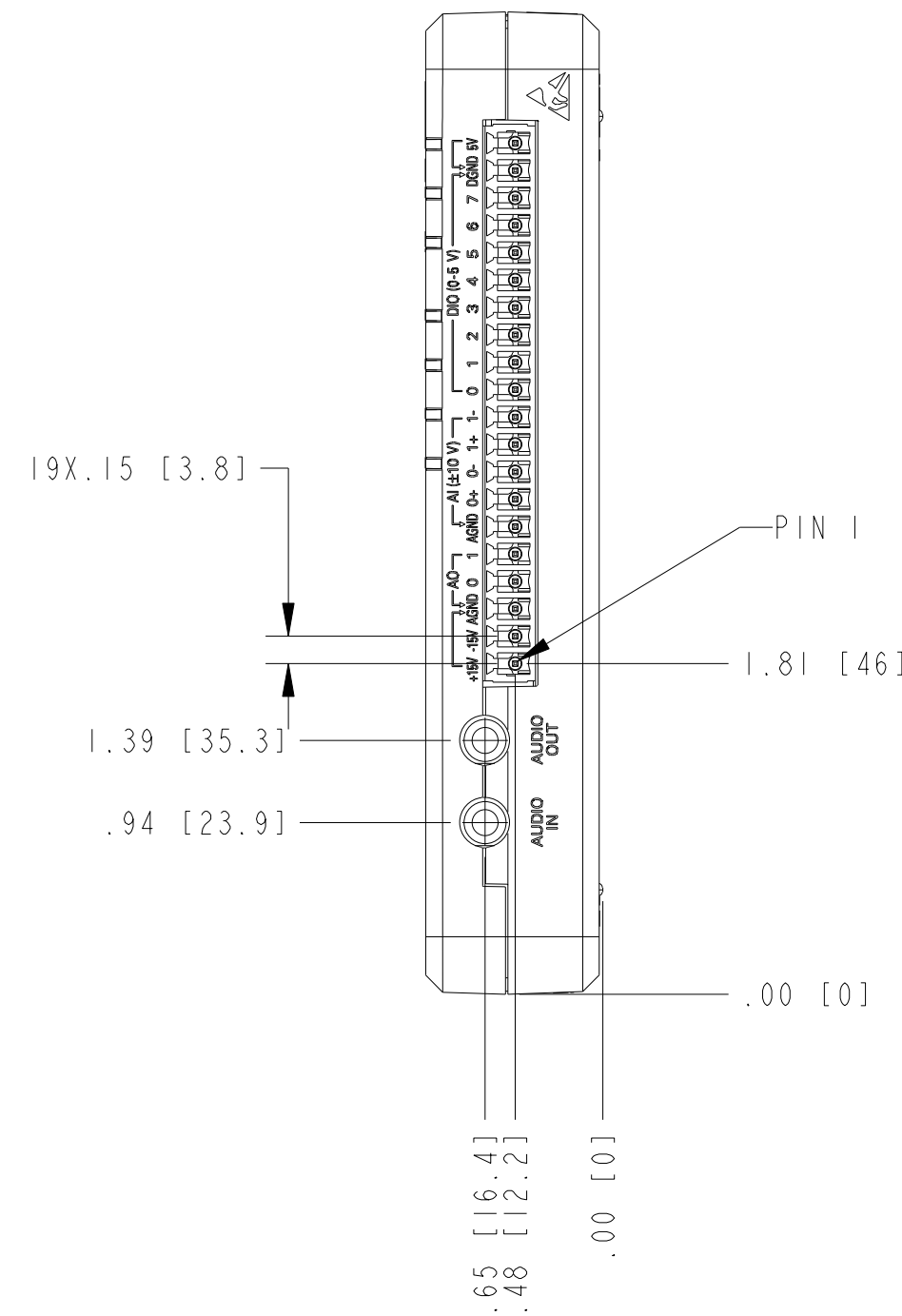
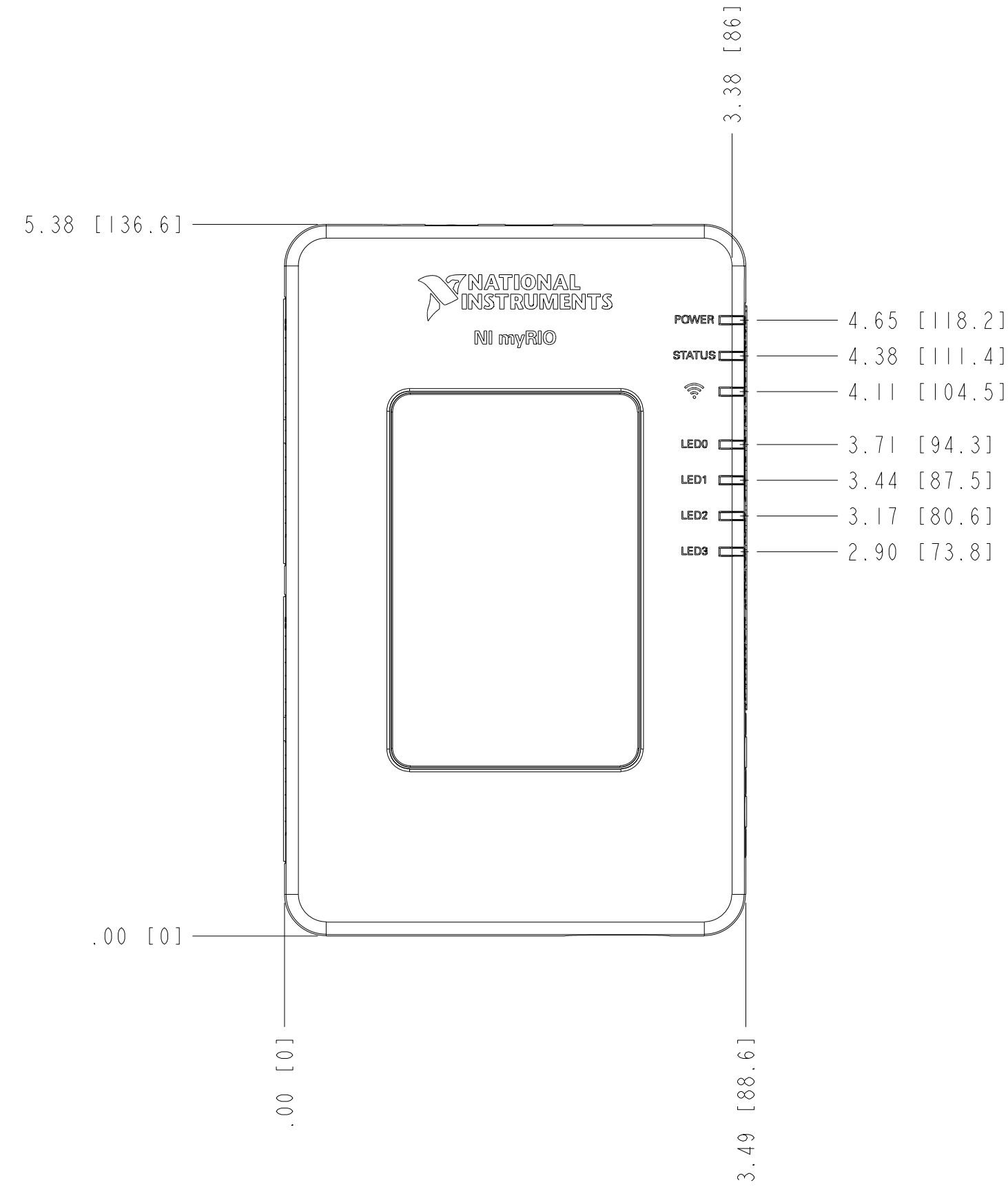
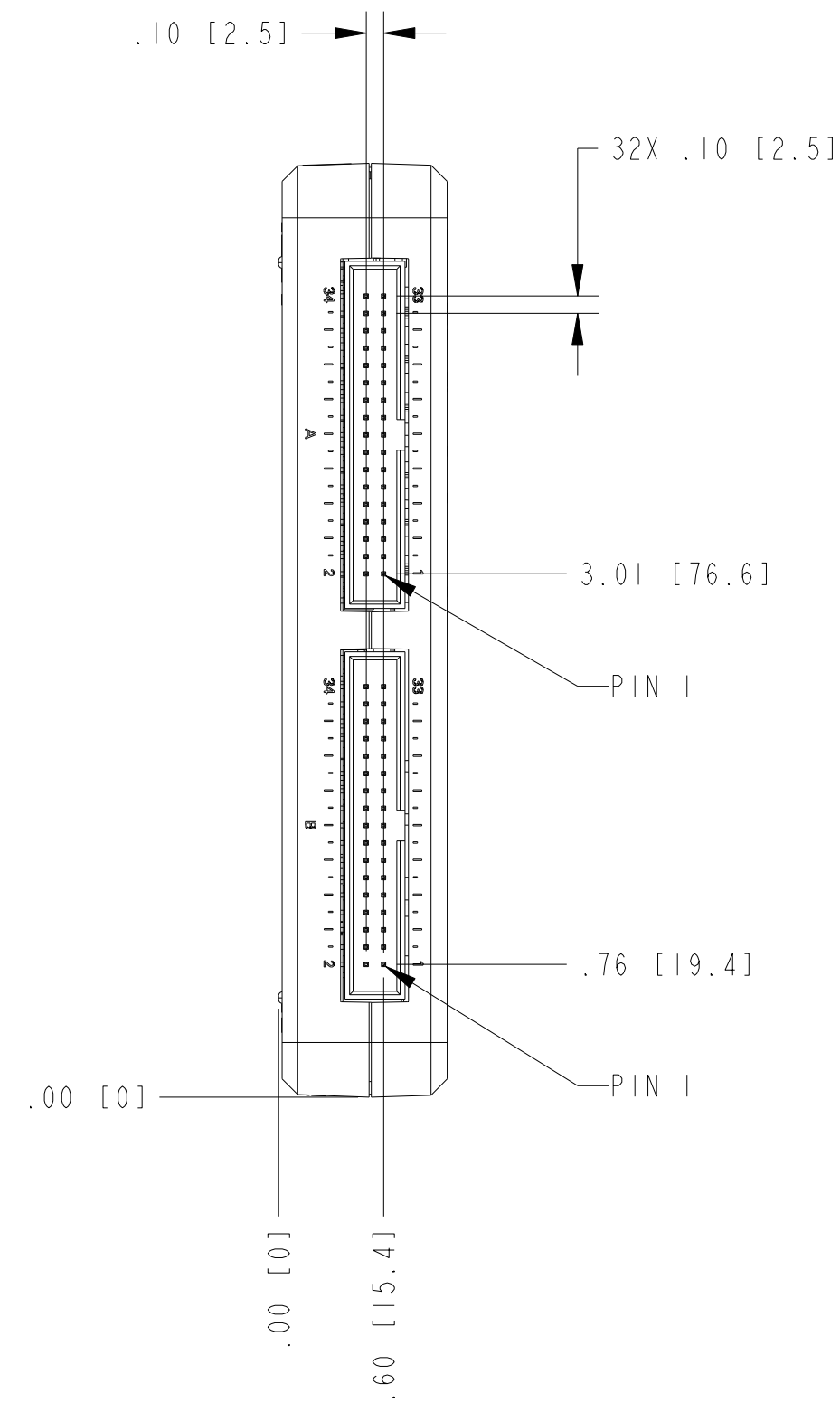
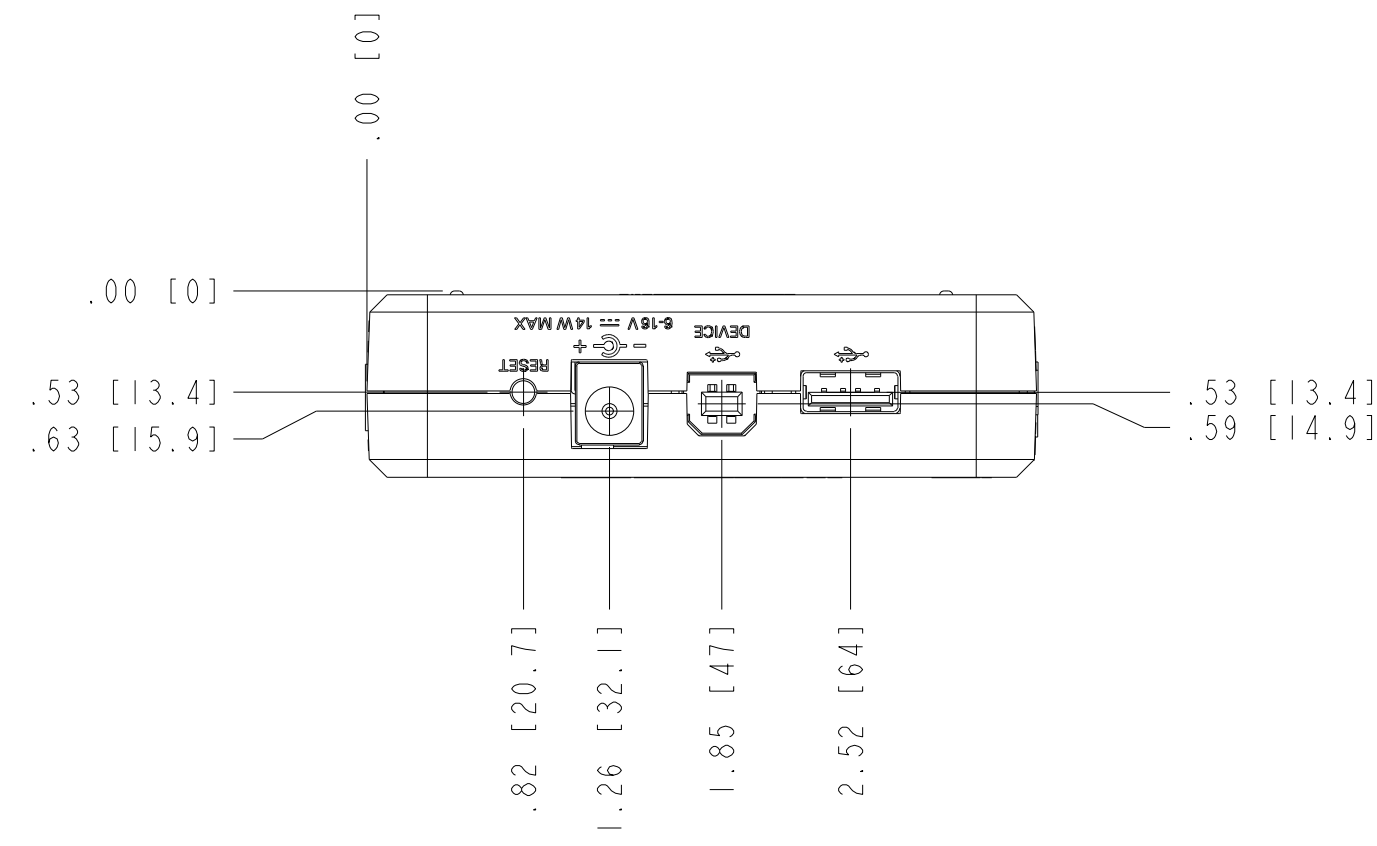

- 4. REFER TO MYRIO DAUGHTERBOARD TEMPLATE FOR DAUGHTERBOARD DESIGN.
 - 3. USE UNC 4-40 OR ISO M3 SIZED SCREW. MOST HEAD STYLES SUPPORTED.
 - 2. DIMENSIONS IN () ARE FOR REFERENCE ONLY.
 - 1. REFER TO PRODUCT MANUAL ON NI.COM FOR MORE DETAILS.
- NOTES: UNLESS OTHERWISE SPECIFIED.

UNLESS OTHERWISE SPECIFIED DIMENSIONS ARE IN INCHES AND (MILLIMETERS). DO NOT SCALE DRAWING THIRD ANGLE PROJECTION 	NATIONAL INSTRUMENTS® AUSTIN, TEXAS	
	TITLE NI myRIO-1900	
	SIZE CODE IDENT NO. MM/DD/YYYY D 7U296 08/12/2013	SCALE: 1/1 SHEET OF 1