

7. REFER TO PRODUCT MANUAL ON NI.COM FOR MORE DETAILS.
4. USER MUST PROVIDE MINIMUM COOLING/VENTING CLEARANCE AS SHOWN. FAILURE TO PROVIDE THIS CLEARANCE MAY RESULT IN CHASSIS OR MODULE THERMAL RELATED FAILURES.
3. NI COMPASS BLUE COLOR.
2. NI COMPASS WHITE COLOR.
1. THERE ARE FOUR HOLES ON EACH SIDE OF CHASSIS FOR MOUNTING PURPOSES.
- NOTES: UNLESS OTHERWISE SPECIFIED.

UNLESS OTHERWISE SPECIFIED, DIMENSIONS ARE IN INCHES AND [MILLIMETERS].	AUSTIN, TEXAS	
	TITLE CUSTOMER DRAWING, CHASSIS ASSEMBLY, PXI-1050	
DO NOT SCALE DRAWING THIRD ANGLE PROJECTION	SIZE CODE IDENT NO   MM/DD/YYYY D   7U296   11/06/2007	
	SCALE: 1/4	SHEET 1 OF 2

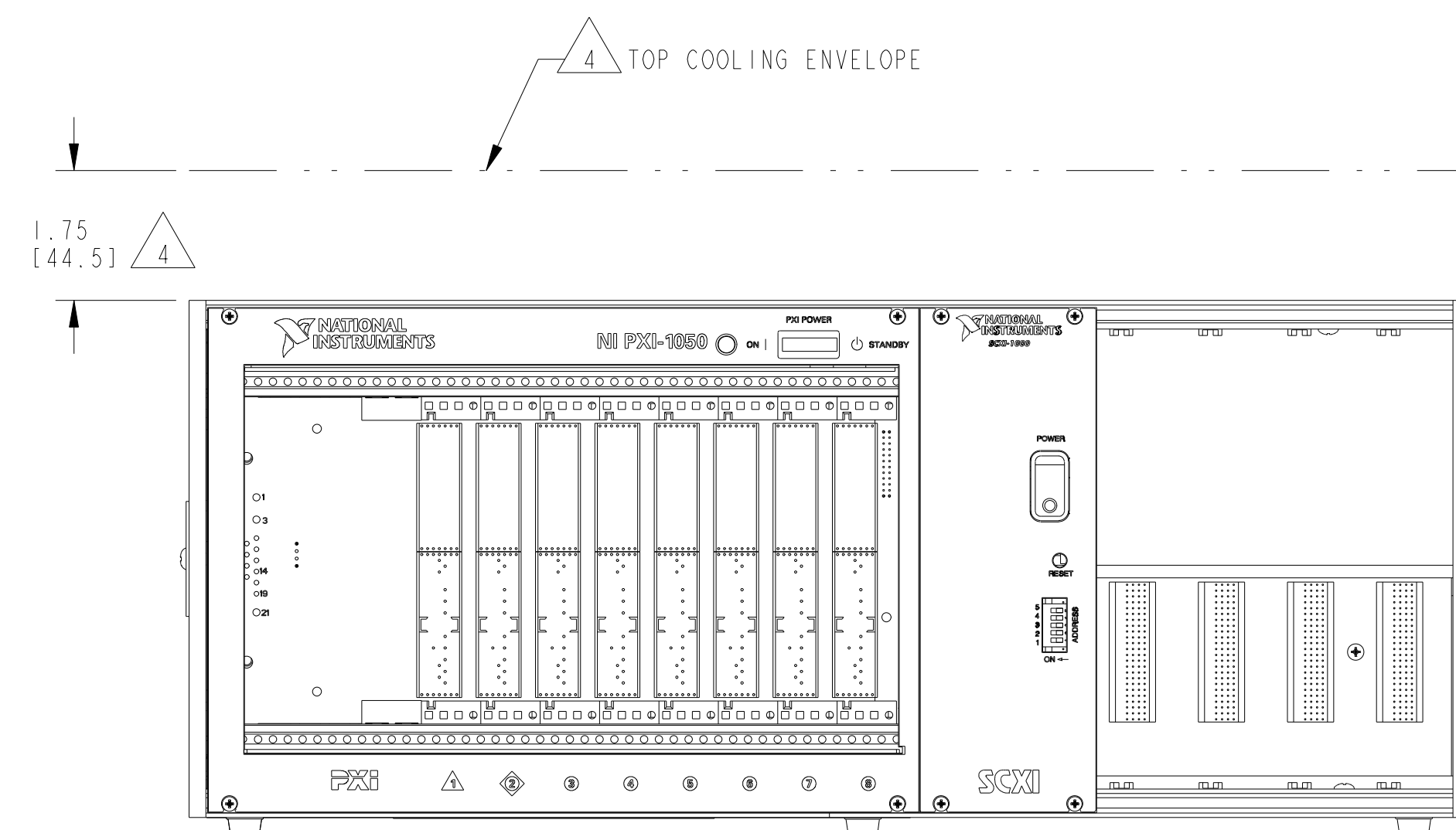
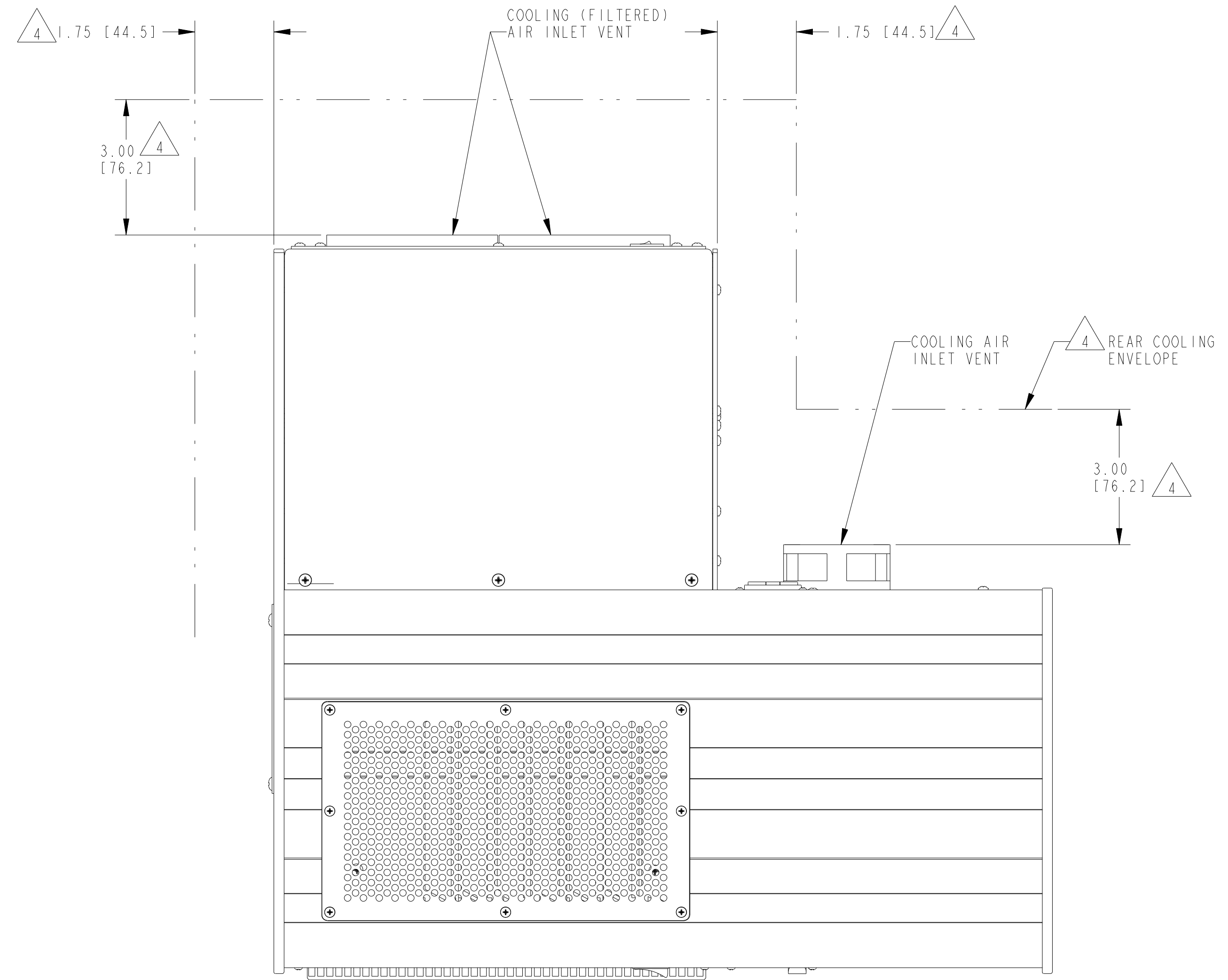
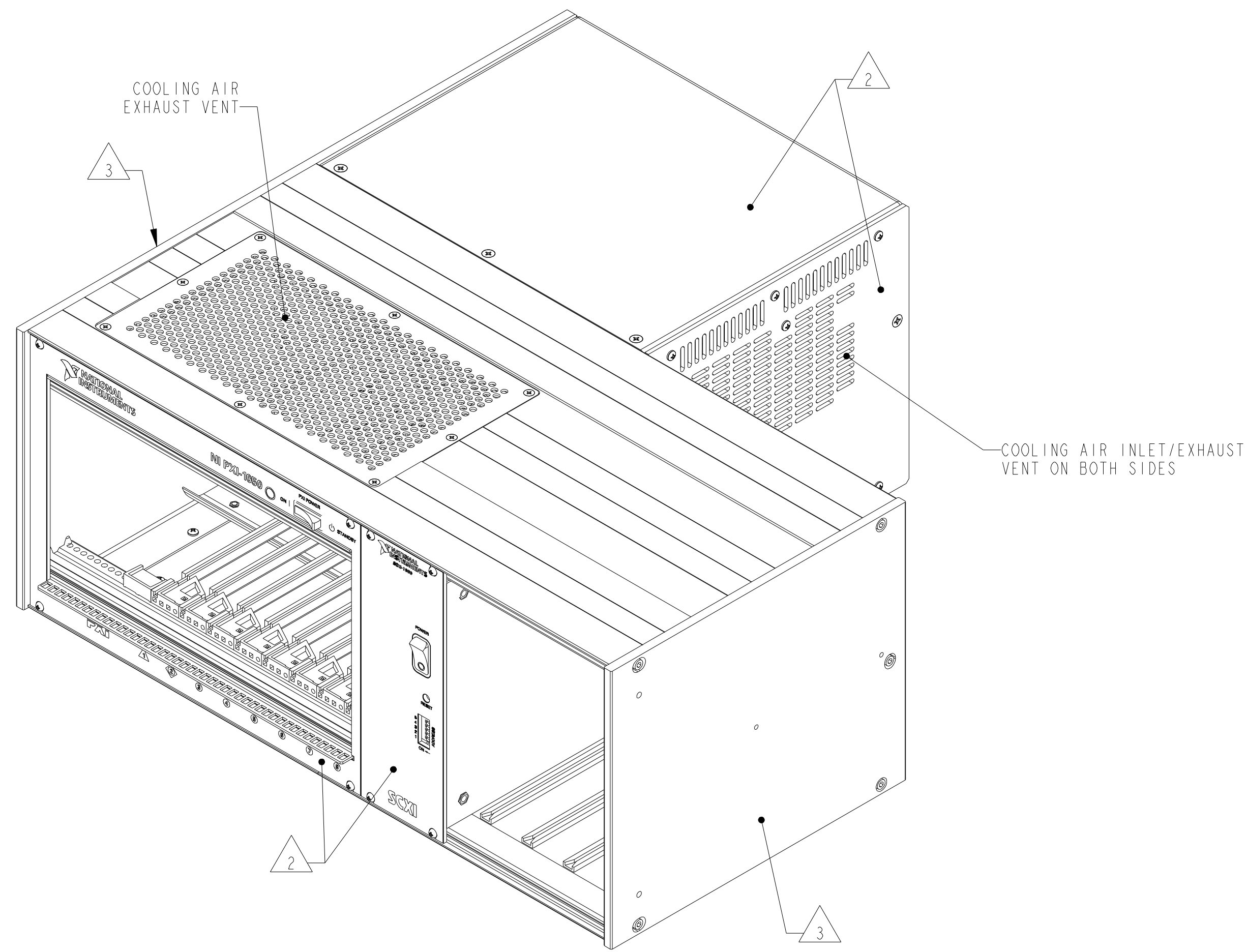

COOLING INFORMATION

SIZE	CODE	IDENT NO	MM/DD/YYYY
D	7U296		11/06/2007
SCALE: 1/2		SHEET 2 OF 2	