

High-Speed Counter Modules for Compact FieldPoint and FieldPoint

NI [c]FP-CTR-500, NI [c]FP-CTR-502

NEW

- 8 inputs
- 5 to 30 VDC inputs
- 16-bit counter registers
- 50 kHz, maximum
- Gate inputs and digital outputs
- Cascadable counters for higher counts
- 2,300 V_{rms} bank isolation for transient overvoltage protection
- Hot swappable with autoconfiguration
- -40 to 70 °C operating range



Module	Counter Inputs	Input Ranges	Inputs Type	Counter Resolution	Gate Inputs	Configurable Outputs	Internal Reference Clock for Frequency Measurements	Maximum Input Frequency
[c]FP-CTR-500	8	10 to 30 VDC	Sourcing	16 bit, cascadable to 128 bit	4	4	1 and 32 kHz	50 kHz
[c]FP-CTR-502	8	5 to 30 VDC	Sinking	16 bit, cascadable to 128 bit	4	4	1 and 32 kHz	50 kHz

Overview

The National Instruments [c]FP-CTR-50x devices are versatile, high-speed digital counter input modules for Compact FieldPoint and FieldPoint that can be used to count digital signals ranging from 5 to 30 VDC and to measure frequency. These modules are fast enough to handle input signals up to 50 kHz for high-speed applications, and flexible enough to measure frequency using the internal frequency reference or the external gate inputs. These powerful and versatile counter modules feature configurable lowpass filters to eliminate high-frequency noise and cascadable counter channels that can be used to create counters up to 128 bits wide that will store trillions of counts. For discrete control applications such as packaging, the digital output channels can be configured to automatically energize external devices.

All the modules include onboard diagnostics to ensure trouble-free installation and maintenance.

Counter Modules

The CTR-500 and CTR-502 counter modules include eight 16-bit, 50 kHz counters with dedicated clock inputs. For higher resolution counting, you can combine counter channels to provide cascaded counters of up to 128 bits. In addition, for each counter, you can set a terminal count at which the counter automatically rolls over or resets. For frequency measurement, you can configure each channel to use any one of the four gate inputs provided. In this mode, you can enable counting only when the state of the specified gate input is

logic high. By sending the digital pulse train to the gate input and using the internal reference clock of 1 or 32 kHz, you can measure the frequency of the incoming pulse train. Because you can read the state of the gate input, you can also use the four gate inputs as general-purpose digital input channels.

You can configure each of the four counter outputs to either pulse or toggle states when you reach the terminal count for a counter input. This is useful when you need to energize external equipment upon reaching a particular count for applications like packaging. You can also use each of the outputs as general-purpose digital outputs.

The CTR-500 modules work with 10 to 30 VDC sourcing devices and provides sourcing outputs. A sourcing device is one that connects and disconnect a voltage to the counter module. CTR-500 modules use a common ground plane for all the digital input channels.

The CTR-502 modules work with 5 to 30 VDC sinking devices and provides sinking outputs. A sinking device is one that connects and disconnects a common to the counter module. CTR-502 modules use a common ground plane for all the digital input channels.

All the channels on the digital input modules feature LEDs that indicate the input state of each channel.

Isolation

CTR-50x modules feature optical bank isolation with 2,300 V_{rms} of breakdown isolation. These Compact FieldPoint and FieldPoint modules do not have channel-to-channel isolation.

High-Speed Counter Modules for Compact FieldPoint and FieldPoint

Field I/O Connections

Compact FieldPoint and FieldPoint modules include a built-in power distribution bus that provides multiple power connections on the module. A field-wired power supply connected to the voltage (V) and common (C) terminals is internally connected to a power distribution bus that provides additional breakout terminals for voltage supply (V_{SUP}) and common (COM). These terminals provide a convenient way to distribute power to field devices that require external power.

The CTR-500 and CTR-502 have:

- 8 high speed digital counter input terminals (V_{IN})
- 4 digital gate input terminals (V_{IN})
- 4 digital output terminals (V_{OUT})
- 8 common terminals (C_{OM})
- 8 power connections to power field devices (V_{SUP})

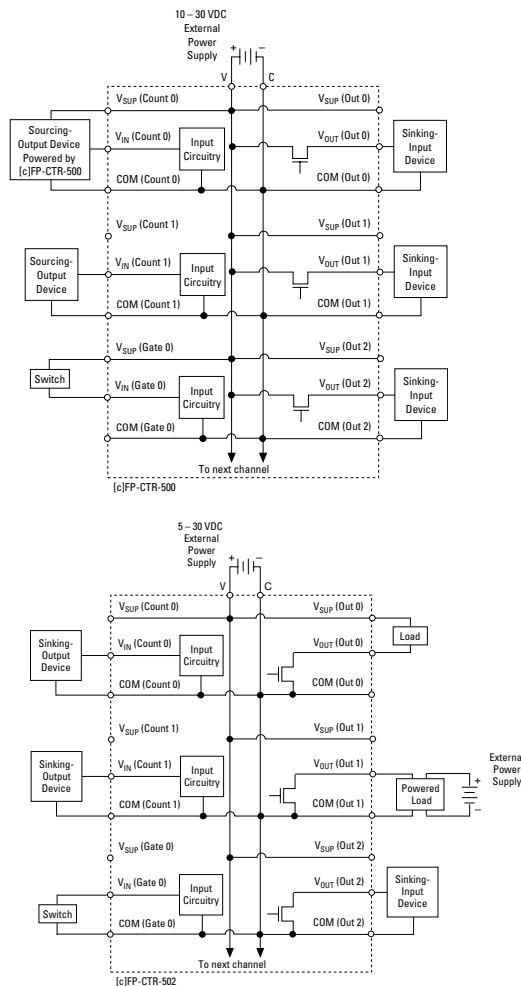

Figure 1. Wiring Schematic for CTR Modules

Ordering Information

Compact FieldPoint

NI cFP-CTR-500.....	777318-500
NI cFP-CTR-502.....	777318-502

Recommended Compact FieldPoint System Products

NI cFP-2020	777317-2020
NI cFP-BP-4	778617-04
NI cFP-CB-1	778618-01
NI PS-5 power supply	778805-90
NI Developer Suite Professional Control Edition.....	777906-03

FieldPoint

NI FP-CTR-500	777518-500
NI FP-CTR-502	777518-502

Recommended FieldPoint System Products

NI FP-1601	777792-01
NI FP-TB-1	777519-01
NI PS-4 power supply	778586-90
NI Developer Suite Standard Control Edition	777905-03

BUY ONLINE!

Visit ni.com/info and enter *cfpctr500*, *cfpctr502*, *fpctr500*, and/or *cfpctr502*.

High-Speed Counter Modules for Compact FieldPoint and FieldPoint

Specifications

Typical for -40 to 70 °C unless otherwise noted.

Input Characteristics

Input channels	12 (8 count, 4 gate)
Input type	
[c]FP-CTR-500	10-30 VDC, sinking
[c]FP-CTR-502	5-30 VDC, sourcing
Maximum input voltage	30 VDC
Input threshold level	
[c]FP-CTR-500	8 V typ 6 V min 10 V max
[c]FP-CTR-502	$V_{SUP} - 2.5$ V typ $V_{SUP} - 3.0$ V min $V_{SUP} - 2.0$ V max (V_{SUP} is the external supply voltage)
Input current limiting	
[c]FP-CTR-500	5 mA
[c]FP-CTR-502	6 mA
Input bandwidth	
Count inputs	50 kHz or software-enabled 200 kHz lowpass filter
Gate inputs	50 kHz
Maximum off-state leakage current for external devices	
[c]FP-CTR-500	0.2 mA
[c]FP-CTR-502	0.3 mA

Output Characteristics

Output channels	4
Output type	
[c]FP-CTR-500	10-30 VDC sourcing, compatible with most 12 and 24 VDC devices
[c]FP-CTR-502	5-30 VDC sinking, compatible with TTL and other 5, 12, and 24 VDC devices
Supply voltage	
[c]FP-CTR-500	10-30 VDC, user-provided
[c]FP-CTR-502	5-30 VDC, user-provided
Maximum output current	
FP-CTR-500/502	1 A per channel
cFP-CTR-500/502	1 A per channel at -40 to 50 °C; 0.75 A per channel at 50 to 60 °C
Maximum output current on all channels	4 A
Output impedance	
[c]FP-CTR-500	0.3 Ω
[c]FP-CTR-502	0.12 Ω
Output bandwidth	16 kHz for a current flow ≥ 3.2 mA
Maximum off-state leakage current	25 μ A

Power Requirement

Power from network module	800 mW
---------------------------	--------

Physical Characteristics

LED indicators	
POWER (green)	Power on and self-test passed
READY (green)	Module configured and ready
Count inputs <0..7> (green)	On/off state of counter input
Gate inputs <0..3> (green)	On/off state of gate input
Outputs <0..3> (green)	On/off state of output
Dimensions (including terminal base)	10.7 by 10.9 by 9.1 cm (4.2 by 4.3 by 3.6 in.)
Weight	
FP-CTR-500/502	130 g (4.6 oz)
cFP-CTR-500/502	100 g (3.5 oz)

Isolation Voltage

Maximum isolation voltage	250 V_{rms} , Installation Category II
Channel-to-channel isolation	No isolation between channels
Transient overvoltage	2,300 V_{rms}

Environment

Operating temperature	
FP-CTR-500/502	-40 to 70 °C
cFP-CTR-500/502	-40 to 60 °C
Storage temperature	-55 to 85 °C
Relative humidity	10 to 90%, noncondensing

Shock and Vibration

These specifications apply only to Compact FieldPoint. NI recommends Compact FieldPoint if your application is subject to shock and vibration.

Operating vibration, random	
(IEC 60068-2-64)	10 to 500 Hz, 5 g_{rms}
Operating vibration, sinusoidal	
(IEC 60068-2-6)	10 to 500 Hz, 5 g
Operating shock	
(IEC 60068-2-27)	50 g, 3 ms half sine, 18 shocks at 6 orientations; 30 g, 11 ms half sine, 18 shocks at 6 orientations

Safety

This product is designed to meet the requirements of the following standards of safety for electrical equipment for measurement, control, and laboratory use:

- IEC 61010-1, EN 61010-1
- UL 3121-1, UL 61010C-1
- CAN/CSA C22.2 No. 1010.1

For UL, hazardous location, and other safety certifications, refer to the product label or to ni.com

Electromagnetic Compatibility

CE, C-Tick, and FCC Part 15 (Class A) Compliant

Emissions	EN 55011 Class A at 10 m FCC Part 15A above 1 GHz
Immunity	EN 61326:1997 + A2:2001, Table 1

For EMC compliance, operate this device with shielded cabling.

CE Compliance

This product meets the essential requirements of applicable European Directives, as amended for CE Marking, as follows:

Low-Voltage Directive (safety)	73/23/EEC
Electromagnetic Compatibility Directive (EMC)	89/336/EEC

Refer to the Declaration of Conformity (DoC) for this product for any additional regulatory compliance information. To obtain the DoC for this product, visit ni.com/hardref.nsl/ and search by model number or product line.

Global Services and Support

NI has the services and support to meet your needs around the globe and through the application life cycle – from planning and development through deployment and ongoing maintenance – and tailored for customer requirements in research, design, validation, and manufacturing. We have direct operations in more than 37 countries and distributors in another 12 locations. Our local sales and support representatives are degreed engineers, ready to partner with you to find solutions that best fit your needs.

Local Sales and Technical Support

In offices around the globe, our staff is local to the country so that you have access to field engineers who speak your language and are available to consult on your unique needs. We also have a worldwide support organization staffed with Applications Engineers trained to quickly provide superior technical assistance. Use our online Request Support interface (ni.com/support) to define your question, then speak to or e-mail an Applications Engineer, or access more than 14,000 worldwide measurement and automation professionals within NI Developer Exchange Discussion Forums. ni.com/support also provides immediate answers to your questions through self-help troubleshooting, product reference, and application development resources. For advanced technical support and software maintenance services, sign up for Premier Support, a program that provides expanded hours of support availability and expedited phone/e-mail response time (typically four business hours).

Training and Certification

NI recognizes that both initial instruction and ongoing education contribute to your success. NI provides a variety of training alternatives, from self-paced tutorials and interactive CDs, to worldwide hands-on courses taught by experienced instructors – all designed so that you can choose how to learn about our products. Further, NI offers certifications acknowledging individual expertise in working with NI products and technologies. Visit ni.com/training for more information.

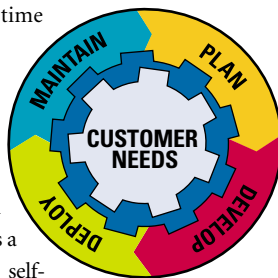

Professional Services

Our Professional Services team consists of National Instruments Applications Engineers, NI Consulting Services, and the worldwide National Instruments Alliance Partner Program (a network of 600 independent consultants and integrators). Our Professional Services team can offer services ranging from basic start-up assistance and collaborative development with your engineers, to turnkey system integration and maintenance of your system.



In addition to our NI Alliance Partners, we have developed global relationships with many industry partners that range from computer software and hardware companies, such as Microsoft, Dell, Siemens, and Tektronix. By collaborating with these companies, you receive a complete spectrum of solutions – from components to turnkey systems. Find the Alliance Partner directory at ni.com/alliance

Product Services

NI hardware products are warranted against defects in workmanship and material for one year from the date of shipment. To help you meet project life-cycle requirements, NI offers extended warranties for an additional charge. NI provides complete repair services for our products. Express repair and advanced replacement services are also available. Or, order your software and hardware installed in PXI and PXI/SCXI™ systems with NI Factory Installation Services.

Ordering Made Easy

Visit ni.com/products to browse product specifications, make comparisons, or access technical representatives via online chat or telephone. Worldwide customers can use a purchase order or credit card to buy in local currency and receive direct shipments from local NI offices. Our North American Customer Service Representatives are available Monday through Friday between 7 a.m. and 7 p.m. Central Time. Outside North America, please contact the NI office in your country.

Order Status and Service Requests

National Instruments brings you real-time status on current orders at ni.com/status. Similarly, find out the status of open technical support incidents or hardware repair requests at ni.com/support/servicereq



ni.com • (800) 433-3488

National Instruments • Tel: (512) 683-0100 • Fax: (512) 683-9300 • info@ni.com