

# 8-Slot PXI Express Chassis for PXI and PXI Express Modules

## NI PXIe-1082 **NEW!**

- Accepts 3U PXI Express and CompactPCI Express modules in every slot and PXI and CompactPCI modules in designated slots
  - 1 PXI Express system slot
  - 7 peripheral slots
    - 7 PXI Express compatible
    - 4 PXI compatible
    - 1 PXI Express system timing compatible
  - Up to 1 GB/s per-slot dedicated bandwidth (x4 PCI Express), 4 GB/s total system bandwidth
  - Low-jitter 100 MHz reference clock for PXI Express slots with 25 ppm stability
  - Low-jitter internal 10 MHz reference clock for PXI slots with 25 ppm stability
  - Variable speed fan controller optimizes cooling and acoustic emissions
  - Quiet operation for 0 to 30 °C at 43.6 dBA
  - Remote power-inhibit control
- High Reliability**
- 0 to 55 °C extended operating temperature range
  - 507 W from 0 to 55 °C without derating
  - NI PXI System Monitor API for power supply, temperature, and fan monitoring
  - HALT tested for increased reliability
  - Field-replaceable power supply and fan shuttle
- Multichassis Support**
- Numerous synchronization options: CLK10 sharing, GPS, IEEE 1588, IRIG-B, and so on
  - PXI Express system timing slot for tight synchronization across chassis
  - Switchless CLK10 routing
- Optional Accessories**
- Portable LCD monitor and keyboard accessory
  - Front and rear rack-mount kits
  - System assurance program



Slot Type	PXI Express System Controller	PXI Express Peripheral	Hybrid (PXI)
Bus Signaling	PCI Express (4 x4 links) and PCI (32/33)	PCI Express (x4)	PCI Express (x4) and PCI (32/33)
Bandwidth	4 GB/s dedicated for PXI Express and 132 MB/s shared for PXI	Up to 1 GB/s dedicated <sup>1</sup>	132 MB/s shared (PXI) or up to 1 GB/s dedicated <sup>1</sup> (PXI Express)
Number of Slots	1	3 <sup>2</sup>	4

<sup>1</sup>Each slot can have up to 1 GB/s dedicated bandwidth; however, if more than one slot connected to the same switch is used, 1 GB/s is shared among those slots.

<sup>2</sup>Includes one system timing slot.

Table 1. Bus Bandwidth and Signaling for the NI PXIe-1082 Slot Types

## Overview

The NI PXIe-1082 eight-slot chassis features a high-bandwidth backplane with PXI Express capability in every slot to meet a wide variety of high-performance test and measurement and control application needs. It is ideal for high-speed measurements, data streaming, and high-channel-density system solutions. Its compact form factor and optional portable LCD monitor and keyboard accessory make the NI PXIe-1082 ideal for portable applications. The chassis provides the full power of 507 W across the entire 0 to 55 °C extended

temperature range, a feature National Instruments offers on all NI high-performance chassis.

The NI PXIe-1082 is compatible with both PXI Express and CompactPCI Express modules. In addition, this chassis features four hybrid slots, which provide the added compatibility with standard PXI and CompactPCI modules.

The chassis also incorporates all of the timing and synchronization features defined by the latest PXI specification, including a built-in 10 MHz reference clock, PXI trigger bus, and PXI star trigger as well as a built-in 100 MHz reference clock, SYNC 100, and PXI differential star triggers for PXI Express modules.

## Slot Types Accept PXI and PXI Express Modules

This chassis enables high-bandwidth systems and provides the flexibility you need to work with both PXI and PXI Express modules. There are a total of three PXI Express slots and four PXI hybrid-compatible slots. PXI hybrid-compatible slots can accept either a PXI Express module or a standard PXI module.

The PXI Express system slot offers four x4 PCI Express links (1 GB/s single direction per link): one x4 link is connected directly to slot 2 and the other three x4 links are connected to three switches. Each switch provides a x4 PCI Express link to two peripheral slots. Each slot is capable of 1 GB/s per-direction dedicated bandwidth; however, if you use another slot connected to the same

## 8-Slot PXI Express Chassis for PXI and PXI Express Modules

switch, the slots share the 1 GB/s total bandwidth to the switch. The total system bandwidth is also dependent on the PXI Express controller selected.

There is one x1 PCI Express link to a PCI Express-to-PCI translation bridge on the backplane. The four PXI Express hybrid slots deliver connectivity to either a x4 PCI Express link or to the 32-bit, 33 MHz PCI bus on the backplane. The PXI Express system timing slot accepts a PXI Express module or a PXI Express system timing controller for advanced timing and synchronization.

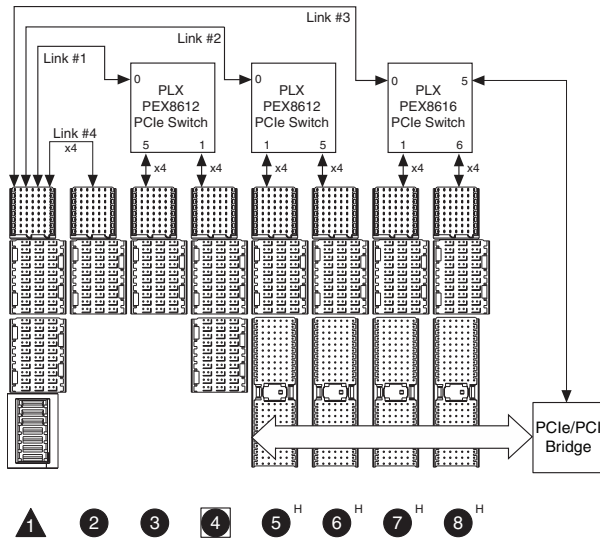

Figure 1. NI PXIe-1082 Backplane

### Optimized Cooling and Acoustic Emissions

The NI PXIe-1082 chassis integrates two pulse-width modulation (PWM) system fans to provide filtered, forced-air cooling that exceeds the cooling demands of PXI Express and CompactPCI Express as well as PXI and CompactPCI modules. The NI PXIe-1082 offers a HIGH fan setting to maximize cooling and an AUTO fan setting to minimize acoustic emissions when operating the chassis in ambient environments less than 55 °C. The chassis monitors air intake temperature and adjusts fan speed accordingly while the AUTO setting is selected. With this technology, the NI PXIe-1082 achieves acoustic noise levels as low as 43.6 dBA (sound pressure level measured at operator position according to ISO 7779).

### PXI Timing and Synchronization

For PXI modules, the NI PXIe-1082 backplane is fully compliant with PXI timing and synchronization standards. The chassis includes a 10 MHz reference clock with an accuracy of  $\pm 25$  parts per million (ppm), less than 5 ps jitter, and a maximum slot-to-slot skew of 300 ps. For triggering and handshaking needs, the NI PXIe-1082 offers the PXI trigger bus and PXI star trigger.

For PXI Express modules, in addition to PXI timing and synchronization features, the NI PXIe-1082 backplane offers a differential 100 MHz reference clock with an accuracy of  $\pm 25$  ppm, less than 3 ps jitter, and a maximum slot-to-

slot skew of 100 ps. The chassis also provides a differential star trigger to the PXI Express slots to deliver less than 200 ps intermodule skew. With the SYNC 100, a peripheral module installed in the NI PXIe-1082 can generate its own CLK10 signal, deriving it from the 100 MHz reference clock.

### Software System Configuration

The NI PXIe-1082 chassis system software is configured with NI Measurement & Automation Explorer (MAX). NI MAX allows for easy configuration without the need to use manually installed configuration files. MAX automatically creates the pxisys.ini file that defines the layout and parameters of your PXI system including chassis, controller, and plug-in modules.

### Replaceable Power Supply Shuttle

This chassis includes a field-removable high-performance universal AC power supply with built-in overcurrent protection. An isolated 12 VDC line provides power to the cooling fans, significantly reducing electrical noise on the chassis backplane. The NI PXIe-1082 incorporates the power supply and fans into a single modular unit that you can remove quickly for service, resulting in a mean time to repair (MTTR) of less than five minutes.

### External 10 MHz Reference Clock I/O Connectors

An NI PXIe-1082 chassis includes IN/OUT BNC connectors for the 10 MHz reference clock on the rear of the chassis. When the backplane detects a 10 MHz signal on the IN connector, it phase locks to the external clock. The OUT connector provides a buffered, non-TTL version of the 10 MHz reference clock.

The 10 MHz clock may also be driven by an optional system timing controller populated in slot 4. These system timing controllers provide a higher-stability clock source such as an oven-controlled crystal oscillator (OCXO) and the ability to drive the PXI star and PXI Express differential star triggers as well as import or export the various trigger lines on the backplane.

### Remote Power Inhibit and Monitoring

The NI PXIe-1082 chassis features remote power inhibit and monitoring through a DB-9 connector on the rear of the chassis. Use this connector to switch off power or monitor the power remotely in the chassis.

### Power Supply, Temperature, and Fan Monitoring

This chassis continuously monitors power supply voltages, air intake temperature, and fan speeds to ensure safe system operation in the event of an unexpected system event. It provides feedback to the user via a bicolor LED in the power switch on the front of the chassis, and the chassis makes necessary adjustments to continue operation such as increase fan speeds if the temperature rises. You can also monitor the status of the NI PXIe-1082 with the included NI PXI System Monitor API.

# 8-Slot PXI Express Chassis for PXI and PXI Express Modules

## NI PXIe-1082 Accessories

The NI PXIe-1082 has several optional accessories for complete system integration and optimized chassis functionality. An optional, attachable, and portable LCD monitor and keyboard accessory and a rugged portable carrying case provide effective portable solutions. Front and rear rack-mount kits are available for 19 in. rack-mounted systems. You can easily replace spare power supplies with little system downtime because of the modular nature of the NI PXIe-1082 power supply and fan shuttle. You can use slot blockers to improve the overall cooling performance of the chassis.

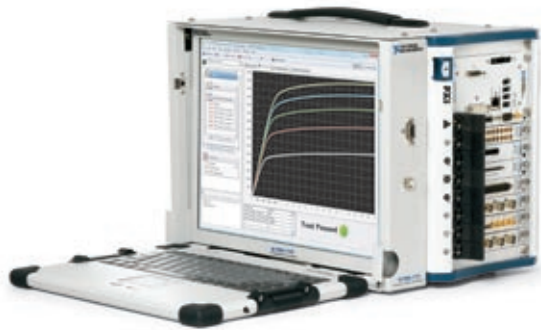

Figure 2. NI PMA-1115 Portable Touch Screen LCD Monitor, Keyboard, and Touchpad Accessory Attached to National Instruments Eight-Slot Chassis



Figure 3. NI PXI Carrying Case Accessory

## PXI System Assurance Program

With an NI system assurance program, you receive complete system-level assembly and functional testing of the PXI chassis, controller, and all peripheral devices, as well as installation of all device drivers and software programs (such as NI LabVIEW). For online configuration of a complete PXI system, including information about NI system assurance programs, visit the PXI Advisor at [ni.com/pxiadvisor](http://ni.com/pxiadvisor).

## Ordering Information

For the best PXI system ordering experience, use the intuitive NI PXI Advisor online to select all of the components for your system. Visit [ni.com/pxiadvisor](http://ni.com/pxiadvisor).

### Step 1. Select your chassis.

NI PXIe-1082 ..... 780321-01

### Step 2. Select one or more power cords.

U.S. 120 VAC (125 V/10 A)..... 736000-01  
Japan 100 VAC (125 V/10 A) ..... 763634-01  
United Kingdom 240 VAC..... 763064-01  
Swiss 220 VAC..... 763065-01  
Australian 240 VAC..... 763066-01  
Universal Euro 240 VAC ..... 763067-01  
North American 240 VAC..... 763068-01

### Step 3. Select additional accessories.

To see a complete list of accessories for your PXI system, visit [ni.com/pxiadvisor](http://ni.com/pxiadvisor).

NI PMA-1115 portable LCD monitor and keyboard accessory ..... 780215-01  
NI PXI carrying case ..... 780398-01  
Front rack-mount kit (for 19 in. rack)..... 778643-01  
Rear rack-mount kit (for 19 in. rack)..... 778643-02  
NI PXIe-1082<sup>1</sup> spare power shuttle..... 780322-01  
EMC filler panels (6 single-slot)..... 778700-01  
Filler panel kit (7 single-slot, 1 double-slot,  
and 2 quadruple-slot)<sup>2</sup>..... 778646-01

NI PXI slot blocker, set of 5<sup>3</sup>..... 199198-01

<sup>1</sup>NI PXIe-1082 power shuttles are not compatible with previous generations of NI 8-slot chassis.

<sup>2</sup>Every NI PXIe-1082 comes with a filler panel kit.

<sup>3</sup>Slot blockers are optional for improved thermal performance of your NI PXIe-1082. When you select the NI Standard System Assurance Program, unpopulated slots are populated with slot blockers automatically.

### Step 4. Select system setup and installation services.

If you are ordering this chassis as part of a system, select an NI system assurance program to have your hardware/software installed and receive your new PXI system ready to use right out of the box. Please use the PXI Advisor at [ni.com/pxiadvisor](http://ni.com/pxiadvisor) to properly select your PXI system.

## BUY NOW

For complete product specifications, pricing, and accessory information, call 800 813 3693 (U.S.) or go to [ni.com/pxi](http://ni.com/pxi).

# 8-Slot PXI Express Chassis for PXI and PXI Express Modules

## Specifications

This appendix contains specifications for the NI PXIe-1082 chassis. For complete specifications, refer to the *NI PXIe-1082 User Manual* at [ni.com/manuals](http://ni.com/manuals).

Specifications are subject to change without notice.

## Electrical

### AC input

Input voltage rating.....	100 to 240 VAC (UL listed)
Operating voltage range <sup>1</sup> .....	90 to 264 VAC (UL listed)
Input frequency .....	50/60 Hz
Input current rating .....	8 - 4 A maximum
Overcurrent protection .....	10 A circuit breaker

### Line regulation

3.3 V .....	<±0.2%
5 V .....	<±0.1%
±12 V .....	<±0.1%

Efficiency ..... 70% typical

<sup>1</sup>The operating range is guaranteed by design.

Power disconnect..... The AC power cable provides main power disconnect. The front-panel power switch causes the internal chassis power supply to provide DC power to the CompactPCI/PXI Express backplane. You also can use the rear-panel D-Sub 9-pin connector and power mode switch to control the internal chassis power supply.

## DC Output

DC current capacity (IMP)

Voltage	Maximum Current (A)
+3.3 V	32
+5 V	34
+12 V	32
-12 V	2.0
5 V <sub>AUX</sub>	2.0

**Note:** Maximum total power is 507 W.

The maximum power dissipated in the system slot should not exceed 140 W.

The maximum power dissipated in a peripheral slot should not exceed 38 W.

## Backplane pin current capacity

Slot	+5 V	V (I/O)	+3.3 V	+12 V	-12 V	5 V <sub>AUX</sub>
System controller slot	9 A	0 A	9 A	11 A	0 A	1 A
System timing slot	0 A	0 A	3 A	2 A	0 A	1 A
Hybrid peripheral slot with PXI peripheral (PXI-1)	6 A	5 A	6 A	1 A	1 A	0 A
Hybrid peripheral slot with PXI Express peripheral (PXI-5)	0 A	0 A	3 A	2 A	0 A	1 A
PXI Express peripheral (PXI-5)	6 A	11 A	6 A	1 A	1 A	0 A

## Load regulation

Voltage (V)	Load Regulation (%)
+3.3	<5
+12	<5
+5	<5
-12	<5

## Maximum ripple and noise (20 MHz bandwidth)

Voltage (V)	Maximum Ripple and Noise (mV <sub>pp</sub> )
+3.3	50
+12	50
+5	50
-12	50

Overcurrent protection ..... All outputs protected from short circuit and overload with automatic recovery

Overvoltage protection  
3.3 and 5 V..... Clamped at 20 to 30% above nominal output voltage

Power supply shuttle MTTR..... Replacement in less than 5 minutes

## Chassis Cooling

### Module cooling system

NI PXIe-1082 ..... Forced air circulation (positive pressurization) through two 110 cfm fans with HIGH/AUTO speed selector

Slot airflow direction..... Bottom of module to top of module

Module cooling intake ..... Bottom rear of chassis

Module cooling exhaust..... Along both sides and top of chassis

Power supply cooling system..... Forced air circulation through two integrated fans

Power supply cooling intake ..... Right side of chassis

Power supply cooling exhaust ..... Left side of chassis

## 8-Slot PXI Express Chassis for PXI and PXI Express Modules

### Environmental

Maximum altitude.....	2,000 m (800 mbar) (at 25 °C ambient)
Pollution degree.....	2
For indoor use only.	

### Operating Environment

Ambient temperature range.....	0 to 55 °C (tested in accordance with IEC-60068-2-1 and IEC-60068-2-2; meets MIL-PRF-28800F Class 3 low temperature limit and MIL-PRF-28800F Class 2 high temperature limit)
Relative humidity range.....	10 to 90%, noncondensing (tested in accordance with IEC-60068-2-56)

### Storage Environment

Ambient temperature range.....	-40 to 71 °C (tested in accordance with IEC-60068-2-1 and IEC-60068-2-2; meets MIL-PRF-28800F Class 3 limits)
Relative humidity range.....	5 to 95%, noncondensing (tested in accordance with IEC-60068-2-56)

### Shock and Vibration

Operational shock.....	30 g peak, half-sine, 11 ms pulse (tested in accordance with IEC-60068-2-27; meets MIL-PRF-28800F Class 2 limits)
------------------------	--

### Random Vibration

Operating.....	5 to 500 Hz, 0.3 g <sub>rms</sub>
----------------	-----------------------------------

### Acoustic Emissions

#### Sound Pressure Level (at Operator Position)

(tested in accordance with ISO 7779; meets MIL-PRF-28800F requirements)

Auto fan (up to ~30 °C ambient).....	43.6 dBA
High fan.....	62.0 dBA

#### Sound Power

Auto fan (up to ~30 °C ambient).....	52.8 dBA
High fan.....	72.0 dBA

### Backplane

Size.....	3U; one system slot (with three system expansion slots) and 7 peripheral slots. Compliant with IEEE 1101.10 mechanical packaging. PXI Express Specification compliant. Accepts both PXI Express and CompactPCI (PICMG 2.0 R 3.0) 3U modules.
Backplane bare-board material.....	UL 94 V-0 recognized
Backplane connectors.....	Conforms to IEC 917 and IEC 1076-4-101, and are UL 94 V-0 rated

### System Synchronization Clocks (PXI\_CLK10, PXIe\_CLK100, PXIe\_SYNC100)

#### 10 MHz System Reference Clock: PXI\_CLK10

Maximum slot-to-slot skew.....	300 ps
Accuracy.....	±25 ppm maximum (guaranteed over the operating temperature range)
Maximum jitter.....	5 ps RMS phase-jitter (10 Hz to 1 MHz range)
Duty-factor.....	45 to 55%
Unloaded signal swing.....	3.3 V ±0.3 V

**Note:** For other specifications, refer to the PXI-1 Hardware Specification.

#### 100 MHz System Reference Clock: PXIe\_CLK100 and PXIe\_SYNC100

Maximum slot-to-slot skew.....	100 ps
Accuracy.....	±25 ppm max (guaranteed over the operating temperature range)
Maximum jitter.....	3 ps RMS phase-jitter (10 Hz to 12 kHz range); 2 ps RMS phase-jitter (12 kHz to 20 MHz range)
Duty-factor for PXIe_CLK100.....	45 to 55%

Absolute differential voltage

(when terminated with a 50 Ω load

to 1.30 V or Thévenin equivalent)..... 400 to 1000 mV

**Note:** For other specifications, refer to the PXI-5 PXI Express Hardware Specification.

## 8-Slot PXI Express Chassis for PXI and PXI Express Modules

### External 10 MHz Reference Out (BNC on rear panel of chassis)

Accuracy.....	±25 ppm max (guaranteed over the operating temperature range)
Maximum jitter.....	5 ps RMS phase-jitter (10 Hz to 1 MHz range)
Output amplitude .....	1 V <sub>PP</sub> ±20% square-wave into 50 Ω, 2 V <sub>pp</sub> unloaded
Output impedance.....	50 Ω ±5 Ω

### External Clock Source

Frequency.....	10 MHz ±100 ppm
Input amplitude	
Rear panel BNC.....	200 mV <sub>pp</sub> to 5 V <sub>pp</sub> square-wave or sine-wave system timing slot
10 MHz rear panel BNC input impedance.....	50 Ω ±5 Ω
System timing slot PXI_CLK10_IN.....	5 or 3.3 V TTL signal
Maximum jitter introduced by backplane.....	1 ps RMS phase-jitter (10 Hz to 1 MHz range)

### PXIe\_SYNC\_CTRL

V <sub>IH</sub> .....	2.0 to 5.5 V
V <sub>IL</sub> .....	0 to 0.8 V

### PXI Star Trigger

Maximum slot-to-slot skew .....	250 ps
Backplane characteristic impedance....	65 Ω ±10%

### PXI Differential Star Triggers (PXIe-DSTARA, PXIe-DSTARB, PXIe-DSTARC)

Maximum slot-to-slot skew .....	150 ps
Maximum differential skew.....	25 ps
Backplane differential impedance .....	100 Ω ±10%

### Mechanical

Overall dimensions

Standard chassis

Height.....	6.97 in. (177.1 mm)
Width.....	10.68 in. (271.4 mm)
Depth.....	15.61 in. (396.5 mm)

**Note:** 0.57 in. (14.5 mm) is added to height when feet are installed. When tilted with front feet extended on table top, height is increased approximately 2.08 in. (52.8 mm) in front and 0.583 in. (14.8 mm) in rear.

Weight.....	8.8 kg (19.4 lb)
Chassis materials.....	Sheet Aluminum (5052-H32, 3003-H14, and 6061-T6), Extruded Aluminum (6060-T6), and Cold Rolled Steel, PC-ABS, Santoprene, Nylon
Finish .....	Conductive Clear Iridite on Aluminum Electroplated Nickel on Cold Rolled Steel Polyurethane Enamel

### Safety

This product is designed to meet the requirements of the following standards of safety for electrical equipment for measurement, control, and laboratory use:

- EN 61010-1, IEC 61010-1
- UL 61010-1, CSA 61010-1

**Note:** For UL and other safety certifications, refer to the product label or visit [ni.com/certification](http://ni.com/certification), search by model number or product line, and click the appropriate link in the Certification column.

### Electromagnetic Compatibility

This product is designed to meet the requirements of the following standards of EMC for electrical equipment for measurement, control, and laboratory use:

- EN 61326 (IEC 61326): Class A emissions, basic immunity
- EN 55011 (CISPR 11): Group 1, Class A emissions
- AS/NZS CISPR 11: Group 1, Class A emissions
- FCC 47 CFR Part 15B: Class A emissions
- ICES-001: Class A emissions

**Note:** For EMC compliance, operate this device according to printed documentation.

### CE Compliance

This product meets the essential requirements of applicable European Directives, as amended for CE marking, as follows:

- 2006/95/EC; Low-Voltage Directive (safety)
- 2004/108/EC; Electromagnetic Compatibility Directive (EMC)

**Note:** Refer to the Declaration of Conformity (DoC) for this product for any additional regulatory compliance information. To obtain the DoC for this product, visit [ni.com/certification](http://ni.com/certification), search by model number or product line, and click the appropriate link in the Certification column.

### Waste Electrical and Electronic Equipment (WEEE)

**EU Customers:** At the end of their life cycle, all products must be sent to a WEEE recycling center. For more information about WEEE recycling centers and National Instruments WEEE initiatives, visit [ni.com/environment/weee.htm](http://ni.com/environment/weee.htm).

# NI Services and Support



NI has the services and support to meet your needs around the globe and through the application life cycle – from planning and development through deployment and ongoing maintenance. We offer services and service levels to meet customer requirements in research, design, validation, and manufacturing.

Visit [ni.com/services](http://ni.com/services).

## Training and Certification

NI training is the fastest, most certain route to productivity with our products. NI training can shorten your learning curve, save development time, and reduce maintenance costs over the application life cycle. We schedule instructor-led courses in cities worldwide, or we can hold a course at your facility. We also offer a professional certification program that identifies individuals who have high levels of skill and knowledge on using NI products.

Visit [ni.com/training](http://ni.com/training).

## Professional Services

Our NI Professional Services team is composed of NI applications and systems engineers and a worldwide National Instruments Alliance Partner program of more than 600 independent consultants and integrators. Services range from



start-up assistance to turnkey system integration. Visit [ni.com/alliance](http://ni.com/alliance).

## OEM Support

We offer design-in consulting and product integration assistance if you want to use our products for OEM applications. For information about special pricing and services for OEM customers, visit [ni.com/oem](http://ni.com/oem).



[ni.com](http://ni.com) ■ 800 813 3693

National Instruments ■ [info@ni.com](mailto:info@ni.com)

## Local Sales and Technical Support

In offices worldwide, our staff is local to the country, giving you access to engineers who speak your language. NI delivers industry-leading technical support through online knowledge bases, our applications engineers, and access to 14,000 measurement and automation professionals within NI Developer Exchange forums. Find immediate answers to your questions at [ni.com/support](http://ni.com/support).

We also offer service programs that provide automatic upgrades to your application development environment and higher levels of technical support. Visit [ni.com/ssp](http://ni.com/ssp).

## Hardware Services

### System Assurance Programs

NI system assurance programs are designed to make it even easier for you to own an NI system. These programs include configuration and deployment services for your NI PXI, CompactRIO, or Compact FieldPoint system. The NI Basic System Assurance Program provides a simple integration test and ensures that your system is delivered completely assembled in one box. When you configure your system with the NI Standard System Assurance Program, you can select from available NI system driver sets and application development environments to create customized, reorderable software configurations. Your system arrives fully assembled and tested in one box with your software preinstalled. When you order your system with the standard program, you also receive system-specific documentation including a bill of materials, an integration test report, a recommended maintenance plan, and frequently asked question documents. Finally, the standard program reduces the total cost of owning an NI system by providing three years of warranty coverage and calibration service. Use the online product advisors at [ni.com/advisor](http://ni.com/advisor) to find a system assurance program to meet your needs.

### Calibration Services

NI recognizes the need to maintain properly calibrated devices for high-accuracy measurements. We provide manual calibration procedures, services to recalibrate your products, and automated calibration software specifically designed for use by metrology laboratories. Visit [ni.com/calibration](http://ni.com/calibration).

### Repair and Extended Warranty

NI provides complete repair services for our products. Express repair and advance replacement services are also available. We offer extended warranties to help you meet project life-cycle requirements. Visit [ni.com/services](http://ni.com/services).