

8-Slot PXI Express Chassis for PXI and PXI Express Modules

NI PXIe-1062Q

- Accepts 3U PXI, PXI Express, CompactPCI, and CompactPCI Express modules

High Performance for Instrumentation Applications

- Up to 1 GB/s per-slot dedicated bandwidth [x4 PCI Express]
- 354 W available power for 0 to 55 °C
- 30 W per-slot cooling meets increased PXI Express cooling requirements
- Low-jitter internal 10 MHz reference clock for PXI slots with ± 25 ppm stability
- Low-jitter internal 100 MHz reference clock for PXI Express slots with ± 25 ppm stability
- Quiet operation for 0 to 30 °C at 43.6 dBA
- Variable speed fan controller optimizes cooling and acoustic emissions
- Remote power-inhibit control
- Complies with PXI and CompactPCI specifications

High Reliability

- 0 to 55 °C extended temperature range
- Power supply, temperature, and fan monitoring
- HALT-tested for increased reliability
- Field-replaceable power supply shuttle

Multichassis Synchronization

- PXI Express system timing slot for tight synchronization across chassis
- Rear CLK10 I/O connectors
- Switchless CLK10 routing

Optional Features

- Front and rear rack-mount kits
- Replacement power supply shuttle
- EMC filler panels
- Slot blockers for improved cooling performance
- Factory installation services

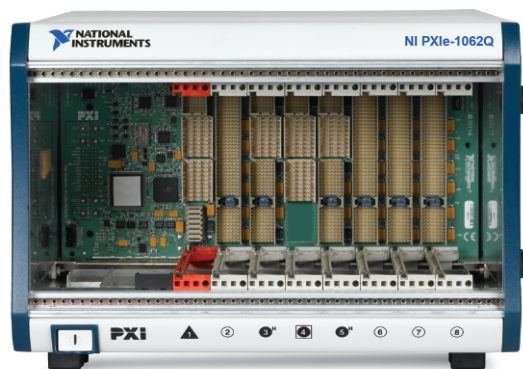

Slot Type	PXI Express System	PXI Express Peripheral	Hybrid	PXI
Bus Signaling	PCI Express (x4)	PCI Express (x4)	PCI (32/33) PCI Express (x4)	PCI (32/33)
Maximum, Theoretical Bandwidth, Single Direction	3 GB/s dedicated for PXI Express [3 x4 links] 132 MB/s shared for PXI	1 GB/s dedicated	132 MB/s shared (PXI) or 1 GB/s dedicated (PXI Express)	132 MB/s shared
Number of Slots	1	1 ¹	2	4

¹ System timing slot

Overview

The National Instruments PXIe-1062Q 8-slot chassis is designed to meet the needs of a wide range of test and measurement applications, providing a high-bandwidth backplane to meet high-performance needs. The NI PXIe-1062Q chassis works with both PXI and PXI Express modules and can operate in a temperature range extended to 55 °C. In addition, for applications requiring quieter operation, the NI PXIe-1062Q can provide acoustic emissions as low as 43.6 dBA at temperatures below 30 °C. The NI PXIe-1062Q chassis incorporates all features of the latest PXI specification including acceptance of both PXI and PXI Express modules with a built-in 10 MHz reference clock, PXI trigger bus, and PXI star trigger for PXI modules and a built-in 100 MHz reference clock, SYNC 100, and PXI differential star trigger for PXI Express modules.

Slot Types Accept PXI and PXI Express Modules

The NI PXIe-1062Q chassis is designed to meet high-bandwidth needs and provides the flexibility to house both PXI and PXI Express modules. The PXI Express system slot provides three x4 PCI Express links (1 GB/s single direction per link) and a x1 PCI Express link to a PCI Express-to-PCI translation bridge on the backplane. The PXI Express system timing slot provides a x4 PCI Express link to the system slot and accepts a PXI Express module or a PXI Express system timing controller for advanced timing and synchronization. The two PXI Express hybrid slots provide connectivity to either a x4 PCI Express link to the system slot or to the 32-bit/33 MHz PCI bus on the backplane. The four remaining PXI slots provide connectivity to the 32-bit/33 MHz PCI bus on the backplane.

8-Slot PXI Express Chassis for PXI and PXI Express Modules

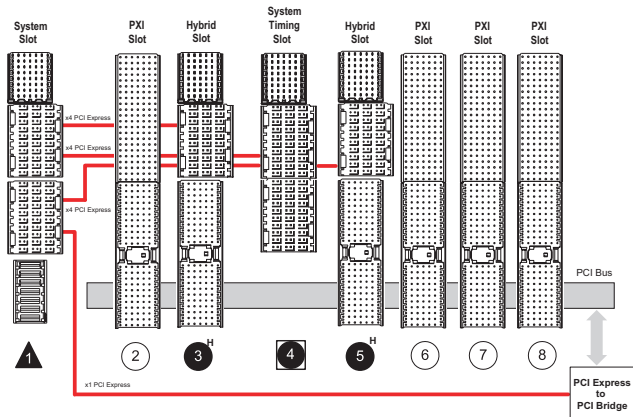

Figure 1. NI PXIe-1062Q Chassis Backplane

Optimized Cooling and Acoustic Emissions

The NI PXIe-1062Q chassis integrates two pulse-width modulation (PWM) system fans to provide forced-air cooling that meets the increased cooling demands of PXI Express and CompactPCI Express. The NI PXIe-1062Q offers a HIGH fan setting to maximize cooling at any ambient temperature and an AUTO fan setting to minimize acoustic emissions at ambient temperatures below 30 °C. The chassis monitors air intake temperature and adjusts fan speed accordingly. With this technology, the NI PXIe-1062Q achieves acoustic noise levels as low as 43.6 dBA (sound pressure level measured at operator position according to ISO 7779). The lower acoustic emissions make the NI PXIe-1062Q ideally suited for office, laboratory, or benchtop applications while the high cooling performance makes the NI PXIe-1062Q well-suited for applications requiring extended temperature ranges.

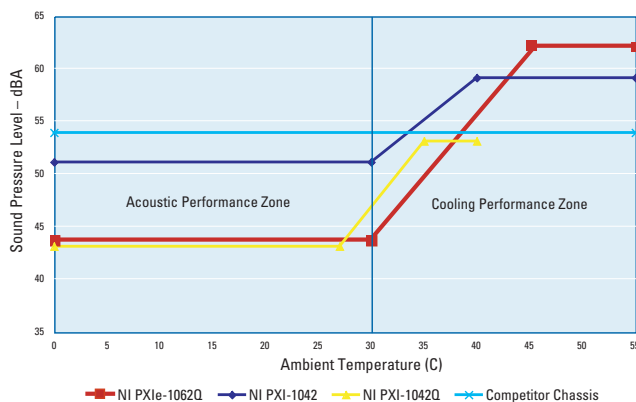

Figure 2. Chassis Acoustic Emissions Comparison

PXI Timing and Synchronization

For PXI modules, the NI PXIe-1062Q backplane provides the standard PXI timing and synchronization features. The chassis features a 10 MHz reference clock (PXI_CLK10) with an accuracy of ± 25 parts per million (ppm), less than 5 ps jitter, and a maximum slot-to-slot skew of 250 ps. For triggering and handshaking needs, the NI PXIe-1062Q provides the PXI trigger bus and PXI star trigger. For PXI Express modules, in addition to PXI timing and synchronization features, the NI PXIe-1062Q backplane supplies a differential 100 MHz reference clock (PXIe_CLK100) with an accuracy of ± 25 ppm, less than 5 ps jitter, and a maximum slot-to-slot skew of 100 ps. The chassis also provides differential star trigger to the PXI Express slots to offer less than 150 ps intermodule skew. With the PXIe_SYNC100, a module installed in the NI PXIe-1062Q can generate its own CLK10 signal, deriving it from the 100 MHz reference clock.

Software System Configuration

The NI PXIe-1062Q chassis is configured with NI Measurement & Automation Explorer (MAX). With this software configuration tool, you can easily configure NI PXIe-1062Q systems without time-consuming manual installation of initialization files. MAX creates the pxisys.ini file that defines the layout and parameters of your PXI system including chassis, controller, and plug-in modules.

Replaceable Power Supply Shuttle

The NI PXIe-1062Q chassis include a removable high-performance universal AC power supply with built-in overcurrent protection. An isolated 12 VDC line provides power to the cooling fans, significantly reducing electrical noise on the chassis backplane. The NI PXIe-1062Q incorporates the power supply and fans into a single modular unit that you can replace quickly, resulting in a mean time to repair (MTTR) of less than five minutes.

External 10 MHz Reference Clock I/O Connectors

The NI PXIe-1062Q chassis include IN/OUT BNC connectors for the 10 MHz reference clock on the rear of the chassis. When the backplane detects a 10 MHz signal on the IN connector, it phase locks PXI_CLK10, PXIe_CLK100, and PXIe_SYNC100 to the external clock. The OUT connector provides a buffered, non-TTL version of the 10 MHz reference clock.

8-Slot PXI Express Chassis for PXI and PXI Express Modules

Remote Power Inhibit and Monitoring

The NI PXIe-1062Q chassis features remote power inhibit and voltage monitoring through a DB-9 connector on the rear of the chassis. Use this connector to switch off power or monitor the power remotely in the chassis.

Power Supply, Temperature, and Fan Monitoring

The NI PXIe-1062Q chassis monitors power supply voltages, air intake temperature, and fan speeds; and provides any failure feedback to the user via a bicolor LED located in the power switch button on the front of the chassis.

Chassis Installation

The NI PXIe-1062Q has a flexible design for easy installation in a variety of applications. For benchtop use, you can adjust the supporting feet to tilt the chassis for more comfortable access to module front panels. Front and rear rack-mount kits are available for 19 in. rack-mounted applications.

PXI Factory Installation Services

With National Instruments Factory Installation Services (FIS), you receive complete system-level assembly and functional testing of the PXI chassis, controller, and all peripheral devices, as well as installation of all device drivers and software programs (such as National Instruments LabVIEW software). For online configuration of a complete PXI system, including information about FIS, visit the PXI Advisor at ni.com/advisor.

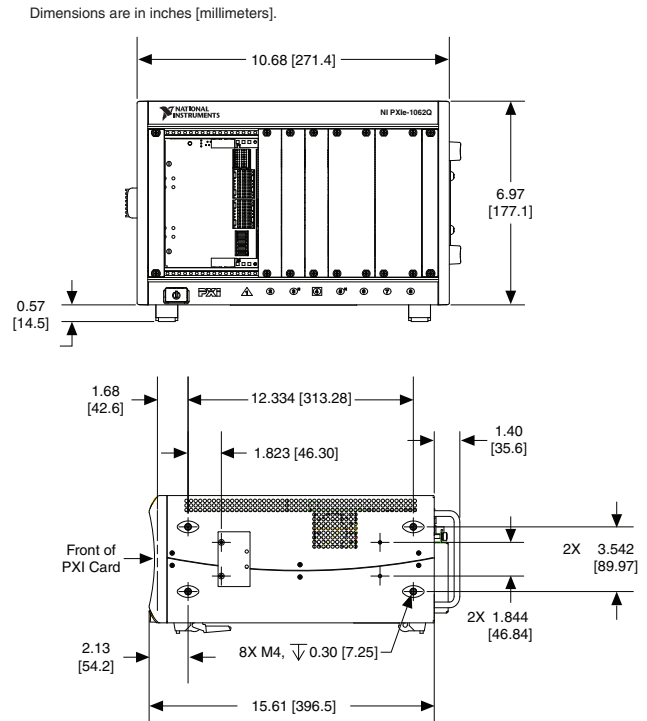

Figure 3. NI PXIe-1062Q Dimensional Drawings

Ordering Information

Step 1. Select your chassis.

NI PXIe-1062Q779633-01

Step 2. Select one or more power cords.

U.S. 120 VAC763000-01
 Japan 100 VAC763000-01
 United Kingdom 240 VAC763064-01
 Swiss 220 VAC763065-01
 Australian 240 VAC763066-01
 Universal Euro 240 VAC763067-01
 North American 240 VAC763068-01

Step 3. Select additional accessories.

Front rack-mount kit (for 19 in. rack)778643-01
 Rear rack-mount kit (for 19 in. rack)778643-02
 NI PXIe-1062Q¹ spare power shuttle779664-01

EMC filler panels (6 single-slot).....778700-01
 Filler panels (3 double-slot and 3 single-slot)²778679-01
 Slot blockers (2 single-slot)³778678-01

¹ NI PXIe-1062Q power shuttles are not compatible with previous generations of NI 8-slot chassis.

² Every NI PXIe-1062Q comes with 3 double-slot and 3 single-slot filler panels.

³ Slot blockers are optional for improved thermal performance of your NI PXIe-1062Q. Refer to National Instruments KnowledgeBase entry on slot blocker usage criteria on ni.com/support for additional information on this optional system feature.

Step 4. Select system setup and installation services.

If you are ordering this chassis as part of a system, select NI Factory Installation Services to have your hardware/software installed and receive your new PXI system ready to use right out of the box.

NI Factory Installation Services – PXI Systems.....960596-01

BUY NOW!

For complete product specifications, pricing, and accessory information, call (800) 813 3693 (U.S.) or go to ni.com/pxi.

8-Slot PXI Express Chassis for PXI and PXI Express Modules

NI PXIe-1062Q Specifications

Electrical

AC Input

Input voltage range.....	100 to 240 VAC
Operating voltage range ¹	90 to 264 VAC
Input frequency	50/60 Hz
Operating frequency range ¹	47 to 63 Hz
Input current rating.....	8 A
Overcurrent protection.....	10 A circuit breaker
Line regulation	
3.3 V	<±0.2%
5 V	<±0.1%
±12 V	<±0.1%
Efficiency.....	70% typical
Power disconnect.....	The AC power cable provides main power disconnect. The front-panel power switch causes the internal chassis power supply to provide DC power to the CompactPCI/PXI Express backplane. You also can use the rear-panel D-Sub 9-pin connector and power mode switch to control the internal chassis power supply.

¹The operating range is guaranteed by design.

DC Output

DC current capacity (I_{MP})

Voltage (V)	Maximum Current (A)
+3.3	26
+5	27
+12	19
-12	1.5
5 (V _{AUX})	1.5

Notes:

Maximum combined +3.3, +5, and +12 V power is 345 W.
 Maximum total power is 353.6 W.
 The maximum power dissipated in the system slot should not exceed 140 W.
 The maximum power dissipated in a peripheral slot should not exceed 30 W.

Backplane Pin Current Capacity

Slot	Current (A)					
	+5 V	V(I/O)	+3.3 V	+12 V	-12 V	5 V _{AUX}
System Controller Slot	9	0	9	11	0	1
System Timing Slot	0	0	3	2	0	1
Hybrid Peripheral Slot with PXI Peripheral	6	5	6	1	1	0
Hybrid Peripheral Slot with PXI Express Peripheral	0	0	3	2	0	1
PXI Peripheral Slot	6	11	6	1	1	0

Load Regulation

Voltage (V)	Load Regulation (%)
+3.3	<5
+12	<5
+5	<5
-12	<5

8-Slot PXI Express Chassis for PXI and PXI Express Modules

Maximum Ripple and Noise (20 MHz bandwidth)

Voltage (V)	Maximum Ripple and Noise (mV _{pp})
+3.3	50
+12	120
+5	50
-12	120

Overcurrent protection.....	All outputs protected from short circuit and overload with automatic recovery
Overvoltage protection	
3.3 and 5 V.....	Clamped at 20 to 30% above nominal output voltage
Power-supply shuttle MTTR	Replacement in under 5 minutes

System Synchronization Clocks (PXI_CLK10, PXIe_CLK100, PXIe_SYNC100)

PXI_CLK10

Maximum slot-to-slot skew	250 ps
Accuracy	±25 ppm max. (guaranteed over operating temperature range)
Maximum jitter.....	5 ps _{rms} phase-jitter (10 Hz to 1 MHz)

For other specifications, the NI PXIe-1062Q complies with the PXI-1 PXI Hardware Specification.

PXIe_CLK100, PXIe_SYNC100

Maximum slot-to-slot skew	100 ps
Accuracy	±25 ppm max. (guaranteed over operating temperature range)
Maximum jitter.....	3 ps _{rms} phase-jitter (10 Hz to 12 kHz) 2 ps _{rms} phase-jitter (12 kHz to 20 MHz)

For other specifications, the NI PXIe-1062Q complies with the PXI-5 PXI Express Hardware Specification.

External 10 MHz REF OUT (BNC on rear panel of chassis)

Accuracy	±25 ppm max. (guaranteed over operating temperature range)
Maximum jitter.....	5 ps _{rms} phase-jitter (10 Hz to 1 MHz)
Output amplitude.....	1 V _{pp} ± 20% square wave into 50 Ω 2 V _{pp} unloaded
Output impedance	50 ± 5 Ω

External Clock Source

Frequency.....	10 MHz ± 100 ppm
Input amplitude	
Rear panel BNC.....	200 mV _{pp} to 5 V _{pp} square wave or sine wave
System timing slot PXI_CLK10_IN	5 V or 3.3 V TTL signal
Rear panel BNC input impedance.....	50 ± 5 Ω
Maximum jitter introduced by backplane	1 ps _{rms} (10 Hz to 1 MHz)

PXI Star Trigger

Maximum slot-to-slot skew	250 ps
For PXI slot-to-PXI star mapping, consult the NI PXIe-1062Q User Manual.	
For other specifications, the NI PXIe-1062Q complies with the PXI-1 PXI Hardware Specification.	

PXI Differential Star Triggers (NI PXIe_DSTAR_A, NI PXIe_DSTAR_B, NI PXIe_DSTAR_C)

Maximum slot-to-slot skew	150 ps
Maximum differential skew	25 ps
For PXI Express slot-to-PXI_DSTAR mapping, consult the NI PXIe-1062Q User Manual.	
For other specifications, the NI PXIe-1062Q complies with the PXI-5 PXI Express Hardware Specification.	

Cooling

Per-slot cooling capacity.....	30 W
Fans	Forced (positive pressurization) via two 110 cfm fans with filters

8-Slot PXI Express Chassis for PXI and PXI Express Modules

Environmental

Operating location	Indoor use
Maximum altitude.....	2,000 m (at 25 °C ambient)
Measurement category.....	II
Pollution degree.....	2

Operating Environment

Ambient temperature range	0 to 55 °C (tested in accordance with IEC-60068-2-1 and IEC-60068-2-2; meets MIL-PRF-28800F Class 3 low temperature limit and MIL-PRF-28800F Class 2 high temperature limit)
Relative humidity range.....	10 to 90%, noncondensing (tested in accordance with IEC-60068-2-56)

Storage Environment

Ambient temperature range	-40 to 71 °C (tested in accordance with IEC-60068-2-1 and IEC-60068-2-2; meets MIL-PRF-28800F Class 3 limits)
Relative humidity range.....	5 to 95%, noncondensing (tested in accordance with IEC-60068-2-56)

Shock and Vibration

Operational shock	30 g peak, half-sine, 11 ms pulse (tested in accordance with IEC-60068-2-27; meets MIL-PRF-28800F Class 2 limits)
-------------------------	---

Random Vibration

Operating	5 to 500 Hz, 0.3 g _{rms}
Nonoperating	5 to 500 Hz, 2.4 g _{rms} (tested in accordance with IEC-60068-2-64; nonoperating test profile exceeds the requirements of MIL-PRF-28800F, Class 3)

Acoustic Emissions

(Tested in accordance with ISO 7779. Meets MIL-PRF-28800F requirements.)

Sound Pressure Level (at Operator Position)

NI PXIe-1062Q	
Auto fan (up to 30 °C ambient).....	43.6 dBA
High fan	62 dBA

Sound Power

Auto fan (up to 30 °C ambient)	52.8 dBA
High fan.....	72 dBA

Safety

The NI PXIe-1062Q chassis was evaluated using the criteria of EN 61010-1 and meets the requirements of the following standards for safety and electrical equipment for measurement, control, and laboratory use:

- EN 61010-1, IEC 61010-1
- UL 61010-1
- CAN/CSA C22.2 No. 61010-1

Note: For UL and other safety certifications, refer to the product label, or visit ni.com/hardref.nsf/, search by model number or product line, and click the appropriate link in the Certification column.

Electromagnetic Compatibility

Emissions	EN 55011 Class A at 10 m FCC Part 15A above 1 GHz
Immunity	EN 61326:1997 + A2:2001, Table 1
EMC/EMI.....	CE, C-Tick, and FCC Part 15 (Class A) Compliant
Harmonics/flicker.....	EN 61000-3-2 and EN 61000-3-3

Note: For EMC compliance, you must operate this device with shielded cabling. In addition, all covers and filler panels must be installed.

8-Slot PXI Express Chassis for PXI and PXI Express Modules

CE Compliance

This product meets the essential requirements of applicable European Directives, as amended for CE marking, as follows:

Low-Voltage Directive (safety) 73/23/EEC

Electromagnetic Compatibility

Directive (EMC) 89/336/EEC

Note: Refer to the Declaration of Conformity (DoC) for this product for any additional regulatory compliance information. To obtain the DoC for this product, visit ni.com/hardref.nsf/, search by model number or product line, and click the appropriate link in the Certification column.

Specifications subject to change without notice.

NI Services and Support



NI has the services and support to meet your needs around the globe and through the application life cycle – from planning and development through deployment and ongoing maintenance. We offer services and service levels to meet customer requirements in research, design, validation, and manufacturing. Visit ni.com/services.

Training and Certification

NI training is the fastest, most certain route to productivity with our products. NI training can shorten your learning curve, save development time, and reduce maintenance costs over the application life cycle. We schedule instructor-led courses in cities worldwide, or we can hold a course at your facility. We also offer a professional certification program that identifies individuals who have high levels of skill and knowledge on using NI products. Visit ni.com/training.

Professional Services

Our Professional Services Team is comprised of NI applications engineers, NI Consulting Services, and a worldwide National Instruments Alliance Partner program of more than 600 independent consultants and

integrators. Services range from start-up assistance to turnkey system integration.

Visit ni.com/alliance.



OEM Support

We offer design-in consulting and product integration assistance if you want to use our products for OEM applications. For information about special pricing and services for OEM customers, visit ni.com/oem.

Local Sales and Technical Support

In offices worldwide, our staff is local to the country, giving you access to engineers who speak your language. NI delivers industry-leading technical support through online knowledge bases, our applications engineers, and access to 14,000 measurement and automation professionals within NI Developer Exchange forums. Find immediate answers to your questions at ni.com/support.

We also offer service programs that provide automatic upgrades to your application development environment and higher levels of technical support. Visit ni.com/ssp.

Hardware Services

NI Factory Installation Services

NI Factory Installation Services (FIS) is the fastest and easiest way to use your PXI or PXI/SCXI combination systems right out of the box. Trained NI technicians install the software and hardware and configure the system to your specifications. NI extends the standard warranty by one year on hardware components (controllers, chassis, modules) purchased with FIS. To use FIS, simply configure your system online with ni.com/pxiadvisor.

Calibration Services

NI recognizes the need to maintain properly calibrated devices for high-accuracy measurements. We provide manual calibration procedures, services to recalibrate your products, and automated calibration software specifically designed for use by metrology laboratories. Visit ni.com/calibration.

Repair and Extended Warranty

NI provides complete repair services for our products. Express repair and advance replacement services are also available. We offer extended warranties to help you meet project life-cycle requirements. Visit ni.com/services.



ni.com • (800) 813 3693

National Instruments • info@ni.com

