

GPS, IEEE 1588, and IRIG-B Timing and Synchronization Modules for PXI and PXI Express

NI PXI-6682, NI PXI-6682H

- Synchronize PXI and PXI Express systems using GPS, IEEE 1588-2008, IRIG-B, or PPS
- Available for PXI systems, PXI-6682, and for PXI Express systems, PXI-6682H
- Onboard routing of internal and external clock and trigger signals
- Can be used as PXI slot 2 star trigger controller (not available on PXI-6682H)
- Onboard high-stability 10 MHz reference (1 ppm)

Operating Systems

- Windows 7/Vista/XP

Recommended Software

- LabVIEW
- LabWindows™/CVI

Driver Software (included)

- NI-Sync

PXI System Configuration

- Complete PXI system configuration at ni.com/pxiadvisor



>>For complete specifications and compliance information, see appendix A in the NI PXI-6682 user manual at ni.com/manuals.

Overview

The NI PXI-6682 and PXI-6682H timing and synchronization modules synchronize PXI and PXI Express systems using GPS, IEEE 1588, IRIG-B, or PPS to perform synchronized events. You can use them to generate events and clock signals at specified synchronized future times and timestamp input events with the synchronized system time. When installed in slot 2 of a PXI chassis, the NI PXI-6682 routes clock signals and triggers with low skew within a PXI chassis

or between multiple chassis, providing a method for synchronizing multiple devices in a PXI system. Because of this, you can greatly improve the accuracy of measurements, implement advanced triggering schemes, or synchronize multiple devices and/or multiple chassis to act as a single system for high-channel-count applications. Table 1 compares the features of different NI timing and synchronization product offerings.

| Features | NI PXI-6651 | NI PXI-6652 | NI PXI-6653 | NI PXIe-6672 | NI PXI-6682/H |
|---------------------------------------|-------------|---------------------|---------------------|---------------------|----------------|
| Front Panel Connectivity | | | | | |
| CLK in | ✓ | ✓ | ✓ | ✓ | ✓ ² |
| CLK out | – | ✓ | ✓ | ✓ | ✓ |
| General-purpose PFI lines | 2 SMB | 6 SMB | 6 SMB | 6 SMB | 3 SMB |
| GPS, IEEE 1588, IRIG-B | – | – | – | – | ✓ |
| Time References | | | | | |
| GPS | – | – | – | – | ✓ |
| IEEE 1588 | – | – | – | – | ✓ |
| IRIG-B | – | – | – | – | ✓ |
| Programmable Voltage Threshold | | | | | |
| | ✓ | ✓ | ✓ | ✓ | |
| Trigger Routing | | | | | |
| Star trigger source (PXI_STAR) | ✓ | ✓ | ✓ | ✓ | ✓ ² |
| PXI trigger bus (PXI_TRIG) | ✓ | ✓ | ✓ | ✓ | ✓ |
| Onboard Clock Sources | | | | | |
| 10 MHz timebase | – | TCXO (1 ppm) | OCXO (50 ppb) | TCXO (1 ppm) | TCXO (1 ppm) |
| Programmable clock ¹ | – | DC to 105 MHz (DDS) | DC to 105 MHz (DDS) | DC to 105 MHz (DDS) | DC to 1.5 MHz |

¹Frequency resolution of <0.075 Hz for NI PXI-6652, PXI-6653, and PXIe-6672. For NI PXI-6682, the clock period and duty cycle have to be a multiple of 10 ns.

²Not available on the hybrid-compatible version of the module, the PXI-6682H.

Table 1. Features Comparison for Various NI Timing and Synchronization Modules Including the PXI-6682 and PXI-6682H

GPS, IEEE 1588, and IRIG-B Timing and Synchronization Modules for PXI and PXI Express

Synchronize PXI and PXI Express Systems Using GPS, IEEE 1588, or IRIG-B

With the PXI-6682 and PXI-6682H, you can use GPS, IEEE 1588, IRIG-B, or PPS signals as the time reference to synchronize with other devices or PXI and PXI Express systems. You have not only a synchronized clock for multiple PXI and PXI Express systems but also a common time reference. Because of this, you can generate synchronized future time events and timestamp incoming signals with the synchronized time.

The GPS receiver on the PXI-6682 and PXI-6682H can power an active GPS antenna and receive and process the RF signals (1.575 GHz) from satellites. It generates a very precise pulse-per-second (PPS) signal that the PXI-6682 and PXI-6682H use to achieve submicrosecond synchronization. Because of this, you can use the PXI-6682 and PXI-6682H to synchronize spatially located PXI and PXI Express systems as long as GPS satellites are visible to the antenna from those locations. Furthermore, once the PXI-6682 and PXI-6682H are synchronized to GPS, they can function as IEEE 1588 grandmasters to achieve synchronization of external 1588 devices. NI-Sync 3.1 or later supports IEEE 1588-2008. NI-Sync 3.0 is available on the Web for those who need IEEE 1588-2002 support.

PXI-6682 as a Star Trigger Controller

The PXI-6682 provides full control of the timing and synchronization features of the PXI backplane (Figure 3). To act as a PXI star trigger controller or to offer a high-accuracy, free-running 10 MHz reference clock, the PXI-6682 must be installed in slot 2 of the PXI chassis, as shown in Figure 1. It is capable of routing signals to and from the front panel, the PXI star triggers, and the PXI triggers. In addition, you can invert the polarity of the destination signal, which is useful when handling active-low digital signals. The PXI-6682 can also route a 10 MHz clock from CLKIN to the PXI 10 MHz reference clock and route the TCXO or PXI 10 MHz reference clock to CLKOUT. Refer to Figure 2 for the PXI-6682 functional block diagram.



Figure 1. The PXI-6682 is connected to an active GPS antenna and installed in a system timing slot (slot 2) of an NI PXI-1042 chassis.

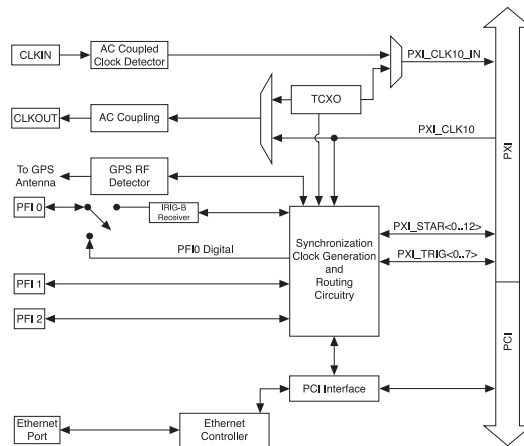

Figure 2. Functional Overview of the PXI-6682

Note: The PXI-6682H does not have PXI_STAR trigger lines, shown as PXI_STAR<0..12> in Figure 2. The PXI-6682H does not have the CLKIN circuitry or the ability to drive PXI_CLK10_IN.

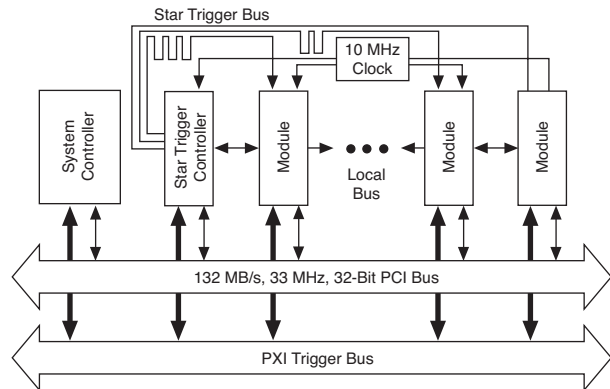

Figure 3. Diagram of Synchronization Features in the PXI Backplane

Synchronizing PXI Express Systems with the PXI-6682H

You can use the PXI-6682H in any PXI hybrid-compatible slot in PXI Express chassis with PXI hybrid slots. By using the PXI-6682H in such a system, you can timestamp events and create future time events on the PXI_TRIG lines as well as reference your system time to GPS, IEEE 1588, or IRIG-B. The PXI-6682H is essentially the same module as the PXI-6682 except NI has removed one connector so the PXI-6682H can plug into PXI Express systems. For this reason, you cannot drive PXI_CLK10, the PXI_STAR trigger lines, or any of the PXI Express clocks and triggers. If you wish to override CLK_10 in a PXI Express system, you can route a coaxial cable from CLKOUT on the PXI-6682H to the 10 MHz clock input on the rear of the PXI Express chassis (if the chassis you have selected has this input). To drive the PXI_STAR trigger lines, you must also incorporate a PXI Express timing module such as the NI PXIe-6672.

GPS, IEEE 1588, and IRIG-B Timing and Synchronization Modules for PXI and PXI Express

Synchronization Accuracy

Table 2 lists the synchronization accuracy that the PXI-6682 and PXI-6682H offer while operating in various modes.

| Mode ¹ | Synchronization Accuracy |
|---|-------------------------------|
| GPS ² | ±100 ns, <13 ns std deviation |
| IEEE 1588 3 m Ethernet direct connection ³ | ±47 ns, <10 ns std deviation |
| IEEE 1588 via hub ^{3,4} | ±210 ns, <35 ns std deviation |
| IEEE 1588 via switch ^{3,5} | ±25 µs, <150 ns std deviation |
| IRIG-B DC | ±55 ns, <13 ns std deviation |
| IRIG-B AM matching ^{6,7} | ±1 µs, <220 ns std deviation |
| IRIG-B AM to source ⁷ | ±5 µs, <500 ns std deviation |
| PPS | ±47 ns, <10 ns std deviation |

¹All synchronization measurements were done by recording the offset between PPS signals generated by two PXI-6682 modules inside a closed NI PXI-1031 chassis at ambient room temperature conditions. Synchronization was performed for 15 minutes before testing began. All test durations were 12 hours.

²For the GPS test, two PXI-6682 modules were independently synchronized to GPS and configured to generate a PPS signal. The specification above represents empirical results. Please note that GPS satellites are guaranteed to be within only 100 ns of UTC. Therefore, the offset between any two synchronized devices can be as high as 200 ns plus the offset of that device to GPS.

³Sync interval of 1 second was used for IEEE 1588 tests, and all Ethernet connections were 100 Mb/s.

⁴Netgear DS104 hub used.

⁵Airlink101 gigabit over copper switch used. For this test, a moderate amount of non-1588 Ethernet traffic was present on the switch.

⁶IRIG-B AM matching specification was obtained by setting two PXI-6682 modules to synchronize independently to the same IRIG-B AM source and generate a PPS signal. The offset between their PPS signals was then measured over a 12-hour period.

⁷IRIG-B performance depends on IRIG-B source stability and quality.

Table 2. NI PXI-6682 and PXI-6682H Synchronization Accuracy

High-Stability 10 MHz Timebase

When configured as a star trigger controller, the PXI-6682 can override the built-in 10 MHz reference clock on a PXI chassis. Most PXI chassis provide a 10 MHz reference clock with 25 ppm accuracy (10 MHz ±250 Hz). This accuracy is improved to 1 ppm with the PXI-6682. Many modules, such as NI PXI-5xxx modular instruments, have phase-locked loop (PLL) circuitry to synchronize with the 10 MHz reference clock.

NI-Sync Software

The included NI-Sync driver software provides powerful yet easy-to-use control of PXI-6682 and PXI-6682H modules. You can use NI application development environment (ADE) software such as LabVIEW or LabWindows/CVI, or other ADEs such as Visual C/C++, for programming the PXI-6682 and PXI-6682H.

For NI-Sync example programs, visit ni.com/examples.

>>For complete specifications and compliance information, see appendix A in the NI PXI-6682 user manual at ni.com/manuals.

Ordering Information

| | |
|---|-----------|
| NI PXI-6682 (GPS, IEEE 1588, IRIG-B) | 779929-01 |
| NI PXI-6682H (GPS, IEEE 1588, IRIG-B)..... | 781059-01 |
| GPS antenna with 30 m coaxial cable | 196304-30 |
| SMB 200 | |
| SMB plug to SMB plug coax, 50 W, 1 m | 188859-01 |
| SMB 210 | |
| Dual SMB plug to dual SMB plug coax, 50 W, 1 m..... | 188858-01 |

BUY NOW

For complete product specifications, pricing, and accessory information, call 800 813 3693 (U.S.) or go to ni.com/pxi.

NI Services and Support



NI has the services and support to meet your needs around the globe and through the application life cycle – from planning and development through deployment and ongoing maintenance. We offer services and service levels to meet customer requirements in research, design, validation, and manufacturing.

Visit ni.com/services.

Training and Certification

NI training is the fastest, most certain route to productivity with our products. NI training can shorten your learning curve, save development time, and reduce maintenance costs over the application life cycle. We schedule instructor-led courses in cities worldwide, or we can hold a course at your facility. We also offer a professional certification program that identifies individuals who have high levels of skill and knowledge on using NI products.

Visit ni.com/training.

Professional Services

Our NI Professional Services team is composed of NI applications and systems engineers and a worldwide National Instruments Alliance Partner program of more than 600 independent consultants and integrators. Services range from



start-up assistance to turnkey system integration. Visit ni.com/alliance.

OEM Support

We offer design-in consulting and product integration assistance if you want to use our products for OEM applications. For information about special pricing and services for OEM customers, visit ni.com/oem.



ni.com ■ 800 813 3693

National Instruments ■ info@ni.com

Local Sales and Technical Support

In offices worldwide, our staff is local to the country, giving you access to engineers who speak your language. NI delivers industry-leading technical support through online knowledge bases, our applications engineers, and access to 14,000 measurement and automation professionals within NI Developer Exchange forums. Find immediate answers to your questions at ni.com/support.

We also offer service programs that provide automatic upgrades to your application development environment and higher levels of technical support. Visit ni.com/ssp.

Hardware Services

System Assurance Programs

NI system assurance programs are designed to make it even easier for you to own an NI system. These programs include configuration and deployment services for your NI PXI, CompactRIO, or Compact FieldPoint system. The NI Basic System Assurance Program provides a simple integration test and ensures that your system is delivered completely assembled in one box. When you configure your system with the NI Standard System Assurance Program, you can select from available NI system driver sets and application development environments to create customized, reorderable software configurations. Your system arrives fully assembled and tested in one box with your software preinstalled. When you order your system with the standard program, you also receive system-specific documentation including a bill of materials, an integration test report, a recommended maintenance plan, and frequently asked question documents. Finally, the standard program reduces the total cost of owning an NI system by providing three years of warranty coverage and calibration service. Use the online product advisors at ni.com/advisor to find a system assurance program to meet your needs.

Calibration Services

NI recognizes the need to maintain properly calibrated devices for high-accuracy measurements. We provide manual calibration procedures, services to recalibrate your products, and automated calibration software specifically designed for use by metrology laboratories. Visit ni.com/calibration.

Repair and Extended Warranty

NI provides complete repair services for our products. Express repair and advance replacement services are also available. We offer extended warranties to help you meet project life-cycle requirements. Visit ni.com/services.