

Pulse Generation Output Module for Compact FieldPoint

NI cFP-PG-522

- 8 outputs
 - 5 to 30 VDC
 - 2 A per channel
 - 5 kHz maximum frequency
- 2,300 V_{rms} bank isolation for transient overvoltage protection
- Hot-swappable with autoconfiguration
- -40 to 70 °C operating range

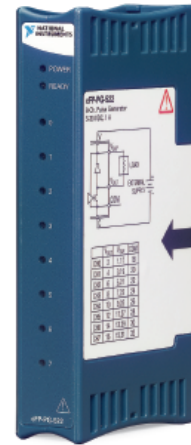

Module	Output Channels	Output Voltages	Output Frequency	Minimum On/Off Time	Output Current (see Specifications)
cFP-PG-522	8	5 to 30 VDC sinking	Up to 5 kHz	100 µs	2 A

Overview

The National Instruments cFP-PG-522 is a versatile pulse generation output module for Compact FieldPoint that you can use to precisely generate a continuous or finite pulse train to control external circuits. The NI cFP-PG-522 module is commonly used to provide an accurate pulse train for frequency measurement, gauge control, and stepper motor control. It includes onboard diagnostics to ensure trouble-free installation and maintenance.

Compact FieldPoint

Compact FieldPoint is designed for industrial control applications that perform advanced embedded control, data logging, headless operation, and Ethernet connectivity. The most rugged and reliable NI platform, Compact FieldPoint, is designed for industrial and mobile environments with high shock, vibration, and temperature extremes.

Pulse Generation Modules

You can program each output of the cFP-PG-522 module to generate a finite number of pulses or to generate pulses continuously. You can programmatically set the on-time and off-time for each output pulse train, set the number of pulses to be sent, and start and stop the pulse train. The on-time and off-time for each output are set as an integer from 1 to 65,535 timebase units, with selectable timebase options of 100 µs, 10 ms, or 1 s. Setting the off-time to zero generates a constant on (high) signal. Each channel also includes a green LED to indicate whether the output is actively generating a pulse train.

Isolation

The cFP-PG-522 module features optical bank isolation with 2,300 V_{rms} of breakdown isolation. It does not have channel-to-channel isolation.

Field I/O Connections

Compact FieldPoint modules include a built-in power distribution bus that provides multiple power connections on the module. A field-wired power supply connected to the voltage (V) and common (C) terminals is internally connected to a power distribution bus that offers additional breakout terminals for voltage supply (V_{SUP}) and common (COM). These terminals deliver a convenient way to distribute power to field devices that require external power.

The cFP-PG-522 has:

- 8 pulse generation digital output terminals (V_{OUT})
- 8 common terminals (COM)
- 16 power connections to power field devices (V)

Pulse Generation Output Module for Compact FieldPoint

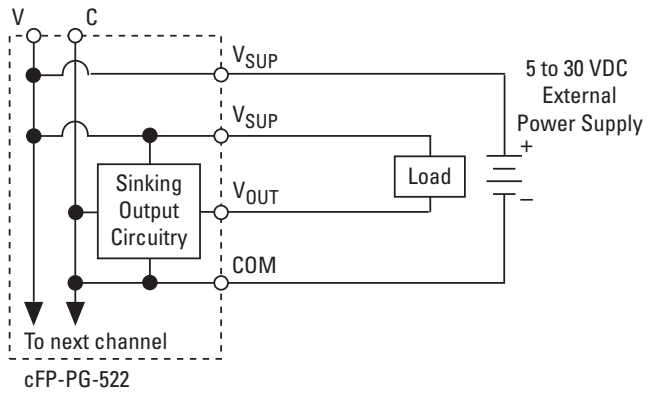

Wiring Schematic for cFP-PG-522 Module

Ordering Information

NI cFP-PG-522.....777318-522

Recommended Compact FieldPoint System Products

NI cFP-2120777317-2120

NI cFP-BP-4.....778617-04

NI cFP-CB-1.....778618-01

NI PS-5 power supply.....778805-90

NI Developer Suite Professional Control Edition777906-03

BUY NOW!

For complete product specifications, pricing, and accessory information, call 800 813 3693 (U.S.) or go to ni.com/compactfieldpoint.

Pulse Generation Output Module for Compact FieldPoint

Specifications

Typical for -40 to 70 °C unless otherwise noted.

Output Characteristics

Number of channels.....	8
Output type	5 to 30 VDC, sinking
Supply voltage	5 to 30 VDC, user-provided
Maximum output current	
Per channel	2 A per channel
All channels	16 A ² (8 A ² for cFP-PG-522 operating at 60 to 70 °C)
Output impedance.....	0.12 Ω
Pulse-width accuracy.....	±5 μs, any pulse settings
Pulse-frequency accuracy	0.007%, any pulse settings
Leakage current	100 μA

Power Requirements

Power from network module	420 mW
---------------------------------	--------

Physical Characteristics

LED indicators	
POWER (green)	Power on and self-test passed
READY (green)	Module configured and ready
Output <0...7> (green).....	Pulsing active on channel
Dimensions.....	127.0 by 65.9 by 23.9 mm (5.00 by 2.60 by 0.94 in.)
Weight.....	100 g (3.5 oz)

Isolation Voltage

Channel-to-channel isolation.....	No isolation between channels
Transient overvoltage.....	2,300 V _{rms}

Environment

Operating temperature	-40 to 70 °C
Storage temperature.....	-55 to 85 °C
Humidity	10 to 90%, noncondensing

Safety and Compliance

Safety

This product is designed to meet the requirements of the following standards of safety for electrical equipment for measurement, control, and laboratory use:

- IEC 61010-1, EN 61010-1
- UL 61010-1, CSA 61010-1

Note: For UL and other safety certifications, refer to the product label or visit ni.com/certification, search by model number or product line, and click the appropriate link in the Certification column.

Electromagnetic Compatibility

This product is designed to meet the requirements of the following standards of EMC for electrical equipment for measurement, control, and laboratory use:

- EN 61326 EMC requirements; Minimum Immunity
- EN 55011 Emissions; Group 1, Class A
- CE, C-Tick, ICES, and FCC Part 15 Emissions; Class A

Note: For EMC compliance, operate this device according to product documentation.

CE Compliance

This product meets the essential requirements of applicable European Directives, as amended for CE marking, as follows:

- 2006/95/EC; Low-Voltage Directive (safety)
- 2004/108/EC; Electromagnetic Compatibility Directive (EMC)

Note: Refer to the Declaration of Conformity (DoC) for this product for any additional regulatory compliance information. To obtain the DoC for this product, visit ni.com/certification, search by model number or product line, and click the appropriate link in the Certification column.

Waste Electrical and Electronic Equipment (WEEE)

EU Customers: At the end of their life cycle, all products must be sent to a WEEE recycling center. For more information about WEEE recycling centers and National Instruments WEEE initiatives, visit ni.com/environment/weee.htm.

NI Services and Support



NI has the services and support to meet your needs around the globe and through the application life cycle – from planning and development through deployment and ongoing maintenance. We offer services and service levels to meet customer requirements in research, design, validation, and manufacturing. Visit ni.com/services.

Training and Certification

NI training is the fastest, most certain route to productivity with our products. NI training can shorten your learning curve, save development time, and reduce maintenance costs over the application life cycle. We schedule instructor-led courses in cities worldwide, or we can hold a course at your facility. We also offer a professional certification program that identifies individuals who have high levels of skill and knowledge on using NI products. Visit ni.com/training.

Professional Services

Our NI Professional Services team is composed of NI applications and systems engineers and a worldwide National Instruments Alliance Partner program of more than 600 independent consultants and

integrators. Services range from start-up assistance to turnkey system integration. Visit ni.com/alliance.



OEM Support

We offer design-in consulting and product integration assistance if you want to use our products for OEM applications. For information about special pricing and services for OEM customers, visit ni.com/oem.

Local Sales and Technical Support

In offices worldwide, our staff is local to the country, giving you access to engineers who speak your language. NI delivers industry-leading technical support through online knowledge bases, our applications engineers, and access to 14,000 measurement and automation professionals within NI Developer Exchange forums. Find immediate answers to your questions at ni.com/support.

We also offer service programs that provide automatic upgrades to your application development environment and higher levels of technical support. Visit ni.com/ssp.

Hardware Services

NI Factory Installation Services

NI Factory Installation Services (FIS) is the fastest and easiest way to use your PXI or PXI/SCXI combination systems right out of the box. Trained NI technicians install the software and hardware and configure the system to your specifications. NI extends the standard warranty by one year on hardware components (controllers, chassis, modules) purchased with FIS. To use FIS, simply configure your system online with ni.com/pxiadvisor.

Calibration Services

NI recognizes the need to maintain properly calibrated devices for high-accuracy measurements. We provide manual calibration procedures, services to recalibrate your products, and automated calibration software specifically designed for use by metrology laboratories. Visit ni.com/calibration.

Repair and Extended Warranty

NI provides complete repair services for our products. Express repair and advance replacement services are also available. We offer extended warranties to help you meet project life-cycle requirements. Visit ni.com/services.



ni.com • 800 813 3693

National Instruments • info@ni.com

