

TECHSPEC® COMPACT FIXED FOCAL LENGTH LENSES

Designed for machine vision applications, our TECHSPEC® Compact Fixed Focal Length lenses have been optically designed with the working distance and resolution requirements of factory automation and inspection in mind. Featuring large maximum apertures, these high performance lenses can be used in even the most restrictive lighting conditions. Each lens has a broadband anti-reflection coating, which increases transmission by up to 12 percent over the standard MgF₂ coating on competitive lenses.

The TECHSPEC® Compact Fixed Focal Length lenses feature locking iris and focus adjustment, with optional recessed set screws to prevent unintentional lens adjustments. The lens housing is ruggedized and robust, yet compact enough for space-restrictive applications. Each lens is manufactured to a high tolerance, resulting in high levels of imaging performance and low lens-to-lens variation, assuring simple installation into multiple systems.

Combining high optical performance, industrial features and small package size, these lenses represent a new standard in factory automation optics.



- Industry Leading Price to Performance Ratio
- Designed for True Factory Automation
- Supports up to 2/3" Sensors
- Ruggedized Housing
- Large Maximum Aperture
- Low Lens-to-Lens Variation

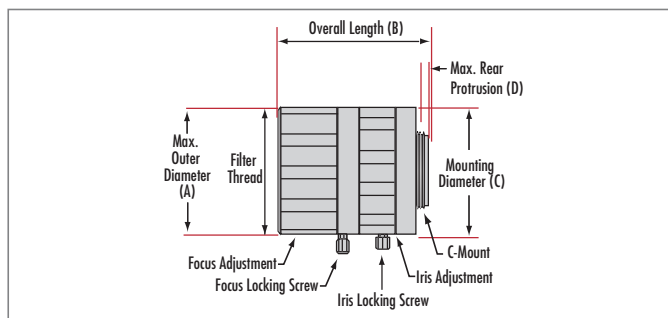

Focal Length	A	B	C	D
8.5mm	35.0mm	34.5mm	32.0mm	0mm
12mm	32.0mm	27.9mm	32.0mm	0.5mm
16mm	33.0mm	37.5mm	33.0mm	1.0mm
25mm	31.0mm	31.2mm	31.0mm	1.3mm
35mm	33.0mm	36.1mm	33.0mm	0mm



TECHSPEC® COMPACT FIXED FOCAL LENGTH LENSES								*Horizontal
Focal Length	Max Sensor Format	FOV* Range on 2/3" Sensor	FOV* Range on 1/2" Sensor	FOV* Range on 1/3" Sensor	Working Distance	Aperture (f/#)	Filter Thread	Stock Number
8.5mm	2/3"	213mm - 60.8°	155mm - 43.8°	116.1mm - 33.1°	200mm - ∞	F1.3 - F16	M25.5 x 0.5mm	#58-000
12mm	2/3"	152mm - 41.4°	110.5mm - 30.3°	82.8mm - 22.6°	200mm - ∞	F1.8 - F16	M25.5 x 0.5mm	#58-001
16mm	2/3"	77.6mm - 31°	56.2mm - 22.5°	42.3mm - 16.9°	100mm - ∞	F1.4 - F16	M25.5 x 0.5mm	#59-870
25mm	2/3"	43.4mm - 20.7°	31.2mm - 14.6°	23.7mm - 11.3°	100mm - ∞	F1.4 - F17	M25.5 x 0.5mm	#59-871
35mm	2/3"	48.2mm - 14.4°	35.0mm - 10.4°	26.3mm - 7.8°	165mm - ∞	F1.65 - F22	M25.5 x 0.5mm	#59-872

Contact us Today for A Volume Quote



800.363.1992 | www.edmundoptics.com

TECHSPEC® COMPACT FIXED FOCAL LENGTH LENSES

TECHSPEC® COMPACT FIXED FOCAL LENGTH LENSES

High levels of optical performance are critical for successful imaging solutions. Edmund Optics® has taken care to maintain optical performance in our CFF's, across the entire image plane. Resolution and contrast typically deteriorate at the corners of an images, thus both the center and corners of an image must be considered when comparing overall lens performance.

Shown below are comparisons of our TECHSPEC® Compact Fixed Focal Length Lens at the center and the corner of the images to the performance of various competitor lenses. Edmund Optics® lenses show a 30% increase in contrast over the closest competitor at the center of the image. Additionally, Edmund Optics® lenses show over twice the contrast in the corner making our Compact Fixed Focal Length Lens ideal from the most simple to the most complex applications. All tests are done with a 16mm lens at f/2 on a 1.3MP, 1/2" sensor camera and 1.5" field of view.



Ronchi Ruling Comparison Test Setup

RESOLUTION AND CONTRAST COMPARISON OF COMPACT FIXED FOCAL LENSES

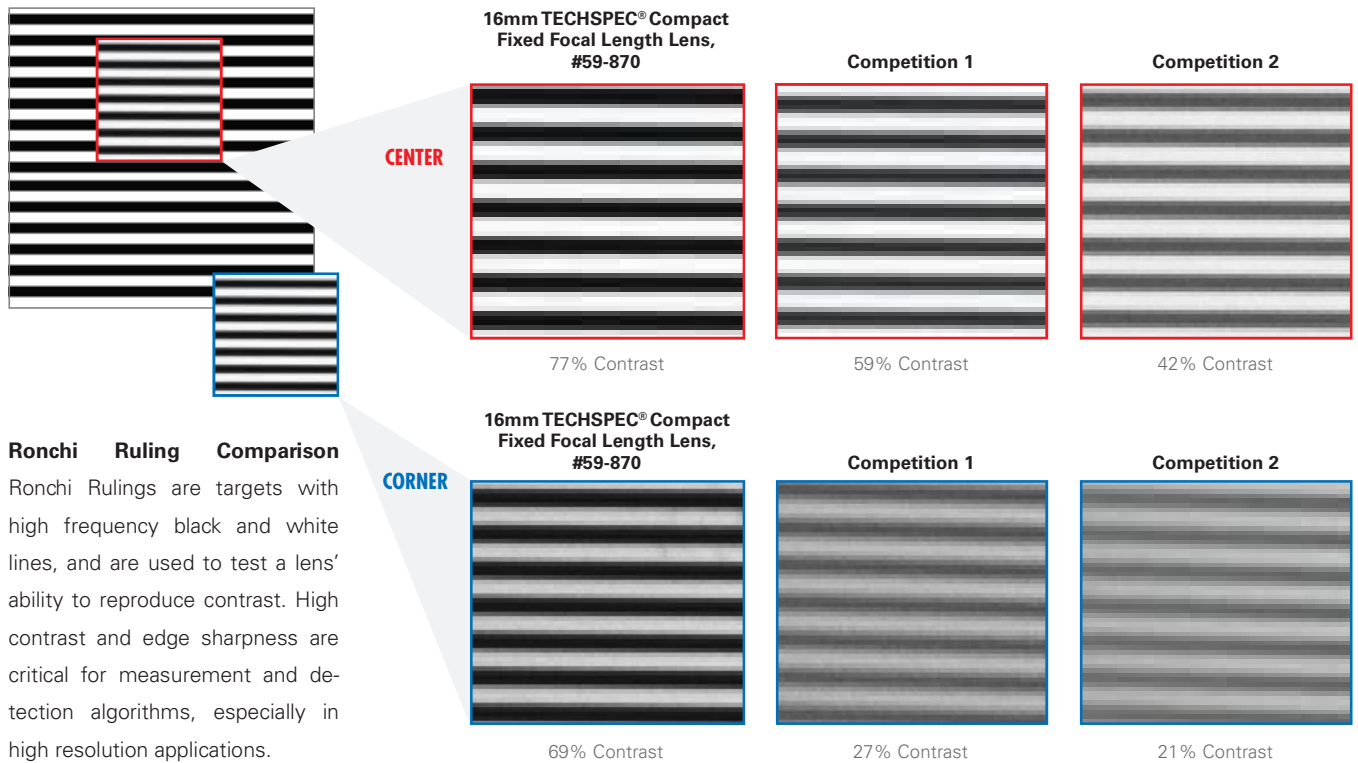

Ronchi Ruling Comparison

Ronchi Rulings are targets with high frequency black and white lines, and are used to test a lens' ability to reproduce contrast. High contrast and edge sharpness are critical for measurement and detection algorithms, especially in high resolution applications.