

# Digital Input Modules for Compact FieldPoint and FieldPoint

## NI [c]FP-DI-300, NI [c]FP-DI-301, NI [c]FP-DI-330

NEW

- 8 or 16 inputs
  - 24 VDC inputs
  - 3 to 250 VDC inputs
  - 15 to 250 VAC inputs
- 2,300 V<sub>rms</sub> bank isolation for transient overvoltage protection
- Hot swappable with autoconfiguration
- -40 to 70 °C operating range



Module	Input Channels	Input Ranges	Inputs Type	Compatibility Examples	Separate Ground Plane per Channel	All Channel Update Rate
[c]FP-DI-300	8	18 to 30 VDC	Sinking	24 VDC sourcing devices	–	1 kHz
[c]FP-DI-301	16	18 to 30 VDC	Sinking	24 VDC sourcing devices	–	1 kHz
[c]FP-DI-330	8	3 to 250 VDC 15 to 250 VAC	Sinking or sourcing	TTL, CMOS, 12 VDC, 24 VDC, 48 VDC, 120/240 VAC/VDC	✓	1 kHz

## Overview

The National Instruments [c]FP-DI-3xx devices are versatile digital input modules for Compact FieldPoint and FieldPoint that can be used to monitor digital signals ranging from low voltage levels up to 250 V. These modules are commonly used to monitor proximity and limit switches, pushbutton switches, thermostat outputs, relay closure, power circuits, and TTL devices. All the modules include onboard diagnostics to ensure trouble-free installation and maintenance.

## Digital Input Modules

DI-3xx modules provide built-in module-to-module isolation to protect your FieldPoint system and controller or communication interface from high voltage levels.

The DI-300 and DI-301 modules use a common ground plane for all the input channels. Each channel on the DI-300 and the DI-301 includes current-limiting circuitry to prevent damaging the module when connecting it directly to a 24 VDC source.

The DI-330 uses eight optically isolated input channels so that each digital input has a separate ground plane and each channel can be used with a different voltage potential. Thus, you can connect one channel to a 5 VDC TTL signal and another signal on the same DI-330 module to a 250 VAC line voltage. Each channel on the DI-330 includes current-limiting circuitry that limits the total current to 1.5 mA to prevent damaging the module.

All the channels on the DI-3xx modules feature LEDs that indicate the input state of each channel. The modules all feature an all channel update rate of 1 kHz. Overall data throughput depends on software loop speeds and network speeds.

## Isolation

DI-3xx modules feature optical bank isolation with 2,300 V<sub>rms</sub> of breakdown isolation. In addition, the DI-330 provides double insulation for up to 250 V<sub>rms</sub> of operational isolation. Compact FieldPoint can safely be used in applications where hazardous voltages are present when used with the cFP-CB-1 connector block. FieldPoint can safely be used in applications where hazardous voltages are present with the FP-TB-x terminal base. These Compact FieldPoint and FieldPoint modules do not have channel-to-channel isolation.

## Field I/O Connections

Compact FieldPoint and FieldPoint modules include a built-in power distribution bus that provides multiple power connections on the module. A field wired power supply connected to the voltage (V) and common (C) terminals is internally connected to a power distribution bus that provides additional breakout terminals for voltage supply (V<sub>SUP</sub>) and common (COM). These terminals provide a convenient way to distribute power to field devices that require external power.

# Digital Input Modules for Compact FieldPoint and FieldPoint

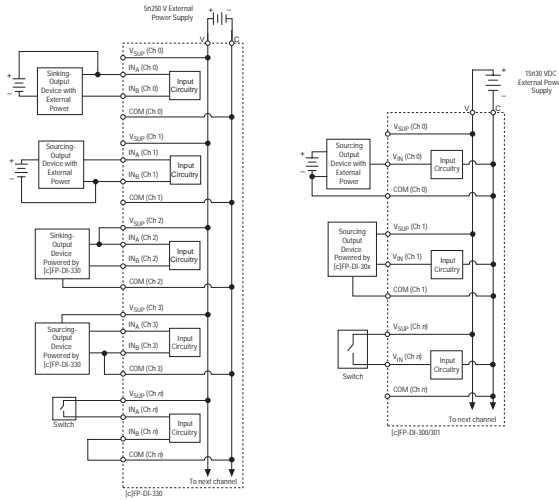

Wiring Schematics for the DI-3xx Modules

## Ordering Information

### Compact FieldPoint

NI cFP-DI-300 .....	777318-300
NI cFP-DI-301 .....	777318-301
NI cFP-DI-330 .....	777318-330

### Recommended Compact FieldPoint System Products

NI cFP-2020 .....	777317-2020
NI cFP-BP-4 .....	778617-04
NI cFP-CB-1 .....	779618-01
NI PS-5 Power Supply .....	778805-90
NI Developer Suite Professional Control Edition .....	777906-03

### FieldPoint

NI FP-DI-300 .....	777518-300
NI FP-DI-301 .....	777518-301
NI FP-DI-330 .....	777518-330

### Recommended FieldPoint System Products

NI FP-1601 .....	777792-01
NI FP-TB-1 .....	777519-01
NI PS-4 Power Supply .....	778586-90
NI Developer Suite Control Edition .....	777905-03

## BUY ONLINE!

Visit [ni.com/info](http://ni.com/info) and enter *cfpdi300*, *cfpdi301*, *cfpdi330*, *fpdi300*, *fpdi301*, and/or *fpdi330*.

## Specifications

Typical for -40 to 70 °C unless otherwise noted.

### Digital Input Channels

[c]FP-DI-300, [c]FP-DI-330 .....	8
[c]FP-DI-301 .....	16

### Input Characteristics

Input impedance ([c]FP-DI-300, [c]FP-DI-301) .....	5 kΩ
Input current limiting ([c]FP-DI-330) .....	1.5 mA

### Isolation Voltage

Maximum isolation voltage	
([c]FP-DI-330 only) .....	250 V <sub>rms</sub> , Installation Category II
Channel-to-channel isolation .....	No isolation between channels
Transient overvoltage .....	2,300 V <sub>rms</sub>

### Physical Characteristics

LED Indicators	
POWER (green) .....	Power on and self-test passed
READY (green) .....	Module configured and ready
<0..15> or <0..7> (green) .....	Input state of each channel
Dimensions (FP only, including terminal base) .....	10.7 by 10.9 by 9.1 cm (4.2 by 4.3 by 3.6 in.)
Weight	
FP-DI-300/301 .....	130 g (4.6 oz)
cFP-DI-300/301 .....	100 g (3.6 oz)
FP-DI-330 .....	133 g (4.7 oz)
cFP-DI-330 .....	103 g (3.7 oz)

### Power Requirements (from Network Module)

[c]FP-DI-300 .....	185 mW
[c]FP-DI-301 .....	325 mW
[c]FP-DI-330 .....	200 mW

### Environment

Operating temperature .....	-40 to 70 °C
Storage temperature .....	-55 to 85 °C
Relative humidity .....	10 to 90%, noncondensing

### Shock and Vibration

These specifications apply only to Compact FieldPoint. NI recommends Compact FieldPoint if your application is subject to shock and vibration.

Operating vibration, random	
(IEC 60068-2-64) .....	10 to 500 Hz, 5 g <sub>rms</sub>
Operating vibration, sinusoidal	
(IEC 60068-2-6) .....	10 to 500 Hz, 5 g
Operating shock	
(IEC 60068-2-27) .....	50 g, 3 ms half sine, 18 shocks at 6 orientations; 30 g, 11 ms half sine, 18 shocks at 6 orientations

### Safety

This product is designed to meet the requirements of the following standards of safety for electrical equipment for measurement, control, and laboratory use:

- IEC 61010-1, EN 61010-1
- UL 3121-1, UL 61010C-1
- CAN/CSA C22.2 No. 1010.1

For UL, hazardous location, and other safety certifications, refer to the product label or to [ni.com](http://ni.com)

### Electromagnetic Compatibility

CE, C-Tick, and FCC Part 15 (Class A) Compliant	
Emissions .....	EN 55011 Class A at 10 m FCC Part 15A above 1 GHz
Immunity .....	EN 61326:1997 + A2:2001, Table 1

For EMC compliance, operate this device with shielded cabling.

### CE Compliance

This product meets the essential requirements of applicable European Directives, as amended for CE Marking, as follows:

Low-Voltage Directive (safety) .....	73/23/EEC
Electromagnetic Compatibility Directive (EMC) .....	89/336/EEC

Refer to the Declaration of Conformity (DoC) for this product for any additional regulatory compliance information. To obtain the DoC for this product, visit [ni.com/hardref.nsf/](http://ni.com/hardref.nsf/) and search by model number or product line.