

# Thermocouple and RTD Modules for Compact FieldPoint and FieldPoint

NEW

## NI [c]FP-TC-120, NI [c]FP-RTD-122, NI [c]FP-RTD-124

- 8 temperature inputs
  - Thermocouple or millivolt
  - 2, 3, or 4-wire RTD inputs
- Built-in signal conditioning
  - 50 and 60 Hz noise rejection
- 16-bit resolution
- Input ranges software configurable per channel
- 2,300 V<sub>rms</sub> bank isolation for transient overvoltage protection
- Hot-swappable with autoconfiguration
- -40 to 70 °C operating range



Module	Input Channels	Resolution	Input Type	Input Ranges (Software Configurable per Channel)	50/60 Hz Noise Filter	All-Channel Update Rate
[c]FP-TC-120	8	16 bits	Thermocouple Millivolt	J, K, T, N, R, S, W, B ±25 mV, ±50 mV, ±100 mV, -20 to 80 mV	✓	0.88 Hz
[c]FP-TC-122	8	16 bits	2, 3 wire-RTD Resistance	Pt 100, Pt 1,000 0 to 400, 0 to 4,000 Ω	✓	0.93 Hz
[c]FP-TC-124	8	16 bits	2, 4 wire-RTD Resistance	Pt 100 0 to 400 Ω	✓	0.93 Hz

## Overview

The National Instruments [c]FP-TC-120 and [c]FP-RTD-12x devices are versatile temperature input modules for Compact FieldPoint and FieldPoint that can be used to measure thermocouples, millivolt level voltages, and 2, 3, and 4-wire RTDs in applications like temperature chamber control, device testing, and process control. Thermocouple sensors are low cost and flexible temperature devices. RTD sensors are used in applications where you need to acquire temperatures with high accuracy. Two and 3-wire RTDs work well for applications with short signal wires and low noise levels, 4-wire RTDs are well suited for applications with long signal wires or high noise levels. All these I/O modules include overranging and onboard diagnostics to ensure trouble-free installation and maintenance. The modules will both measure and linearize signals on-board to return scaled values to your control or monitoring software. NI TC-120 and RTD-12x modules come with NIST-traceable calibration certificates, ensuring accurate and reliable analog measurements.

## Compact FieldPoint and FieldPoint

These modules are available for both FieldPoint and Compact FieldPoint, with identical measurement specifications, functionality, and accuracy. Compact FieldPoint is designed for industrial control applications that perform advanced embedded control, data logging, headless operation, and Ethernet connectivity. Compact FieldPoint, our most rugged and reliable platform, is designed for industrial and mobile

environments with high shock, vibration, and temperature extremes. FieldPoint is a lower-cost distributed I/O system with a variety of communication options in addition to Ethernet. It is designed to be mounted on DIN rails in static applications where the FieldPoint bank is connected to a PC for data collection, analysis, display, and storage.

## Smart I/O Modules

With Compact FieldPoint and FieldPoint temperature input modules, you can connect directly to industrial sensors or units under test and get high-accuracy measurements. The modules filter, calibrate, and scale raw sensor signals to engineering units, as well as performing self-diagnostics to look for problems with the module or the wiring such as open thermocouples. With the temperature input modules, your software application reads a linearized, calibrated, and scaled value from the I/O module, eliminating the error-prone step of converting binary values to temperature. For increased accuracy and noise rejection, the temperature modules use a 16-bit delta-sigma ADC with an integrated lowpass filter on each channel, which is configured for 50 and 60 Hz rejection. With high-accuracy 16-bit delta-sigma ADCs on the I/O modules, you also get instrument-quality measurements on an industrially rugged, distributed, embedded system.

The temperature input family of modules offers a variety of different update rates to fit your application, ranging from 0.88 to 0.93 Hz. Overall data throughput depends on software loop speeds and network speeds.

# Thermocouple and RTD Modules for Compact FieldPoint and FieldPoint

## [c]FP-TC-120

The [c]FP-TC-120 includes eight differential inputs for thermocouples. It also provides cold-junction compensation using a thermistor embedded in the terminal base or connector block. An onboard microcontroller compensates and linearizes the thermocouple reading to the NIST-90 standard, using an advanced linearization routine for maximum accuracy.

## [c]FP-RTD-122

The [c]FP-RTD-122 includes eight inputs for 2 and 3-wire RTDs. The module uses a stable current source for sensor excitation and an onboard microcontroller that linearizes and scales the measurements to temperature units. You can configure each channel of the modules to return data scaled to temperature (°C, °F, or °K) or resistance. The 3-wire configuration used with the [c]FP-RTD-122 eliminates errors caused by lead wire resistance but will not reduce errors caused by noise. If your application involves high signal noise or long wires, you should use a 4-wire RTD with the RTD-124 module.

## [c]FP-RTD-124

The [c]FP-RTD-124 includes eight inputs for 2 and 4-wire RTDs. The module uses a stable current source for sensor excitation and an onboard microcontroller that linearizes and scales the measurements to temperature units. You can configure each channel of the modules to return data scaled to temperature (°C, °F, or K) or resistance. If your application involves long signal wires or high signal noise, you should use a 4-wire RTD with the RTD-124 module. The 4-wire configuration used with the [c]FP-RTD-124 eliminates voltage drop due to lead wire resistance and reduces errors caused by noise.

## Isolation

The TC-120 and RTD-12x modules feature optical bank isolation with 2,300 V<sub>rms</sub> of breakdown isolation. In addition, the [c]FP-TC-120 and [c]FP-RTD-122 provide double insulation for up to 250 V<sub>rms</sub> of operational isolation. Compact FieldPoint can safely be used in applications where hazardous voltages are present with the cFP-CB-1 or cFP-CB-3 connector block. FieldPoint can safely be used in applications where hazardous voltages are present with the FP-TB-x terminal base. These Compact FieldPoint and FieldPoint modules do not have channel-to-channel isolation.

## Isothermal Connectivity for the [c]FP-TC-120

For maximum accuracy, we recommend using an isothermal connector block or terminal base with the [c]FP-TC-120.

**Compact FieldPoint** – The cFP-CB-3 isothermal connector block minimizes the temperature gradient across wiring connections, improving the accuracy of the cold-junction measurement, and therefore, the thermocouple measurement.

**FieldPoint** – The FP-TB-3 isothermal terminal base minimizes the temperature gradient across the wiring connections, improving

the accuracy of the cold-junction measurement, and therefore, the thermocouple measurement.

## Field I/O Connections

Compact FieldPoint and FieldPoint modules include a built-in power distribution bus that provides multiple power connections on the module. A field-wired power supply connected to the voltage (V) and common (C) terminals is internally connected to a power distribution bus that provides additional breakout terminals for voltage supply (V<sub>SUP</sub>) and common (COM). These terminals provide a convenient way to distribute power to field devices that require external power.

Each input channel on the TC-120 has two terminals for differential input:

1. Thermocouple positive input (IN+)
2. Thermocouple negative input (IN-)

Each input channel on the RTD-122 has three terminals:

1. Excitation output (EXCITE+)
2. Sensing input (SENSE)
3. Common input (COM)

Each input channel on the RTD-124 has four terminals:

1. Excitation output (EXCITE+)
2. Positive sensing input (SENSE+)
3. Negative sensing input (SENSE-)
4. Common input (COM)

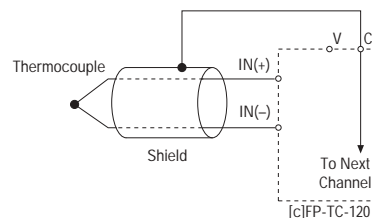
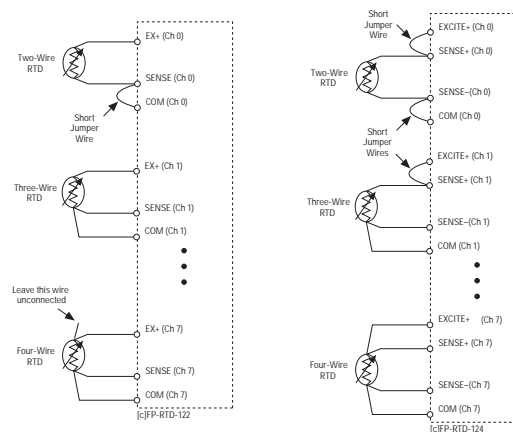

Figure 1. Wiring Schematic for RTD and TC Module

# Thermocouple and RTD Modules for Compact FieldPoint and FieldPoint

## Ordering Information

### Compact FieldPoint

NI cFP-TC-120 .....	777318-120
NI cFP-RTD-122 .....	777318-122
NI cFP-RTD-124 .....	777318-124

### Recommended Compact FieldPoint System Products

NI cFP-2020.....	777317-2020
NI cFP-BP-4.....	778617-04
NI cFP-CB-1.....	778618-01
NI cFP-CB-3.....	778618-03
NI PS-5 Power Supply .....	778805-90
NI Developer Suite Professional Control Edition.....	777906-03

### FieldPoint

NI FP-TC-120.....	777518-120
NI FP-RTD-122.....	777518-122
NI FP-RTD-124.....	777518-124

### Recommended FieldPoint System Products

NI FP-1601 .....	777792-01
NI FP-TB-1.....	777519-01
NI FP-TB-3.....	777519-03
NI PS-4 Power Supply .....	778586-90
NI Developer Suite Control Edition.....	777905-03

## BUY ONLINE!

Visit [ni.com/info](http://ni.com/info) and enter *cfptc120*, *cfprtd122*, *cfprtd124*, *fpct120*, *fprtd122*, and/or *fprtd124*.

## Specifications

Typical for -40 to 70 °C unless otherwise noted.

### Input Characteristics

Number of inputs .....	8
ADC resolution .....	16 bits, 1 in 65,536
Type of ADC.....	Delta-sigma
Filters .....	50/60 Hz rejection
Excitation current	
[c]FP-RTD-122 .....	0.25 mA
[c]FP-RTD-124 .....	2 mA
Data scaling options	
[c]FP-TC-120.....	Temperature (°C, °F, °K) or mV
[c]FP-RTD-122/124.....	Temperature (°C, °F, °K) or resistance (Ω)
Update period, all channels	
[c]FP-TC-120.....	1.13 s
[c]FP-RTD-122/124.....	1.08 s
Signal input bandwidth.....	3 Hz
Cold-junction accuracy ([c]FP-TC-120 with FP-TB-3 terminal base or cFP-CB-3 connector block) .....	0.25 °C typ, 0.5 °C max
Input impedance ([c]FP-TC-120) .....	20 MΩ
Input current ([c]FP-TC-120).....	35 nA typ, 140 nA max
Input noise.....	±1 LSB <sub>FP</sub>
Oversvoltage protection ([c]FP-TC-120 only).....	+40 V
Common-mode voltage referenced to isolated ground	
[c]FP-TC-120.....	1 V
[c]FP-RTD-122/124.....	2 V

### Isolation Voltage

Maximum isolation voltage .....	250 V <sub>rms</sub> , Installation Category II ([c]FP-TC-120 only)
Channel-to-channel isolation .....	No isolation between channels
Transient overvoltage.....	2,300 V <sub>rms</sub>

### Physical Characteristics

LED indicators	
POWER (green) .....	Power on and self-test passed
READY (green) .....	Module configured and ready
OPEN TC <0..7> (red) ([c]FP-TC-120 only) .....	Open or broken thermocouple on channel
Dimensions	
(including FP-TB-x terminal base).....	10.7 by 10.9 by 9.1 cm (4.2 by 4.3 by 3.6 in.)
Weight .....	140 g (4.8 oz)

### Power Requirement

Power from network module.....	350 mW
--------------------------------	--------

### Environmental

FieldPoint modules are intended for indoor use only. For outdoor use, they must be mounted inside a sealed enclosure.

Operating temperature.....	-40 to 60 °C
Storage temperature .....	-55 to 85 °C
Relative humidity .....	10 to 90%, noncondensing
Maximum altitude.....	2,000 m; at higher altitudes the isolation voltage ratings must be lowered.
Pollution degree.....	2

### Shock and Vibration

These specifications apply only to Compact FieldPoint. NI recommends Compact FieldPoint if your application is subject to shock and vibration.

Operating vibration, random	
(IEC 60068-2-64) .....	10 to 500 Hz, 5 g <sub>rms</sub>
Operating vibration, sinusoidal	
(IEC 60068-2-6) .....	10 to 500 Hz, 5 g
Operating shock	
(IEC 60068-2-27) .....	50 g, 3 ms half sine, 18 shocks at 6 orientations; 30 g, 11 ms half sine, 18 shocks at 6 orientations

### Safety

This product is designed to meet the requirements of the following standards of safety for electrical equipment for measurement, control, and laboratory use:

- IEC 61010-1, EN 61010-1
- UL 3121-1, UL 61010C-1
- CAN/CSA C22.2 No. 1010.1

For UL, hazardous location, and other safety certifications, refer to the product label or to [ni.com](http://ni.com)

### Electromagnetic Compatibility

CE, C-Tick, and FCC Part 15 (Class A) Compliant	
Emissions.....	EN 55011 Class A at 10 m
FCC Part 15A above 1 GHz	
Immunity.....	EN 61326:1997 +A2:2001, Table 1

For EMC compliance, you must operate this device with shielded cabling.

### CE Compliance

This product meets the essential requirements of applicable European Directives, as amended for CE Marking, as follows:

Low-Voltage Directive (safety).....	73/23/EEC
Electromagnetic Compatibility	
Directive (EMC).....	89/336/EEC

Refer to the Declaration of Conformity (DoC) for this product for any additional regulatory compliance information. To obtain the DoC for this product, visit [ni.com/hardref.nsl/](http://ni.com/hardref.nsl/) and search by model number or product line.