

## Monitoring High-Speed Turbines Using a Computer-Based Scope

by F. Canagallo, and S. Bava, Microtecnica

**The Challenge:** Replacing a high-cost spectrum analyzer used for real-time monitoring of vibration and axis eccentricity on an E.C.S. production turbine.

**The Solution:** Developing a low-cost system using a computer-based instrument controlled by LabVIEW.

Microtecnica, a manufacturer of environmental control systems and actuation systems for civil and military aircraft, records test parameters that include air cycle machine (turbine) vibration peaks and axis displacement (eccentricity). Accuracy is of great importance when recording these parameters.

After maintenance costs proved unacceptable, we decided to replace a dedicated stand-alone spectrum analyzer with two channels at 100 kHz bandwidth. We developed an automated test stand using the NI 5102 – a computer-based oscilloscope for the ISA bus – and LabVIEW, both from National Instruments. The new system is built on a Windows-based PC. We derive the two analog inputs using an accelerometer with a preamplifier, a proximity sensor with signal conditioning, and two shielded, coaxial cables for interconnection and noise reduction.

### Using the System

In the test data acquisition program, the user selects the turbine under test type. To obtain data from a previous test, the user can request to retrieve logged data.

The program contains a While loop, which has several Case structures to activate selection, such as calibration, cursor, stop acquisition, continuous mode or maximum peak average mode, pause, and clear. LabVIEW simultaneously controls the two data acquisition channels of the NI 5102. Channel A acquires the acceleration signal from the accelerometer installed on the turbine housing, while Channel B acquires the shaft eccentricity from the proximity probe placed on the turbine fan outlet cone.

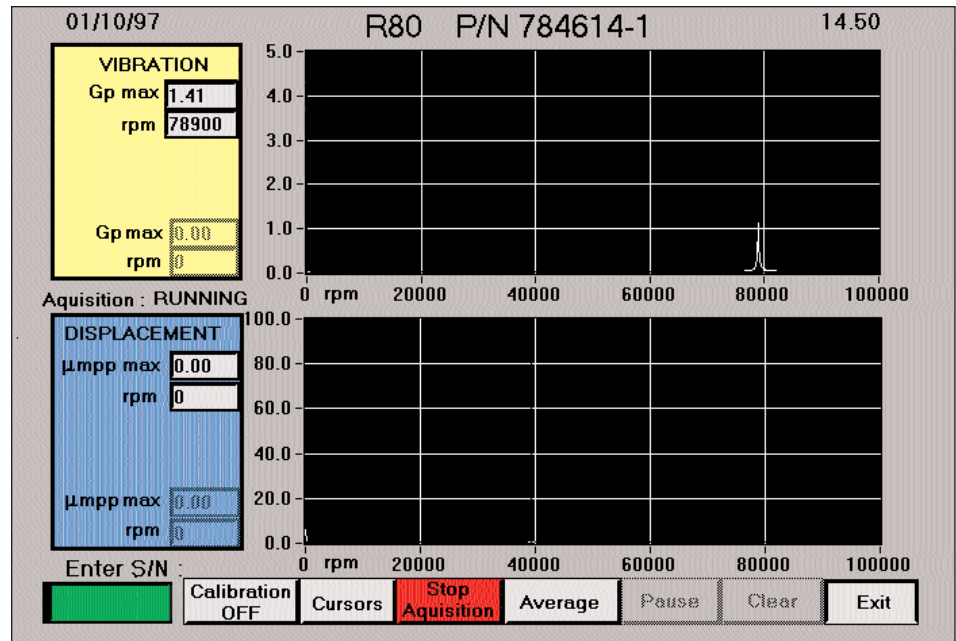

The front panel provides two separate graphs of amplitude spectra.

The instrument front panel provides two separate graphs of amplitude spectra. One graph shows g peak while the other shows micrometers – peak-to-peak versus turbine shaft speed in revolutions per minute. Maximum values of relevant speed are displayed.

*With our computer-based instrument approach, we receive optimum quality through improved accuracy.*

In calibration mode, the user can input a known signal from an external shaker or block gauge calibrator to adjust the available offsets, if necessary. In average mode, the user can acquire spectra with a maximum peak that occurs during the run using shift registers, index arrays, and the properly connected For loop.

The power spectrum recalculation is another important feature that is implemented as a subVI. The spectrum is used to minimize the spectra leaks caused by turbine shaft speed changes. By computing the root sum square (RSS) among a specified number of lines, the user can place the results at the index where the maximum value occurred. When the

acquisition stops, the saved file is identified with the turbine part number and serial number. Thus, to retrieve data on previously tested units, the user can reload the proper file and print out the appropriate graphs and information.

### Results of Our Computer-Based System

Including the scope and sensor installation, it took only two weeks to release the final version of the program to test personnel. Personnel have been favorably impressed with the flexibility of the modifications. With our computer-based instrument approach, we receive optimum quality through improved accuracy. The new system eliminates the spectrum analyzer setting and avoids accidental switch pressing on the instrument front panel that affects correct data acquisition. ▶

**For more information, contact F. Canagallo or S. Bava, Microtecnica, 10126 Turin, Italy, tel (39) 11 6932258/2031, fax (39) 11 6932268.**

Visit [www.natinst.com/instruments](http://www.natinst.com/instruments)

## High-Voltage Solutions Meet Your Application Needs

Many DAQ devices only accept signal levels between  $\pm 10$  V. However, your application may require a DAQ system to handle signal levels well outside of this voltage range.

Therefore, National Instruments offers a wide variety of high-voltage, computer-based measurement solutions. The system you choose depends on your application signal range, speed, channel count, and budget.

### $\pm 15$ V Input Range Systems

**FieldPoint** – Modular, low-cost distributed I/O data acquisition and control system. FieldPoint is ideal for low-speed, medium-channel count applications acquiring multiple signal types.

**5B Series Modules** – Low-channel count, low-cost, front-end signal conditioning system for plug-in DAQ devices. 5B systems offer isolated signal conditioning for applications that require less than 16 channels and have multiple sensor types.

**4350 Family** – DAQ devices with 24 bits of resolution for low-speed voltage or temperature measurements. The 4350 is a low-cost, single-board solution for less than 16 channels of thermocouples or other voltage signals.

### $\pm 42$ V Input Range Systems

**PCI-4451, PCI-4452** – High-performance, low-channel count, dynamic signal acquisition card for audio and vibration applications.

**NI 4551, NI 4552** – High-performance, low-channel count, dynamic signal analyzer card with onboard processing capabilities for audio and vibration applications.

**PCI-6110E, PCI-6111E** – High-performance E Series multifunction I/O device for general-purpose applications with 5 MHz analog input capabilities.

### $\pm 100$ V Input Range Systems

**SCC** – Low-cost, low-channel count analog and digital signal conditioning front end for E Series DAQ devices. SCC systems are ideal for applications with less than 16 channels, custom connectivity, and multiple sensor types.

### $\pm 250$ V Input Range Systems

**SCXI** – Modular, ruggedized, signal conditioning front-end for plug-in DAQ boards that works with a wide variety of sensor and signal types. SCXI is perfect for medium to high-channel count systems requiring high-speed data acquisition.

**NI 4050, NI 4060** – 5-digit multimeter for DC voltage, true-RMS AC voltage, resistance, and thermocouple measurements. The 4050/4060 is ideal for single-channel, low-speed acquisition systems for general-purpose measurements.

### $\pm 5000$ V Input Range Systems

**NI 5102 (with 1000X probe)** – Dual-channel, 8-bit, 20 MS/s (1 GS/s using random interleaved sampling) oscilloscope. The 5102 with attenuating probe is a low-channel count, high-speed solution for very high-voltage signals. ▶

For more information on these products, request the National Instruments 1999 *Measurement and Automation Catalogue* by checking this box on the reply card.

Visit [www.natinst.com/sigcon](http://www.natinst.com/sigcon) and [www.natinst.com/daq](http://www.natinst.com/daq)

## LabVIEW VIs Offer High-Speed Data Logging

National Instruments now offers a set of LabVIEW example VIs that performs

data streaming at previously unattainable rates. These High-Speed Data-Logging (HSDL) VIs offer data compression for creating smaller data files and achieving even higher logging rates.

The package consists of four fundamental VIs. Also included are two high-level examples, similar to those shipped with LabVIEW, and miscellaneous utility functions. The VIs store data to disk in binary format and provide three levels of compression: none (permissible for 16-bit boards only); loss-less (samples are stored as 12 rather than 16 bits); and lossy (each sample is stored as 8-bits). Lossy compression turns a 12-bit board into an 8-bit board, yielding a remarkable improvement in logging speeds.

To maximize performance in logging

applications, choose SCSI drives with high spin rates (at least 10,000 rpm) and several write heads. Moreover, format the target drive and erase the file table before writing to the drive.

The README.txt file that accompanies the VIs provides a complete list of installation files and procedures related to the HSDL VIs. The file also contains hints for application development, as well as an explanation of the parameters required by the HSDL VIs. To use the HSDL VIs, you need NI-DAQ 6.1 or later, LabVIEW 5.0 or later, and a non-AT-bus E Series DAQ board. You can download the example VIs from [www.natinst.com/daq](http://www.natinst.com/daq) ▶

Visit [www.natinst.com/daq](http://www.natinst.com/daq)

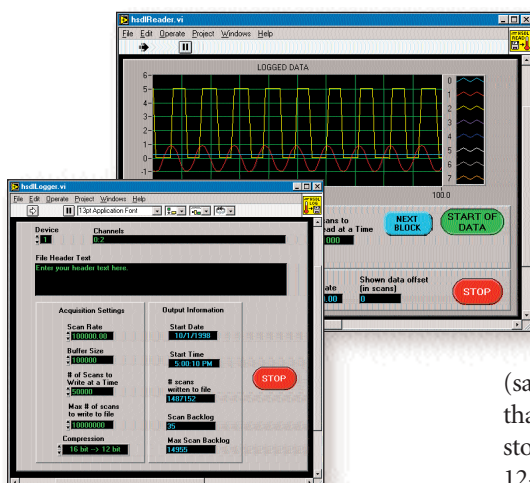

With differing levels of compression available, the LabVIEW example VIs speed up data streaming.

## Separated Ground Planes Keep the Noise Out

To deliver accurate measurements, National Instruments E Series DAQ boards are designed with separated ground planes, which are separate copper grounding sheets located on a circuit board. One copper sheet serves as a ground plane for digital signals, another for analog input, and still another for analog output signals. All digital components and traces, which are used for data and timing, physically reside above or below the digital ground plane and connect directly to the plane for grounding purposes. Likewise, all the analog input and output traces reside above or below their respective analog ground planes and connect to these planes for grounding purposes.

Although the ground planes are separated, the DAQ board must have a single ground reference. This ground is derived from the computer bus ground connection on the bus connector. Because the computer is digital, the grounding point is typically connected to the digital ground plane of the DAQ board. The two analog buses must also connect to this ground. Thus, they bridge the barrier to the digital ground plane at one point each. These bridges are strategically placed, small in area, and have the ability to block noise emanating from the digital circuitry while providing a connection to ground.

### The Benefit of Separated Ground Planes

Separated ground planes reduce noise in a DAQ board by taking advantage of a design common in many A/D and D/A converters. Many converter chips place analog signals on one side of the chip and digital signals on the other. In doing so, the A/D and D/A converter chips take advantage of the separate ground planes by straddling the barrier between them. The digital lines reference the digital ground plane while the analog lines – on the same chip – reference the analog ground plane. Therefore, noise generated on the digital side of the board is

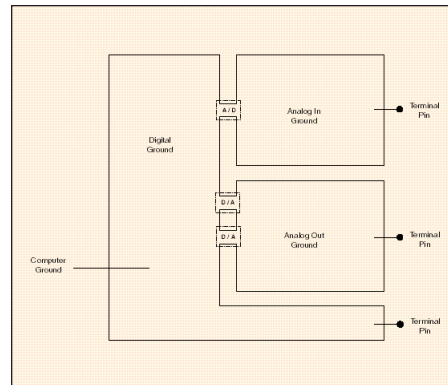

Separate analog input, analog output, and digital ground planes reduce noise on National Instruments DAQ products.

contained to the digital ground plane. The noise does not affect the analog side of the chip or the traces residing around the analog ground plane.

The power that supplies the digital, analog input, and analog output planes are also separated into “power planes.” Typically, power planes mirror the ground planes but reside on a layer separated from the ground planes. Separating the power into individual planes also provides similar benefits.

### Products That Provide Separated Ground Planes

All National Instruments E Series products, and in fact most of our DAQ products, have separated digital and analog ground planes. Our PCI analog output boards also use this technique. You can observe the design by holding the board up to the light; translucent areas are the electrically isolated barriers between ground planes.

To achieve accurate measurements, be sure you ask about separate ground planes before purchasing your DAQ product. ✦

Visit [www.natinst.com/daq](http://www.natinst.com/daq)

## Use Dithering to Increase Accuracy

Dithering refers to the purposeful addition of low-level noise to a signal you want to measure. Considering the time and money spent trying to remove noise from measurement systems, why would you purposefully inject noise into a system? For measurements that are acquired multiple times to be averaged, the injection of the proper kind of noise can effectively enhance the resolution of the analog to digital converter (ADC).

When you perform dithering on National Instruments DAQ products, you add approximately 0.5 LSBrms of white Gaussian noise to the input signal before it is converted by the ADC. Dithering is most useful for applications that perform averaging, such as calibration and

spectral analysis, because it decreases noise modulation and improves differential nonlinearity.

For example, when checking board calibration (a DC measurement) you should enable dithering and average about 1,000 points for a single reading. This approach removes the effects of quantization and reduces measurement noise, resulting in improved resolution.

For high-speed applications that do not involve averaging or spectral analysis, you may want to disable dithering to reduce noise.

The ability to toggle dithering on and off is available on all 12-bit E Series boards – except the simultaneous sampling 611xE family – and all boards in the low-

cost 1200 family. Dithering is not an option for 16-bit E Series boards because the ADC resolution is so fine almost 0.5 LSBrms of noise is produced by the ADC and the input amplifier. That is, the inherent level of noise produced by the board is equivalent to the amount added by dithering.

For National Instruments products that support dithering, you can enable or disable the feature through software. In LabVIEW, use `MIO Config.vi`. In LabWindows/CVI and other environments that call the NI-DAQ library, call `MIO_Config` with the second parameter, `dither`, and set to “0” to disable or “1” to enable dithering. In ComponentWorks, dithering is set using the `ConfigureMIO` method of the `CWDAQTools` control. ✦

## Create Ethernet Measurement Systems Using DAQ Products

**E**thernet is the most common means for connecting remote and distributed computers. As a result, Ethernet is gaining popularity as a platform for remote and distributed measurements. For example, you may need to take a number of I/O points at various locations around your facility or distribute an entire measurement system in multiple locations around the world, yet control them from one central location. With National Instruments DAQ products, you can create these Ethernet measurement systems quickly and easily.

You can control every National Instruments DAQ product remotely via Ethernet. Once a device is installed and configured in a computer connected to a network, you can locate and control that device from any other computer on your network. This solution is ideal when you need to distribute larger channel count systems where high acquisition rates or multiple-instrument types are required. You can control each system from a central computer as if they were configured locally.

National Instruments DAQ products perform at high transfer rates across networks. We have routinely performed continuous acquisitions at 100 kS/s over a local network. The results are impressive, considering that many distributed I/O solutions exhibit rates less than 100 S/s. We have also made remote measurements over the Internet. For example, we configured a computer and DAQ board in Austin, TX, then connected to that computer from Japan via the Internet. Three seconds after requesting a single shot, a 100 kS/s acquisition of 1,000 points, we received the data in Japan.

The same application you create for a local measurement system can work remotely with only one modification – redirect your application to the remote DAQ device. The necessary components for Ethernet communication are included in our driver software so you do not have to learn the intricacies of network communication protocols, thus increasing your productivity when developing remote measurement solutions.✔

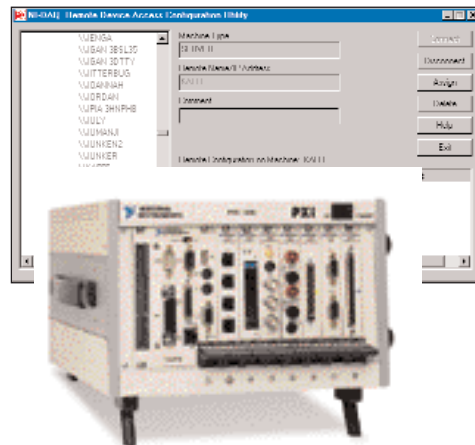

*Using Ethernet, you can control National Instruments DAQ products in remote locations.*

For more information on Ethernet solutions, go to [www.natinst.com/info/news](http://www.natinst.com/info/news) to view the application note.



Visit [www.natinst.com/daq](http://www.natinst.com/daq)

## Measure Thermocouple Temperature Accurately

**M**easuring temperature from thermocouples is one of the most common data acquisition applications across all industries. National Instruments offers a wide variety of solutions for measuring thermocouples.

**SCXI** (SCXI-1100/SCXI-1102/SCXI-1120/SCXI-1121/SCXI-1122) – This high-performance, high-channel count, modular signal conditioning front-end system for plug-in DAQ devices offers a wide variety of thermocouple and other signal conditioning options, and is expandable up to 3,072 channels. With acquisition rates up to 333 kHz, SCXI is a cost-competitive solution for applications that require more than 32 channels while offering additional configurability and flexibility not available on any other platform.

**FieldPoint** (FP-TC-120) and **6B Series** (6B11) – These products offer distributed I/O solutions for low-speed temperature

measurement applications with the flexibility to acquire data from remote locations.

**SCC** (SCC-TC-01/SCC-TC-02) and **5B Series** (5B37/5B47) – These low-channel count signal conditioning front-ends for plug-in DAQ boards offer signal conditioning on a per-channel basis. The 5B Series products offer isolation while the SCC products offer per-channel connectivity.

**AMUX-64T** – A single-board signal conditioning front-end for plug-in DAQ devices, the AMUX-64T is an ideal solution for cost-sensitive, thermocouple-only systems with up to 30 thermocouples.

**NI 4350 Family** – A single-board solution for low-channel count thermocouple systems, the NI-4350s offer 24 bits of resolution and are designed for low-speed temperature measurements.



**VXI** (VXI-SC-1102) – VXI is a high-performance, high-channel count solution for production test applications requiring temperature measurements.✔

For more information on these products, contact National Instruments.

Visit [www.natinst.com/sigcon](http://www.natinst.com/sigcon) and [www.natinst.com/daq](http://www.natinst.com/daq)

# LabWindows/CVI Ensures Production of High-Quality ADSL Modems

by Kjell Olovsson, Wandel & Goltermann

**The Challenge:** Designing an asymmetric digital subscriber line (ADSL) tester to meet the high-volume, multi-unit requirements of telecommunications production testing.

**The Solution:** Wandel & Goltermann uses National Instruments LabWindows/CVI and Test Executive to create an IMPACT ADSL test system, a high-speed, multichannel test system for effectively testing ADSL modem systems.

ADSL is an asymmetrical service that provides up to 9 Mbps of data from the telephone company to the subscriber, and 640 Kbps of data from the subscriber back to the central office. Asymmetrical data is well suited for Internet traffic, where large files and graphics are transmitted downstream to the user and small amounts of data are returned from the user.

ADSL is a digital service that encodes information then transmits it as a digital bit stream. Discrete multi-tone (DMT) is a technique for transmitting ADSL data over 256 discrete channels between 20 kHz and 1.2 MHz.

**After converting to National Instruments products, Wandel & Goltermann now produces a high-speed, user-friendly ADSL tester capable of testing multiple modems simultaneously.**

Further, ADSL is a subscriber line service. Subscriber line refers to the twisted-pair copper wire that runs from a neighborhood telephone cabinet to individual homes and businesses. Because ADSL does not include frequencies below 20 kHz, plain old telephone service (POTS) and ADSL can be transmitted on the same physical pair of wires connected to the home or business.

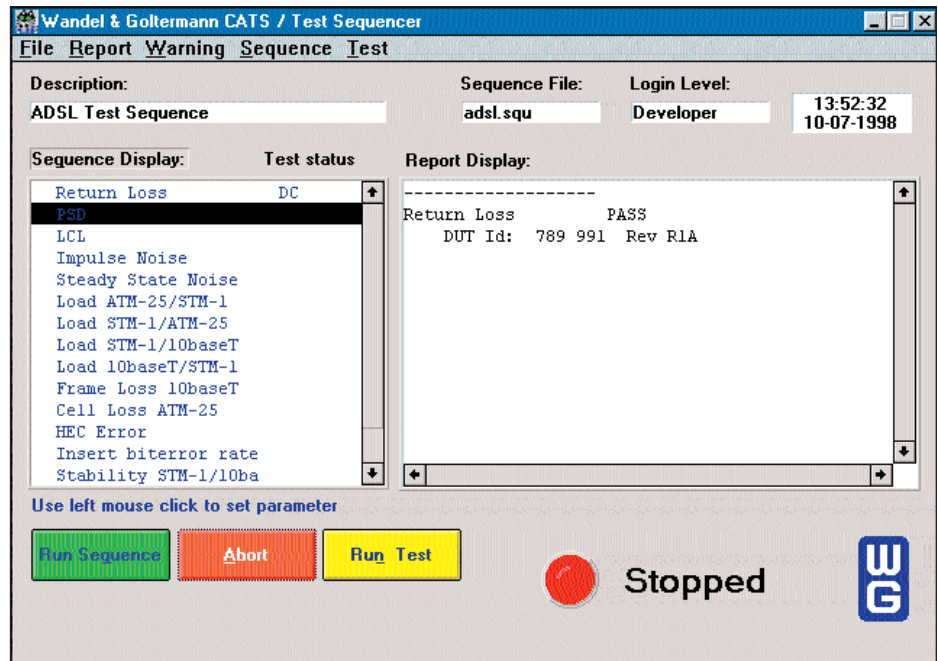

The ADSL tester is capable of simultaneously testing multiple modems.

## Production Testing

Wandel & Goltermann previously used a Unix-based test system with an internally designed controller to test ADSLs. After converting to a National Instruments Test Executive, with LabWindows/CVI and a GPIB controller on Windows, Wandel & Goltermann now produces a high-speed, user-friendly ADSL tester capable of testing multiple modems simultaneously. The IMPACT test system also uses a VXI-based ADSL test head that comprises a physical layer test module, a datacom test module, and an optional POTS module.

Production testing must be performed at both the datacom/backbone interface, located in telephone company central offices, and the copper line interface, connected to homes and businesses. The National Instruments Test Executive manages a suite of high-speed tests, including backbone/datacom and copper line interfaces tests, load and stability tests, as well as return loss, longitudinal conversion loss, and power spectrum density tests.

LabWindows/CVI ensures that the test solution can be configured quickly and optimized to be user friendly. The LabWindows/CVI design makes the IMPACT platform open and facilitates

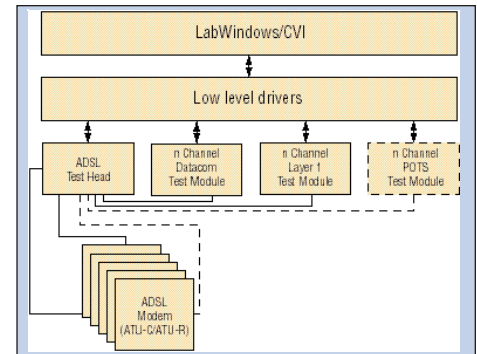

Block diagram of the IMPACT ADSL test solution.

integration of the system into existing test environments. The software integration process can be performed by either Wandel & Goltermann or by users. In either case, the IMPACT platform is easily adapted to customer requirements for high-volume, multi-modem ADSL testing. ▸

**For more information in Europe, contact Kjell Olovsson of Wandel & Goltermann, tel +49 7121-8621-03, e-mail [kjell.olvsson@wago.de](mailto:kjell.olvsson@wago.de); in the U.S., contact Ed Mazza, tel (919) 474-2800, e-mail [ed.mazza@wg.com](mailto:ed.mazza@wg.com)**

Visit [www.natinst.com/cvi](http://www.natinst.com/cvi)

## HS488™ Helps Increase Transient Recorder Data Transfer Rates

by Klaus Lang, Gould Nicolet  
Messtechnik GmbH

**The Challenge:** While transient recorders have improved in performance, the buses used to transfer the data to the computer have not improved.

**The Solution:** Create a transient recorder that uses the TNT4882™ ASIC and the HS488 high-speed GPIB protocol from National Instruments to increase the base transfer rate between the recorder and computer.

Transient recorders are used to perform measurements on short-lived, transient signals at high acquisition rates in a variety of applications, including medicine, automotive, and high-voltage applications.

The measured signals come from tests or experiments that are usually difficult to repeat. Therefore, it is critical to record and save the data correctly each time a test is performed. An example of this type of experiment includes destructive automobile crash tests.

Transient recorders are normally housed in separate units from the PC with their own power supply and memory to eliminate any possible noise interference from the PC. These recorders are connected to the PC via GPIB or another similar interface for data transfer.

Over the past few years, transient recorders have improved in performance. While 8-channel systems running at 1 MHz and 12-bit resolution with 64 KB of memory per channel were top of the class 10 years ago, today 32 or 64 channels with a 10 MHz sampling rate and up to 8 MB of memory per channel are not unusual. Unfortunately, in the same time, the buses used to transfer the data to the computer have not improved significantly in performance. At typical GPIB transfer rates of 300 kbytes/s, transferring 1 Mbytes/s of data from older recorders requires about three seconds, which is acceptable for most applications. However, transferring 256 Mbytes/s from typical recorders, which is required by more modern applications, takes an unacceptable 20 minutes.

### Reducing Transfer Times with HS488

The Gould Nicolet 256XS transient recorder uses the TNT4882 ASIC from National Instruments and the HS488 high-speed GPIB protocol to significantly increase the base transfer rate between the recorder and the computer. When the 256XS is connected to a GPIB plug-in board using the same ASIC, it can achieve transfer rates of 7 Mbytes/s or 3.5 Msamples/s. Using HS488, a complete 256 MB buffer now only requires 35 seconds to transfer. The 256 XS transient recorder and the smaller 256 XE are based on existing systems used worldwide today. They use plug-in modules for input channels, accepting either five or 16 modules with 1, 4, or 8 channels each. This setup gives a maximum of 128 channels per recorder. Configurations of 100 kHz to 10 MHz, 12 to 16-bit, and 64 KB to 16 MB samples memory per channel are also available. The

*The HS488 high-speed GPIB protocol developed by National Instruments increases transfer rates compared to traditional GPIB. The protocol, based on the TNT4882 ASIC, offers significant improvements for continuous data transfer.*

input modules include a variety of signal conditioning options, such as antialiasing filters. Moreover, the instruments can acquire data at four different sampling rates with triggering on each channel. Once the data is acquired, it transfers over GPIB to the PC for analysis, display, and storage.

### Further Increasing the Speed

The 256XS and its software use three other enhancements in addition to HS488 to further increase the effective transfer rate. In the 256XS transient recorder, the interface between the internal memory and the GPIB interface is not based on the standard PC bus; instead, it uses a high-

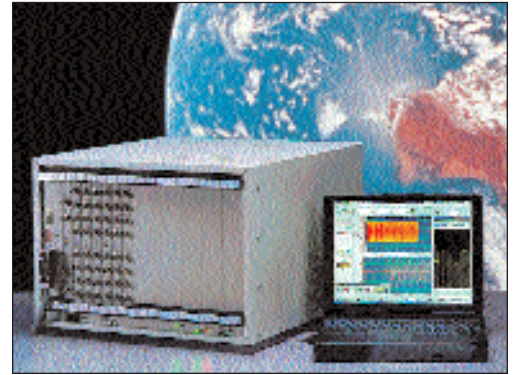

*The Gould Nicolet 256XS transient recorder uses the TNT4882 ASIC and the HS488 high-speed GPIB protocol to significantly increase the base transfer rate between the recorder and the computer.*

speed local bus architecture controlled by an embedded 386EX processor. This significantly increases the transfer rate from the recorder memory to the PC. Secondly, in the 12-bit configuration, the embedded processor uses the complete bandwidth of the bus. Rather than transferring the 12 bits from each sample in two bytes (16-bit) – which wastes 4 bits – as most conventional systems do, the processor combines four samples (4 x 12 bit = 48-bit) in six bytes (6 x 8 bit = 48-bit). By itself, this increases the transfer rate by 25 percent.

When displaying data only on the PC, the data necessary for a proper display is transferred to the PC. For example, the instrument acquires 1 Msample/channel and the PC uses a vertical display resolution of 800 pixels. The resolution is sent to the instrument and the data is reduced to 800 representative min/max data pairs before transfer. The PC displays a complete waveform on the screen. Even when the user zooms in on the display, the new range and necessary data points are automatically calculated and transferred by the instrument. The software always displays the maximum amount of information possible on the screen. The complete data set is transferred only if the data is used for other calculations or further analysis, such as an FFT. However, a large amount of testing, qualification, and tuning of a system is done visually, which offers huge speed increases when changing system

*continued on page 19*

## HS488 Helps Increase Transient Recorder Data Transfer Rates

continued from page 18

parameters and making repeated measurements. In our example, the speed was increased up to 500 times.

### Analysis, Display, and Report Generation

The 256 XS and XE transient recorders include two different software options: Teampro and Proview. The options aid in creating complete test systems including display, analysis, and advanced report generation that the user can combine with Word or Excel. Users can save all system settings, such as instrument configuration, analysis, display, and report generation as separate pieces to form new experiments. Users can predefine specific experiments and run

them in user mode, preventing any changes by other users during setup. Teampro software includes its own API so that users can further extend the functionality of the software. Using easy high-level functions, users can export acquired data, perform manipulations, and re-import the data for display and report generation. With the API, Teampro can act as a turnkey system that provides immediate measurements and results. It can also create fully customized solutions. This development continues the Gould Nicolet vision to provide complete systems, from sensor to report generation, for advanced users. ▶

For more information, contact  
Klaus Lang, Product Manager, Gould Nicolet  
Messtechnik GmbH, Beethoven str. 26, 63526  
Erlensee, Germany, tel +49 6183-9205-0.

Visit [www.natinst.com/hs488](http://www.natinst.com/hs488)

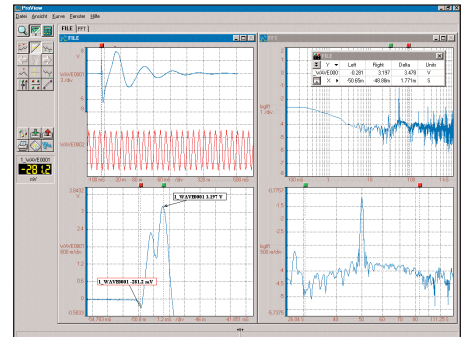

Proview aids in creating complete test systems.

## TECH NOTE

### Worth Reading

- “Developing a LabVIEW-Based, Enterprise-Wide Test Management System,” by John W. Morrissey, User Solutions article, June 1998. **A1054-02**
- “Building a Low-Cost Thermal Imaging System,” by Dino Farina, *Sensors*, June 1998. **A1087-03**
- “Entering the Intelligent Age of Distributed I/O,” by David Potter, *Sensors*, May 1998. **A1196**
- “Automated Testing of the Material Characteristics During the Punching Process,” by Maria Teresa Restivo and Joaquim Gabriel Mendes, User Solutions article, June 1998. **A1318**
- “PC-Based Anti-Lock Braking System Simulation,” by Craig S. Mira, *Evaluation Engineering*, May 1998. **A1323**
- “Lookout Controls a Large Solvent Recovery Plant,” by Vivek Nayak, User Solutions article, July 1998. **A1326**
- “Automated Jet Engine Test System Using VXI Instruments Controlled by LabVIEW,” by David Johnston and Fred Shows, User Solutions article, July 1998. **A1327**
- “LabVIEW 5.0,” by James M. Hansen, *Desktop Engineering*, July 1998. **A1328**
- “LabLRead: IMAQ Vision in Motion,” by Steve McCool, User Solutions article, July 1998. **A1408**
- “Classroom Thermal Conductivity Experiment Using the NI 4350 Temperature Meter and LabVIEW,” by Mike Jagen, User Solutions article, June 1998. **A1412**
- “On-Line Quality Control System for Automobile Stereo Components,” by Peter Wischnewski, Manfred Fochem, and Ralf Hofmeier, User Solutions article, July 1998. **A1413**
- “Using LabWindows/CVI to Integrate a Fast Multitone Audio Analyzer into Industrial Environments,” by Markus Becker, User Solutions article, July 1998. **A1414**
- “An Optical Micrometer for the Nondestructive Evaluation of Micromachined Silicon Sensors,” by Robert A. Ross and Thomas Digges, Jr., User Solutions article, June 1998. **A1416**

## Responding to GPIB Service Requests

**G**PIB Controllers detect and respond to service requests from devices on the bus. The Service Request Line (SRQ) on the GPIB signals the Controller when a service request is pending. Next, the Controller must determine which device is asserted on the SRQ line and respond accordingly. Serial polls are the most common method for SRQ detection and servicing. The application note, titled “Serial Polling and SRQ Servicing with NI-488.2 Software and LabVIEW,” describes how the NI-488.2 software detects and responds to service requests from IEEE 488 devices. In addition, the application note includes code examples that demonstrate how to implement the NI-488.2 software routines and functions in a LabVIEW program. ▶

To view the application note, go to  
[www.natinst.com/info/news](http://www.natinst.com/info/news)



Visit [www.natinst.com/gpib](http://www.natinst.com/gpib)

## PXI Systems Alliance Elects First Officers

On August 28, 1998, the PXI Systems Alliance held its first face-to-face meeting in Austin, TX. The PXI Systems Alliance is a group of more than 40 companies that formed in June of this year to promote and maintain the PXI specification. PXI extends CompactPCI for applications in measurement and automation.

Members of the group held the organizational meeting to elect officers, adopt a set of operating procedures, and plan group activities. Carsten Puls, National Instruments PXI Product Manager, was elected chairperson of the alliance. Darach Kelly, Managing Director of PX Instrument Technology, was elected as Secretary. Mr. Kelly was also elected as co-chairperson of the Marketing Subcommittee and is responsible for European marketing activities. Bob

Stasonis, GENEVA Marketing Manager of Genrad, co-chairs the Marketing Subcommittee and directs North American marketing activities. Mark Wetzel, National Instruments Senior Design Engineer, was elected chairperson of the Technical Subcommittee, which maintains and develops future revisions of the PXI specification. ▶



For more information on the PXI Systems Alliance, go to [www.pxisa.org](http://www.pxisa.org)

Visit [www.natinst.com/pxi](http://www.natinst.com/pxi)

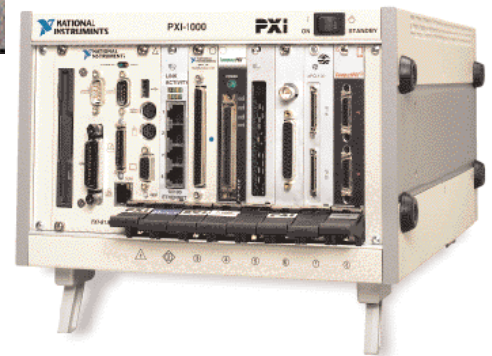

## Stepper Motor Control Introduced to CompactPCI and PXI Systems

National Instruments has introduced a new line of 4-axis PXI stepper control modules. The PXI-7314 open-loop and the PXI-7324 closed-loop controllers are intelligent motion modules that are fully compatible with the CompactPCI specification. These new modules provide the functionality and features necessary to integrate motion control into measurement and automation applications.

The PXI stepper modules can control up to four stepper motors with fully programmable command outputs, driver inhibit/enable signals, and forward, reverse, and home inputs per axis. Accurate trajectory control manages position, velocity, and acceleration with an acceleration boost for enhanced performance. Stepper output pulse rates up to 750 kHz can easily handle full, half and microstepping applications.

The PXI-7324 closed-loop version adds quadrature encoder feedback per axis and facilitates precise motion tracking, position error control, and in-position verification. The PXI stepper control boards feature an onboard 32-bit CPU and embedded real-time control firmware that off-loads the host PC, manages motion tasks, and

integrates digital I/O. The firmware also runs onboard command sequences, including point-to-point motion, 1-4 axis simultaneous control, velocity profiling, and multi-axis linear vector motion control.

The PXI-7314 and PXI-7324 stepper boards join the successful family of ValueMotion™ multi-axis controller boards. They provide general-purpose motion control in ISA, PCI, and PXI/CompactPCI bus configurations. ValueMotion controller boards feature a reliable single cable connection to a rich lineup of universal motion interface (UMI) wiring devices and nuDrive stepper driver units. The nuDrive contains bipolar microstepping drives and integrated DC supplies for motor, encoder, and limit I/O power.

ValueMotion VIs for LabVIEW and BridgeVIEW fully support the PXI-7314 and PXI-7324 stepper modules. ValueMotion VIs implement the entire motion command set API. The VIs also provide functional examples in a powerful toolbox of ready-to-run single and multi-axis control and display panels. The PXI stepper modules also include the following items: pcRunner motion software for Windows NT/98/95 – providing out-of-

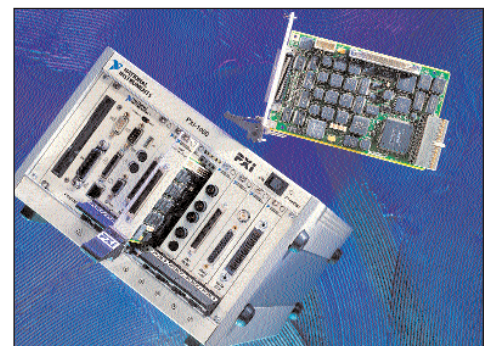

The PXI stepper modules can control up to four stepper motors.

the-box control without any programming; DLLs; a C-callable motion function library; and programming examples. The PXI-7314 and PXI-7324 stepper boards, compatible UMIs, and nuDrives are currently shipping from stock. ▶

For more information on PXI motion control boards, go to [www.natinst.com/info/news](http://www.natinst.com/info/news) to view the PXI-7314/PXI-7324 data sheet.



Visit [www.natinst.com/motion](http://www.natinst.com/motion)

## 1999 National Instruments Catalogue Available Now

The free National Instruments 1999 *Measurement and Automation Catalogue* is a "must-have" reference, featuring more than 800 pages of industry-leading software and hardware products that engineers and scientists use to develop integrated computer-based measurement and automation systems. New product highlights include National

Instruments LabVIEW Version 5.0, tool sets for developing IVI-compliant drivers, and the latest high-speed, high-resolution computer-based instruments. The catalog also describes the new versions of LabWindows/CVI, Lookout, and BridgeVIEW software products, as well as numerous data acquisition products. ➤

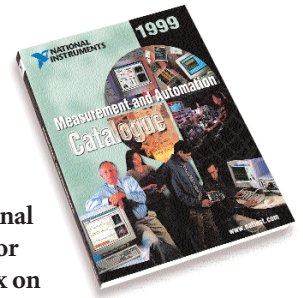

To request copies of the free catalog, contact National Instruments or check this box on the reply card.

## Localized LabVIEW 5.0.1 Success

National Instruments is proud to announce the worldwide success of LabVIEW 5.0.1, now featuring fully localized versions in German, French, and Japanese. Each localized version features translated manuals and reference materials. In addition, the LabVIEW software environment includes localized menus, VI libraries, dialog boxes, and numerous examples to ease development.

Localized versions have been shipping since July 1998, with overwhelming response.



Thousands of users are now taking advantage of developing using LabVIEW in their native languages, speeding and easing their application development. LabVIEW 5.0.1 is available in localized

French, German, and Japanese on Windows development systems. LabVIEW 5.0.1 Japanese is also available on the Mac OS platform. ➤

For more information about LabVIEW 5.0.1, contact your local office.

## Order through the New Online Store

National Instruments now offers select products directly through our Web site at the Online Store. These products include LabVIEW, LabWindows/CVI, ComponentWorks, Measure™, GPIB interfaces, and serial interfaces. Throughout our Web site, we have made special notations near products available in the Online Store. Other National Instruments products will become available in the future.

The Online Store is designed to give customers located in the United States and Canada 24-hour purchasing access to leading computer-based measurement and automation software and hardware products. Using advanced security measures, such as the Secure Electronic Transactions (SET) protocol, we can ensure safe, secure Internet transactions.

Once you place an order, you can check its status by visiting the National Instruments Order Status page, located at

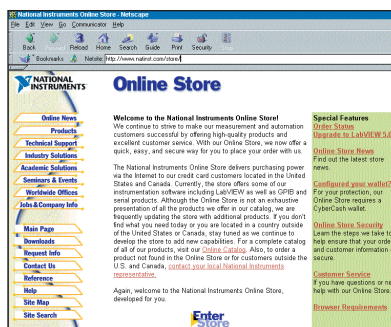

[www.natinst.com/status](http://www.natinst.com/status) In addition, you can access the Price Request System, which supplies prices for National Instruments products in local currencies worldwide. ➤

For more information, send e-mail to [orders@natinst.com](mailto:orders@natinst.com) or visit the Online Store at [www.natinst.com/store](http://www.natinst.com/store)

Visit [www.natinst.com/store](http://www.natinst.com/store)

## Obtain Advice from DAQ Designer™ Online

DAQ Designer Online (DD Online) is a Web-based expert utility that selects the correct hardware and software components for your measurement and automation system.

DD Online asks you a few simple questions about the PC-based measurement system you want to create, including computer specifics, sensor information, and filtering and isolation requirements. Next, DD Online automatically determines which hardware and software components meet your requirements. DD Online also recommends signal conditioning hardware that yields the most accurate measurements at the lowest cost.

After running the DD Online utility, you can either rerun DD Online using another measurement scenario with different requirements or request a price quote from National Instruments for the DD Online-recommended hardware and software components. ➤

For more information about DAQ Designer Online, go to [www.natinst.com/daq](http://www.natinst.com/daq)

Visit [www.natinst.com/daq](http://www.natinst.com/daq)

## New Engine Test Cell Control System

**S**AKOR Technologies, Inc., an Alliance Program member, is offering a powerful, new, full-featured engine test cell control system based on National Instruments DAQ and SCXI or FieldPoint hardware and the LabVIEW 5.0 software environment. DynoLAB III tests the performance, emissions, and component durability critical to the design and certification processes.

With DynoLAB III, the test cell engineer or technician can design and implement complex test protocols without the need to learn a programming language. Interacting with the system using a mouse or touch screen interface, the user can conveniently configure and run the system. The user can define test sequencing, tag channels, perform dynamic calibrations, calculate advanced channels, perform closed-loop control, set sophisticated limits and alarms, log data, generate reports, and remotely monitor

and control the system via phone or Internet connection.

The DynoLAB III modular architecture permits convenient expansion to higher channel counts if required. More demanding test capabilities, including high-speed data acquisition, vibration analysis, and spark and fuel control are accommodated by the DynoLAB III smart instrument interface.

With more than 12 years experience in the test cell market, SAKOR Technologies, Inc., also provides expert test cell integration and technical support services. ▶

**For more information, contact Randal Beattie, SAKOR Technologies, Inc., 2855 W. Jolly Rd., Okemos, MI 48864, tel (517) 332-7256, or e-mail rbeattie@SAKOR.com**

**Visit [www.natinst.com/alliance](http://www.natinst.com/alliance)**

## Testware Uses LabVIEW in Board Test System

**T**estware, a German Alliance Program member, is offering an open board test system based on LabVIEW and National Instruments hardware that is scalable from a MDA to a high-end board test. Designed as a combined in-circuit (ICT) and functional tester, the PT1000 features a 19 in. industrial PC and offers bus extension possibilities with PCI, PXI, VXI, USB, and GPIB.

The basic system offers three PCI bus, five AT bus, and 13 relay matrix slots. Each relay matrix card adds 33 pins. In addition, you can use an AT bus extender to connect to slave chassis that carries up to 19 relay matrix cards.

The PT1000 also features a high-performance fixturing interface made by Virginia Panel, Inc. The PT1000 includes innovative

technologies, such as a 6-wire measurement with guarding technology and a patent-pending sensorless pin check technology. For in-circuit tests, a complete set of LabVIEW VIs covers all of the elements, such as resistors, capacitors, and inductors. For functional tests, you can program the PT1000 with either LabVIEW or LabWindows/CVI. You can then implement the sequence control with National Instruments Test Executive products.

With its unique PC-based implementation using National Instruments hardware and software, the PT1000 is a mixed analog and digital test platform that costs substantially less than traditional board test systems. While cost-effective, it also delivers a flexible, high-performance system. ▶

**For more information, contact Testware (GmbH) Henkestr., 79 D-91052 Erlangen Germany, tel +49 9131-89 82 90, fax +49 9131-89 82 92.**

**Visit [www.natinst.com/alliance](http://www.natinst.com/alliance)**



## Wintek Produces National Instruments-Based POTS Tester

**W**intek, an Italian Alliance Program member, is offering a National Instruments based-POTS tester designed to perform electric measurements on telecommunications terminals, such as telephone sets, answering machines, fax machines, modems, and auxiliary devices. The DTA-2 also uses an artificial head to perform electro-acoustic measurements. The DTA-2 is an open system that you can expand for a wide variety of tests.

With the DTA-2, you can set both the measurement configuration and the values of the involved parameters. In this way, you can perform tests in accordance with all different international standards such as the new European standard ETSI-CTR1. For compliance testing, you can use the DT-2 in full automatic mode and achieve fast, repeatable tests. DTA-2 is a modular system fitted with optional configurations to suit your requirements. This intrinsic versatility makes it an instrument with unlimited application potential, ranging from product certification to research and development to production testing.

The DTA-2 measuring system consists of the DTA-2 instrument, which accounts for hardware configuration and signal measurement, and an input-output interface towards the DAQ board, designed specifically to analyze dynamic signals in audio frequency range. You can develop applications in LabVIEW and/or LabWindows/CVI for signal measurement and creating operator interface systems. The database and statistics functions make it easy to analyze results in all phases, from the design stage, to quality control, to the production line. ▶

**For more information on contact Angelo Pozzi of Wintek S.a.S., Via Donatello, 13, Nerviano, Italy 20014, tel +39 331-3585843, fax +39 331-586578 email: winteka@tin.it**

**Visit [www.natinst.com/alliance](http://www.natinst.com/alliance)**

## Graftek Uses National Instruments IMAQ for Board Inspection

**G**raftek Imaging, Inc., an Alliance Program member, recently introduced a National Instruments-based automated inspection system for manufacturers or volume consumers of circuit boards and electronic components. With pcINSPECT, you can specify inspection operations and acceptance criteria via a graphic interface overlaid on live images of actual components. Inspection operations can include detection of missing or misplaced components, incorrect component presence, defective display indicators or LCD segments, and physical defects in boards or components.

pcINSPECT automatically marks defects and misplaced components on the images of failed boards. pcINSPECT accumulates statistics on failure modes and controls the physical rejection of failed components or boards. You can archive or

selectively transmit images of all or of only failed boards over the Internet. Moreover, pcINSPECT is suitable for manually fixtured, semi-automated, or fully-automated inspection of boards on a conveyor belt system.

pcINSPECT is well suited for circuit board, component, or connector inspection, including component presence and orientation, solder paste application inspection, quality assurance of printed circuit board traces and holes (location and size), detection of substrate chips and flaws, and inspection of lead alignment and coplanarity. Because pcINSPECT is fully integrated with National Instruments IMAQ Vision, LabVIEW, BridgeVIEW, and LabWindows/CVI environments, you can seamlessly combine integrated electrical and functional test procedures with the visual inspection process. ▸

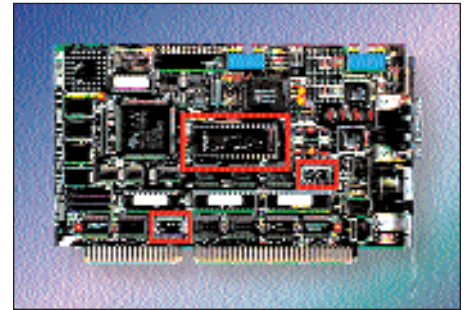

*pcINSPECT automatically marks defects and misplaced components on the images of the boards.*

**For more information, contact Steve McCool, Graftek Imaging, Inc., 1825 Fortview Rd. #109, Austin, TX 78704, tel (512) 416-1099, fax (512) 416-1014, e-mail [graftek@gtk.com](mailto:graftek@gtk.com), or web [www.gtk.com](http://www.gtk.com)**

**Visit [www.natinst.com/alliance](http://www.natinst.com/alliance)**

## IVI Foundation Committed to Developer Success

**T**he IVI Foundation is an organization whose members share a common commitment to test system developer success through open, powerful, instrument control technology. This organization focuses on areas of instrument interchangeability, execution performance, development flexibility, and quality assurance procedures for instrument drivers. The IVI Foundation builds on formal VXI *plug&play* standards to define standard interfaces and models for creating, testing, and executing interchangeable instrument driver functions.

A primary goal of the IVI Foundation is to raise the level of standardization for instrument drivers from basic interoperability to interchangeable instrument classes. By clearly defining APIs for instrument classes, such as oscilloscopes, multimeters, and function generators, you can achieve greater hardware independence. Test program sets that use IVI can be deployed on multiple instrument racks with differing instrumentation, and can be updated as instruments become obsolete; or, you can update them as newer, higher-performance or lower-cost instruments become available. Test developers can

change the hardware on their test systems without changing or recompiling the test program source code. Developers of defense or avionics-related systems, who must follow strict documentation and release procedures when implementing software changes, benefit from this ease of use.

The IVI Foundation identifies instrument classes based on the most common functionality and configurations available in instruments today. Initial classes have been selected based on importance and popularity in common test system configurations. These classes include Oscilloscope (IviScope), Digital Multimeter (IviDmm), Function Generator (IviFGen), Switch (IviSwrch), and Power Supply (IviPower) classes. In the future, additional classes will be identified and defined.

The IVI Foundation works together to define standard instrument programming interfaces. If you would like to get involved in this effort, you can join the IVI Foundation and help define the future of instrument programming. As a Voting Member, you are eligible to be involved in the working groups and vote on the final decisions to define the specifications. As an Associate Member, you can be involved in the

definition efforts, but will not be eligible to vote on final decisions. ▸

**For more information regarding the IVI Foundation Charter or membership, go to [www.ivifoundation.org](http://www.ivifoundation.org)**

### IVI Foundation Members

Advantest Corporation  
Anritsu  
ASCOR  
The Boeing Company  
GEC Marconi  
GenRad, Inc.  
LeCroy  
Lockheed-Martin Aeronautical Systems  
Lucent Technologies  
Marconi North America  
National Instruments  
Northrop Grumman ESSD  
Racal Instruments Inc.  
Raytheon TI Systems (RTTS)  
Rohde & Schwarz  
Tektronix  
Teradyne  
TYX  
Vektrex  
Wavetek

## NIWeek™ 99 Call for Papers

Share your innovative applications of measurement and automation with colleagues from around the world! We encourage you to submit a paper for the NIWeek 99 Best Measurement and

Automation Contest and participate in the Poster Session. NIWeek 99 will be held at the Austin Convention Center, August 18-20, 1999.

All accepted papers will be

published in the Conference Proceedings CD. Winners receive free registration to NIWeek 99, while both winners and semifinalists will present their papers during the conference sessions. A reimbursement of \$100 from the conference fee

will be awarded to one author of each paper accepted (limit one reimbursement per submission).

To enter, e-mail a request to [niweek.contest@natinst.com](mailto:niweek.contest@natinst.com) Abstracts are due by March 1, 1999, with complete paper materials due May 3.✉



### Automated Technical Support

**WWW** .....[www.natinst.com/support](http://www.natinst.com/support)

**FTP Site** .....[ftp.natinst.com](ftp://ftp.natinst.com)  
login – anonymous  
password – your Internet address

**Fax-on-Demand**.....(512) 418-1111

 This newsletter represents a commitment from National Instruments to the environment.

## Trade Shows

Look for the National Instruments booth at these upcoming trade shows:

**COMDEX**  
Las Vegas, NV  
November 16-20

**Embedded Computing Show**

Phoenix, AZ Dec 10

**Photonics** San Jose, CA Jan 26-28

**Nepcon** Anaheim, CA Feb 23-25

**SAE** Detroit, MI March 1-4

**PittCon** Orlando, FL March 8-11

**Industrial Automation**  
Chicago, IL March 15-18

Corporate Headquarters: 11500 N Mopac Expwy, Austin, TX 78759-3504 USA • Tel (512) 794-0100 • Fax (512) 683-8411 • [info@natinst.com](mailto:info@natinst.com) • [www.natinst.com](http://www.natinst.com)

Canadian Sales Offices: P.O. Box 42252 • 128 Queen St. S. • Mississauga, ON L5M 4Z0 • Tel: (905) 785-0085 • Fax (905) 785-0086

1000 Boulevard St. Jean, Suite 316, Pointe-Claire, PQ H9R 5P1 • Tel (514) 694-8521 • Fax (514) 694-4399

Mexico Sales Office: Galileo, 31B, Suite 570, Col. Polanco 11560, Mexico D.F. • Tel 001 800 010 0793

Printed in USA



11500 N Mopac Expwy  
Austin, TX 78759-3504

## NIWeek™ 99 Call for Papers

Share your innovative applications of measurement and automation with colleagues from around the world! We encourage you to submit a paper for the NIWeek 99 Best Measurement and

Automation Contest and participate in the Poster Session. NIWeek 99 will be held at the Austin Convention Center, August 18-20, 1999.

All accepted papers will be

published in the Conference Proceedings CD. Winners receive free registration to NIWeek 99, while both winners and semifinalists will present their papers during the conference sessions. A reimbursement of \$100 from the conference fee

will be awarded to one author of each paper accepted (limit one reimbursement per submission).

To enter, e-mail a request to [niweek.contest@natinst.com](mailto:niweek.contest@natinst.com) Abstracts are due by March 1, 1999, with complete paper materials due May 3.✉



### Automated Technical Support

**WWW** .....[www.natinst.com/support](http://www.natinst.com/support)

**FTP Site** .....[ftp.natinst.com](ftp://ftp.natinst.com)  
login – anonymous  
password – your Internet address

**Fax-on-Demand**.....(512) 418-1111

 This newsletter represents a commitment from National Instruments to the environment.

## Trade Shows

Look for the National Instruments booth at these upcoming trade shows:

**COMDEX**  
Las Vegas, NV  
November 16-20

**Embedded Computing Show**

Phoenix, AZ Dec 10

**Photonics** San Jose, CA Jan 26-28

**Nepcon** Anaheim, CA Feb 23-25

**SAE** Detroit, MI March 1-4

**PittCon** Orlando, FL March 8-11

**Industrial Automation**  
Chicago, IL March 15-18

Corporate Headquarters: 11500 N Mopac Expwy, Austin, TX 78759-3504 USA • Tel (512) 794-0100 • Fax (512) 683-8411 • [info@natinst.com](mailto:info@natinst.com) • [www.natinst.com](http://www.natinst.com)

Canadian Sales Offices: P.O. Box 42252 • 128 Queen St. S. • Mississauga, ON L5M 4Z0 • Tel: (905) 785-0085 • Fax (905) 785-0086

1000 Boulevard St. Jean, Suite 316, Pointe-Claire, PQ H9R 5P1 • Tel (514) 694-8521 • Fax (514) 694-4399

Mexico Sales Office: Galileo, 31B, Suite 570, Col. Polanco 11560, Mexico D.F. • Tel 001 800 010 0793

Printed in USA



11500 N Mopac Expwy  
Austin, TX 78759-3504

Change Service Requested

First-Class Mail  
U.S. POSTAGE  
PAID  
Lancaster, PA  
Permit No. 1349

## NIWeek™ 99 Call for Papers

Share your innovative applications of measurement and automation with colleagues from around the world! We encourage you to submit a paper for the NIWeek 99 Best Measurement and

Automation Contest and participate in the Poster Session. NIWeek 99 will be held at the Austin Convention Center, August 18-20, 1999.

All accepted papers will be

published in the Conference Proceedings CD. Winners receive free registration to NIWeek 99, while both winners and semifinalists will present their papers during the conference sessions. A reimbursement of \$100 from the conference fee

will be awarded to one author of each paper accepted (limit one reimbursement per submission).

To enter, e-mail a request to [niweek.contest@natinst.com](mailto:niweek.contest@natinst.com) Abstracts are due by March 1, 1999, with complete paper materials due May 3.✉



### Automated Technical Support

**WWW** .....[www.natinst.com/support](http://www.natinst.com/support)

**FTP Site** .....[ftp.natinst.com](ftp://ftp.natinst.com)  
login – anonymous  
password – your Internet address

**Fax-on-Demand**.....(512) 418-1111

This newsletter represents a commitment from National Instruments to the environment.

## Trade Shows

Look for the National Instruments booth at these upcoming trade shows:

**COMDEX**  
Las Vegas, NV  
November 16-20

**Embedded Computing Show**

Phoenix, AZ Dec 10

**Photonics** San Jose, CA Jan 26-28

**Nepcon** Anaheim, CA Feb 23-25

**SAE** Detroit, MI March 1-4

**PittCon** Orlando, FL March 8-11

**Industrial Automation**  
Chicago, IL March 15-18

Corporate Headquarters: 11500 N Mopac Expwy, Austin, TX 78759-3504 USA • Tel (512) 794-0100 • Fax (512) 683-8411 • [info@natinst.com](mailto:info@natinst.com) • [www.natinst.com](http://www.natinst.com)

Canadian Sales Offices: P.O. Box 42252 • 128 Queen St. S. • Mississauga, ON L5M 4Z0 • Tel: (905) 785-0085 • Fax (905) 785-0086

1000 Boulevard St. Jean, Suite 316, Pointe-Claire, PQ H9R 5P1 • Tel (514) 694-8521 • Fax (514) 694-4399

Mexico Sales Office: Galileo, 31B, Suite 570, Col. Polanco 11560, Mexico D.F. • Tel 001 800 010 0793

Printed in USA



11500 N Mopac Expwy  
Austin, TX 78759-3504

Change Service Requested

Bulk Rate  
U.S. Postage  
PAID  
Lancaster, PA  
Permit No. 1349

# NIWeek™ 99 Call for Papers

Share your innovative applications of measurement and automation with colleagues from around the world! We encourage you to submit a paper for the NIWeek 99 Best Measurement and

Automation Contest and participate in the Poster Session. NIWeek 99 will be held at the Austin Convention Center, August 18-20, 1999.

All accepted papers will be

published in the Conference Proceedings CD. Winners receive free registration to NIWeek 99, while both winners and semifinalists will present their papers during the conference sessions. A reimbursement of \$100 from the conference fee

will be awarded to one author of each paper accepted (limit one reimbursement per submission).

To enter, e-mail a request to [niweek.contest@natinst.com](mailto:niweek.contest@natinst.com) Abstracts are due by March 1, 1999, with complete paper materials due May 3.✉



## Automated Technical Support

**WWW** ..... [www.natinst.com/support](http://www.natinst.com/support)

**FTP Site** ..... [ftp.natinst.com](ftp://ftp.natinst.com)  
login – anonymous  
password – your Internet address

**Fax-on-Demand** ..... (512) 418-1111

This newsletter represents a commitment from National Instruments to the environment.

## Trade Shows

Look for the National Instruments booth at these upcoming trade shows:

### Elektronik 99

(Sweden)

January 19-22

### Teknik og Data

(Denmark)

February 10-12

### MT Essen 99

(Germany)

February 24-25

**National Instruments Gesellschaft m.b.H.**  
Plainbachstr. 12  
5101 Salzburg-Bergheim  
Tel.: (0662) 45 79 90-0  
Fax: (0662) 45 79 90-19

**National Instruments Belgium NV**  
Leuvensesteenweg 613  
B-1930 Zaventem  
Tel: 02/757.00.20  
405 120 (Luxemburg)  
Fax: 02/757.03.11

**National Instruments Denmark**  
Christianshusvej 189  
2970 Hørsholm  
Tel: 45 76 26 00  
Fax: 45 76 26 02

**National Instruments Finland Oy**  
PL 2, Sinikalliontieg  
02631 Espoo  
Puh: (09) 72572511  
Fax: (09) 72572555

**National Instruments France**  
Centre d'Affaires Paris-Nord  
Immeuble "Le Continental" - BP 217  
93153 Le Blanc-Mesnil CEDEX  
Tel.: (01) 48 14 24 24  
Fax: (01) 48 14 24 14

**National Instruments Germany GmbH**  
Konrad-Celtis-Str. 79  
81369 München  
Tel.: 089/741 31 30  
Fax: 089/714 60 35

**National Instruments Israel Ltd.**  
P.O. Box 184  
Givatayim 53101  
Tel: 03 6120092  
Fax: 03 6120095

**National Instruments Italy S.r.l.**  
Via Anna Kuliscioff, 22  
20152 Milano  
Tel: 02/413091  
Fax: 02/41309215

**Filiale di Roma**  
Via Alvisè Cadamosto, 14  
00154 Roma  
Tel: 06/5745778  
Fax: 06/5745776



### Corporate Headquarters

11500 N Mopac Expwy  
Austin, TX 78759-3504 USA  
Tel: (512) 794-0100  
Fax: (512) 683-8411  
[info@natinst.com](mailto:info@natinst.com)  
[www.natinst.com](http://www.natinst.com)

**National Instruments Netherlands BV**  
Vijzelmolenlaan 8A  
3447 GX Woerden  
Tel: 0348 433466  
Fax: 0348 430673

**National Instruments Norge**  
Industrigt. 15  
Postboks 592  
3412 LIERSTRANDA  
Tel: 32 84 84 00  
Fax: 32 84 86 00

**National Instruments Spain S.L.**  
Europa Empresarial  
C/ Rozabella Nº 6  
Edf. Paris, 2ª Planta, Oficina Nº 6  
28230 Las Rozas, Madrid  
Tel: (91) 640 0085  
(93) 582 0251 (Barcelona)  
Fax: (91) 640 0533

**National Instruments Sweden AB**  
Box 2004  
Råsundavägen 166  
171 02 SOLNA  
Tfn: 08 730 49 70  
Fax: 08 730 43 70

**National Instruments Switzerland**  
Sonnenbergstr 53  
CH-5408 Ennetbaden  
Tel.: 056/200 51 51  
022/980 05 11 (Geneva)  
Fax: 056/200 51 55

**National Instruments Corporation (U.K.) Ltd.**  
21 Kingfisher Court  
Hambridge Road  
Newbury, Berkshire  
RG14 5SJ  
Tel: 01635 523545  
Fax: 01635 523154

## NIWeek™ 99 Call for Papers

Share your innovative applications of measurement and automation with colleagues from around the world! We encourage you to submit a paper for the NIWeek 99 Best Measurement and

Automation Contest and participate in the Poster Session. NIWeek 99 will be held at the Austin Convention Center, August 18-20, 1999.

All accepted papers will be published in the Conference Proceedings CD. Winners receive free registration to NIWeek 99, while both winners and semifinalists will present their papers during the conference sessions. A reimbursement of \$100 from the conference fee will be awarded to one author of each paper accepted (limit one reimbursement per submission).



To enter, e-mail a request to [niweek.contest@natinst.com](mailto:niweek.contest@natinst.com) Abstracts are due by March 1, 1999, with complete paper materials due May 3.✉

### Automated Technical Support

**WWW** .....[www.natinst.com/support](http://www.natinst.com/support)

**FTP Site** .....[ftp.natinst.com](ftp://ftp.natinst.com)  
login – anonymous  
password – your Internet address

**Fax-on-Demand** .....(512) 418-1111

 This newsletter represents a commitment from National Instruments to the environment.

## Trade Shows

Look for the National Instruments booth at these upcoming trade shows:

**NIDays Japan** December 4

**'98 National Test, Instrumentation and Industrial Automation**

(China) December 5-8



**Corporate Headquarters**  
11500 N Mopac Expwy  
Austin, TX 78759-3504 USA  
Tel: (512) 794-0100  
Fax: (512) 683-8411  
[info@natinst.com](mailto:info@natinst.com)  
[www.natinst.com](http://www.natinst.com)

**National Instruments Australia**  
P.O. Box 466  
Ringwood, VIC, 3134  
Tel: (03) 9 879 5166  
Fax: (03) 9 879 6277

**Sydney Office**  
P.O. Box 382  
North Ryde, NSW, 2113  
Tel: (02) 9 874-4100  
Fax: (02) 9 874-4455

**National Instruments Hong Kong**  
Suite 210  
New Commerce Centre  
19 On Sum Street  
Shatin, N.T.  
Tel: 2645 3186  
Fax: 2686 8505

**Nihon National Instruments K.K.**  
Shuwa Shiba Park Bldg. B-5F  
Shibakoen 2-4-1  
Minato-ku  
Tokyo 105  
Tel: (03) 5472-2970  
(06) 390 2195 (Osaka)  
Fax: (03) 5472-2977  
(06) 390 2196 (Osaka)

**National Instruments Korea Limited**  
# 203 Poongsung B/D  
51-12, Banpo4-dong, Seocho-ku,  
Seoul, Korea 137-044  
Tel: (02) 596-7456  
Fax: (02) 596-7455

**National Instruments Singapore (Pte) Ltd**  
8 Jalan Kilang Timor  
#03-03B Kewalram House  
Singapore 159305  
Tel: 2265886  
Fax: 2265887

**National Instruments Taiwan**  
7th FL, NO. 135 Keelung Road, Section 2  
Taipei, Taiwan  
R.O.C.  
Tel: 022377 1200  
Fax: 022737 4644