

## GETTING STARTED GUIDE

# NI 9350

8-Ch 24 V Sinking DI, 8-Ch 24 V Sourcing DO  
SIL3 Capable

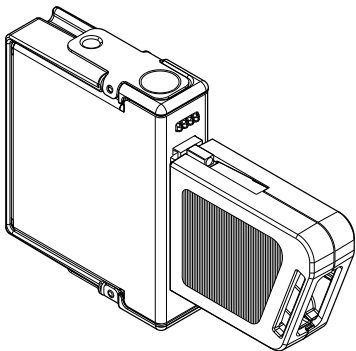

This document explains how to connect to the NI 9350.



**Note** Before you begin, complete the software and hardware installation procedures in your chassis documentation.



**Note** The guidelines in this document are specific to the NI 9350. The other components in the system might not meet the same safety ratings. Refer to the documentation for each component in the system to determine the safety and EMC ratings for the entire system.

## Safety Guidelines

---

Operate the NI 9350 only as described in this document.



**Caution** This icon denotes a caution, which advises you to consult documentation where this symbol is marked.



**Caution** Do not operate the NI 9350 in a manner not specified in this document. Product misuse can result in a hazard. You can compromise the safety protection

built into the product if the product is damaged in any way. If the product is damaged, return it to NI for repair.

## Safety Voltages

Connect only voltages that are within the following limits:



**Caution** Do not connect hazardous voltages to the NI 9350. A hazardous voltage is a voltage greater than 42.4 V peak voltage or 60 V DC to earth ground.

---

### Maximum voltages

---

$V_{\text{sup}}$ -to-COM	30 V DC
DI-to-COM	30 V DC
DO-to-COM	0 V DC to $V_{\text{sup}}$

---



**Caution** DO channels are not protected for negative voltages or voltages greater than  $V_{\text{sup}}$ .

---

### Isolation voltages

---

#### Channel-to-earth<sup>1</sup> (up to 5,000 m)

---

Continuous	60 V DC, Measurement Category I
Withstand	1,000 V RMS, verified by a 5 s dielectric withstand test

---

Measurement Category I is for measurements performed on circuits not directly connected to the electrical distribution system referred to as *MAINS* voltage. *MAINS* is a hazardous live electrical supply system that powers equipment. This category is for measurements of voltages from specially protected secondary circuits. Such voltage measurements include signal levels, special equipment, limited-energy parts of equipment, circuits powered by regulated low-voltage sources, and electronics.

---

<sup>1</sup> Channels include  $V_{\text{sup}}$  and COM.



**Caution** Do not connect the NI 9350 to signals or use for measurements within Measurement Categories II, III, or IV.



**Note** Measurement Categories CAT I and CAT O are equivalent. These test and measurement circuits are for other circuits not intended for direct connection to the MAINS building installations of Measurement Categories CAT II, CAT III, or CAT IV.

## Safety Guidelines for Hazardous Locations

The NI 9350 is suitable for use in Class I, Division 2, Groups A, B, C, D, T4 hazardous locations; Class I, Zone 2, AEx nA IIC T4 Gc and Ex nA IIC T4 Gc hazardous locations; and nonhazardous locations only. Follow these guidelines if you are installing the NI 9350 in a potentially explosive environment. Not following these guidelines may result in serious injury or death.



**Caution** Do not disconnect I/O-side wires or connectors unless power has been switched off or the area is known to be nonhazardous.



**Caution** Do not remove modules unless power has been switched off or the area is known to be nonhazardous.



**Caution** Substitution of components may impair suitability for Class I, Division 2, or Zone 2.



**Caution** The system must be installed in an enclosure certified for the intended hazardous (classified) location, having a tool secured cover/door, where a minimum protection of at least IP54 is provided.

## Special Conditions for Hazardous Locations Use in Europe and Internationally

The NI 9350 has been evaluated as Ex nA IIC T4 Gc equipment under DEMKO 12 ATEX 1202658X and is IECEx UL 14.0089X certified. Each NI 9350 is marked  II 3G and is suitable for use in Zone 2 hazardous locations, in ambient temperatures of  $-40\text{ }^{\circ}\text{C} \leq T_a \leq 70\text{ }^{\circ}\text{C}$ . If you are using the NI 9350 in Gas Group IIC hazardous locations, you must use the device in an NI chassis that has been evaluated as Ex nC IIC T4, Ex IIC T4, Ex nA IIC T4, or Ex nL IIC T4 equipment.



**Caution** Transient protection shall be provided that is set at a level not exceeding 140% of the peak rated voltage value of 85 V at the supply terminals to the equipment.



**Caution** The system shall only be used in an area of not more than Pollution Degree 2, as defined in IEC/EN 60664-1.



**Caution** The system shall be mounted in an ATEX/IECEx-certified enclosure with a minimum ingress protection rating of at least IP54 as defined in IEC/EN 60079-15.



**Caution** The enclosure must have a door or cover accessible only by the use of a tool.

## Electromagnetic Compatibility Guidelines

This product was tested and complies with the regulatory requirements and limits for electromagnetic compatibility (EMC) stated in the product specifications. These requirements and limits provide reasonable protection against harmful interference when the product is operated in the intended operational electromagnetic environment.

This product is intended for use in industrial locations. However, harmful interference may occur in some installations, when the product is connected to a peripheral device or test object, or if the product is used in residential or commercial areas. To minimize interference with radio and television reception and prevent unacceptable performance degradation, install and use this product in strict accordance with the instructions in the product documentation.

Furthermore, any changes or modifications to the product not expressly approved by National Instruments could void your authority to operate it under your local regulatory rules.

## Special Conditions for Marine Applications

Some products are Lloyd's Register (LR) Type Approved for marine (shipboard) applications. To verify Lloyd's Register certification for a product, visit [ni.com/certification](https://www.ni.com/certification) and search for the LR certificate, or look for the Lloyd's Register mark on the product.



**Caution** In order to meet the EMC requirements for marine applications, install the product in a shielded enclosure with shielded and/or filtered power and input/output ports. In addition, take precautions when



designing, selecting, and installing measurement probes and cables to ensure that the desired EMC performance is attained.

## Preparing the Environment

Ensure that the environment in which you are using the NI 9350 meets the following specifications.

Operating temperature (IEC 60068-2-1, IEC 60068-2-2)	-40 °C to 70 °C
---	-----------------

Operating humidity (IEC 60068-2-78)	10% RH to 90% RH, noncondensing
--	------------------------------------

Pollution Degree	2
------------------	---

Maximum altitude	5,000 m
------------------	---------

Indoor use only.



**Note** Refer to the device datasheet on [ni.com/manuals](https://ni.com/manuals) for complete specifications.

# NI 9350 Pinout

---

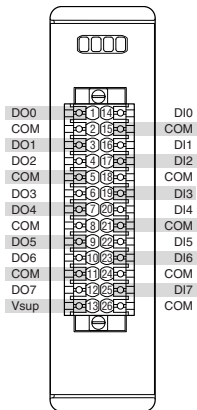

**Table 1.** Signal Descriptions

<b>Signal</b>	<b>Description</b>
COM	Common reference connection
DI	Digital input signal connection
DO	Digital output signal connection
$V_{\text{sup}}$	Voltage supply connection

## NI 9350 LEDs

---



**Table 2. LED Descriptions**

<b>LED</b>	<b>Description</b>
⏻	$V_{sup}$ /Status
0	Internal Fault
1	I/O Fault
2	UserLED0

**Table 3. LED Indicators**

<b>LED</b>	<b>LED Color</b>	<b>LED Pattern</b>	<b>Indication</b>
$V_{\text{sup}}$ /Status	Green	On	Module is powered on. Module is in Operational Mode and User Program is running.
		Flashing	Module powered on. Module is not in Operational Mode or User Program is not running.
		Off	Module is powered off.
Internal Fault	Red	Flashing	Module is in Fail-safe Mode.
		Off	Module is not in Fail-safe Mode.

**Table 3. LED Indicators (Continued)**

LED	LED Color	LED Pattern	Indication
I/O Fault	Red	Flashing	An I/O fault has been detected.
		Off	No I/O Fault has been detected.
UserLED0	Red	On	User-configurable.
		Flashing	
		Off	



**Note** Refer to the C Series Functional Safety Manual on [ni.com/manuals](http://ni.com/manuals) for detailed information on flash patterns in status and fault LEDs.

## Installing the Connector Backshell

---



**Caution** You must use the included connector backshell to secure connections to the NI 9350.

**Figure 1.** Connector Backshell Installation

---

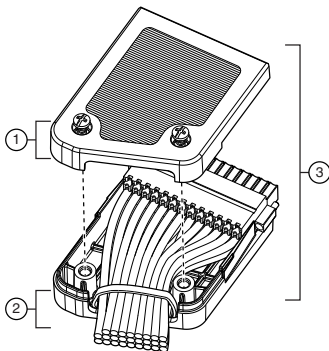

1. Align the connector backshell with the 26-pin spring terminal block.

2. Secure the cable bundle to the connector backshell using a zip tie.
3. Secure the connector backshell using the captive screws. Tighten to  $0.45 \text{ N} \cdot \text{m}$  ( $4 \text{ lb} \cdot \text{in.}$ ) torque.

## Connecting an External Power Supply

---

You must connect an external power supply to the NI 9350. The module is independent from the chassis and requires an external power supply to operate.

Connect the positive lead of the power supply to the supply pin,  $V_{\text{sup}}$ , and the negative lead of the power supply to any common pin, COM.



**Caution** Do not remove or insert modules if the external power supply connected to the  $V_{\text{sup}}$  and COM pins is powered on.

The NI 9350 has current sourcing outputs, meaning the DO pin is driven to  $V_{\text{sup}}$  when the channel is turned on.



# Functional Safety Editor I/O Configurations

---

Refer to the following diagrams to connect the NI 9350 based on the I/O configurations in the Functional Safety Editor. For more information about I/O Configurations, refer to the *C Series Functional Safety Manual* on [ni.com/manuals](http://ni.com/manuals).

## NI 9350 Input Connection

---

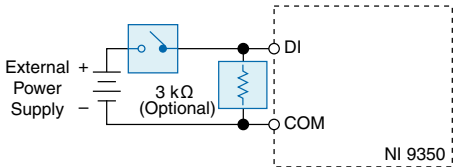

- Use this diagram for single input and dual input configurations.
- Use one of the following pairs for dual switches: DI0 and DI1, DI2 and DI3, DI4 and DI5, or DI6 and DI7.

# NI 9350 Single Input with Test Pulse Connection

---

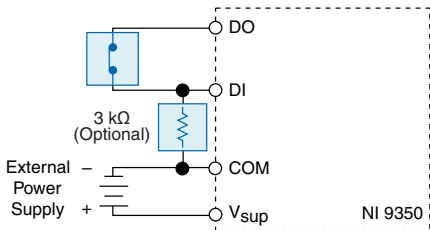

- Use this diagram for single input with test pulse configurations.
- Use test pulses to detect wiring faults on NC switches.
- Connect the DO pin to the NC switch to provide test pulse output.

# NI 9350 Dual Input with Test Pulse Connection

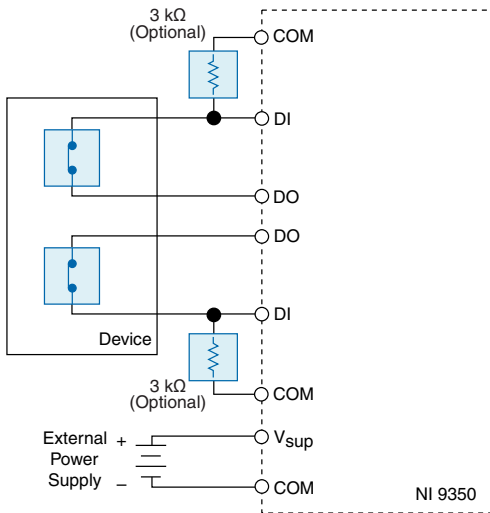

- Use this diagram for dual input with test pulse configurations.
- Use one of the following pairs for dual switches: DI0 and DI1, DI2 and DI3, DI4 and DI5, or DI6 and DI7.
- Use test pulses to detect wiring faults on NC switches.

## NI 9350 Output Connection

---

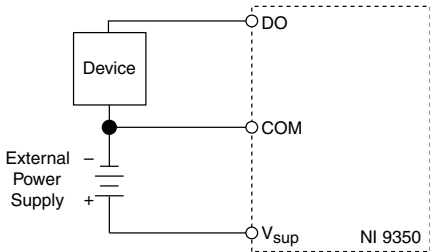

- Use this diagram for the following configurations:
  - Single output
  - Dual output

- Single output with internal test pulse
- Dual output with internal test pulse

## NI 9350 Output with External Test Pulse Connection

---

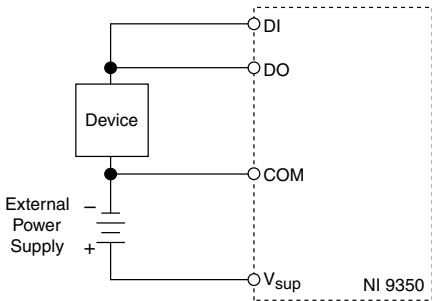

- Use this diagram for single output with external test pulse and dual output with external test pulse configurations.
- Connect a wire from the external monitoring location to a DI channel to monitor the test pulse.
- Connect the DI channel number that corresponds to the DO channel number. Single output with test pulse connections use DOn and DIn. Dual output with test pulse connections use DOn and DIn, DOn+1 and DIn+1.



## NI 9350 Connection Guidelines

---

- Make sure that devices you connect to the NI 9350 are compatible with the module specifications.
- Connect one COM terminal for each DO and each DI connection until all COM terminals are populated. It is acceptable but not preferred to populate COM terminals with jumpers to meet this requirement.
- You must use a two-wire ferrule to create a secure connection when connecting two stranded wires to a single terminal.
- Push a solid wire or ferrule directly into the terminal.
- When inserting a stranded wire without a ferrule, first open the terminal by pressing the push button.
- Verify that all strands of a stranded wire are securely retained.



**Caution** After inserting a wire into a spring terminal, test the connection by gently pulling on the wire to verify that it is securely retained.



## Power Supply

---

Users must use a limited power source (LPS) supply suitable to the safety needs and configuration of the implemented system. NI suggests using one of the following power supply options:

- LPS or NEC Class 2
- SELV or NEC Class 3, 30 V DC maximum, with 6.5 A maximum external fuse

## Pull-Down Resistor

---

- NI recommends connecting an external 3 k $\Omega$  pull-down resistor to each digital input channel in use.
- Resistor power must be rated at minimum to 300 mW at system ambient temperatures. A larger rating can increase reliability.
- A pull-down resistor reduces input signal response times when channels are driven by sourcing outputs.

- The user is responsible for evaluating and choosing the appropriate resistor and terminal block based on the system requirements.
- Follow mounting and thermal guidelines in the CompactRIO controller documentation.

Refer to the table below for suggested terminal blocks for mounting the resistor.

**Table 4.** Third Party Terminal Blocks

Third Party Manufacturer	Series
Phoenix Contact	UTT B
Weidmuller	WTR



**Note** For more information on reducing response times, refer to the *Safety Response Time* section of the *C Series Functional Safety Manual* on [ni.com/manuals](http://ni.com/manuals).

# Protecting the NI 9350 from Flyback Voltages

Install an external flyback diode on any digital output connection to inductive or energy-storing devices that do not have flyback protection. Inductive or energy storing devices include solenoids, motors, and relays.

**Figure 2.** Connecting a Flyback Diode to the NI 9350

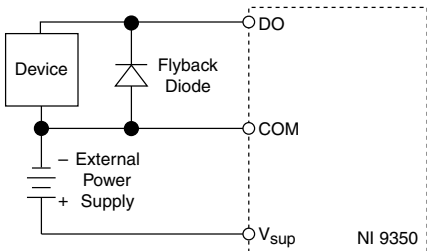

## High-Vibration Application Connections

---

If your application is subject to high vibration, NI recommends that you use ferrules to terminate stranded wire.

You must follow these guidelines to meet the shock and vibration performance specifications stated in the device datasheet on [ni.com/manuals](http://ni.com/manuals).

- Panel mount the system.
- Provide strain relief for the module by securing the cabling to a supporting fixture no more than 8 cm (3 in.) away from the opening of the connector backshell.
- Ensure that the supporting fixture for strain relief is stiff and rigidly coupled to the chassis mounting surface.
- Ensure that you do not directionally bias the module when applying strain relief.

## I/O Protection

---

The NI 9350 provides overcurrent and short-circuit protection for each DO channel.



**Caution** Overvoltage and negative voltage conditions can damage the NI 9350. Check the voltage specifications for all devices that you connect to the NI 9350.



**Caution** Connecting an external power supply to a DO terminal may cause the module to power on. Carefully check all DO and  $V_{sup}$  connections.



**Note** Refer to the device datasheet on [ni.com/manuals](http://ni.com/manuals) for more information about I/O protection ratings.

## Overtemperature Protection

---

The NI 9350 has an internal temperature sensor that will cause the module to enter Fail-safe Mode if the internal temperature limit is exceeded.



**Note** Overtemperature protection will not cause the module to enter Fail-safe Mode under normal operating conditions.

## Where to Go Next

---

For information about deploying a C Series Functional Safety system, refer to the *C Series Functional Safety Manual* on [ni.com/manuals](http://ni.com/manuals).

## Worldwide Support and Services

---

The NI website is your complete resource for technical support. At [ni.com/support](http://ni.com/support), you have access to everything from troubleshooting and application development self-help resources to email and phone assistance from NI Application Engineers.

Visit [ni.com/services](http://ni.com/services) for NI Factory Installation Services, repairs, extended warranty, and other services.

Visit [ni.com/register](http://ni.com/register) to register your NI product. Product registration facilitates technical support and ensures that you receive important information updates from NI.

A Declaration of Conformity (DoC) is our claim of compliance with the Council of the European Communities using the manufacturer's declaration of conformity. This system affords the

user protection for electromagnetic compatibility (EMC) and product safety. You can obtain the DoC for your product by visiting [ni.com/certification](https://ni.com/certification). If your product supports calibration, you can obtain the calibration certificate for your product at [ni.com/calibration](https://ni.com/calibration).

NI corporate headquarters is located at 11500 North Mopac Expressway, Austin, Texas, 78759-3504. NI also has offices located around the world. For telephone support in the United States, create your service request at [ni.com/support](https://ni.com/support) or dial 1 866 ASK MYNI (275 6964). For telephone support outside the United States, visit the *Worldwide Offices* section of [ni.com/niglobal](https://ni.com/niglobal) to access the branch office websites, which provide up-to-date contact information, support phone numbers, email addresses, and current events.

Information is subject to change without notice. Refer to the *NI Trademarks and Logo Guidelines* at [ni.com/trademarks](http://ni.com/trademarks) for information on NI trademarks. Other product and company names mentioned herein are trademarks or trade names of their respective companies. For patents covering NI products/technology, refer to the appropriate location: **Help»Patents** in your software, the `patents.txt` file on your media, or the *National Instruments Patent Notice* at [ni.com/patents](http://ni.com/patents). You can find information about end-user license agreements (EULAs) and third-party legal notices in the readme file for your NI product. Refer to the *Export Compliance Information* at [ni.com/legal/export-compliance](http://ni.com/legal/export-compliance) for the NI global trade compliance policy and how to obtain relevant HTS codes, ECCNs, and other import/export data. NI MAKES NO EXPRESS OR IMPLIED WARRANTIES AS TO THE ACCURACY OF THE INFORMATION CONTAINED HEREIN AND SHALL NOT BE LIABLE FOR ANY ERRORS. U.S. Government Customers: The data contained in this manual was developed at private expense and is subject to the applicable limited rights and restricted data rights as set forth in FAR 52.227-14, DFAR 252.227-7014, and DFAR 252.227-7015.

© 2017 National Instruments. All rights reserved.

377935A-01 July 18, 2017