

# CALIBRATION PROCEDURE

# NI PXI-4132

This document contains information for calibrating the National Instruments PXI-4132 precision source measure unit (SMU). For more information about calibration, visit [ni.com/calibration](http://ni.com/calibration).

## Contents

---

Conventions .....	2
Software Requirements .....	2
Documentation Requirements .....	3
Password .....	3
Calibration Interval .....	3
Test Equipment .....	3
Test Conditions .....	4
Calibration Procedures .....	5
Verification .....	5
Voltage Output Verification .....	6
Current Output Verification .....	7
Voltage Measurement Verification .....	9
Current Measurement Verification .....	10
Load Regulation Verification .....	12
Remote Sense Output Verification .....	14
Adjustment .....	15
Considerations .....	16
Adjusting Voltage Output .....	17
Adjusting Current Output .....	18
Adjusting Voltage Measurement .....	20
Adjusting Current Measurement .....	21
Where to Go for Support .....	23

# Conventions

---

The following conventions are used in this document:

» The » symbol leads you through nested menu items and dialog box options to a final action. The sequence **File»Page Setup»Options** directs you to pull down the **File** menu, select the **Page Setup** item, and select **Options** from the last dialog box.



This icon denotes a note, which alerts you to important information.



When symbol is marked on a product, it denotes a warning advising you to take precautions to avoid electrical shock.



When symbol is marked on a product, it denotes a component that may be hot. Touching this component may result in bodily injury.

**bold** Bold text denotes items that you must select or click in the software, such as menu items and dialog box options. Bold text also denotes parameter names.

*italic* Italic text denotes variables, emphasis, a cross-reference, or an introduction to a key concept. Italic text also denotes text that is a placeholder for a word or value that you must supply.

`monospace` Text in this font denotes text or characters that you should enter from the keyboard, sections of code, programming examples, and syntax examples. This font is also used for the proper names of disk drives, paths, directories, programs, subprograms, subroutines, device names, functions, operations, variables, filenames, and extensions.

*monospace italic* Italic text in this font denotes text that is a placeholder for a word or value that you must supply.

**Platform** Text in this font denotes a specific platform and indicates that the text following it applies only to that platform.

## Software Requirements

---

Calibrating the NI PXI-4132 requires installing NI-DCPower version 1.4 or later on the calibration system. You can download the NI-DCPower instrument driver from the Instrument Driver Network Web site at [ni.com/idnet](http://ni.com/idnet). NI-DCPower supports programming an External Calibration in the C and LabVIEW application development environments (ADEs). When you install NI-DCPower, you only need to install support for the ADE that you intend to use.

LabVIEW support is in the `niDCPower.llb` file, and all calibration VIs are accessible from the NI-DCPower Calibration palette. For LabWindows™/CVI™ users, the NI-DCPower function panel (`niDCPower.fp`) provides access to the calibration functions.

For the locations of files you may need to calibrate your device, refer to the *NI-DCPower Readme*, accessible at **Start»All Programs»National Instruments»NI-DCPower»Documentation»NI-DCPower Readme**.

## Documentation Requirements

---

For information about NI-DCPower and the NI PXI-4132, you can consult the following documents:

- *NI DC Power Supplies and SMUs Getting Started Guide*—provides instructions for installing and configuring NI power supplies and SMUs.
- *NI DC Power Supplies and SMUs Help*—includes detailed information about the NI PXI-4132 and NI-DCPower LabVIEW VI and C function programming references.
- *NI PXI-4132 Specifications*—provides the published specification values for the NI PXI-4132. Refer to the most recent *NI PXI-4132 Specifications* online at [ni.com/manuals](http://ni.com/manuals).

These documents are installed with NI-DCPower. You also can find the latest versions of the documentation at [ni.com/manuals](http://ni.com/manuals).

## Password

---

The default calibration password is `NI`.

## Calibration Interval

---

National Instruments recommends a calibration interval of one year for the NI PXI-4132. You should adjust the recommended calibration interval based on the measurement accuracy demands of your application.

## Test Equipment

---

National Instruments recommends that you use the equipment in Table 1 for calibrating the NI PXI-4132. If you do not have the recommended equipment, select a substitute calibration standard using the minimum requirements listed.

**Table 1.** Recommended Equipment

Equipment	Recommended Model	Parameter Measured	Minimum Requirements
Digital multimeter (DMM)	Agilent 3458A (using at least 7.5 digits)	All parameters	Voltage: better than $\pm 50$ ppm accuracy and better than 500 nV resolution; Current: better than $\pm 75$ ppm accuracy and better than 5 pA resolution
External resistive load	Clarostat 240C	Load regulation	Power resistor decade box with a range of 10 $\Omega$ to 900 k $\Omega$ and a tolerance of $\pm 10\%$ , >1 W
Two 50 $\Omega$ resistors	Vishay PTF5650R000BZEK	Remote sense output	0.1% tolerance, 1/8 W
1 k $\Omega$ resistor	Vishay PTF651K0000BYBF	Remote sense output	0.1% tolerance, 1/8 W

## Test Conditions

Follow these guidelines to optimize the equipment and the environment during calibration:

- Keep connections to the device as short as possible. Long cables and wires act as antennae, picking up extra noise that can affect measurements.
- Verify that all connections to the device, including front panel connections, are secure.
- Ensure that the PXI chassis fan speed is set to HI, that the fan filters are clean, and that the empty slots contain filler panels. For more information, refer to the *Maintain Forced-Air Cooling Note to Users* document available at [ni.com/manuals](http://ni.com/manuals).
- Keep relative humidity between 10% and 70%, noncondensing.
- Allow a warm-up time of at least 30 minutes after the NI-DCPower driver is loaded. Unless manually disabled, the NI-DCPower driver automatically loads with the operating system and enables the device.
- Perform all measurements with the niDCPower Auto Zero property/attribute set to **On** and measurement aperture set to 1 PLC.

- Perform all measurements using **Local Sense** unless otherwise noted.
- Use shielded copper wire for all cable connections to the device. Use twisted-pair wire to eliminate noise and thermal offsets.
- Plug the chassis and the instrument standard into the same power strip to avoid ground loops.

## Calibration Procedures

---

The complete external calibration procedure consists of verifying the performance of the SMU, adjusting calibration coefficients, and verifying performance again after the adjustments. In some cases, a complete calibration procedure may not be required.

### Verification



**Note** Verification must be performed after adjustment to ensure the NI PXI-4132 is operating within the manufacturer's specifications.

This section provides instructions for verifying the NI PXI-4132 specifications.

Verification should be performed under the following conditions:

- niDCPower Auto Zero property/attribute set to **On**
- Measurement aperture set to 1 PLC
- Ambient temperature is  $T_{cal} \pm 5^{\circ}\text{C}$

The NI-DCPower API or Soft Front Panel (SFP) can be used to verify operation of the NI PXI-4132. For additional information on how to use this API refer to the *NI DC Power Supplies and SMUs Help*. The latest version of NI-DCPower can be downloaded at [ni.com/idnet](http://ni.com/idnet).

For example programs that can be used to verify the NI PXI-4132, refer to the example programs installed with NI-DCPower or download example programs at [ni.com/devzone](http://ni.com/devzone).



**Note** Limits in the following tables are based upon the August 2009 edition of the *NI PXI-4132 Specifications*. Refer to the most recent *NI PXI-4132 Specifications* online at [ni.com/manuals](http://ni.com/manuals). If a more recent edition of the specifications is available, recalculate the limits based upon the latest specifications.

## Voltage Output Verification

To verify voltage output, compare a set of requested voltage set points to measurements of the actual voltage at the output by an external DMM. Refer to Figure 1 for the necessary connections.

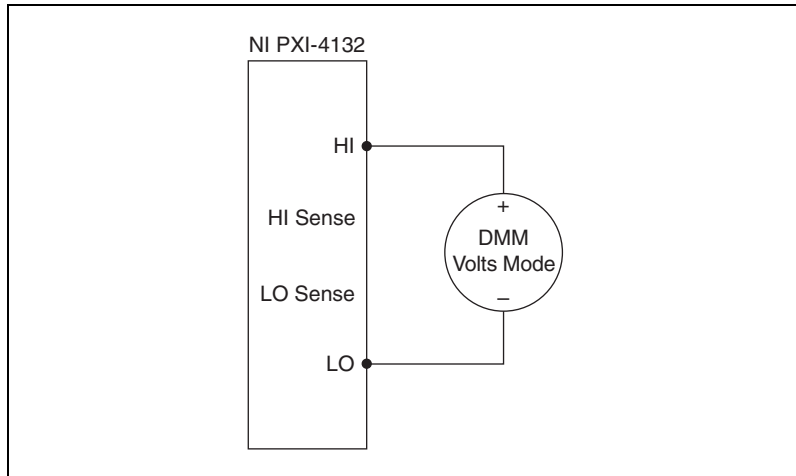

**Figure 1.** Voltage Verification Connection Diagram

Table 2 lists the voltage set points that you must request and measure for each range to complete verification. For example, the 10 V range requires verification at 10 V, 0 V, and -10 V outputs from the NI PXI-4132, taking measurements using the external DMM at each.

To ensure the system has had adequate time to settle, wait one second after requesting a new voltage before taking a measurement with the DMM.

**Table 2.** NI PXI-4132 Voltage Output Verification Points

Range	Test Point	Limits of Accuracy		Measured	
		Lower Limit	Upper Limit	As Found	As Left
10 V	10 V	9.9945 V	10.0055 V		
	0 V	-0.003 V	0.003 V		
	-10 V	-10.0055 V	-9.9945 V		
100 V	100 V	99.965 V	100.035 V		
	75 V	74.97125 V	75.02875 V		
	50 V	49.9775 V	50.0225 V		
	25 V	24.98375 V	25.01625 V		
	0 V	-0.01 V	0.01 V		
	-25 V	-25.01625 V	-24.98375 V		
	-50 V	-50.0225 V	-49.9775 V		
	-75 V	-75.02875 V	-74.97125 V		
-100 V	-100.035 V	-99.965 V			

## Current Output Verification

To verify current output, compare a set of requested current set points to measurements of the actual current at the output by an external DMM. Refer to Figure 2 for the necessary connections.

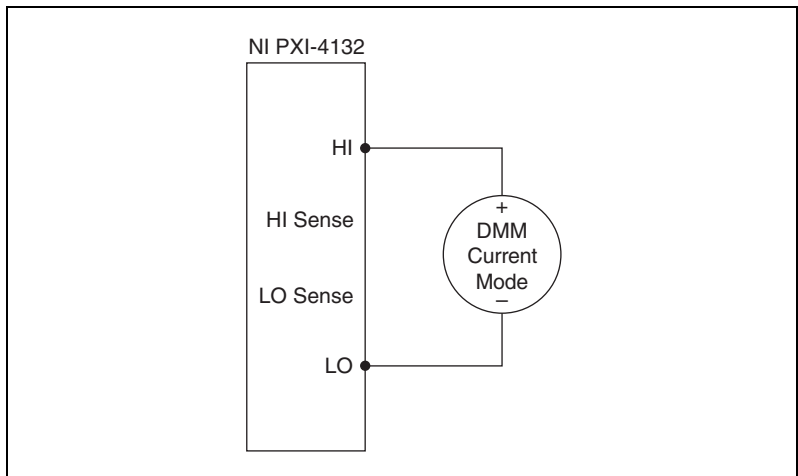

**Figure 2.** Current Verification Connection Diagram

Table 3 lists the current set points that you must request and measure for each range to complete verification. For example, the 10  $\mu\text{A}$  range requires verification at 10  $\mu\text{A}$ , 0.2  $\mu\text{A}$ ,  $-0.2 \mu\text{A}$ , and  $-10 \mu\text{A}$  outputs from the NI PXI-4132, taking measurements using the external DMM at each point.

To ensure the system has had adequate time to settle, wait one second after requesting a new current before taking a measurement with the DMM.

**Table 3.** NI PXI-4132 Current Output Verification Points

Range	Test Point	Limits of Accuracy		Measured	
		Lower Limit	Upper Limit	As Found	As Left
10 mA	10 $\mu\text{A}$	9.9946 $\mu\text{A}$	10.0054 $\mu\text{A}$		
	0.2 $\mu\text{A}$	0.197932 $\mu\text{A}$	0.202068 $\mu\text{A}$		
	$-0.2 \mu\text{A}$	$-0.202068 \mu\text{A}$	$-0.197932 \mu\text{A}$		
	$-10 \mu\text{A}$	$-10.0054 \mu\text{A}$	$-9.9946 \mu\text{A}$		
100 mA	100 $\mu\text{A}$	99.946 $\mu\text{A}$	100.054 $\mu\text{A}$		
	2 $\mu\text{A}$	1.97932 $\mu\text{A}$	2.02068 $\mu\text{A}$		
	$-2 \mu\text{A}$	$-2.02068 \mu\text{A}$	$-1.97932 \mu\text{A}$		
	$-100 \mu\text{A}$	$-100.054 \mu\text{A}$	$-99.946 \mu\text{A}$		
1 mA	1 mA	0.99946 mA	1.00054 mA		
	750 $\mu\text{A}$	0.749545 mA	0.750455 mA		
	500 $\mu\text{A}$	0.49963 mA	0.50037 mA		
	250 $\mu\text{A}$	0.249715 mA	0.250285 mA		
	20 $\mu\text{A}$	0.0197932 mA	0.202068 mA		
	$-20 \mu\text{A}$	$-0.0202068 \text{ mA}$	$-0.0197932 \text{ mA}$		
	$-250 \mu\text{A}$	$-0.250285 \text{ mA}$	$-0.249715 \text{ mA}$		
	$-500 \mu\text{A}$	$-0.50037 \text{ mA}$	$-0.49963 \text{ mA}$		
	$-750 \mu\text{A}$	$-0.750455 \text{ mA}$	$-0.749545 \text{ mA}$		
	$-1 \text{ mA}$	$-1.00054 \text{ mA}$	$-0.99946 \text{ mA}$		

**Table 3.** NI PXI-4132 Current Output Verification Points (Continued)

Range	Test Point	Limits of Accuracy		Measured	
		Lower Limit	Upper Limit	As Found	As Left
10 mA	10 mA	9.9946 mA	10.0054 mA		
	200 $\mu$ A	0.197932 mA	0.202068 mA		
	-200 $\mu$ A	-0.202068 mA	-0.197932 mA		
	-10 mA	-10.0054 mA	-9.9946 mA		
100 mA	100 mA	99.946 mA	100.054 mA		
	2 mA	1.97932 mA	2.02068 mA		
	-2 mA	-2.02068 mA	-1.97932 mA		
	-100 mA	-100.054 mA	-99.946 mA		

## Voltage Measurement Verification

To verify voltage measurement, compare a set of voltage set points as measured by an external DMM to the measured voltage reported by the NI PXI-4132. Refer to Figure 1 for the necessary connections.

Table 4 lists the voltage set points for each range that you must measure and request with both an external DMM and the NI PXI-4132 to complete verification. For example, the 10 V range requires verification at 10 V, 0 V, and -10 V outputs from the NI PXI-4132, taking measurements using the external DMM and NI PXI-4132 at each point.

To ensure the system has had adequate time to settle, wait one second after requesting a new voltage before taking a measurement with the DMM and the NI PXI-4132. The verification limits for voltage measurement will depend on the actual voltage measured with the external DMM, and are expressed as an offset voltage plus percentage of DMM reading in Table 4.

**Table 4.** NI PXI-4132 Voltage Measurement Verification Points

Range	Test Point	Measured Voltage		Test Limit	Reported Voltage	
		As Found	As Left		As Found	As Left
10 V	10 V			0.02%+ 2.0 mV		
	0 V					
	-10 V					
100 V	100 V			0.02%+ 5.0 mV		
	75 V					
	50 V					
	25 V					
	0 V					
	-75 V					
	-50 V					
	-25 V					
-100 V						

## Current Measurement Verification

To verify current measurement, compare a set of current set points as measured by an external DMM to the measured current reported by the NI PXI-4132. Refer to Figure 2 for the necessary connections.

Table 5 lists the current set points for each range that you must measure and request with both an external DMM and the NI PXI-4132 to complete verification. For example, the 10  $\mu$ A range requires verification at 10  $\mu$ A, 0  $\mu$ A, and -10  $\mu$ A outputs from the NI PXI-4132, taking measurements using the external DMM and NI PXI-4132 at each point.

To ensure the system has had adequate time to settle, wait one second after requesting a new current before taking a measurement with the DMM and the NI PXI-4132. The verification limits for current measurement will depend on the actual current measured with the external DMM, and are expressed as an offset current plus percentage of DMM reading in Table 5.



**Note** To verify the zero current test points, instead of using an external DMM, disconnect all external equipment from the I/O connector and take a current measurement with the NI PXI-4132. When you verify the zero current test points this way, the measured current is always zero.

**Table 5.** NI PXI-4132 Current Measurement Verification Points

Range	Test Point	Measured Current		Test Limit	Reported Current	
		As Found	As Left		As Found	As Left
10 mA	10 $\mu$ A			0.028%+ 1.0 nA		
	0 $\mu$ A					
	-10 $\mu$ A					
100 mA	100 $\mu$ A			0.028%+ 10 nA		
	0 $\mu$ A					
	-100 $\mu$ A					
1 mA	1 mA			0.028%+ 0.1 $\mu$ A		
	750 $\mu$ A					
	500 $\mu$ A					
	250 $\mu$ A					
	0 $\mu$ A					
	-250 $\mu$ A					
	-500 $\mu$ A					
	-750 $\mu$ A					
	-1 mA					
10 mA	10 mA			0.028%+ 1 $\mu$ A		
	0 $\mu$ A					
	-10 mA					
100 mA	100 mA			0.020%+ 10 $\mu$ A		
	0 $\mu$ A					
	-100 mA					

## Load Regulation Verification

The load regulation test verifies that the output voltage falls within specified limits when the load current changes or that the output current falls within specified limits when the load voltage changes. For each test, two resistors are needed to vary the load voltage or current. Run this test only after [Voltage Measurement Verification](#) and [Current Measurement Verification](#) has passed.

### Voltage Load Regulation

To verify voltage load regulation, use the NI PXI-4132 in constant voltage mode and confirm the output voltage change falls within calculated limits while varying the load current using different resistors. Table 6 lists the resistance values and measurements needed to complete verification. Refer to Figure 3 for the necessary connections.

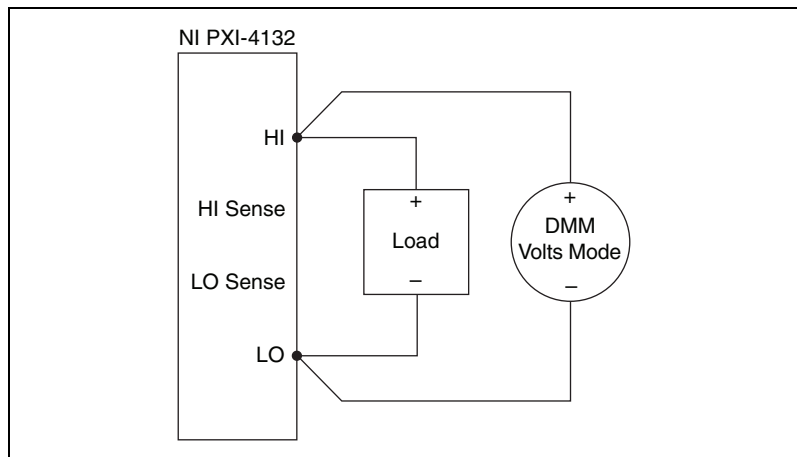

**Figure 3.** Voltage Load Regulation Verification Connection Diagram

Complete the following steps to verify voltage load regulation:

1. For each test, connect the first specified resistance ( $R_1$ ) to the NI PXI-4132.
2. While taking a current measurement with the NI PXI-4132 ( $I_1$ ), use a DMM to measure the voltage across the output of the NI PXI-4132 ( $V_1$ ).
3. Change the load from  $R_1$  to  $R_2$  and repeat the previous step.
4. Record the voltage and current measurements for both resistances.
5. Calculate the voltage change limit using the following formula, where the current is in mA:

$$\text{Voltage Change Limit} = \pm (I_1 - I_2) * 0.0005 \text{ V}$$

6. Subtract the two voltage measurements  $V_1 - V_2$  to calculate the *Voltage Change*.

The test passes if the *Voltage Change* falls within the calculated *Voltage Change Limit*.

**Table 6.** NI PXI-4132 Voltage Load Regulation Verification Points

V Range	I Range	I Limit	Test Point	Load $R_1$	Load $R_2$	Measured				Voltage Change Limit (V)	Voltage Change (V)
						$I_1$ (mA)	$V_1$ (V)	$I_2$ (mA)	$V_2$ (V)		
10 V	100 mA	100 mA	10 V	120	1 k						

## Current Load Regulation

To verify current load regulation, use the NI PXI-4132 in constant current mode and confirm the output current change falls within calculated limits while varying the load voltage using different resistors. Table 7 lists the resistance values and measurements needed to complete verification. Refer to Figure 4 for the necessary connections.

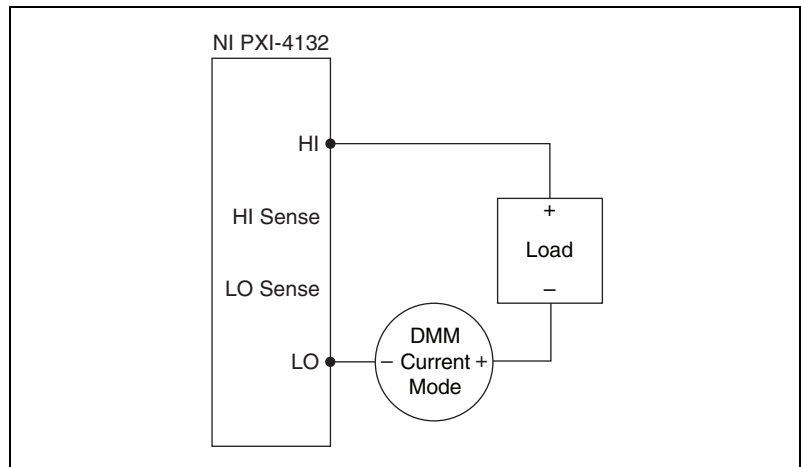

**Figure 4.** Current Load Regulation Verification Connection Diagram

Complete the following steps to verify current load regulation:

1. For each test, connect the first specified resistance ( $R_1$ ) to the NI PXI-4132.
2. While taking a voltage measurement with the NI PXI-4132 ( $V_1$ ), use a DMM in series to measure the output current ( $I_1$ ).
3. Change the load from  $R_1$  to  $R_2$  and repeat the previous step.
4. For each test, the units for all current measurements and calculations should be the same as the *I Range* unit. Record the current and voltage measurements for both resistances.

5. Calculate the current change limit using the following formula:  
 $Current\ Change\ Limit = \pm 0.0001 * I\ Range * (V_1 - V_2)$
6. Subtract the two current measurements  $I_1 - I_2$  to calculate the *Current Change*.

The test passes if the *Current Change* falls within the calculated *Current Change Limit*.

**Table 7.** NI PXI-4132 Current Load Regulation Verification Points

I Range	V Range	V Limit	Test Point	Load R <sub>1</sub>	Load R <sub>2</sub>	Measured				Current Change Limit	Current Change
						I <sub>1</sub>	V <sub>1</sub> (V)	I <sub>2</sub>	V <sub>2</sub> (V)		
10 uA	10 V	10 V	10 uA	100 k	900 k						
100 uA	10 V	10 V	100 uA	10 k	90 k						
1 mA	10 V	10 V	1 mA	1 k	9 k						
10 mA	10 V	10 V	10 mA	100	900						
100 mA	10 V	10 V	100 mA	10	90						

## Remote Sense Output Verification

To verify remote sense, complete the following steps using a test circuit of three resistors that simulate the voltage drop between the device and a load.

1. Connect a 50 Ω (R<sub>1</sub>), 1 kΩ (R<sub>2</sub>), and 50 Ω (R<sub>3</sub>) resistor in series, with the 1 kΩ resistor being the center resistor as shown in Figure 5.

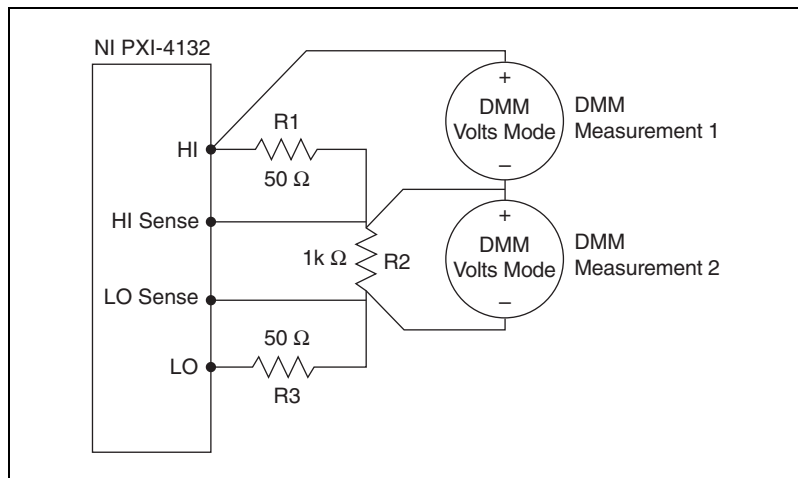

**Figure 5.** Remote Sense Output Verification Connection Diagram

2. Connect the resistors to the HI and LO terminals on the PXI-4132 as shown in Figure 5. Connect the remote sense leads directly across the 1 kΩ resistor (R<sub>2</sub>).

3. With remote sense On and a current limit of 100 mA, output 10 V in the 10 V range.
4. Measure the HI Lead Drop with a DMM (*DMM Measurement 1*) from the HI terminal of the NI PXI-4132 to the HI side of the 1 kΩ resistor.
5. Calculate the accuracy limit for the load voltage using the following equation:

$$\text{Load Voltage Limit} = 10 \text{ V} \pm (0.0055\text{V} + \text{HI Lead Drop} * 0.005)$$

6. Measure the load voltage with a DMM (*DMM Measurement 2*) across the 1 kΩ load where the sense leads connect.

The test passes if the *Load Voltage* measurement falls within the calculated *Load Voltage Limit*.

**Table 8.** NI PXI-4132 Remote Sense Output Verification Points

V Range	I Range	Test Point	Measured		Load Voltage Limit (V)
			HI Lead Drop (V)	Load Voltage (V)	
10 V	100 mA	10 V			

## Adjustment

Following the adjustment procedure automatically updates the calibration date and temperature on the NI PXI-4132.



**Note** National Instruments recommends a complete adjustment of your device to renew the calibration interval. However, if you do not want to perform an adjustment, you can update the calibration date and onboard calibration temperature without making any adjustments by calling only the niDCPower Initialize External Calibration VI or the niDCPower\_InitExtCal function and the niDCPower Close External Calibration VI or niDCPower\_CloseExtCal function with the action of **Commit**.

Adjustment corrects the following NI PXI-4132 specifications:

- Voltage programming accuracy
- Current programming accuracy
- Voltage measurement accuracy
- Current measurement accuracy

The adjustment components of the NI-DCPower API require the SMU be programmed using the voltage output function (this is the default configuration). To achieve a negative output current using the voltage function, specify a negative voltage level that ensures the SMU will operate in constant current mode, and specify the absolute value of the negative current as the current limit.

You must adjust each range with a separate call to an niDCPower Cal Adjust VI or function. For voltage and current output, adjust positive and negative polarities separately as well.

## Considerations

Figure 6 represents the general flow of an application used to adjust a range on the NI PXI-4132.

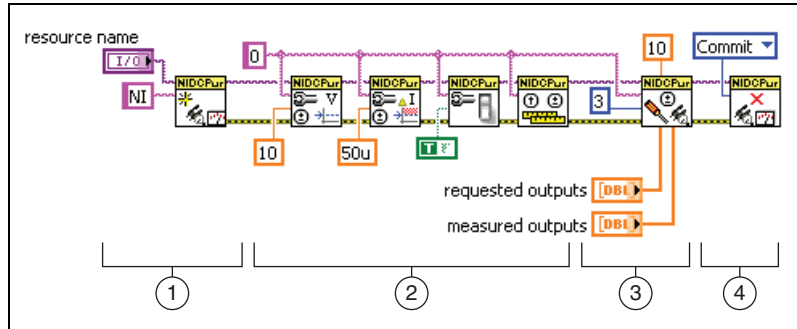

**Figure 6.** LabVIEW Block Diagram Illustrating Range Adjustment on the NI PXI-4132

1. **Initialize External Calibration Session:** To adjust the NI PXI-4132, call the niDCPower Initialize External Calibration VI or the niDCPower\_InitExtCal function to initiate a special type of NI-DCPower session.
2. **Configure the instrument:** Call a series of standard NI-DCPower VIs/functions specific to the adjustment of a particular range. These calls vary depending on the requirements of the range being adjusted. Typical operations in this step include configuring ranges, setting output levels, or taking measurements. Measurements made by external equipment required for adjustment also occur during this step. For assistance configuring the NI PXI-4132 to a particular output or measurement mode, refer to the example programs installed with NI-DCPower.
3. **Call niDCPower Cal Adjust function(s):** When the measurements required for adjustment of a range are complete, call one of the niDCPower Cal Adjust VIs or functions to calculate new calibration coefficients and store them in memory on the host. Calling these VIs/functions does *not* commit the new coefficients to hardware.
4. **Close session and commit new calibration coefficients:** To complete adjustment of the range, call the niDCPower Close External Calibration VI or niDCPower\_CloseExtCal function to close the session. To write new calibration coefficients to the hardware, specify an action of **Commit**. At this time, the calibration date and temperature stored on board are also updated.



**Note** You can adjust any voltage or current range individually by opening a calibration session, adjusting, and then closing the session with an action of **Commit**. To adjust all voltage and current ranges at one time, open a single calibration session, execute multiple adjustment steps, and then close the session with an action of **Commit** to write coefficients for multiple ranges simultaneously.

## Adjusting Voltage Output

To adjust voltage output, compare a set of requested voltage set points to measurements of the actual voltage at the output by an external DMM. Refer to Figure 1 for the necessary connections.

Table 9 outlines the voltage set points that you must request and measure for each range. For example, the 10 V range requires the adjustment application to separately request  $-1$  nV,  $-5$  V, and  $-10$  V outputs and  $0$  V,  $5$  V, and  $10$  V outputs from the NI PXI-4132. Take measurements using the external DMM at each voltage set point.



**Note** Do not use the NI-DCPower Soft Front Panel (SFP) to request set points for adjusting voltage outputs.

To ensure the system has had adequate time to settle, wait one second after requesting a new voltage before taking a measurement with the DMM.

**Table 9.** NI PXI-4132 Voltage Output Adjustment Points

Voltage Output Range	10 V		100 V	
Polarity	+	-	+	-
Required Adjustment Set Points	0 V	$-1$ nV	0 V	$-1$ nV
	5 V	$-5$ V	50 V	$-50$ V
	10 V	$-10$ V	100 V	$-100$ V

After all set points have been measured for a range, call the `niDCPower Cal Adjust Voltage Level VI` or the `niDCPower_CalAdjustVoltageLevel` function to calculate updated calibration coefficients. Some notable parameters to this VI/function are specific to adjustment applications and are explained in Table 10. Others are common to many VIs/functions within the NI-DCPower API that are explained in more detail in the programming references included in the *NI DC Power Supplies and SMUs Help*.

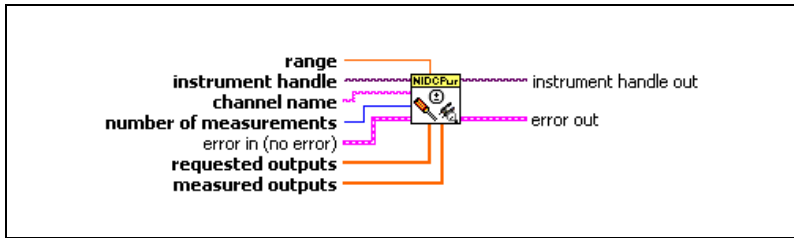

**Figure 7.** NI-DCPower Cal Adjust Voltage Level VI

**Table 10.** NI-DCPower Cal Adjust Voltage Level VI/Function Parameter Descriptions

VI/Function Parameter	Description
range	The range to be adjusted with these settings
requested outputs	Array of requested voltage set points required for adjustment of a range. For example, this would be 0, 5, and 10 for the positive half of the 10 V range.
measured outputs	Array of measurements made by external DMM corresponding to <i>requested outputs</i>
number of measurements	The number of elements in <i>requested outputs</i> and <i>measured outputs</i>

When the new coefficients have been calculated, commit them to the hardware using the process described in the *Considerations* section.



**Note** Adjust positive and negative current polarities with separate calls to the `niDCPower Cal Adjust Voltage Level VI` or the `niDCPower_CalAdjustVoltageLevel` function.

## Adjusting Current Output

To adjust current output, compare a set of requested current set points to measurements of the actual current at the output by an external DMM. Refer to Figure 2 for the necessary connections.

Table 11 lists the current set points that you must request and measure for each range. For example, the 10  $\mu\text{A}$  range requires the adjustment application to acquire data from ten negative and ten positive set points using an external DMM.

To ensure the system has had adequate time to settle, wait one second after requesting a new current before taking a measurement with the DMM.

**Table 11.** NI PXI-4132 Current Output Adjustment Points

Current Output Range	10 $\mu$ A		100 $\mu$ A		1 mA		10 mA		100 mA	
	+	-	+	-	+	-	+	-	+	-
Required Adjustment Set Points	0.2 $\mu$ A	-0.2 $\mu$ A	2 $\mu$ A	-2 $\mu$ A	0.02 mA	-0.02 mA	0.2 mA	-0.2 mA	2 mA	-2 mA
	1.289 $\mu$ A	-1.289 $\mu$ A	12.89 $\mu$ A	-12.89 $\mu$ A	0.1289 mA	-0.1289 mA	1.289 mA	-1.289 mA	12.890 mA	-12.890 mA
	2.378 $\mu$ A	-2.378 $\mu$ A	23.78 $\mu$ A	-23.78 $\mu$ A	0.2378 mA	-0.2378 mA	2.378 mA	-2.378 mA	23.78 mA	-23.78 mA
	3.467 $\mu$ A	-3.467 $\mu$ A	34.67 $\mu$ A	-34.67 $\mu$ A	0.3467 mA	-0.3467 mA	3.467 mA	-3.467 mA	34.67 mA	-34.67 mA
	4.556 $\mu$ A	-4.556 $\mu$ A	45.56 $\mu$ A	-45.56 $\mu$ A	0.4556 mA	-0.4556 mA	4.556 mA	-4.556 mA	45.56 mA	-45.56 mA
	5.644 $\mu$ A	-5.644 $\mu$ A	56.44 $\mu$ A	-56.44 $\mu$ A	0.5644 mA	-0.5644 mA	5.644 mA	-5.644 mA	56.44 mA	-5.644 mA
	6.733 $\mu$ A	-6.733 $\mu$ A	67.33 $\mu$ A	-67.33 $\mu$ A	0.6733 mA	-0.6733 mA	6.733 mA	-6.733 mA	67.33 mA	-67.33 mA
	7.822 $\mu$ A	-7.822 $\mu$ A	78.22 $\mu$ A	-78.22 $\mu$ A	0.7822 mA	-0.7822 mA	7.822 mA	-7.822 mA	78.22 mA	-78.22 mA
	8.911 $\mu$ A	-8.911 $\mu$ A	89.11 $\mu$ A	-89.11 $\mu$ A	0.8911 mA	-0.8911 mA	8.911 mA	-8.911 mA	89.11 mA	-89.11 mA
	10 $\mu$ A	-10 $\mu$ A	100 $\mu$ A	-100 $\mu$ A	1 mA	-1 mA	10 mA	-10 mA	100 mA	-100 mA

After all set points have been measured for a range, call the niDCPower Cal Adjust Current Limit VI or the niDCPower\_CalAdjustCurrentLimit function to calculate updated calibration coefficients. Some parameters to this VI/function are specific to adjustment applications and are explained in Table 12. Others are common to many VIs/functions within the NI-DCPower API that are explained in more detail in the programming references included in the *NI DC Power Supplies and SMUs Help*.



**Note** Adjust positive and negative current polarities with separate calls to the niDCPower Cal Adjust Current Limit VI or the niDCPower\_CalAdjustCurrentLimit function.

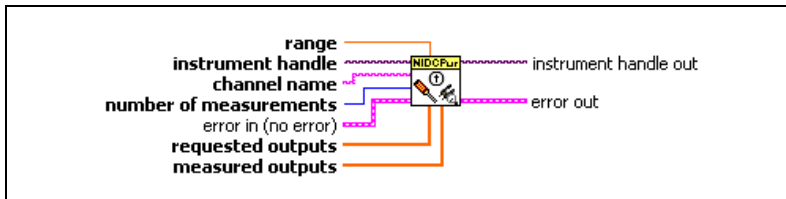

**Figure 8.** NI-DCPower Cal Adjust Current Limit VI

**Table 12.** NI-DCPower Cal Adjust Current Limit VI/Function Parameter Descriptions

Parameter	Description
range	The range to be adjusted with these settings
requested outputs	Array of requested currents required for adjustment of a range. For example, this would be the ten set points listed in Table 11 for each range polarity. Requested output currents can not be negative. For negative polarities, calculate the absolute value.
measured outputs	Array of measurements made by external DMM corresponding to <i>requested outputs</i> . Measurements can be entered as positive or negative.
number of measurements	The number of elements in <i>requested outputs</i> and <i>measured outputs</i>

When the new coefficients have been calculated, commit them to the hardware using the process described in the [Considerations](#) section.

## Adjusting Voltage Measurement

To adjust voltage measurement, compare a set of voltage set points as measured by an external DMM to the measured voltage reported by the NI PXI-4132. Refer to Figure 1 for the necessary connections.

Table 13 lists the voltage set points that you must measure and request with both an external DMM and the NI PXI-4132 to adjust a given range. For example, the 10 V range requires the adjustment application to separately request 10 V, 0 V, and –10 V outputs from the NI PXI-4132. Take measurements using the external DMM and NI PXI-4132 at each point.

To ensure the system has had adequate time to settle, wait one second after requesting a new voltage before taking a measurement with the DMM and the NI PXI-4132.

**Table 13.** NI PXI-4132 Voltage Measurement Adjustment Points

Voltage Output Range	10 V	100 V
Required Adjustment Set Points	10 V	100 V
	0 V	0 V
	–10 V	–100 V

After all set points have been measured for a range, use the `niDCPower Cal Adjust Voltage Measurement VI` or the `niDCPower_CalAdjustVoltageMeasurement` function to calculate updated calibration coefficients. Some notable parameters to this

VI/function are specific to adjustment applications and are explained in Table 14. Others are common to many VIs/functions within the NI-DCPower API that are explained in more detail in the programming references included in the *NI DC Power Supplies and SMUs Help*.

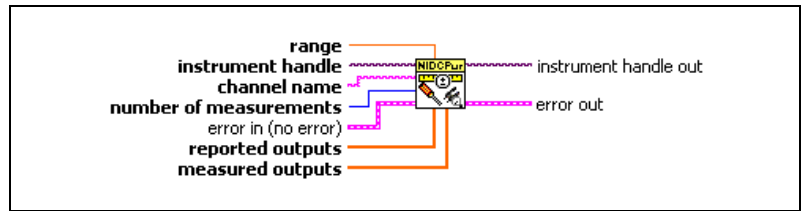

**Figure 9.** NI-DCPower Cal Adjust Voltage Measurement VI

**Table 14.** NI-DCPower Cal Adjust Voltage Measurement VI/Function Parameter Descriptions

VI/Function Parameter	Description
range	The range to be adjusted with these settings
reported outputs	Array of measurements taken by the NI PXI-4132 corresponding to required adjustment set points in Table 13
measured outputs	Array of measurements taken by an external DMM corresponding to <i>requested outputs</i>
number of measurements	The number of elements in <i>requested outputs</i> and <i>measured outputs</i>

When the new coefficients have been calculated, commit them to the hardware using the process described in the [Considerations](#) section.

## Adjusting Current Measurement

To adjust current measurement, compare a set of current set points as measured by an external DMM to the measured current reported by the NI PXI-4132. Refer to Figure 2 for the necessary connections.

Table 15 outlines the current set points that you must measure and request with both an external DMM and the NI PXI-4132 to adjust a given range. For example, the 10  $\mu\text{A}$  range requires the adjustment application to separately request 10  $\mu\text{A}$ , 0  $\mu\text{A}$ , and  $-10 \mu\text{A}$  outputs from the NI PXI-4132. Take measurements using the external DMM and NI PXI-4132 at each point.

To ensure the system has had adequate time to settle, wait one second after requesting a new voltage before taking a measurement with the DMM and the NI PXI-4132.

**Table 15.** NI PXI-4132 Current Output Adjustment Points

Current Output Range	10 $\mu$ A	100 $\mu$ A	1 mA	10 mA	100 mA
Required Adjustment Set Points	10 $\mu$ A	100 $\mu$ A	1 mA	10 mA	100 mA
	0 $\mu$ A	0 $\mu$ A	0 mA	0 mA	0 mA
	-10 $\mu$ A	-100 $\mu$ A	-1 mA	-10 mA	-100 mA



**Note** When measuring a 0 A set point, remove any connections to the front panel I/O connector to ensure no current is flowing through the output instead of measuring with an external DMM. Any valid current limit can be specified during this process, as the actual output current is always zero.

After all set points have been measured for a range, call the `niDCPower Cal Adjust Current Measurement VI` or the `niDCPower_CalAdjustCurrentMeasurement` function to calculate updated calibration coefficients. Some parameters to this VI/function are specific to adjustment applications and are explained in Table 16. Others are common to many VIs/functions within the NI-DCPower API that are explained in more detail in the programming references included in the *NI DC Power Supplies and SMUs Help*.

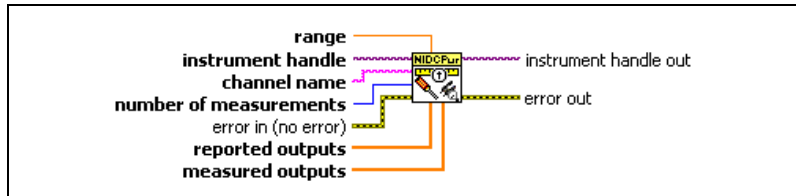

**Figure 10.** NI-DCPower Cal Adjust Current Measurement VI

**Table 16.** NI-DCPower Cal Adjust Current Measurement VI/Function Parameter Descriptions

VI/Function Parameter	Description
range	The range to be adjusted with these settings
reported outputs	Array of measurements taken by the NI PXI-4132 corresponding to required adjustment set points in Table 15
measured outputs	Array of measurements made by external DMM corresponding to required adjustment set points in Table 15. For zero current set points, a measured output of exactly zero should be entered as all connection to the NI PXI-4132 should be removed to take this measurement.
number of measurements	The number of elements in <i>reported outputs</i> and <i>measured outputs</i>

When the new coefficients have been calculated, commit them to the hardware using the process described in the *Considerations* section.

# Where to Go for Support

---

The National Instruments Web site is your complete resource for technical support. At [ni.com/support](http://ni.com/support) you have access to everything from troubleshooting and application development self-help resources to email and phone assistance from NI Application Engineers.

National Instruments corporate headquarters is located at 11500 North Mopac Expressway, Austin, Texas, 78759-3504. National Instruments also has offices located around the world to help address your support needs. For telephone support in the United States, create your service request at [ni.com/support](http://ni.com/support) and follow the calling instructions or dial 512 795 8248. For telephone support outside the United States, contact your local branch office:

Australia 1800 300 800, Austria 43 662 457990-0,  
Belgium 32 (0) 2 757 0020, Brazil 55 11 3262 3599,  
Canada 800 433 3488, China 86 21 5050 9800,  
Czech Republic 420 224 235 774, Denmark 45 45 76 26 00,  
Finland 358 (0) 9 725 72511, France 01 57 66 24 24,  
Germany 49 89 7413130, India 91 80 41190000, Israel 972 3 6393737,  
Italy 39 02 41309277, Japan 0120-527196, Korea 82 02 3451 3400,  
Lebanon 961 (0) 1 33 28 28, Malaysia 1800 887710,  
Mexico 01 800 010 0793, Netherlands 31 (0) 348 433 466,  
New Zealand 0800 553 322, Norway 47 (0) 66 90 76 60,  
Poland 48 22 328 90 10, Portugal 351 210 311 210,  
Russia 7 495 783 6851, Singapore 1800 226 5886,  
Slovenia 386 3 425 42 00, South Africa 27 0 11 805 8197,  
Spain 34 91 640 0085, Sweden 46 (0) 8 587 895 00,  
Switzerland 41 56 2005151, Taiwan 886 02 2377 2222,  
Thailand 662 278 6777, Turkey 90 212 279 3031,  
United Kingdom 44 (0) 1635 523545

CVI, National Instruments, NI, ni.com, and LabVIEW are trademarks of National Instruments Corporation. Refer to the *Terms of Use* section on [ni.com/legal](http://ni.com/legal) for more information about National Instruments trademarks. The mark LabWindows is used under a license from Microsoft Corporation. Windows is a registered trademark of Microsoft Corporation in the United States and other countries. Other product and company names mentioned herein are trademarks or trade names of their respective companies. For patents covering National Instruments products/technology, refer to the appropriate location: **Help»Patents** in your software, the `patents.txt` file on your media, or the *National Instruments Patent Notice* at [ni.com/patents](http://ni.com/patents).