

## INSTALLATION GUIDE

# SCXI™-1313A Terminal Block

This guide describes how to install and use the SCXI-1313A terminal block with an SCXI-1125 module.

The SCXI-1313A terminal block is shielded and has screw terminals that provide input connections for the SCXI-1125. Each SCXI-1313A channel has a precision 100:1 resistive voltage divider that you can use to measure voltages of up to 150 V<sub>rms</sub> or ±150 VDC. You can individually bypass these voltage dividers for low-voltage measurement applications.

The terminal block has 18 screw terminals for easy signal connection. One pair of screw terminals connects to the SCXI-1125 chassis ground. The remaining eight pairs of screw terminals connect signals to the eight analog inputs.

## Conventions

---

The following conventions are used in this guide:

»

The » symbol leads you through nested menu items and dialog box options to a final action. The sequence **File»Page Setup»Options** directs you to pull down the **File** menu, select the **Page Setup** item, and select **Options** from the last dialog box.



This icon denotes a note, which alerts you to important information.



This icon denotes a caution, which advises you of precautions to take to avoid injury, data loss, or a system crash. When this symbol is marked on a product, refer to the *Read Me First: Safety and Radio-Frequency Interference* for information about precautions to take.



When symbol is marked on a product, it denotes a warning advising you to take precautions to avoid electrical shock.



When symbol is marked on a product, it denotes a component that may be hot. Touching this component may result in bodily injury.

<b>bold</b>	Bold text denotes items that you must select or click in the software, such as menu items and dialog box options. Bold text also denotes parameter names.
<i>italic</i>	Italic text denotes variables, emphasis, a cross-reference, or an introduction to a key concept. Italic text also denotes text that is a placeholder for a word or value that you must supply.
monospace	Text in this font denotes text or characters that you should enter from the keyboard, sections of code, programming examples, and syntax examples. This font is also used for the proper names of disk drives, paths, directories, programs, subprograms, subroutines, device names, functions, operations, variables, filenames, and extensions.
<i>monospace italic</i>	Italic text in this font denotes text that is a placeholder for a word or value that you must supply.

## What You Need to Get Started

---

To set up and use the SCXI-1313A terminal block, you need the following items:

- Hardware
  - SCXI-1313A terminal block
  - SCXI-1125 module
  - SCXI or PXI/SCXI combination chassis
  - Cabling and sensors as required for your application
- Tools
  - Number 1 and 2 Phillips-head screwdrivers
  - 1/8 in. flathead screwdriver
  - Long-nose pliers
  - Wire cutter
  - Wire insulation stripper
- Documentation
  - *SCXI-1313A Terminal Block Installation Guide*
  - *Read Me First: Safety and Radio-Frequency Interference*
  - *DAQ Getting Started Guide*
  - *SCXI Quick Start Guide*
  - *SCXI-1125 User Manual*
  - SCXI chassis or PXI/SCXI combination chassis user manual

You can download needed documents from [ni.com/manuals](http://ni.com/manuals).

# Connecting Signals



**Note** Refer to the *Read Me First: Safety and Radio-Frequency Interference* document before removing equipment covers or connecting or disconnecting any signal wires.

To connect the signal to the terminal block, refer to Figures 1 and 2 while completing the following steps:

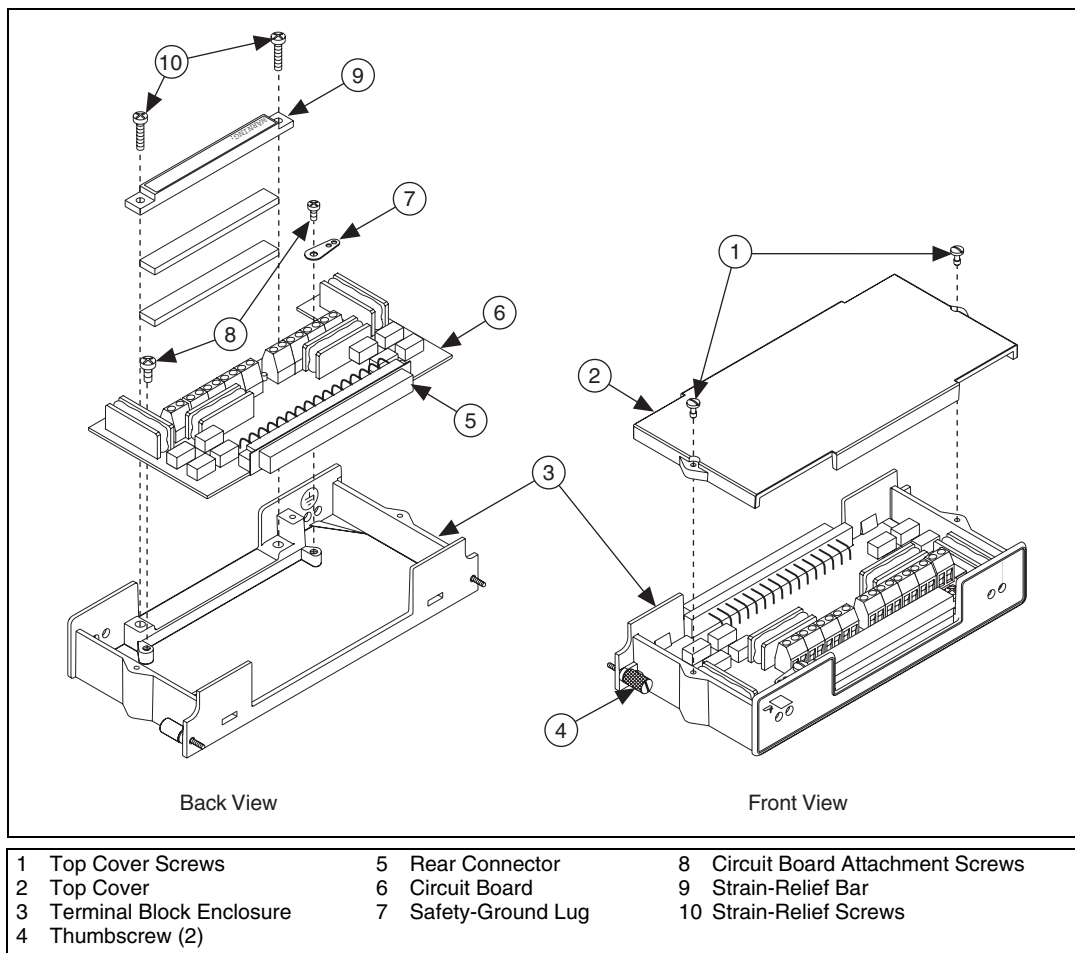

**Figure 1.** SCXI-1313A Parts Locator Diagram

1. Unscrew the top cover screws and remove the top cover.
2. Loosen the strain-relief screws and remove the strain-relief bar.
3. Prepare the signal wire by stripping the insulation no more than 7 mm (0.28 in.).

4. Run the signal wires through the strain-relief opening. If necessary, add insulation or padding.
5. Insert the stripped end of the signal wires fully into the terminal. Make sure no exposed wire extends past the screw terminal. Exposed wire increases the risk of a short circuit that can cause circuit failure.

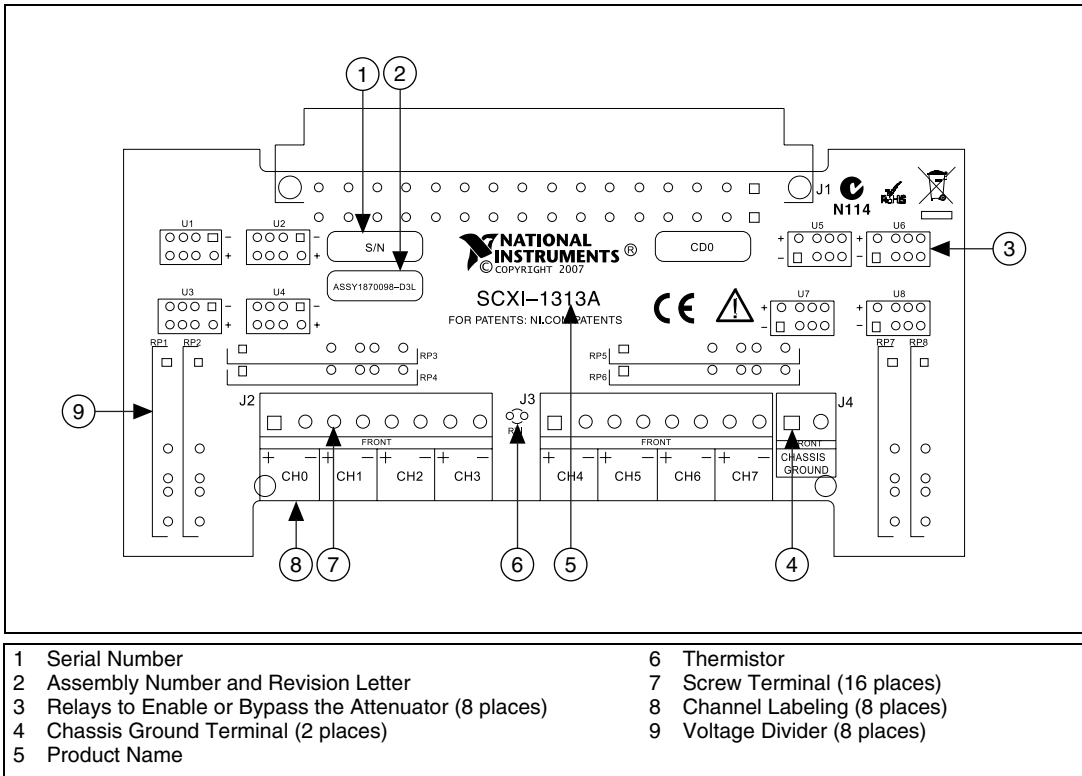

**Figure 2.** SCXI-1313A Circuit Board Parts Locator Diagram

6. Tighten the terminal screws to a torque of 0.57 to 0.79 N · m (5 to 7 lb - in.).
7. Reinstall the strain-relief bar and tighten the strain-relief screws.
8. Reinstall the top cover and tighten the top cover screws.
9. Attach the SCXI-1313A to the SCXI-1125 using the thumbscrews.
10. Refer to the *SCXI Quick Start Guide* to power on the SCXI chassis and configure the system in software.



**Note** For accurate cold-junction compensation, place the chassis away from an extreme temperature differential.

# Configuring the High-Voltage Attenuator

Each channel has a 100:1 high-voltage attenuator. To enable or disable the attenuator, either change the default configuration settings for the SCXI-1313A in Measurement & Automation Explorer (MAX) or adjust the input limit ranges in your application. When using virtual channels, the input limits configured in the virtual channel configurator are used to set the attenuation circuitry appropriately.



**Note** SCXI-1313 is the designator for both the SCXI-1313 and SCXI-1313A in MAX and NI-DAQ.

The calibration EEPROM on the SCXI-1313A stores calibration constants that provide software correction values. These values are used by the application development software to correct the measurements for gain errors in the attenuation circuitry.

**Table 1.** Input Signal Range Versus Gain

Overall Gain	Overall Voltage Range <sup>1</sup>	Module Gain	Terminal Block Gain
0.02	$\pm 150 V_{\text{rms}}$ or $\pm 150 \text{ VDC}$	2	0.01
0.05	$\pm 100 V_{\text{peak}}$ or $\pm 100 \text{ VDC}$	5	0.01
0.1	$\pm 50 V_{\text{peak}}$ or $\pm 50 \text{ VDC}$	10	0.01
0.2	$\pm 25 V_{\text{peak}}$ or $\pm 25 \text{ VDC}$	20	0.01
0.5	$\pm 10 V_{\text{peak}}$ or $\pm 10 \text{ VDC}$	50	0.01
1	$\pm 5 V_{\text{peak}}$ or $\pm 5 \text{ VDC}$	1	1
2	$\pm 2.5 V_{\text{peak}}$ or $\pm 2.5 \text{ VDC}$	2	1
2.5	$\pm 2 V_{\text{peak}}$ or $\pm 2 \text{ VDC}$	250	0.01
5	$\pm 1 V_{\text{peak}}$ or $\pm 1 \text{ VDC}$	5	1
10	$\pm 500 \text{ mV}_{\text{peak}}$ or $\pm 500 \text{ mVDC}$	10	1
20	$\pm 250 \text{ mV}_{\text{peak}}$ or $\pm 250 \text{ mVDC}$	20	1
50	$\pm 100 \text{ mV}_{\text{peak}}$ or $\pm 100 \text{ mVDC}$	50	1
100	$\pm 50 \text{ mV}_{\text{peak}}$ or $\pm 50 \text{ mVDC}$	100	1
200	$\pm 25 \text{ mV}_{\text{peak}}$ or $\pm 25 \text{ mVDC}$	200	1
250	$\pm 20 \text{ mV}_{\text{peak}}$ or $\pm 20 \text{ mVDC}$	250	1

**Table 1.** Input Signal Range Versus Gain (Continued)

Overall Gain	Overall Voltage Range <sup>1</sup>	Module Gain	Terminal Block Gain
500	±10 mV <sub>peak</sub> or ±10 mVDC	500	1
1000	±5 mV <sub>peak</sub> or ±5 mVDC	1000	1
2000	±2.5 mV <sub>peak</sub> or ±2.5 mVDC	2000	1

<sup>1</sup> Refer to the *Specifications* section for the input range.

## Calibrating the Terminal Block

---

Most external calibration documents for SCXI product are available to download from [ni.com/calibration](http://ni.com/calibration) by clicking **Manual Calibration Procedures**. For external calibration of products not listed there, Basic Calibration Service or Detailed Calibration Service is recommended. You can get information about both of these calibration services at [ni.com/calibration](http://ni.com/calibration). NI recommends performing an external calibration once a year.

## Temperature Sensor Output and Accuracy

---

The SCXI-1313A temperature sensor outputs 1.91 to 0.65 V from 0 to 50 °C.

### Converting a Thermistor Voltage to a Temperature

NI software can convert a thermistor voltage to the thermistor temperature for the circuit diagram shown in Figure 3. In LabVIEW, you can use the Convert Thermistor Reading VI found in the **Data Acquisition»Signal Conditioning** palette. If you are using CVI or NI-DAQmx, use the `Thermistor_Convert` function. The VI takes the output voltage of the temperature sensor, the reference voltage, and the precision resistance and returns the thermistor temperature.

Alternatively, you can use the following formulas:

$$T(^{\circ}\text{C}) = T_K - 273.15$$

where  $T_K$  is the temperature in Kelvin

$$T_K = \frac{1}{[a + b(\ln R_T) + c(\ln R_T)^3]}$$

$$a = 1.295361 \times 10^{-3}$$

$$b = 2.343159 \times 10^{-4}$$

$$c = 1.018703 \times 10^{-7}$$

$R_T$  = resistance of the thermistor in ohms

$$R_T = 5,000 \left( \frac{V_{TEMPOUT}}{2.5 - V_{TEMPOUT}} \right)$$

$V_{TEMPOUT}$  = output voltage of the temperature sensor

$$T(^{\circ}F) = \frac{[T(^{\circ}C)]9}{5} + 32$$

where  $T(^{\circ}F)$  and  $T(^{\circ}C)$  are the temperature readings in degrees Fahrenheit and degrees Celsius, respectively.



**Note** Use an average of a large number of samples to obtain the most accurate reading. Noisy environments require more samples for greater accuracy.

## Reading the Temperature Sensor in LabVIEW

In LabVIEW, to read  $V_{TEMPOUT}$ , use NI-DAQmx with the following string:

```
SC(x)Mod(y)/_cjTemp
```

To read  $V_{TEMPOUT}$  with Traditional NI-DAQ (Legacy), use the address string:

```
obx ! scy ! mdz ! cjtemp
```

You can have this channel-address string in the same channel-string array as other channels on the same SCXI-1125 module and call it multiple times within the same channel-string array.

For more information about channel-string arrays and the SCXI channel-addressing syntax, see the *LabVIEW Measurements Manual*.

# Temperature Sensor Circuit Diagram

You do *not* need to read this section to operate the SCXI-1313A. The circuit diagram in Figure 3 is optional information that you can use if you want more details about the SCXI-1313A temperature sensor.

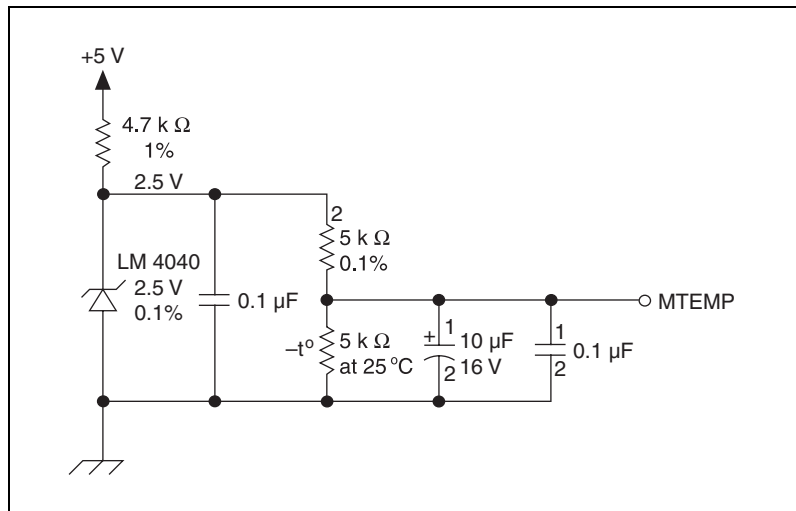

**Figure 3.** Temperature Sensor Circuit Diagram

## Specifications

All specifications are typical at 25 °C unless otherwise specified.

Input range ..... 150 V<sub>rms</sub> or VDC

Input channels ..... 8

Cold-junction sensor

Sensor type ..... Thermistor

Accuracy<sup>1</sup> ..... ±0.5 °C from 15 to 35 °C  
 ±0.9 °C from 0 to 15 °C  
 and 35 to 55 °C

Repeatability ..... ±0.2 °C from 15 to 35 °C

<sup>1</sup> The temperature sensor accuracy includes tolerances in all component values, effects caused by temperature and loading, and self-heating. Errors caused by temperature gradients between terminals and the sensor are not included in this specification.

Output .....	1.91 to 0.65 V from 0 to 50 °C
Maximum temperature gradient between sensor and any terminal ....	±0.4 °C (non-isothermal)
High-voltage divider	
Accuracy .....	±0.06% (for 100:1 setting)
Drift.....	15 ppm/°C
Resistance .....	1 MΩ
Attenuation ratio .....	100:1 or 1:1 on programmatic basis
Common-mode isolation	
Channel to channel.....	150 V <sub>rms</sub> or ±150 VDC
Channel to ground.....	150 V <sub>rms</sub> or ±150 VDC
Coupling.....	DC only
Field-wiring connectors	
Screw terminals	
Signal terminals .....	16 (8 pairs)
Functional ground terminals....	2
Maximum wire gauge .....	16 AWG
Terminal spacing .....	0.5 cm (0.2 in.) center-to-center
Dimensions of front entrance.....	1.2 × 7.3 cm (0.47 × 2.87 in.)
Solder pads for additional components .....	None
Safety earth-ground lugs.....	1
Strain relief .....	Strain-relief bar at terminal-block entrance
Maximum working voltage .....	150 V

# Physical

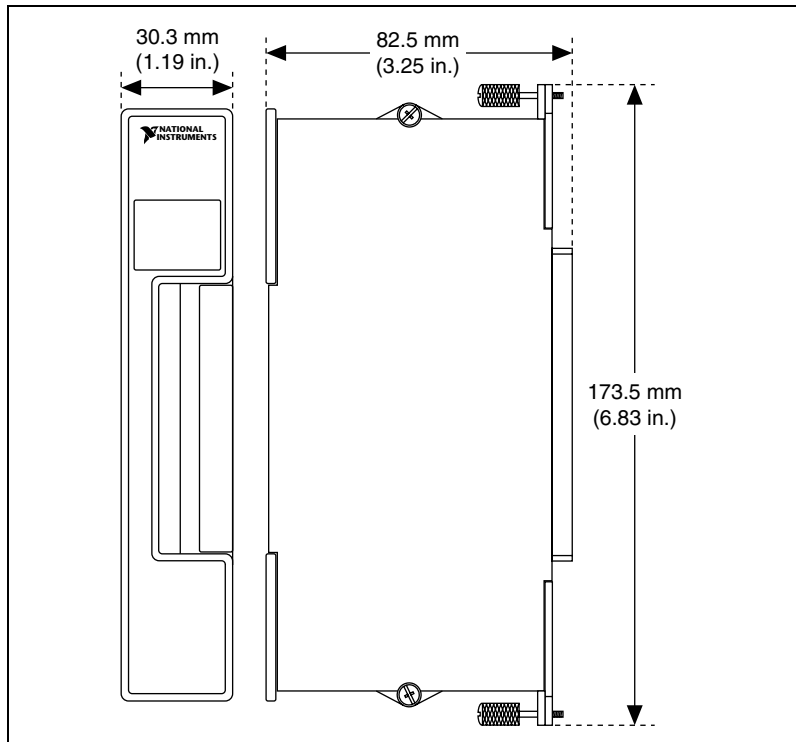

**Figure 4.** SCXI-1313A Dimensions

Weight .....408 g (14.4 oz)

# Environment

Operating temperature .....0 to 50 °C

Storage temperature .....-20 to 70 °C

Humidity .....10 to 90% RH, noncondensing

Maximum altitude.....2,000 meters

Pollution Degree (indoor use only) .....2

## Safety

This product is designed to meet the requirements of the following standards of safety for electrical equipment for measurement, control, and laboratory use:

- IEC 61010-1, EN 61010-1
- UL 61010-1, CSA 61010-1



**Note** For UL and other safety certifications, refer to the product label or visit [ni.com/certification](http://ni.com/certification), search by model number or product line, and click the appropriate link in the Certification column.

## Electromagnetic Compatibility

This product is designed to meet the requirements of the following standards of EMC for electrical equipment for measurement, control, and laboratory use:

- EN 61326 EMC requirements; Minimum Immunity
- EN 55011 Emissions; Group 1, Class A
- CE, C-Tick, ICES, and FCC Part 15 Emissions; Class A



**Note** For EMC compliance, operate this device according to product documentation.

## CE Compliance

This product meets the essential requirements of applicable European Directives, as amended for CE marking, as follows:

- 2006/95/EC; Low-Voltage Directive (safety)
- 2004/108/EC; Electromagnetic Compatibility Directive (EMC)



**Note** Refer to the Declaration of Conformity (DoC) for this product for any additional regulatory compliance information. To obtain the DoC for this product, visit [ni.com/certification](http://ni.com/certification), search by model number or product line, and click the appropriate link in the Certification column.

# Environmental Management

National Instruments is committed to designing and manufacturing products in an environmentally responsible manner. NI recognizes that eliminating certain hazardous substances from our products is beneficial not only to the environment but also to NI customers.

For additional environmental information, refer to the *NI and the Environment* Web page at [ni.com/environment](http://ni.com/environment). This page contains the environmental regulations and directives with which NI complies, as well as any other environmental information not included in this document.

## Waste Electrical and Electronic Equipment (WEEE)



**EU Customers** At the end of their life cycle, all products *must* be sent to a WEEE recycling center. For more information about WEEE recycling centers and National Instruments WEEE initiatives, visit [ni.com/environment/weee.htm](http://ni.com/environment/weee.htm).

## 电子信息产品污染控制管理办法（中国 RoHS）



**中国客户** National Instruments 符合中国电子信息产品中限制使用某些有害物质指令 (RoHS)。关于 National Instruments 中国 RoHS 合规性信息，请登录 [ni.com/environment/rohs\\_china](http://ni.com/environment/rohs_china)。(For information about China RoHS compliance, go to [ni.com/environment/rohs\\_china](http://ni.com/environment/rohs_china).)