

USER GUIDE

NI 653x Cable Adapter

The NI 653x cable adapter interfaces with National Instruments high-speed digital I/O (DIO) devices. The cable adapter provides an easy way to connect the Very High Density Connector Interface (VHDCI) connectors, labeled as *Digital Data & Control*, on the newer NI 6535/6536/6537 devices to the 68-pin DAQ connectors found on older NI 6533/6534 accessories and fixturing. The 653x cable adapter is also compatible with the NI 654x and NI 655x digital pattern generator/analyzer devices.

For best signal integrity, NI recommends using the NI 6535/6536/6537 devices with newer accessories such as the NI CB-2162 and NI SMB-2163.

This guide explains how to set up and use the NI 653x cable adapter.

Contents

What You Need to Get Started	2
Related Documentation	2
Parts Locator Diagram	3
Installing Cables	4
Removing the NI 653x Cable Adapter from its Enclosure	5
Connecting Signals	6
Custom Wiring Example	11
Specifications	13
Digital I/O	13
Traces	13
Power	13
Physical	13
Where to Go for Support	14

What You Need to Get Started

To set up and use the NI 653x cable adapter, you need the following items:

- NI SHC68-C68-D2 or NI C68-C68-D4 cable assembly (for NI 6535/6536/6537/654x/655x devices)
- Compatible NI high-speed digital I/O device (NI 6535/6536/6537/654x/655x)
- (Optional) 22- to 26-gauge wire
- (Optional) The documentation included with the NI high-speed DIO device and the driver software included with your device
- (Optional) NI 6533 or NI 6534 supported terminal block

Related Documentation

National Instruments high-speed DIO devices ship with several documents designed to familiarize you with different aspects of the device. The titles and location of the documents vary based on the driver that supports the NI device, but you should have the following types of documentation:

- **Getting Started Guide**—This printed document should be the first thing you read. Its purpose is to guide you through setting up the high-speed DIO device and configuring it to generate or acquire your first samples.
- **Help**—This online document provides more in-depth information about the hardware capabilities of the high-speed DIO device, theory of operation discussion, and information on programming flow and software reference.
- **Specifications**—This printed document provides specifications for the NI hardware.

Visit ni.com/manuals for the most current documentation.

You also may have documentation for any application development environment (ADE) you are using.

Parts Locator Diagram

Refer to Figure 1 to locate connectors and components on the NI 653x cable adapter.

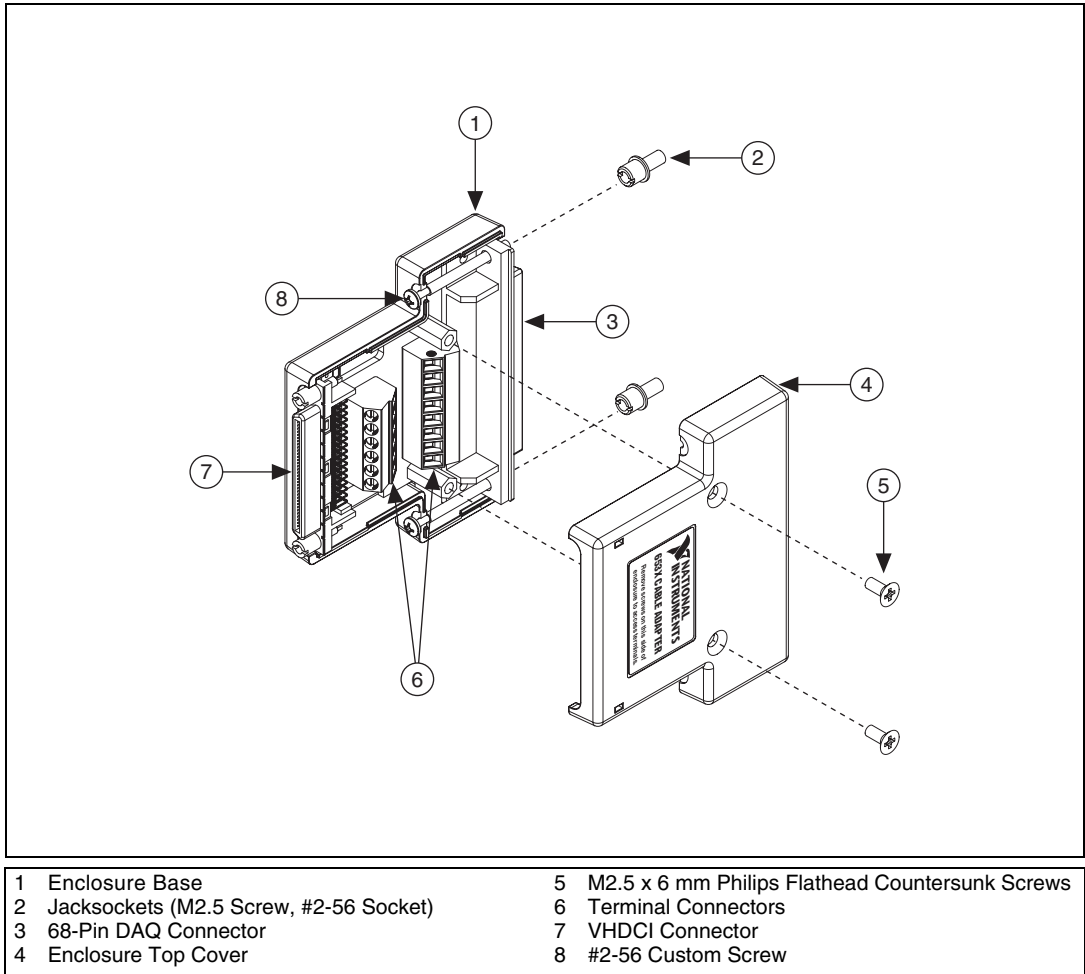

Figure 1. NI 653x Cable Adapter Parts Locator Diagram

Installing Cables

An SHC68-C68-D2 or C68-C68-D4 cable connects the NI 653x cable adapter to the NI high-speed DIO device. Figure 2 shows how to install the cable.

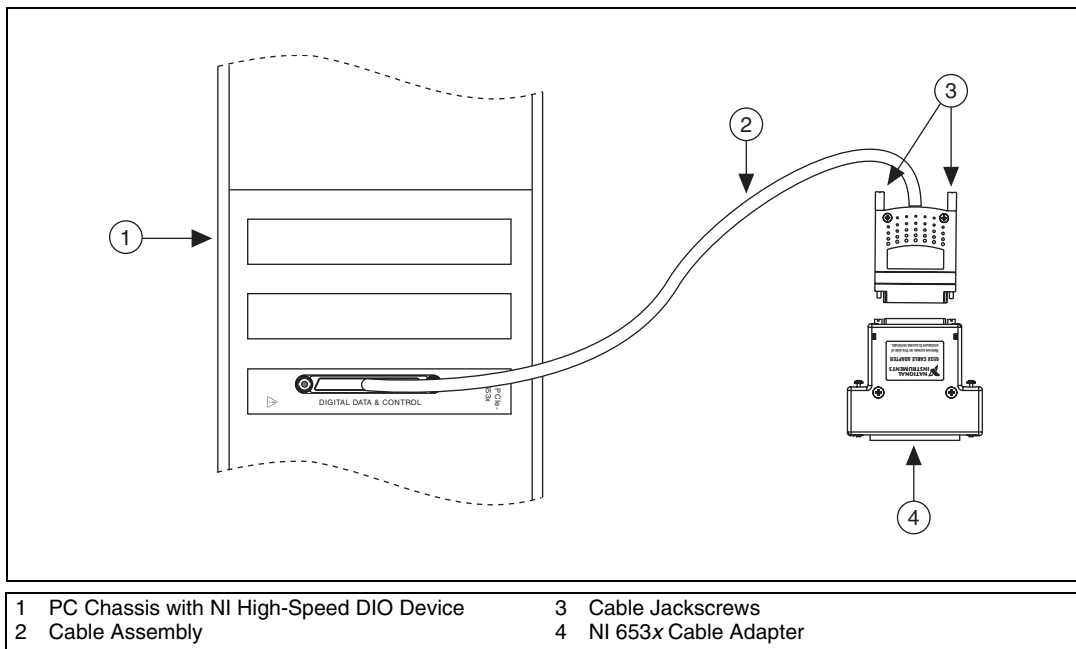

Figure 2. Connecting a SHC68-C68-D2 or C68-C68-D4 Cable to the NI 653x Cable Adapter



Caution Before connecting the cable, disconnect power from the NI device and any other connected hardware to prevent damage to the hardware and personal injury. NI is *not* liable for damage resulting from improper connections.

Refer to Figure 2 as you complete the following steps to install the cable adapter:

1. Insert the cable into the cable adapter.
2. Tighten the cable jackscrews.



Caution Before attaching any cables or accessories, install the NI high-speed DIO device. Refer to the Getting Started Guide that shipped with your device for instructions on installing the device.

Removing the NI 653x Cable Adapter from its Enclosure

You will need to remove the NI 653x cable adapter from its enclosure to connect signals. To remove the cable adapter from its enclosure, complete the following steps:

1. Remove the screws from the cable adapter enclosure top cover, as shown in Figure 3.

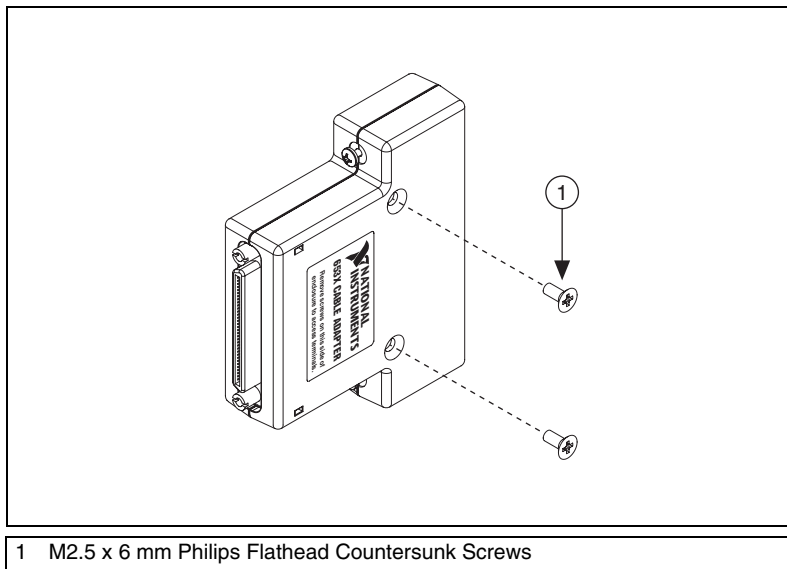

Figure 3. Remove Screws from the Enclosure

2. Remove the enclosure top cover.



Note Be sure to remove the screws from side with the NI logo label, as shown in Figure 3.

Connecting Signals

The NI 653x cable adapter provides connectivity to up to 32 of the single-ended DIO channels of an NI high-speed DIO device. Each DIO, PFI, and clock channel of the NI high-speed DIO device connects to a corresponding pin on the NI 653x cable adapter. The 32 DIO channels are directly connected between the two bulk connectors. PFI <0..5> from the NI 6535/6536/6537 VHDCI connector are connected to a 6-position screw terminal. PFI <0..7> from the NI 6533/6534 68-pin DAQ connector are connected to an 8-position screw terminal.

PFI channels must be manually connected through screw terminals for flexibility and to ensure correct signal routing. You can make connections between the PFI channels using 22- to 26-gauge wire.

The NI 6533/6534 devices have specific applications for PFI channels and thus require custom wiring to be compatible. An example of how to make these connections is provided in the [Custom Wiring Example](#) section.

Figure 4 shows the screw terminal locations on the NI 653x cable adapter.

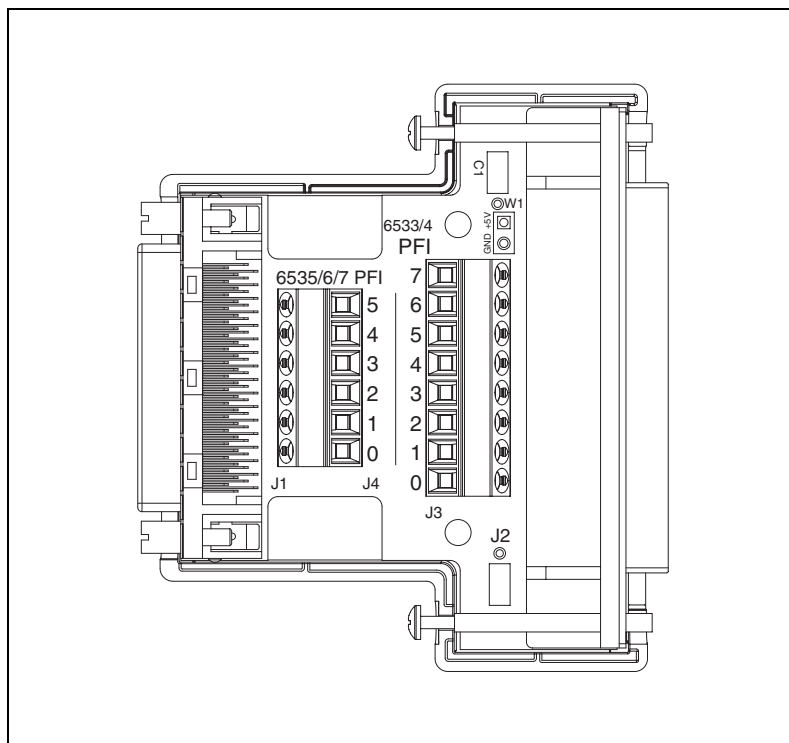

Figure 4. NI 653x Signal Connections



Note Refer to the help file for your device for information about the number of available DIO channels on your device. DIO <20..31> or PFI_0 may not be applicable to your device.

Figures 5 and 6 show pinouts for the VHDCI connector and 68-pin DAQ connector, respectively.

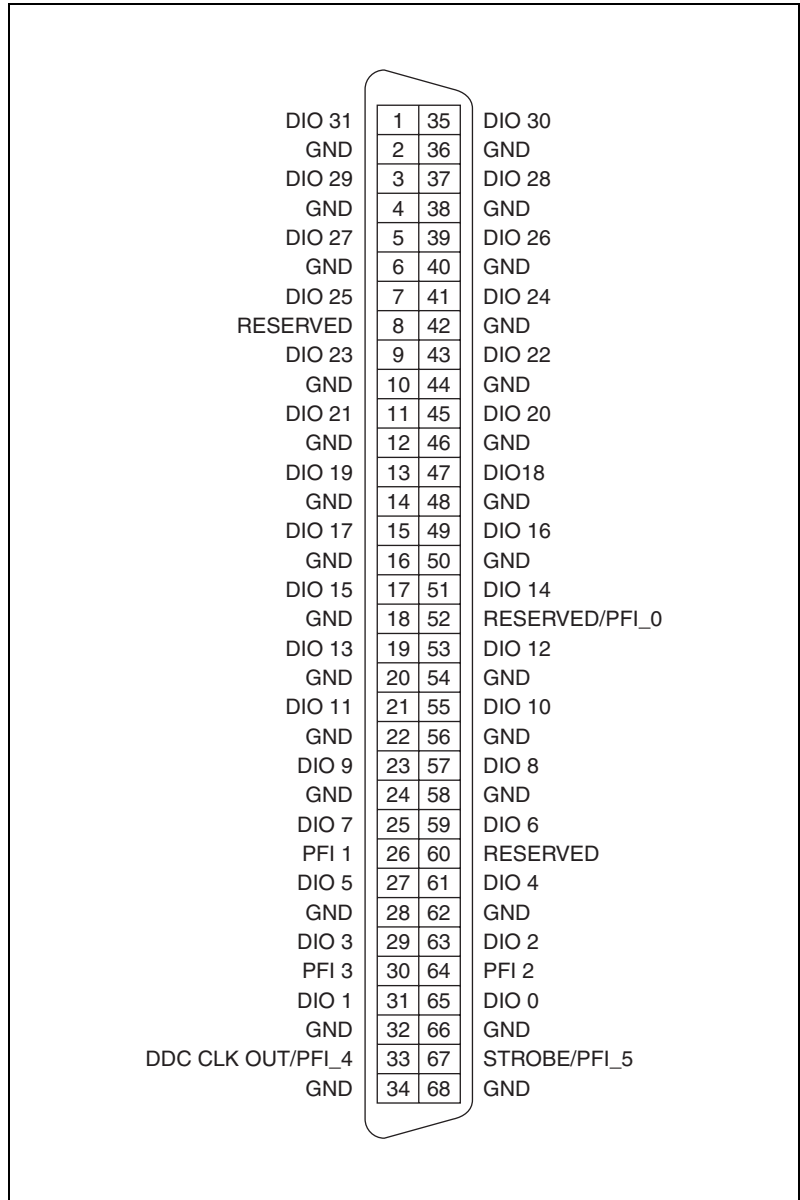

Figure 5. VHDCI Connector Pinout (NI SHC68-C68-D2 or NI C68-C68-D4 Cable)

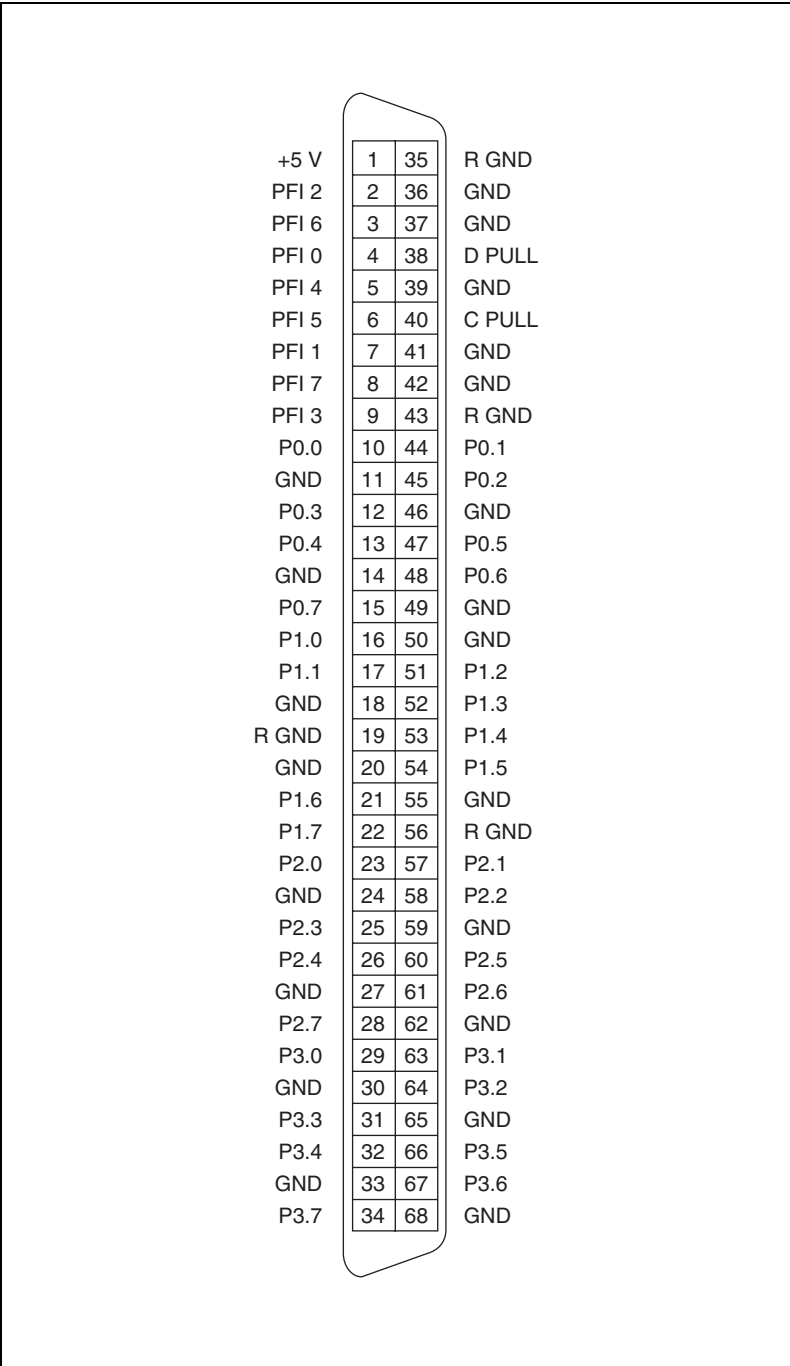

Figure 6. 68-pin DAQ Connector (NI 6533/6534 Fixture or Accessory)

Table 1 describes the VHDCI signals shown in Figure 5. Table 2 describes the DAQ connector signals shown in Figure 6.

Table 1. VHDCI Connector Pinout Descriptions (NI 6535/6536/6537/654x/655x)

Pin	Signal Description	Connection
DIO <0..31>	Bidirectional digital data channels 0 through 31.	P0 <0..7>, P1 <0..7>, P2 <0..7>, or P3 <0..7> on a 68-pin DAQ connector
PFI <0..5>	Programmable functional interface (PFI) channels 0 through 5.	6-position screw terminal (J4)
GND	Ground reference for signals.	—
RESERVED	These channels are reserved for system use. Do not connect signals to these channels.	—



Note Refer to your device documentation for supported channels.

Table 2. DAQmx Connector Pinout Descriptions (NI 6533/6534)

Pin	Signal Description	Connection
P0 <0..7>	Bidirectional digital data port 0 channels 0 through 7.	VHDCI DIO <0..7>
P1 <0..7>	Bidirectional digital data port 1 channels 0 through 7.	VHDCI DIO <8..15>
P2 <0..7>	Bidirectional digital data port 2 channels 0 through 7.	VHDCI DIO <16..23>
P3 <0..7>	Bidirectional digital data port 3 channels 0 through 7.	VHDCI DIO <24..31>
PFI <0..7>	Programmable functional interface (PFI) channels 0 through 7.	8-position screw terminal (J3)
+ 5 V	DC power	Unpopulated W1
C PULL, D PULL	Power on state control	NC



Note The NI 6535/6536/6537/654x/655x does not provide +5 V. If your fixtures require this, access to the +5 V signal on the DAQ connector is provided through the unpopulated W1 through-hole solder pad.



Caution Connections that exceed any of the maximum ratings for the NI 653x cable adapter or the NI high-speed DIO device can damage the device and the computer. Maximum input ratings are provided in the *Specifications* section and in the specifications document that shipped with the NI high-speed DIO device. NI is *not* liable for any damage resulting from such signal connections.

Table 3 shows the relationship between PFI channels and the termination sockets.

Table 3. PFI Screw Terminals

Connector	Channel	Socket
VHDCI (NI 6535/6536/6537/654x/655x)	PFI <0..5>	J4
68-Pin DAQ Connector (NI 6533/6534)	PFI <0..7>	J3



Note Refer to the help file for your device for information about the number of available DIO channels on your device. DIO <20..31> or PFI_0 may not be applicable to your device.

Custom Wiring Example

You can use different wiring schemes to connect the PFI channels in multiple configurations. This section describes a burst handshaking example using an NI 653x cable adapter to provide compatibility between an NI 6533/6534 and an NI 6535/6536/6537 where the fixture is configured to work with the NI 6533/6534. Without changing the fixture setup, the adapter and software can be changed to maintain functionality.

The NI 653x cable adapter can be configured using 22- to 26-gauge wire as shown in Figure 7.

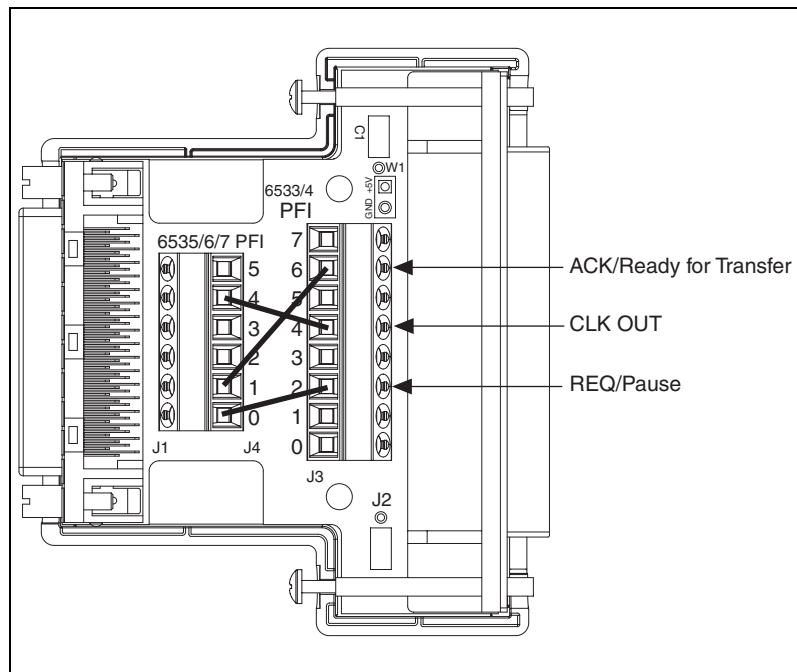

Figure 7. Example Connectivity

This custom wiring results in the signal assignments shown in the following table.

Table 4. Example Connections

VHDCI NI 6535/6536/6537	68-Pin DAQ NI 6533/6534
PFI_0	PFI_2 (REQ/Pause)
PFI_1	PFI_6 (ACK/Ready for Transfer)
PFI_4	PFI_4 (CLK OUT)

Specifications

Digital I/O

VHDCI DIO channels.....	32, single-ended
VHDCI control channels.....	6, single-ended
DAQ DIO channels.....	32, single-ended
DAQ control channels.....	8, single-ended

Traces

Type	Matched length to 100 mils
AC impedance.....	50 Ω

Power

Maximum voltage rating.....	5.5 V
-----------------------------	-------

Physical

Dimensions.....	62.7 \times 69.3 \times 16.7 mm (2.47 \times 2.73 \times 0.66 in.)
I/O connectors.....	68-pin VHDCI connector, 6 position screw terminal, 8 position screw terminal, 68-pin DAQ connector
Recommended wire gage.....	22-26 AWG
Recommended torque for screw terminals.....	0.3 N-m (2.7 lb-in)
Recommended torque for cover screws	0.23 N-m (2.0 lb-in)
Weight.....	60 g (2.1 oz)



Caution When connected to other test objects, this product may cause radio interference. In a residential environment, the user may be required to take adequate measures to reduce the radio interference.

Where to Go for Support

The National Instruments Web site is your complete resource for technical support. At ni.com/support you have access to everything from troubleshooting and application development self-help resources to email and phone assistance from NI Application Engineers.

National Instruments corporate headquarters is located at 11500 North Mopac Expressway, Austin, Texas, 78759-3504. National Instruments also has offices located around the world to help address your support needs. For telephone support in the United States, create your service request at ni.com/support and follow the calling instructions or dial 512 795 8248. For telephone support outside the United States, contact your local branch office:

Australia 1800 300 800, Austria 43 0 662 45 79 90 0,
Belgium 32 0 2 757 00 20, Brazil 55 11 3262 3599,
Canada 800 433 3488, China 86 21 6555 7838,
Czech Republic 420 224 235 774, Denmark 45 45 76 26 00,
Finland 385 0 9 725 725 11, France 33 0 1 48 14 24 24,
Germany 49 0 89 741 31 30, India 91 80 41190000,
Israel 972 0 3 6393737, Italy 39 02 413091, Japan 81 3 5472 2970,
Korea 82 02 3451 3400, Lebanon 961 0 1 33 28 28,
Malaysia 1800 887710, Mexico 01 800 010 0793,
Netherlands 31 0 348 433 466, New Zealand 0800 553 322,
Norway 47 0 66 90 76 60, Poland 48 22 3390150,
Portugal 351 210 311 210, Russia 7 095 783 68 51,
Singapore 1800 226 5886, Slovenia 386 3 425 4200,
South Africa 27 0 11 805 8197, Spain 34 91 640 0085,
Sweden 46 0 8 587 895 00, Switzerland 41 56 200 51 51,
Taiwan 886 02 2377 2222, Thailand 662 278 6777,
United Kingdom 44 0 1635 523545

National Instruments, NI, ni.com, and LabVIEW are trademarks of National Instruments Corporation. Refer to the *Terms of Use* section on ni.com/legal for more information about National Instruments trademarks. Other product and company names mentioned herein are trademarks or trade names of their respective companies. For patents covering National Instruments products, refer to the appropriate location: **Help»Patents** in your software, the `patents.txt` file on your CD, or ni.com/patents.