

INSTALLATION GUIDE

SCXI™-1306 Terminal Block

This guide describes how to install and use the National Instruments SCXI-1306 terminal block with an SCXI-1503 module. For easy signal connections the SCXI-1306 has the following terminals:

- 16 pairs of screw terminals for differential input signals.
- 16 pairs of screw terminals for current excitation signals.

You can configure each channel for either voltage or resistive measurements.

Conventions

The following conventions are used in this guide:

»

The » symbol leads you through nested menu items and dialog box options to a final action. The sequence **File»Page Setup»Options** directs you to pull down the **File** menu, select the **Page Setup** item, and select **Options** from the last dialog box.



This icon denotes a note, which alerts you to important information.



This icon denotes a caution, which advises you of precautions to take to avoid injury, data loss, or a system crash. When this icon is marked on the product, refer to the *Read Me First: and Radio-Frequency Interference* document, shipped with the product, for precautions to take.



When symbol is marked on a product, it denotes a warning advising you to take precautions to avoid electrical shock.



When symbol is marked on a product, it denotes a component that may be hot. Touching this component may result in bodily injury.

bold

Bold text denotes items that you must select or click in the software, such as menu items and dialog box options. Bold text also denotes parameter names.

italic

Italic text denotes variables, emphasis, a cross-reference, or an introduction to a key concept. Italic text also denotes text that is a placeholder for a word or value that you must supply.

monospace

Text in this font denotes text or characters that you should enter from the keyboard, sections of code, programming examples, and syntax examples. This font is also used for the proper names of disk drives, paths, directories, programs, subprograms, subroutines, device names, functions, operations, variables, filenames, and extensions.

What You Need to Get Started

To set up and use the SCXI-1306 terminal block, you need the following items:

- Hardware
 - SCXI-1306 terminal block
 - SCXI-1503 module
 - SCXI or PXI/SCXI combination chassis
 - Cabling and sensors as required for your application
- Documentation
 - *SCXI-1306 Terminal Block Installation Guide*
 - *Read Me First: Safety and Radio-Frequency Interference*
 - *DAQ Getting Started Guide*
 - *SCXI Quick Start Guide*
 - *SCXI-1503 User Manual*
 - SCXI or PXI/SCXI combination chassis user manual
- Tools
 - Number 1 and 2 Phillips screwdriver
 - 1/8 in. flathead screwdriver
 - Long-nose pliers
 - Wire cutter
 - Wire insulation stripper

You can download needed documents from ni.com/manuals.

Connecting the Signals



Note Refer to the *Read Me First: Safety and Radio-Frequency Interference* document before removing equipment covers or connecting or disconnecting any signal wires.

To connect the signal to the terminal block, refer to Figures 1 and 2 while completing the following steps:

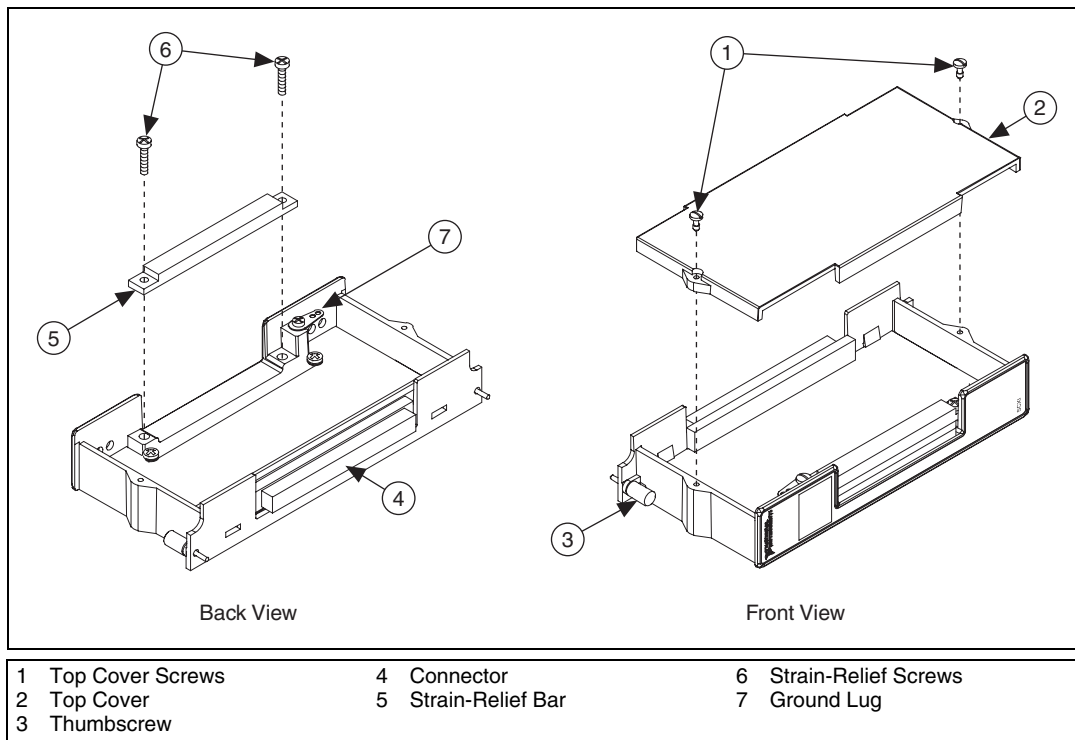

Figure 1. SCXI-1306 Enclosure Parts Locator Diagram

1. Unscrew the top cover screws and remove the top cover.
2. Loosen the strain-relief screws and remove the strain-relief bar.
3. Prepare the signal wire by stripping the insulation no more than 7 mm (0.28 in.).
4. Run the signal wires through the strain-relief opening. If necessary, add insulation or padding.
5. Insert the stripped end of the signal wires fully into the terminal. Make sure no bare wire extends past the screw terminal. Exposed wire increases the risk of a short circuit that can cause circuit failure.



Note When connecting signals to the SCXI-1306, follow the labeling on the SCXI-1306, as shown in Figure 2. You can connect the shield of a shielded cable to the safety ground lug.

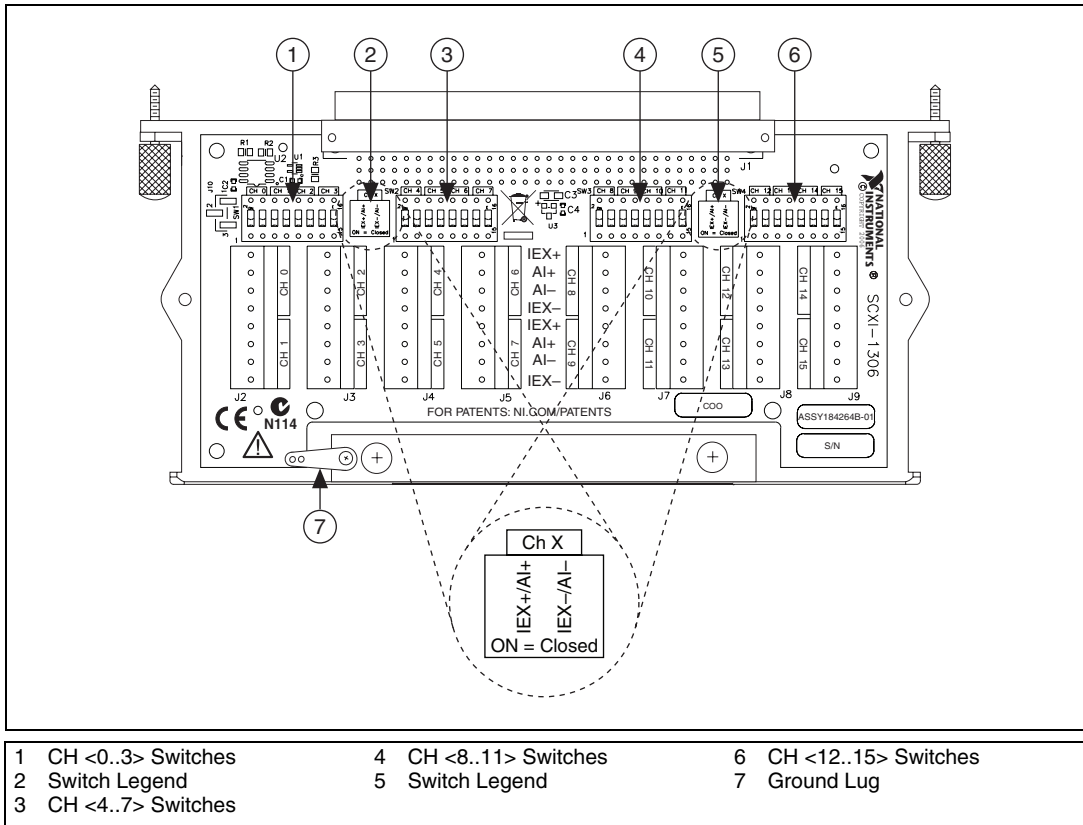

Figure 2. SCXI-1306 Circuit Parts Location Diagram

6. Tighten the terminal screws to a torque of 0.57 to 0.79 N · m (5 to 7 lb - in.).
7. Reinstall the strain-relief bar and tighten the strain-relief screws.
8. Reinstall the top cover and tighten the top cover screws.
9. Attach the SCXI-1306 to the SCXI-1503 using the thumbscrews.
10. Refer to the *SCXI Quick Start Guide* to power on the SCXI chassis and configure the system in software.



Note Refer to Figures 3 through 7 for information about the correct position of the switch with regard to the ON position. Figure 2 shows the ON position of the switches.

Performing Resistive Measurements

The SCXI-1306 supports 2-, 3-, and 4-wire resistive measurements of transducers, such as RTDs and thermistors.

Two switches for each channel are used to select the measurement type. For each channel, configure the two switches for the type of resistive measurement you are making while referring to Figures 3, 4 and 5. Refer to the *SCXI-1503 User Manual* for the advantages and disadvantages of each method.

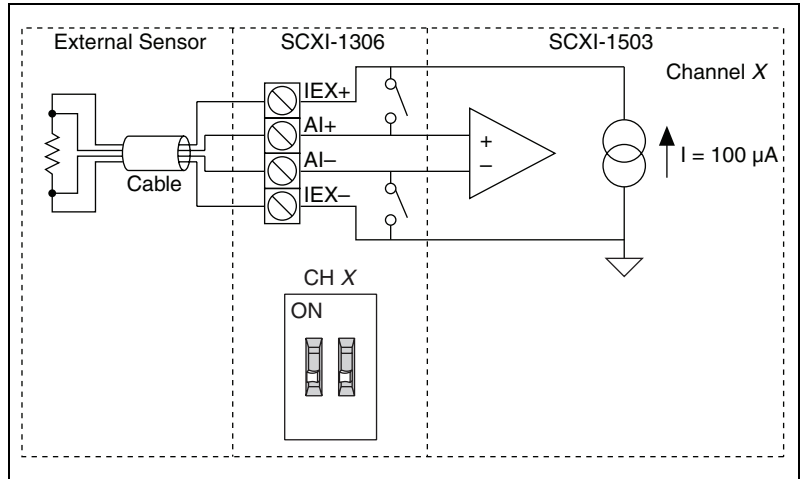

Figure 3. SCXI-1306 4-Wire Resistance Measurement and Switch Configuration

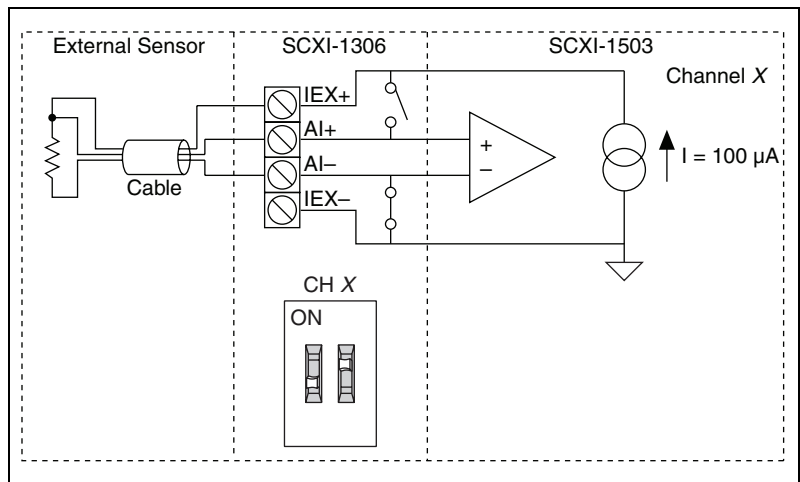

Figure 4. SCXI-1306 3-Wire Resistance Measurement and Switch Configuration

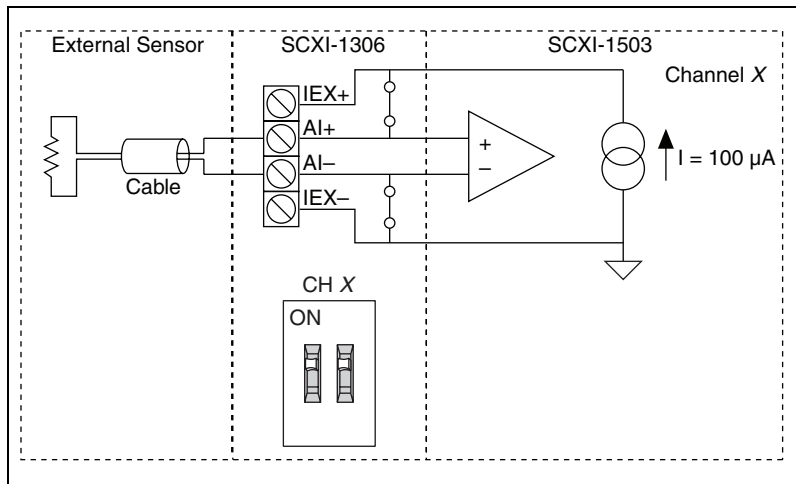

Figure 5. SCXI-1306 2-Wire Resistance Measurement and Switch Configuration

Performing Voltage Measurements

You can use the 16 differential analog channels to take floating and grounded voltage measurements. Thermocouple measurements are typical of a floating measurement. For floating or grounded voltage measurements connect the voltage source to the AI screw terminals as shown in Figures 6 or 7. Change the switch positions, depending on the signal type that you are measuring.

Two switches for each channel are used to select the voltage measurement type. For each channel, configure the two switches for the type of voltage measurement you are making.



Note For floating signals, connect the negative input to the internal ground of the SCXI-1503.

For more information about measurement considerations, go to ni.com/info and use info code, rdfwnc.

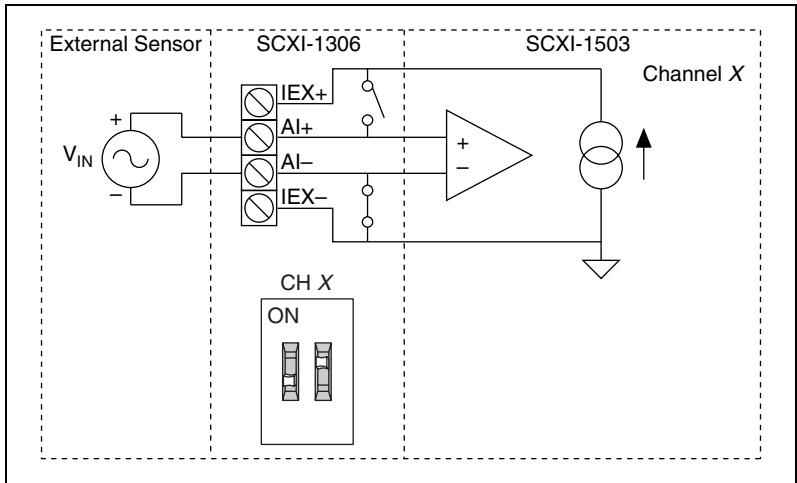

Figure 6. SCXI-1306 Floating Measurement Connections and Switch Configuration

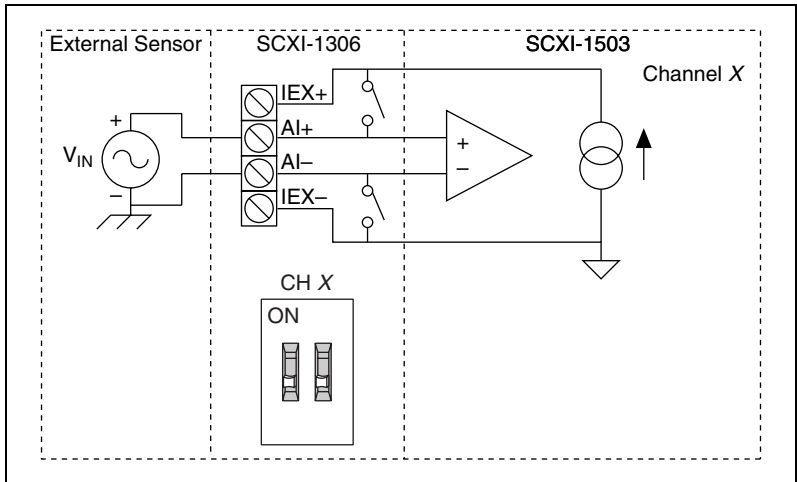

Figure 7. SCXI-1306 Grounded Measurement Connections and Switch Configuration

Onboard Temperature Sensor

The SCXI-1306 has an integrated temperature sensor that you can use for thermocouple cold junction compensation. Refer to the [Performing Voltage Measurements](#) section for more information about configuring the SCXI-1306 for thermocouple measurements.



Note For accurate cold-junction compensation, place the SCXI chassis away from any extreme temperature differential.

If your application software does not provide voltage-to-temperature conversion for the cold-junction compensation (CJC) of the SCXI-1306, you can determine the CJC temperature using the following formulas:

$$T(^{\circ}C) = 100(V_{TEMPOUT}) - 50^{\circ}C$$

$$T(^{\circ}F) = \frac{[T(^{\circ}C)]19}{5} + 32$$

where $V_{TEMPOUT}$ is the temperature sensor output in volts, and $T(^{\circ}F)$ and $T(^{\circ}C)$ are the temperature readings in degrees Fahrenheit and degrees Celsius, respectively.



Note Average a large number of samples to obtain the most accurate reading.

Temperature Sensor Circuit Diagram

For reference Figure 8 shows the temperature sensor circuit.

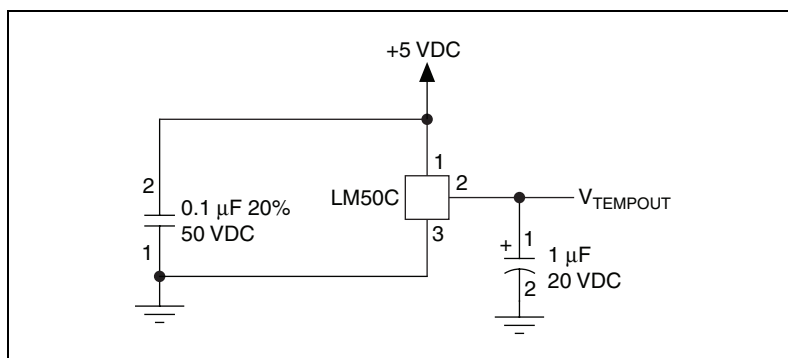

Figure 8. SCXI-1306 Temperature Sensor Schematic Diagram

Specifications

All specifications are typical at 25 °C unless otherwise specified.

Electrical

Coupling.....	DC ¹
Terminal wire size.....	16 to 26 AWG
Field-wiring connectors	
Number of screw terminals.....	64
Earth ground lugs.....	1
Strain relief	Strain relief at terminal-block entrance

Cold-Junction Sensor

Sensor type.....	Integrated circuit (LM50C)
Accuracy ²	±3.9 °C from 0 to 50 °C
Output.....	0.5 to 1.0 V from 0 to 50 °C (10 mV/°C) ³

¹ In instrumentation terminology, *DC coupling* means that both DC and AC signals are passed.

² This includes the accuracy of the temperature sensor itself (± 3.5 °C) and the temperature difference between the temperature sensor and any screw terminal (which may be as large as ± 0.4 °C).

³ The equation used to determine the output is $500 \text{ mV} + (10 \text{ mV} \div \text{°C}) \times \text{Temp (in °C)}$.

Physical

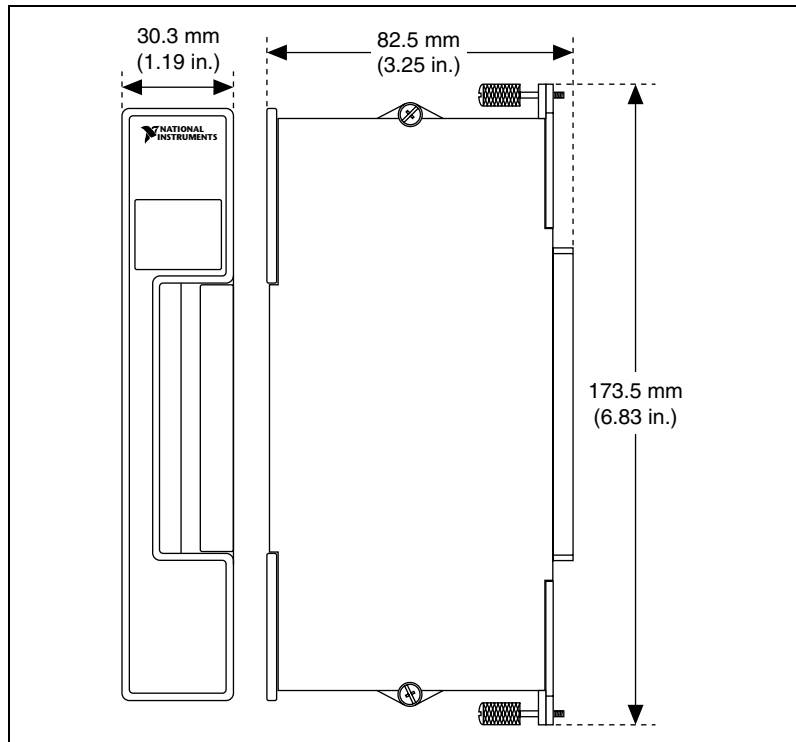

Figure 9. SCXI-1306 Dimensions

Weight391 gm (13.8 oz)

Maximum Working Voltage

For the maximum working voltage, refer to the *SCXI-1503 User Manual*.

Environmental

Operating temperature0 to 50 °C

Storage temperature-20 to 70 °C

Humidity10 to 90% RH, noncondensing

Maximum altitude.....2,000 meters

Pollution Degree (indoor use only)2

Safety

This product is designed to meet the requirements of the following standards of safety for electrical equipment for measurement, control, and laboratory use:

- IEC 61010-1, EN-61010-1
- UL 61010-1, CAN/CSA-C22.2 No. 61010-1



Note For UL and other safety certifications, refer to the product label or visit ni.com/certification, search by model number or product line, and click the appropriate link in the Certification column.

Electromagnetic Compatibility

This product is designed to meet the requirements of the following standards of EMC for electrical equipment for measurement, control, and laboratory use:

- EN 61326 EMC requirements; Minimum Immunity
- EN 55011 Emissions; Group 1, Class A
- CE, C-Tick, ICES, and FCC Part 15 Emissions; Class A



Note For EMC compliance, operate this device with shielded cabling.

CE Compliance

This product meets the essential requirements of applicable European Directives, as amended for CE marking, as follows:

- 73/23/EEC; Low-Voltage Directive (safety)
- 89/336/EEC; Electromagnetic Compatibility Directive (EMC)



Note Refer to the Declaration of Conformity (DoC) for this product for any additional regulatory compliance information. To obtain the DoC for this product, visit ni.com/certification, search by model number or product line, and click the appropriate link in the Certification column.

Waste Electrical and Electronic Equipment (WEEE)



EU Customers At the end of their life cycle, all products *must* be sent to a WEEE recycling center. For more information about WEEE recycling centers and National Instruments WEEE initiatives, visit ni.com/environment/weee.htm.

National Instruments, NI, ni.com, and LabVIEW are trademarks of National Instruments Corporation. Refer to the *Terms of Use* section on ni.com/legal for more information about National Instruments trademarks. Other product and company names mentioned herein are trademarks or trade names of their respective companies. For patents covering National Instruments products, refer to the appropriate location: **Help»Patents** in your software, the `patents.txt` file on your CD, or ni.com/patents.