

NI PXI-4022 Specifications

Guard and Current Amplifier

This document lists the specifications for the NI PXI-4022 guard and current amplifier module. The NI 4022 is an accessory PXI module that consists of a high-speed, high-precision amplifier that conditions signals for acquisition by measurement devices. This document also contains information on how to use and program the module.

Contents

Getting Started	2
Related Documentation.....	2
System Requirements	2
Installing the Software	2
Installing the Hardware.....	3
Connecting Signals	3
Programming	4
NI 4022 Applications	5
6-Wire Guarded Measurements	7
Considerations on R_1 , R_2 , and R_3 when Making Guarded Measurements	9
Low-Current Measurements	10
Low-Current Measurement Considerations.....	13
Specifications	14
Guard Amplifier.....	14
Current Amplifier	14
Input Characteristics	14
Output Characteristics.....	14
General Specifications	15
Environment.....	15
Operating Environment	15
Storage Environment	16
Shock and Vibration	16

Safety, Electromagnetic Compatibility, and CE Compliance	16
Safety	16
Electromagnetic Compatibility.....	17
CE Compliance.....	17
Waste Electrical and Electronic Equipment (WEEE)	17
Where to Go for Support	18

Getting Started

Related Documentation

The following documents contain information you might find helpful when using the NI 4022:

- *NI Digital Multimeters Help*
- *NI Digital Multimeters Getting Started Guide*
- *NI-DMM Readme*
- *Read Me First: Safety and Radio-Frequency Interference*

You can find most of these documents by installing NI-DMM and then selecting **Start»Programs»National Instruments»NI-DMM»Documentation**. The document *Read Me First: Safety and Radio-Frequency Interference* is shipped in the hardware kit.

System Requirements

The system requirements for using the NI 4022 module are the same as for using any NI digital multimeter. For detailed information, refer to the *NI Digital Multimeters Getting Started Guide* or the *NI-DMM Readme* (version 2.5 or later).

Application Development Environment (ADE)

You must use LabVIEW 7.1 or later to operate the NI 4022. C programming is not currently supported for this module.

Installing the Software

Install LabVIEW if you have not already done so, then install NI-DMM 2.5 or later as described in the *NI Digital Multimeters Getting Started Guide*.

Installing the Hardware



Note LabVIEW and NI-DMM software must be installed *before* you install the NI 4022 hardware.

Install the NI 4022 module into an empty slot in your PXI chassis and configure the module in Measurement & Automation Explorer (MAX). Refer to the *NI Digital Multimeters Getting Started Guide* for instructions on installing and configuring PXI modules.

Connecting Signals

The front panel of the NI 4022 has five color-coded banana connectors. The two black connectors are electrically equivalent and represent the floating ground of the module. The connectors are arranged to simplify wiring as much as possible. Table 1 lists the colors and descriptions of the connectors.

Table 1. NI 4022 Front Panel Signal Connections

Color	Description
Blue	Guard/amplifier output
Black	Floating common (LO)
Red	Guard/amplifier positive input
Black	Floating common (LO)
Red	Guard-Sense/amplifier negative input

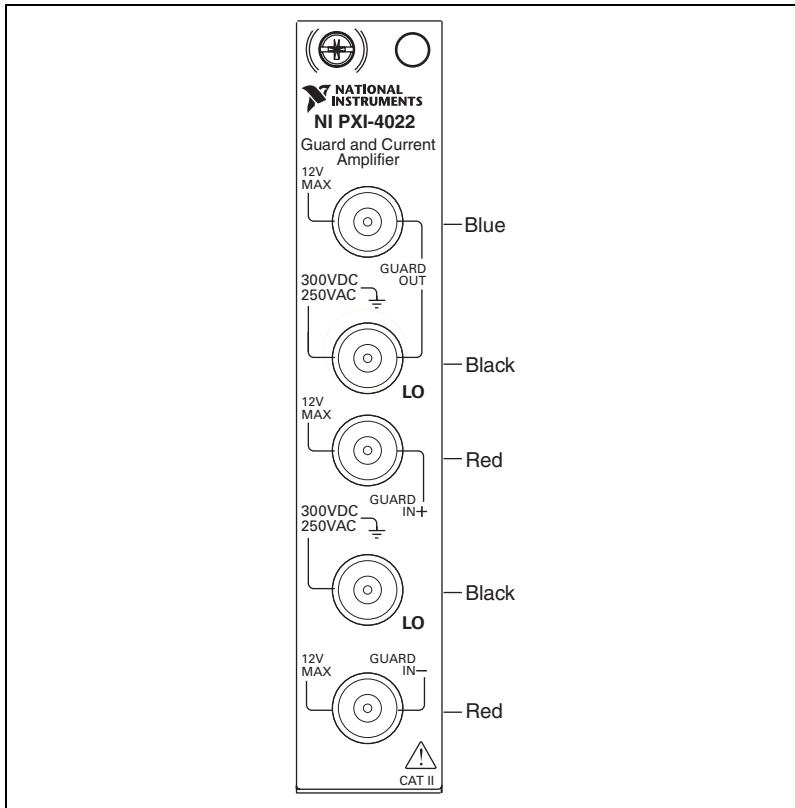
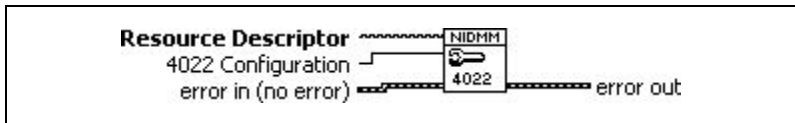

Figure 1. NI 4022 Front Panel

Programming

To operate the NI 4022 module, use the niDMM 4022 Control VI, which is located on the **NI-DMM»Utility** palette in LabVIEW. The following figure shows the connector pane for the VI.



The **Resource Descriptor** parameter contains the name of the device, which is assigned by MAX. The **4022 Configuration** parameter specifies the operating mode of the module. For more information on available operating modes, refer to the LabVIEW context help for the **4022 Configuration** parameter by pressing <Ctrl-H>.

NI 4022 Applications

The primary measurement device described in this document is a digital multimeter (DMM). DMMs offer the accuracy and measurement types needed to fully exercise the feature set of the NI 4022.



Note You can use other types of measurement devices, such as an oscilloscope, by using a banana-to-BNC adapter for connections.



Caution Observe all voltage ratings and safety warnings when using devices with differing specifications. For example, if you use a measurement device that is only specified to a maximum common-mode voltage of 60 VDC, do not exceed that voltage into the NI 4022. The NI 4022 is rated to 250 VAC/300 VDC Cat II, which also applies to many DMM devices.

The basic structure of the NI 4022 is a unity gain amplifier that can also function as a preamplifier for making low-level current measurements. Figure 2 is a block diagram for the guard mode showing the circuit relative to the input and output connectors. Figure 3 shows the block diagram for the current amplifier mode.

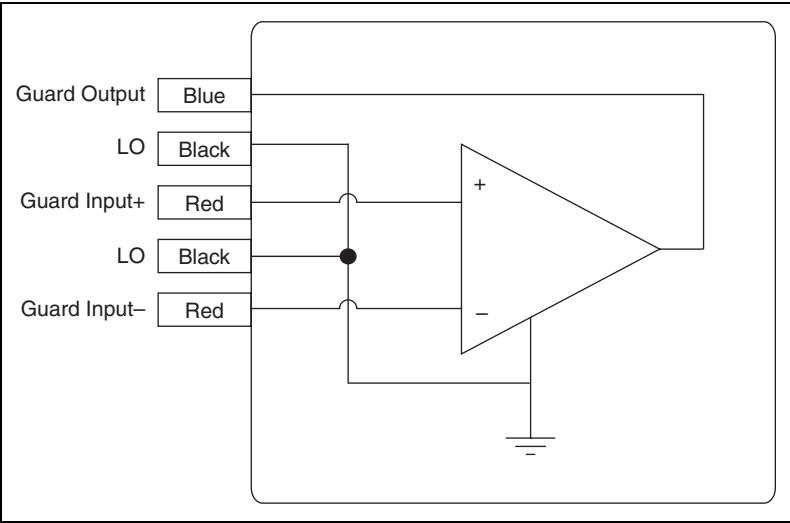

Figure 2. NI 4022 Guard Mode

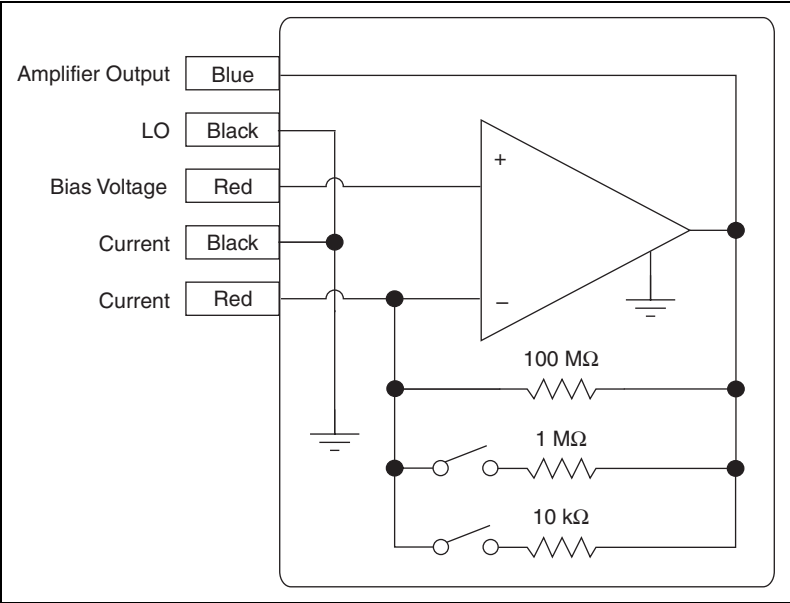

Figure 3. NI 4022 Current Amplifier Mode

6-Wire Guarded Measurements

The default configuration of the NI 4022 is a guard amplifier, which configures the NI 4022 as a unity gain buffer. One of the most common applications for the NI 4022 as a guard amplifier is measuring a single resistor in a network of series and parallel resistors. Use the NI 4022 in conjunction with the 4-wire ohms measurement of the DMM to make an accurate measurement of the resistor of interest.

For a 4-wire measurement, the HI/HI Sense and LO/LO Sense lines should make a Kelvin connection as close to the network as possible. Refer to the *NI Digital Multimeters Help* for more information about 4-wire measurements.

Figure 4 shows how to connect the DMM and NI 4022 to the resistor network to accurately measure resistance R_1 . Figure 5 shows how to connect the DMM and the NI 4022 in a similar fashion to measure capacitance C_1 . If the DMM supports 4-wire capacitance measurements, or the capacitance meter supports 4-wire measurements, refer to Figure 5. If you are using a DMM that supports 2-wire capacitance measurements (for example, the NI 4072), there is no need to connect the HI Sense and LO Sense lines of the meter to the network. You can use cable compensation techniques to null the effects of the network cabling. Refer to the *NI Digital Multimeters Help* for more information about using cable compensation with the NI 4072.

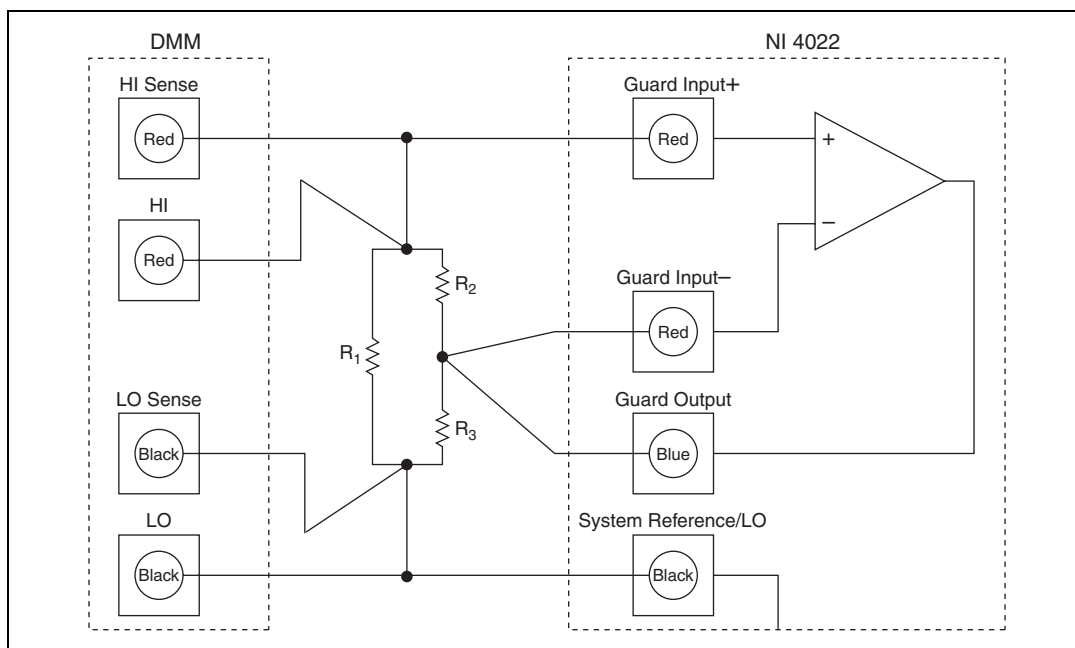

Figure 4. NI 4022 and DMM Connections (Resistors)

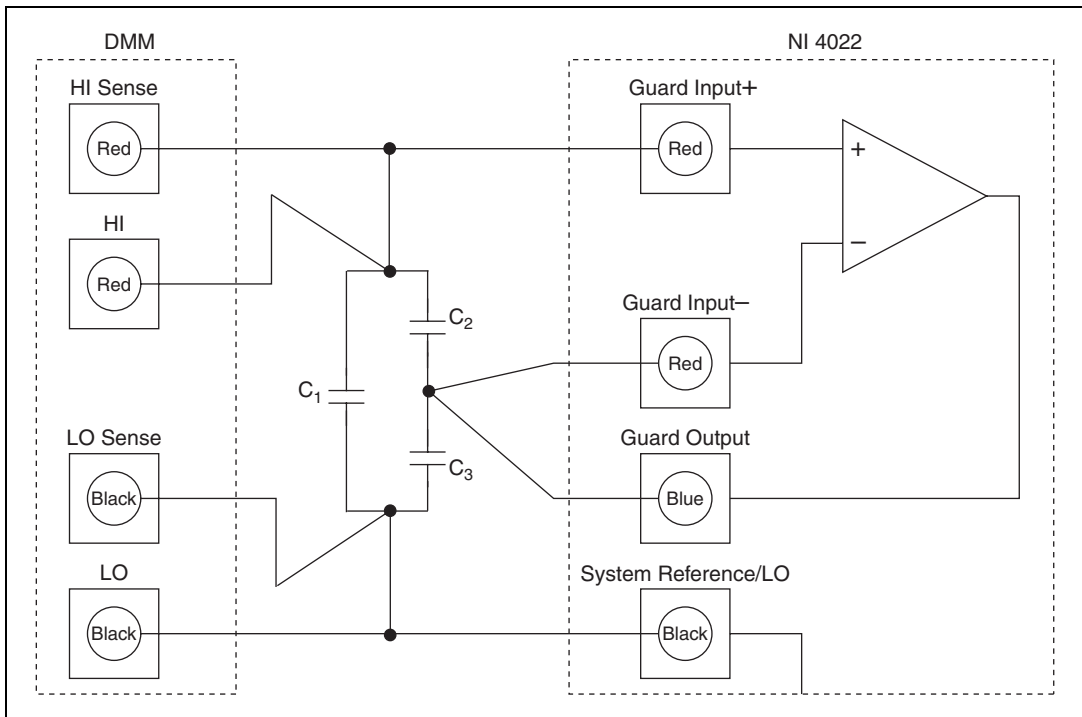

Figure 5. NI 4022 and DMM Connections (Capacitors)

The configuration shown in Figure 4 uses the NI 4022 to apply a voltage between resistor R_2 and resistor R_3 that is equal to the voltage across R_1 . This applied voltage causes a voltage drop of zero across resistor R_2 . Thus, no current from the DMM flows through the network leg consisting of resistors R_2 and R_3 , effectively canceling the effects of these resistors from the measurements. A voltage exists across resistor R_3 equal to the voltage across resistor R_1 , but that current is being supplied by the guard amplifier. The same theory applies when the network consists of capacitors.

The Guard Input and Guard Output lines from the NI 4022 are the additional two lines that comprise the 6-wire measurement. It is very important to connect the four wires from the DMM to the network as close as possible to the network itself. The HI Sense line of the DMM and the Guard Input of the NI 4022 are high-impedance paths, therefore their connection can be made close to the DMM and NI 4022 and away from the network. The same principle applies for the connection of the two LO terminals. This connection is required because both the DMM and the NI 4022 are floating, so they must share a common reference. The Guard Input- and the Guard Output lines from the NI 4022 can be long, but they must be tied together at the network.

Considerations on R_1 , R_2 , and R_3 when Making Guarded Measurements

The resistance of interest R_1 dictates the mode and range used on the DMM. This along with the expected value of R_1 determines the voltage that is driven across R_1 . To ensure proper operation of the NI 4022, use this voltage value to calculate the minimum possible resistance of R_3 . For example, if R_1 is 1 k Ω and is being measured on the 1k Ω range, the test current is 1 mA and generates a voltage of 1 V across R_1 (refer to the DMM specifications for Test Current and Voltage). This same voltage appears across R_3 when used with the NI 4022. The NI 4022 has a maximum guard-output current of 15 mA. Therefore, the minimum value of R_3 that can be guarded out without causing error is 1 V/15 mA, or 67 Ω . If you need to guard out smaller values of R_3 , consider putting the DMM in the 10 k Ω range, which decreases the test voltage to 100 μ V and the minimum value of R_3 by 10 to about 7 Ω . The trade-off is that the measurement error of R_1 increases as the values of R_2 and R_3 decrease.

The offset of the guard amplifier contributes error when the value of R_2 is small. The offset voltage of the guard amplifier is applied directly across R_2 and the resulting current is subtracted from the calibrated test current from the DMM (which is meant to flow through R_1), causing an error. For example, in the case above measuring a 1 k Ω resistor on the 1 k Ω range, if R_2 is 100 Ω and the typical offset voltage is 200 μ V, the error in the test current is 200 μ V/100 Ω , or 0.002 mA, which steals 0.2% of the 1 mA test current. This results in a measurement error on R_1 of 0.2%.

These additional errors are straightforward to calculate and must be added to the total system error.

Guarding measurements are required for many in-circuit test applications. The population of the printed circuit board can sometimes mean that you cannot directly measure the component of interest. You can use guarding to isolate the component for proper measurement. In some cases, multiple points must be guarded. In these cases, use multiple NI 4022 modules to generate the voltages necessary to guard against other components.

When measuring capacitors in a network, use the graph shown in Figure 6 to estimate the maximum amount of capacitance that can be guarded. The graph shows the ratio of the capacitor of interest (C_1) and the capacitance of the other capacitors (C_2 and C_3) in the network (refer to Figure 5 for a reference to C_1 , C_2 , C_3). The graph assumes that C_2 is equal to C_3 and that you are using the NI 4022 with an NI 4072 DMM to take the capacitance measurements. For example, if the capacitor network consists of capacitor C_1 equal to 1 μ F, then the maximum guarding ratio is 10. This ratio means that C_2 and C_3 cannot be more than 10 μ F to be effectively guarded out of the measurement of C_1 .

The two plots in Figure 6 reflect the change in ranges when using the NI 4072. The NI 4072 changes the current and frequency of the stimulus waveform for higher capacitor values. These changes affect the amount of capacitance the NI 4022 can guard, hence the discontinuity in the graph.

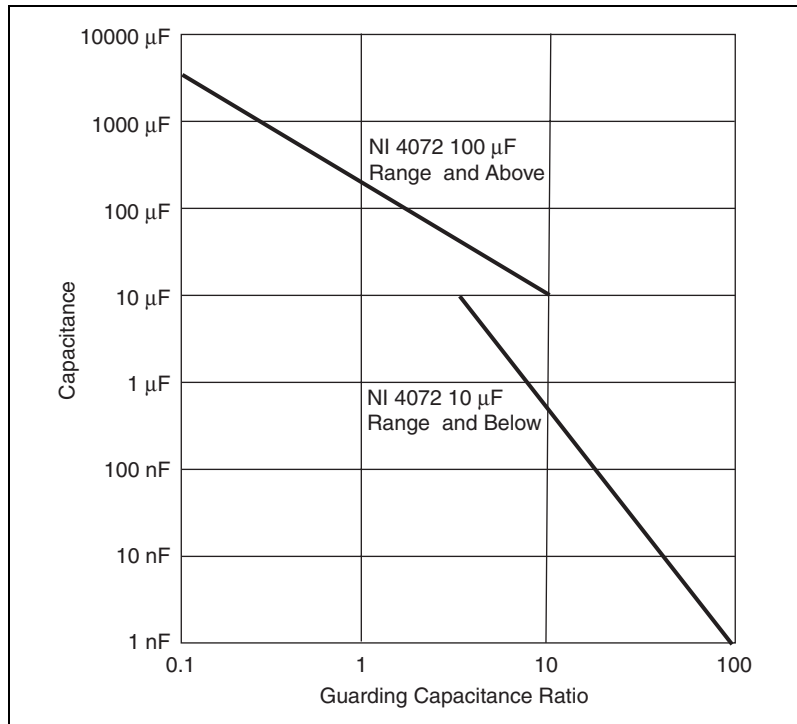

Figure 6. NI 4022 Guarding Capacitance Ratio

Low-Current Measurements

You can also use the NI 4022 as a low-current preamplifier. The NI 4022 uses the onboard amplifier and onboard high-precision resistors to create a feedback current amplifier. This configuration minimizes burden voltage and improves response time compared to a shunt-type configuration. The NI 4022 can measure picoamps with sub-picoamp noise.

The NI 4022 has three current ranges: 1 mA, 10 μA, and 100 nA. The current is amplified and converted to a voltage that varies linearly from 0 to ±10 V for each of the ranges from 0 amps to ± Full-Scale. The purpose of the amplifier is to return a current magnitude. The direction of the current appears inverted in polarity; you can remedy the inversion by multiplying the result by -1.

Figures 7 and 8 show how to connect the NI 4022 and DMM for a low-current measurement. R_f is the feedback resistor that is switched into the circuit depending on the range you select. R_f is 100 M Ω for the 100 nA range.

Offset of the amplifier is associated with this type of measurement, but you can easily measure this offset by disconnecting the current input. This configuration is the closest possible to zero current. You can subtract the corresponding output voltage from subsequent measurements to account for offset. The components used in the NI 4022 have a low temperature coefficient, so the offset value has negligible additional error within ± 5 °C from the temperature at which the offset measurement is taken. Be sure to fully warm up the instruments before taking the offset measurement.

In most feedback ammeter applications the positive input terminal of the amplifier is grounded. Figures 7 and 8 show the grounding switch S_1 . Figure 7 shows the configuration for a standard current measurement. The current applied between the LO and Guard In- input is converted to a voltage signal to be acquired by the DMM. Figure 8 shows the ability to take advantage of the isolation provided by both the DMM and the NI 4022 to apply an external bias voltage. The configuration of Figure 8 allows you to float the measurement devices on the external voltage. The voltage applied to the Guard In+ terminal appears at the Guard In- terminal across the device under test (DUT). Note the difference between the ground symbols on the diagram. The external voltage is earth ground referenced while the DMM and the NI 4022 are referenced to a floating ground. Do not exceed the maximum voltage ratings of the NI 4022 or the DMM when applying an external high voltage.

Some applications may require access to all of the guard amplifier terminals. This involves opening switch S_1 , which you can disconnect through software using the niDMM 4022 Control VI. Refer to the LabVIEW context help of the **4022 Configuration** control on the front panel of this VI for instructions. Disabling the grounding switch allows access to the Guard In+ terminal. The NI 4022 output amplifier has a useful dynamic range of approximately ± 10 V. You must consider this when using the guard amplifier in a general purpose amplifier configuration.

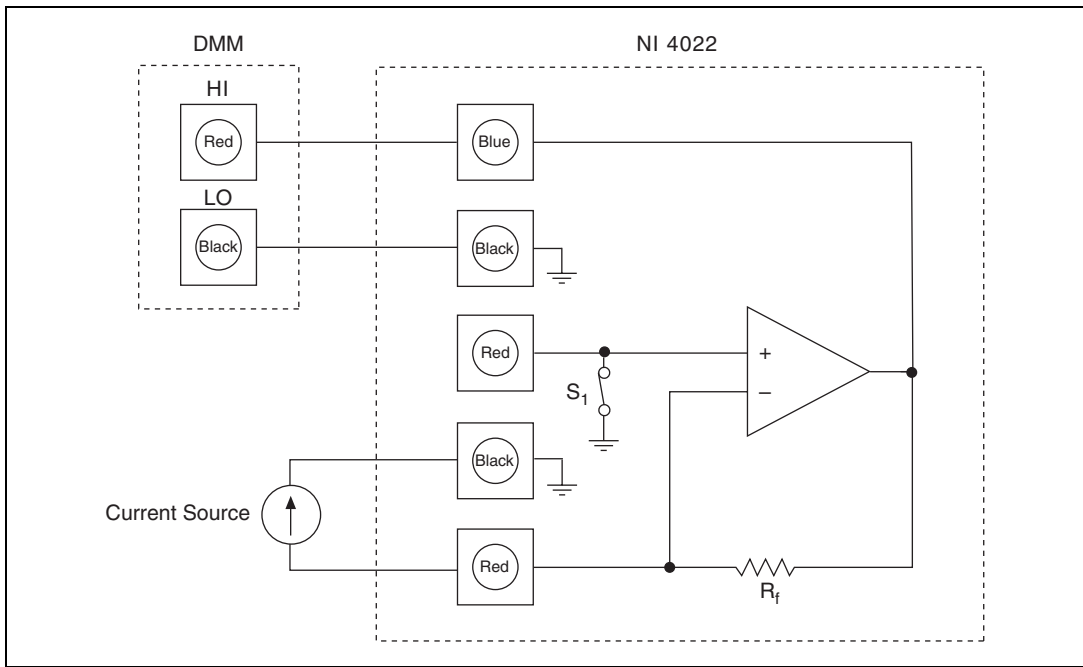

Figure 7. NI 4022 and DMM Connections for a Low-Current Measurement

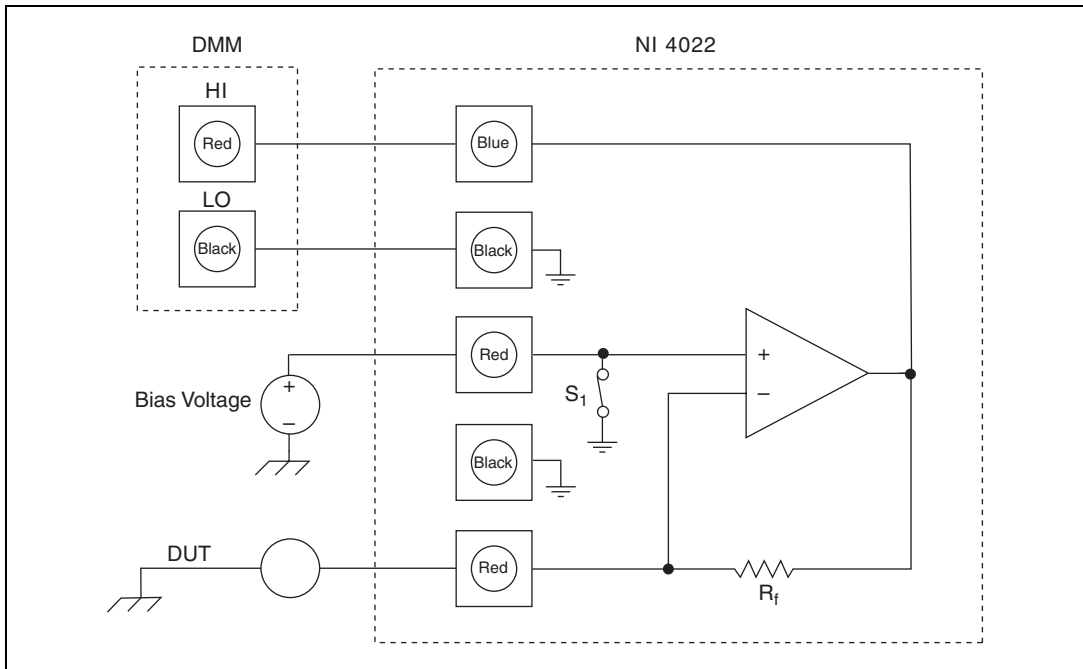

Figure 8. NI 4022 and DMM Connections for a Low-Current Measurement with External Bias

Low-Current Measurement Considerations

At the lowest range the NI 4022 is very sensitive to any changes in applied current. Great care must be taken with wiring to ensure maximum noise reduction and shielding.

Consider the following when making low-current measurements:

- 60 Hz noise pickup is the most common and considerable source of noise. You can reduce the effect of this noise by using proper cabling, including shielded cables and coaxial cables. Any noise that enters the NI 4022 and is amplified will be present at the output terminals of the module. Filtering is the preferred method of removing this 60 Hz component, and most DMMs handle 60 Hz noise rejection very well. At 6 ½ digit measurement speed the 60 Hz rejection is typically high enough to virtually eliminate the noise from the signal, allowing for confident and accurate readings.
- Triboelectric effects arise from the movement of a conductor against an insulator. Cables designed to minimize this effect are available. Reducing cable movement with tie-downs or other fixtures also minimizes this effect.
- Piezoelectric effects and leakage currents are also potential sources of error. Piezoelectric effects are caused by the physical deflection of an insulator. Reducing the amount of stress on a device helps to minimize this effect. Leakage currents are often the result of contaminants around the device of interest. These contaminants provide an additional current path that causes measurement error. Solder flux, fingerprints (oil, salt, and so on), can be sources of contamination. Many contaminants can be cleaned using rubbing alcohol or a similar solvent.

Refer to the *Low-Current Measurement Considerations* topic in the *NI Digital Multimeters Help* for more information about making low-level current measurements

Cables

Proper cabling and connectors are necessary to ensure accurate measurements. NI offers two cabling accessories that provide the components needed to make low-level measurements. The Low-Leakage, Low-Thermal Cable Set (part number 779410-01) consists of two high-impedance prefabricated cables, and the Low-Leakage, Low-Thermal Connectivity Set (part number 779499-01) consists of the components needed to make custom high-impedance cables. Refer to ni.com for more information about these cable kits. Other high-performance connectors, for example, banana-to-BNC, are available from third-party suppliers such as Pomona.

Specifications



Note All specifications in this document are subject to change without notice. For the most current specifications, visit ni.com/manuals.

Guard Amplifier

Input-Output offset $\pm 200 \mu\text{V}$ typical,
 $\pm 500 \mu\text{V}$ maximum

Input offset voltage drift $2 \mu\text{V}/^\circ\text{C}$

Gain $1 \pm 0.0005\%$ at DC

Slew rate $40 \text{ V}/\mu\text{s}$ minimum

Bandwidth 1 MHz minimum

Current Amplifier

Gain Setting V/A (Range)	Accuracy* $23^\circ\text{C} \pm 5^\circ\text{C}$	Usable Sensitivity†	Settling Time‡	Burden Voltage (max)	Tempco/ $^\circ\text{C}$ (0 to 55°C)
10^8 (100 nA)	$0.7\% \pm 10 \text{ pA}$	0.5 pA	100 ms	$20 \mu\text{V}$	$0.01\% + 0.5 \text{ pA}$
10^6 (10 μA)	$0.5\% \pm 0.5 \text{ nA}$	50 pA	33 ms	2 mV	$0.005\% + 2 \text{ pA}$
10^4 (1 mA)	$0.5\% \pm 50 \text{ nA}$	5 nA	1 ms	200 mV	$0.005\% + 200 \text{ pA}$

* Recommended for laboratory environments, $0\text{--}35^\circ\text{C}$ up to 60% relative humidity
 † 10 Hz bandwidth
 ‡ 10%–90%; 3 dB bandwidth = $0.5/\text{settling time}$

Input Characteristics

Input impedance $>10^{10} \Omega$

Input bias current $< 5 \text{ pA}$ at 23°C , typical

Output Characteristics

Voltage output range $\pm 12 \text{ V}$ max

Output drive current $\pm 15 \text{ mA}$ max

General Specifications

Maximum common-mode voltage	300 VDC or 250 VAC _{rms}
Input terminals	Low-leakage, low-EMF, gold plated, solid copper
Overvoltage Protection to LO	
Guard Out, Guard In+, Guard In-...	120 VAC, continuous, 100 VDC, continuous, 300 VDC (5 s) 250 VAC (10 s)
Dimensions.....	3U, one slot, PXI/cPCI module; 2.0 cm × 13.0 cm × 21.6 cm (0.8 in. × 5.1 in. × 8.5 in.)
Weight.....	277 g (9.7 oz)
Measurement Category	II



Caution The NI 4022 module is rated for Measurement Category II and is intended to carry signal voltages no greater than 250 V. This module can withstand up to 2,500 V impulse voltage. Do *not* use this module for connections to signals or for measurements within Measurement Categories III or IV.

Refer to *Read Me First: Safety and Radio-Frequency Interference* for more information about Measurement Categories.

Environment

Maximum altitude	2,000 m (at 25 °C ambient temperature)
Pollution Degree	2
Indoor use only.	

Operating Environment

Ambient temperature range.....	0 °C to 55 °C (Tested in accordance with IEC-60068-2-1 and IEC-60068-2-2.)
Relative humidity range	Up to 95% at 40 °C

Storage Environment

Ambient temperature range	-40 °C to 70 °C (Tested in accordance with IEC-60068-2-1 and IEC-60068-2-2.)
Relative humidity range.....	5% to 95% noncondensing (Tested in accordance with IEC-60068-2-56.)

Shock and Vibration

Operational shock	30 g peak, half-sine, 11 ms pulse (Tested in accordance with IEC-60068-2-27. Test profile developed in accordance with MIL-PRF-28800F.)
Random vibration	
Operating	5 Hz to 500 Hz, 0.3 g _{rms}
Nonoperating	5 Hz to 500 Hz, 2.4 g _{rms} (Tested in accordance with IEC-60068-2-64. Nonoperating test profile exceeds the requirements of MIL-PRF-28800F, Class 3.)

Safety, Electromagnetic Compatibility, and CE Compliance

Safety

This product is designed to meet the requirements of the following standards of safety for electrical equipment for measurement, control, and laboratory use:

- IEC 61010-1, EN-61010-1
- UL 61010-1, CAN/CSA-C22.2 No. 61010-1



Note For UL and other safety certifications, refer to the product label or visit ni.com/certification, search by model number or product line, and click the appropriate link in the Certification column.

Electromagnetic Compatibility

This product is designed to meet the requirements of the following standards of EMC for electrical equipment for measurement, control, and laboratory use:

- EN 61326 EMC requirements; Minimum Immunity
- EN 55011 Emissions; Group 1, Class A
- CE, C-Tick, ICES, and FCC Part 15 Emissions; Class A



Note For EMC compliance, operate this device to product documentation.

CE Compliance

This product meets the essential requirements of applicable European Directives, as amended for CE marking, as follows:

- 73/23/EEC; Low-Voltage Directive (safety)
- 89/336/EEC; Electromagnetic Compatibility Directive (EMC)



Note Refer to the Declaration of Conformity (DoC) for this product for any additional regulatory compliance information. To obtain the DoC for this product, visit ni.com/certification, search by model number or product line, and click the appropriate link in the Certification column.

Waste Electrical and Electronic Equipment (WEEE)



EU Customers At the end of their life cycle, all products *must* be sent to a WEEE recycling center. For more information about WEEE recycling centers and National Instruments WEEE initiatives, visit ni.com/environment/weee.htm.

Where to Go for Support

The National Instruments Web site is your complete resource for technical support. At ni.com/support you have access to everything from troubleshooting and application development self-help resources to email and phone assistance from NI Application Engineers.

National Instruments corporate headquarters is located at 11500 North Mopac Expressway, Austin, Texas, 78759-3504. National Instruments also has offices located around the world to help address your support needs. For telephone support in the United States, create your service request at ni.com/support and follow the calling instructions or dial 512 795 8248. For telephone support outside the United States, contact your local branch office:

Australia 1800 300 800, Austria 43 0 662 45 79 90 0,
Belgium 32 0 2 757 00 20, Brazil 55 11 3262 3599,
Canada 800 433 3488, China 86 21 6555 7838,
Czech Republic 420 224 235 774, Denmark 45 45 76 26 00,
Finland 385 0 9 725 725 11, France 33 0 1 48 14 24 24,
Germany 49 0 89 741 31 30, India 91 80 41190000,
Israel 972 0 3 6393737, Italy 39 02 413091, Japan 81 3 5472 2970,
Korea 82 02 3451 3400, Lebanon 961 0 1 33 28 28,
Malaysia 1800 887710, Mexico 01 800 010 0793,
Netherlands 31 0 348 433 466, New Zealand 0800 553 322,
Norway 47 0 66 90 76 60, Poland 48 22 3390150,
Portugal 351 210 311 210, Russia 7 095 783 68 51,
Singapore 1800 226 5886, Slovenia 386 3 425 4200,
South Africa 27 0 11 805 8197, Spain 34 91 640 0085,
Sweden 46 0 8 587 895 00, Switzerland 41 56 200 51 51,
Taiwan 886 02 2377 2222, Thailand 662 278 6777,
United Kingdom 44 0 1635 523545

National Instruments, NI, ni.com, and LabVIEW are trademarks of National Instruments Corporation. Refer to the *Terms of Use* section on ni.com/legal for more information about National Instruments trademarks. Other product and company names mentioned herein are trademarks or trade names of their respective companies. For patents covering National Instruments products, refer to the appropriate location: **Help»Patents** in your software, the `patents.txt` file on your CD, or ni.com/patents.