

NI SCXI™-1194 Specifications

2.5 GHz Quad 4×1 Multiplexer

This document lists specifications for the NI SCXI-1194 multiplexer module. All specifications are subject to change without notice. Visit ni.com/manuals for the most current specifications.

Configuration Quad 4 × 1 multiplexer

Input Characteristics

All input characteristics are DC, AC_{rms}, or a combination unless otherwise specified.

Maximum switching voltage 30 V

Maximum switching current 0.5 A
(per bank)

Maximum carry current 0.5 A
(per bank)

Maximum RF power 10 W
(per bank)



Note National Instruments recommends against switching active RF signals. As a relay actuates, the channel is momentarily unterminated. Some RF sources can be damaged by reflections if their outputs are not properly terminated. Refer to your RF source documentation for more information.

DC path resistance

Initial <0.35 Ω

End-of-life >1 Ω

Path resistance is a combination of relay contact resistance and trace resistance. Contact resistance typically remains low for the life of a relay. At the end of relay life, the contact resistance rises rapidly above 1.0 Ω.

RF Performance Characteristics

Characteristic impedance (Z_0) 50 Ω nominal

Insertion loss

≤1.0 GHz <0.60 dB

≤2.0 GHz <1.10 dB

≤2.5 GHz <1.35 dB

Voltage standing wave ratio (VSWR)

≤1.0 GHz <1.25

≤2.0 GHz <1.40

≤2.5 GHz <1.45

Isolation

≤1.0 GHz >55 dB

≤2.0 GHz >45 dB

≤2.5 GHz >35 dB

Typical bank-to-bank crosstalk

≤1.0 GHz <-80 dB

≤2.5 GHz <-65 dB

Typical channel-to-channel skew <1 ps

Typical propagation delay <700 ps

Typical rise time <74 ps

Refer to Figures 1, 2, and 3 for typical insertion loss, typical VSWR, and typical isolation, respectively.

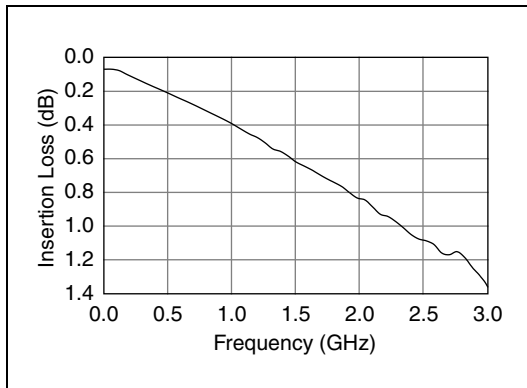

Figure 1. Typical Insertion Loss

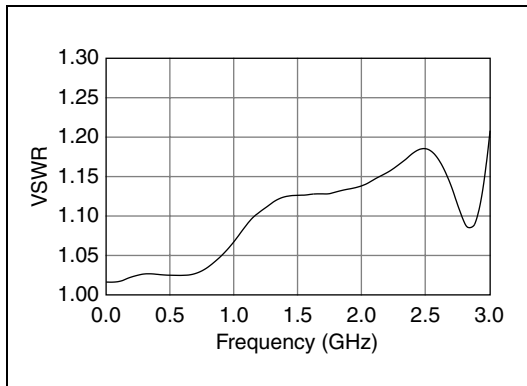

Figure 2. Typical VSWR

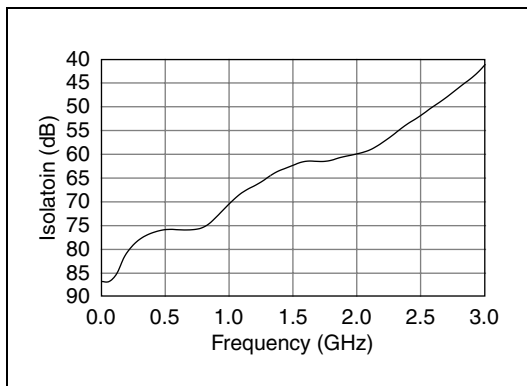

Figure 3. Typical Isolation

Dynamic Characteristics

Maximum scan rate..... 45 channels/s

Relay operate time 10.4 ms

Expected relay life

Mechanical 1,000,000 cycles

Electrical..... 300,000 cycles

(30 V, 10 mA, DC resistive)

Trigger Characteristics

Input trigger

Sources SCXI trigger lines 0–7,
rear connector

Minimum pulse width 150 ns

Output trigger

Destinations SCXI trigger lines 0–7,
rear connector

Pulse width Programmable
(1 μ s to 62 μ s)

Physical Characteristics

Relay type Electromechanical,
latching

I/O connectors 20 SMA jacks

SCXI DC power requirement

+5 VDC 50 mA

+18.5 VDC to +25 VDC 120 mA

–18.5 VDC to –25 VDC 110 mA

Dimensions (W \times H \times D)..... 3.0 cm \times 17.3 cm \times

19.6 cm

(1.2 in. \times 6.7 in. \times 7.6 in.)

Weight..... 925 g

(2 lb, 1 oz)

Environment

Operating temperature 0 $^{\circ}$ C to 50 $^{\circ}$ C

Storage temperature –20 $^{\circ}$ C to 70 $^{\circ}$ C

Relative humidity..... 5% to 85%,
noncondensing

Pollution Degree 2

Approved at altitudes up to 2,000 m.

Indoor use only.

Accessories

Visit ni.com for more information about the following accessories.

Table 1. NI Accessories for the NI SCXI-1194

| Accessory | Length | Part Number |
|--|--------|-------------|
| SMA 100, SMA male to SMA male flexible cable | 0.15 m | 763443-01 |
| | 0.45 m | 763444-01 |
| SMA 50 Ohm termination plug | — | 778353-01 |
| Torque wrench for SMA connectors | — | 187106-01 |
| SMA plug to SMB jack adapter | — | 779674-01 |

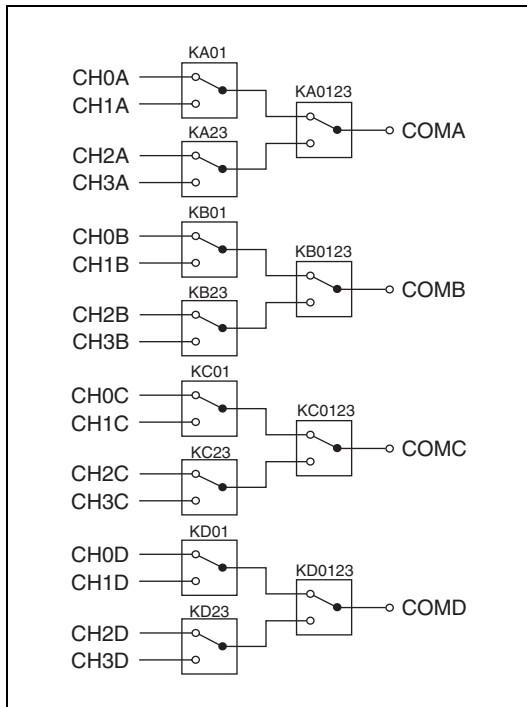

Figure 4. NI SCXI-1194 Power-On State

Compliance and Certifications

Safety

This product meets the requirements of the following standards of safety for electrical equipment for measurement, control, and laboratory use:

- IEC 61010-1, EN 61010-1
- UL 61010-1
- CAN/CSA-C22.2 No. 61010-1



Note For UL and other safety certifications, refer to the product label, or visit ni.com/certification, search by model number or product line, and click the appropriate link in the Certification column.

Electromagnetic Compatibility

| | |
|-----------------|--|
| Emissions | EN 55011 Class A at 10 m FCC Part 15A above 1 GHz |
| Immunity | EN 61326:1997 + A2:2001, Table 1 |
| EMC/EMI | CE, C-Tick, and FCC Part 15 (Class A) Compliant |



Note For EMC compliance, operate this device with shielded cabling.



Caution In the presence of 1 kV electrical fast transients on AC MAINS, switches can be set to an unknown state; in the absence of transient phenomena, switches will operate normally again.

CE Compliance

This product meets the essential requirements of applicable European Directives, as amended for CE marking, as follows:

| | |
|---|------------|
| Low-Voltage Directive (safety)..... | 73/23/EEC |
| Electromagnetic Compatibility Directive (EMC)..... | 89/336/EEC |



Note Refer to the Declaration of Conformity (DoC) for this product for any additional regulatory compliance information. To obtain the DoC for this product, visit ni.com/certification, search by model number or product line, and click the appropriate link in the Certification column.

National Instruments, NI, ni.com, and LabVIEW are trademarks of National Instruments Corporation. Refer to the *Terms of Use* section on ni.com/legal for more information about National Instruments trademarks. Other product and company names mentioned herein are trademarks or trade names of their respective companies. For patents covering National Instruments products, refer to the appropriate location: **Help»Patents** in your software, the `patents.txt` file on your CD, or ni.com/patents.