

NI PXI-2599 Specifications

26.5 GHz Dual SPDT 50 Ω Relay Module

This document lists specifications for the NI PXI-2599 relay module. All specifications are subject to change without notice. Visit ni.com/manuals for the most current specifications. The following specifications are typical at 23 °C unless otherwise specified.

Configuration 2-SPDT

Input Characteristics



Cautions This module is rated for Measurement Category I and is intended to carry signals no greater than 150 W (90 V_{rms}). This module can withstand up to 500 V impulse voltage. Do not connect to MAINS supply circuits (such as wall outlets) of 115 or 230 VAC. Do not use this module for connections to signals within Measurement Categories II, III, or IV. Refer to the *Safety and Radio-Frequency Interference Read Me First* for more information about Measurement Categories.

When hazardous voltages (>42.4 V_{pk}/60 VDC) are present on any relay terminal, all terminals must be considered hazardous. Ensure that external wiring or any circuits connected to the device are properly insulated from human contact.



Caution Active RF signals must not be switched. As a relay actuates, the channel is momentarily unterminated. Some RF sources can be damaged by reflections if their outputs are not properly terminated. Refer to your RF source documentation for more information.

Maximum RF carry power 150 W
(50 Ω load)

Maximum voltage 90 V_{rms}
(cold switching only)

Maximum carry current 1.73 A_{rms}
(per channel)

RF Performance Characteristics

Characteristic impedance (Z_0) 50 Ω nominal

Insertion loss

≤ 3 GHz <0.2 dB
 ≤ 8 GHz <0.3 dB
 ≤ 12.4 GHz <0.4 dB
 ≤ 18 GHz <0.5 dB
 ≤ 26.5 GHz <0.7 dB

Voltage standing wave ratio (VSWR)

≤ 3 GHz <1.20
 ≤ 8 GHz <1.30
 ≤ 12.4 GHz <1.40
 ≤ 18 GHz <1.50
 ≤ 26.5 GHz <1.70

Open channel isolation

≤ 3 GHz <80 dB
 ≤ 8 GHz <70 dB
 ≤ 12.4 GHz <60 dB
 ≤ 18 GHz <60 dB
 ≤ 26.5 GHz <55 dB

RF carry power

≤ 3 GHz 150 W
 ≤ 8 GHz 95 W
 ≤ 12.4 GHz 75 W
 ≤ 18 GHz 65 W
 ≤ 26.5 GHz 25 W

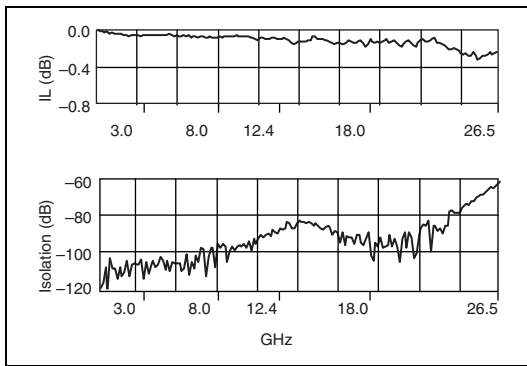

Figure 1. Typical Insertion Loss and Isolation

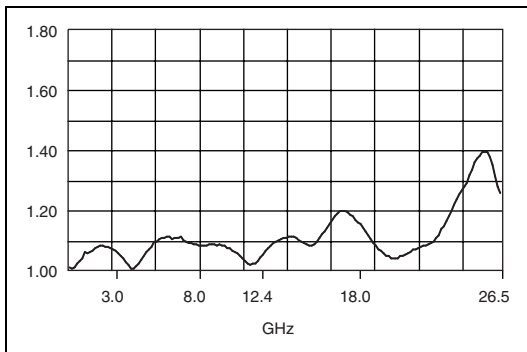

Figure 2. Typical VSWR

Dynamic Characteristics

- Recommended cycle speed5 channels/s
- Relay operate/release time.....10 ms
- Expected relay life
 - Mechanical 1×10^7 cycles

Trigger Characteristics

Input trigger

- SourcesPXI trigger lines 0–7
- Minimum pulse width150 ns



Note The NI PXI-2599 can recognize trigger pulse widths less than 150 ns by disabling digital filtering. For information about disabling digital filtering, refer to the *NI Switches Help*.

Output trigger

- DestinationsPXI trigger lines 0–7
- Pulse widthProgrammable
(1 μ s to 62 μ s)

Physical Characteristics

- Relay manufacturer/PN Radial/R570 series
- Relay type Electromechanical, latching
- Contact material Beryllium copper, gold-plated
- I/O connector 6 SMA jacks
- SMA Torque 0.8 N · m to 1.1 N · m
(7 in · lbs to 10 in · lbs)
- PXI power requirement 2.5 W at 3.3 V,
1 W at 5 V,
3 W at 12 V
- Dimensions (W × H × D) 3U, one slot, PXI/cPCI module; 2.0 cm × 13.0 cm × 21.6 cm;
(0.8 in. × 5.1 in. × 8.5 in.)
- Weight 260 g (9.2 oz)

Environment

- Operating temperature 0 °C to 55 °C
- Storage temperature –20 °C to 70 °C
- Relative humidity 5% to 85%, noncondensing
- Pollution Degree 2

Approved at altitudes up to 2,000 m.

Indoor use only.

Shock and Vibration

- Operational shock 30 g peak, half-sine, 11 ms pulse (Tested in accordance with IEC-60068-2-27. Test profile developed in accordance with MIL-PRF-28800F.)

Random vibration

- Operating 5 to 500 Hz, 0.3 g_{rms}
- Nonoperating 5 to 500 Hz, 2.4 g_{rms}
(Tested in accordance with IEC-60068-2-64. Nonoperating test profile exceeds the requirements of MIL-PRF-28800F, Class 3.)

Accessories

Visit ni.com for more information about the following accessories.

Table 1. NI Accessories for the NI PXI-2599

Accessory	Part Number
SMA 100, SMA male to SMA male flexible cable, 0.15 m	763443-01
SMA 100, SMA male to SMA male flexible cable, 0.45 m	763444-01
Torque Wrench for SMA Connectors (1 N · m)	187106-01

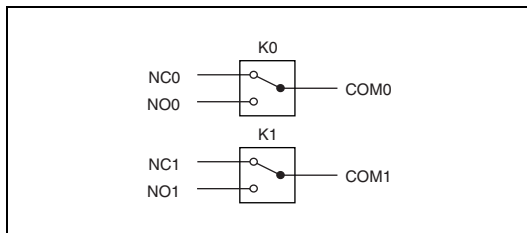

Figure 3. NI PXI-2599 Power-On State

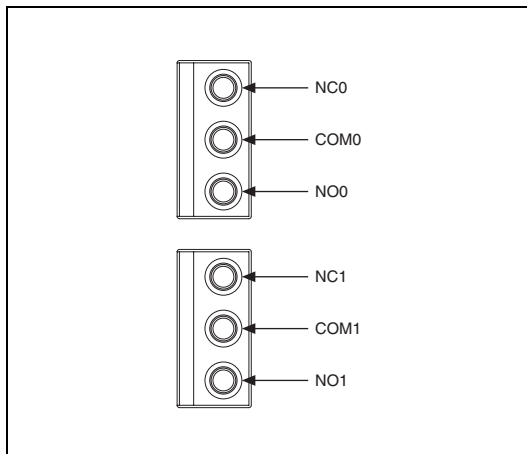

Figure 4. NI PXI-2599 Front Panel Connectors

Compliance and Certifications

Safety

This product meets the requirements of the following standards of safety for electrical equipment for measurement, control, and laboratory use:

- IEC 61010-1, EN 61010-1
- UL 61010-1
- CAN/CSA-C22.2 No. 61010-1



Note For UL and other safety certifications, refer to the product label, or visit ni.com/certification, search by model number or product line, and click the appropriate link in the Certification column.

Electromagnetic Compatibility

Emissions	EN 55011 Class A at 10 m FCC Part 15A above 1 GHz
Immunity	EN 61326:1997 + A2:2001, Table 1
EMC/EMI	CE, C-Tick, and FCC Part 15 (Class A) Compliant



Note For EMC compliance, operate this device with shielded cabling.

CE Compliance

This product meets the essential requirements of applicable European Directives, as amended for CE marking, as follows:

Low-Voltage Directive (safety).....73/23/EEC

Electromagnetic Compatibility

Directive (EMC).....89/336/EEC



Note Refer to the Declaration of Conformity (DoC) for this product for any additional regulatory compliance information. To obtain the DoC for this product, visit ni.com/certification, search by model number or product line, and click the appropriate link in the Certification column.

National Instruments, NI, ni.com, and LabVIEW are trademarks of National Instruments Corporation. Refer to the *Terms of Use* section on ni.com/legal for more information about National Instruments trademarks. Other product and company names mentioned herein are trademarks or trade names of their respective companies. For patents covering National Instruments products, refer to the appropriate location: **Help»Patents** in your software, the `patents.txt` file on your CD, or ni.com/patents.