

Getting Started with the NI PCI-8254R

The NI PCI-8254R (NI 8254R) is an IEEE 1394a interface device for PCI with reconfigurable I/O (RIO). This document describes how to install and configure the necessary hardware and software components to begin using the NI 8254R.

What You Need to Get Started

You need the following items to set up and use the NI 8254R:

- NI 8254R IEEE 1394a interface device
- IEEE 1394 camera
- IEEE 1394a cable
- Cable for digital I/O
- External power supply to support powering isolated outputs
- Computer running Microsoft Windows Vista/2000/XP with at least one available PCI slot



Visit ni.com/info and enter `rvisionvista` for more information about National Instruments image acquisition device compatibility with Windows Vista.

- NI Vision Acquisition Software 8.2.1 or later, which includes the NI-IMAQdx and NI-IMAQ I/O driver software.
- Optional software for developing applications:
 - NI Vision Builder for Automated Inspection
 - NI Vision Development Module
 - LabVIEW
 - LabVIEW FPGA Module
 - LabWindows™/CVI™
 - Microsoft Visual Basic

Optional Equipment

National Instruments offers a variety of products for use with the NI 8254R, including the following:

- Digital I/O cable and horizontal DIN rail terminal block (part number 778790-01)¹
- Digital I/O cable and vertical DIN rail terminal block (part number 778791-01)¹
- 24 V, 50 W power supply (part number 778794-01)
- NI Vision I/O Terminal Block and Prototyping Accessory (part number 779166-01)
- IEEE 1394 cameras

¹ When using this accessory with the NI 8254R, three of the digital I/O signals on the device are not accessible. Refer to Chapter 3, *Signal Connections*, of the *NI PCI-8254R User Manual* for more information.

- LED ringlight and constant current source (part number 778787-01)
- 12 mm fixed focal length lens (part number 778789-01)

Refer to the National Instruments catalog, visit ni.com, or call the National Instruments office nearest you for more specific information about these products

Related Documentation

The following documents contain additional information that you may find helpful:

- *NI PCI-8254R User Manual*—Contains information about programming options, hardware functionality, and signal connections.
- *NI Vision Acquisition Software Release Notes*—Contains information about new functionality, minimum system requirements, and installation instructions for the NI-IMAQdx driver software.
- *Measurement & Automation Explorer Help for NI-IMAQdx*—Describes how to configure NI-IMAQdx driver software, NI image acquisition devices, and cameras using Measurement & Automation Explorer (MAX).
- *NI-IMAQdx User Manual*—Contains fundamental programming concepts for the NI-IMAQdx driver software and terminology for using NI image acquisition devices.
- *LabVIEW Help*—This document contains reference information for the NI-IMAQ I/O shutdown states VIs, terminal references for the configurable I/O module on the NI-IMAQ I/O device, and parameter references for the parameters you can set for the NI-IMAQ I/O device in the Read/Write control. To locate the information, search for NI-IMAQ I/O in the *LabVIEW Help*.

Safety Information



Caution The following paragraphs contain important safety information you *must* follow when installing and operating the device.

Do *not* operate the device in a manner not specified in the documentation. Misuse of the device may result in a hazard and may compromise the safety protection built into the device. If the device is damaged, turn it off and do *not* use it until service-trained personnel can check its safety. If necessary, return the device to National Instruments for repair.

Keep away from live circuits. Do *not* remove equipment covers or shields unless you are trained to do so. If signal wires are connected to the device, hazardous voltages can exist even when the equipment is turned off. To avoid a shock hazard, do *not* perform procedures involving cover or shield removal unless you are qualified to do so. Disconnect all field power prior to removing covers or shields.

If the device is rated for use with hazardous voltages ($>30 V_{\text{rms}}$, $42.4 V_{\text{pk}}$, or $60 V_{\text{dc}}$), it may require a safety earth-ground connection wire. Refer to the device specifications for maximum voltage ratings.

Because of the danger of introducing additional hazards, do *not* install unauthorized parts or modify the device. Use the device only with the chassis, modules, accessories, and cables specified in the installation instructions. All covers and filler panels *must* be installed while operating the device.

Do *not* operate the device in an explosive atmosphere or where flammable gases or fumes may be present. Operate the device only at or below the pollution degree stated in the specifications. Pollution

consists of any foreign matter—solid, liquid, or gas—that may reduce dielectric strength or surface resistivity. The following is a description of pollution degrees.

- Pollution Degree 1—No pollution or only dry, nonconductive pollution occurs. The pollution has no effect.
- Pollution Degree 2—Normally only nonconductive pollution occurs. Occasionally, nonconductive pollution becomes conductive because of condensation.
- Pollution Degree 3—Conductive pollution or dry, nonconductive pollution occurs. Nonconductive pollution becomes conductive because of condensation.

Clean the device and accessories by brushing off light dust with a soft, nonmetallic brush. Remove other contaminants with a stiff, nonmetallic brush. The unit *must* be completely dry and free from contaminants before returning it to service.

You *must* insulate signal connections for the maximum voltage for which the device is rated. Do *not* exceed the maximum ratings for the device. Remove power from signal lines before connection to or disconnection from the device.



Caution National Instruments measurement products may be classified as either Measurement Category I or II. Operate products at or below the Measurement Category level specified in the hardware specifications.

Measurement Category¹: Measurement circuits are subjected to working voltages² and transient stresses (overvoltage) from the circuit to which they are connected during measurement or test. Measurement Category establishes standardized impulse withstand voltage levels that commonly occur in electrical distribution systems. The following is a description of Measurement (Installation³) Categories:

- Measurement Category I is for measurements performed on circuits *not* directly connected to the electrical distribution system referred to as MAINS⁴ voltage. This category is for measurements of voltages from specially protected secondary circuits. Such voltage measurements include signal levels, special equipment, limited-energy parts of equipment, circuits powered by regulated low-voltage sources, and electronics.
- Measurement Category II is for measurements performed on circuits directly connected to the electrical distribution system. This category refers to local-level electrical distribution, such as that provided by a standard wall outlet (e.g., 115 V for U.S. or 230 V for Europe). Examples of Measurement Category II are measurements performed on household appliances, portable tools, and similar products.
- Measurement Category III is for measurements performed in the building installation at the distribution level. This category refers to measurements on hard-wired equipment such as equipment in fixed installations, distribution boards, and circuit breakers. Other examples are

¹ Measurement Categories as defined in electrical safety standard IEC 61010-1.

² Working voltage is the highest rms value of an AC or DC voltage that can occur across any particular insulation.

³ Measurement Category is also referred to as Installation Category.

⁴ MAINS is defined as the (hazardous live) electrical supply system to which equipment is designed to be connected for the purpose of powering the equipment. Suitably rated measuring circuits may be connected to the MAINS for measuring purposes.

wiring, including cables, bus-bars, junction boxes, switches, socket-outlets in the fixed installation, and stationary motors with permanent connections to fixed installations.

- Measurement Category IV is for measurements performed at the primary electrical supply installation (<1,000 V). Examples include electricity meters and measurements on primary overcurrent protection devices and on ripple control units.

Unpacking

The NI 8254R ships in an antistatic package to prevent electrostatic discharge from damaging device components. To avoid such damage in handling the device, take the following precautions:

1. Ground yourself using a grounding strap or by holding a grounded object, such as the computer chassis.
2. Touch the antistatic package to a metal part of the computer chassis before removing the device from the package.



Caution *Never* touch the exposed pins of connectors.

3. Remove the device from the package and inspect it for loose components or any other signs of damage. Notify National Instruments if the device appears damaged in any way. Do *not* install a damaged device in the computer.

Store the NI 8254R in the antistatic package when not in use.

Installation

The following instructions are for general installation. Refer to the documentation provided by your computer manufacturer for specific instructions and warnings. Refer to the [Specifications](#) section for typical power requirements for the NI 8254R.

1. Install NI Vision Acquisition Software before installing the NI 8254R. Refer to the *NI Vision Acquisition Software Release Notes* for specific installation instructions.
2. Power off and unplug the computer.



Caution To protect yourself and the computer from electrical hazards, the computer *must* remain unplugged until the installation is complete.

3. Remove the computer cover to expose the expansion slots.
4. Touch a metal part on the computer case to discharge any static electricity on your clothes or body. Static electricity can damage the device.
5. Choose an unused PCI slot, and remove the corresponding expansion slot cover on the back panel of the computer.
6. Remove your device from the antistatic package and gently rock the device into the slot. The connection may be tight, but do *not* force the device into place.



Note Check that the bracket of your device lines up with the hole in the back panel rail of the computer chassis.

7. Secure the device mounting bracket to the back panel rail of the computer.

8. To provide power to your camera, connect an unused power connector from the ATX power supply on your computer to the Camera Power ATX connector on your NI 8254R, shown in Figure 1.

Figure 1 shows the information about placement of the connectors on the NI 8254R.

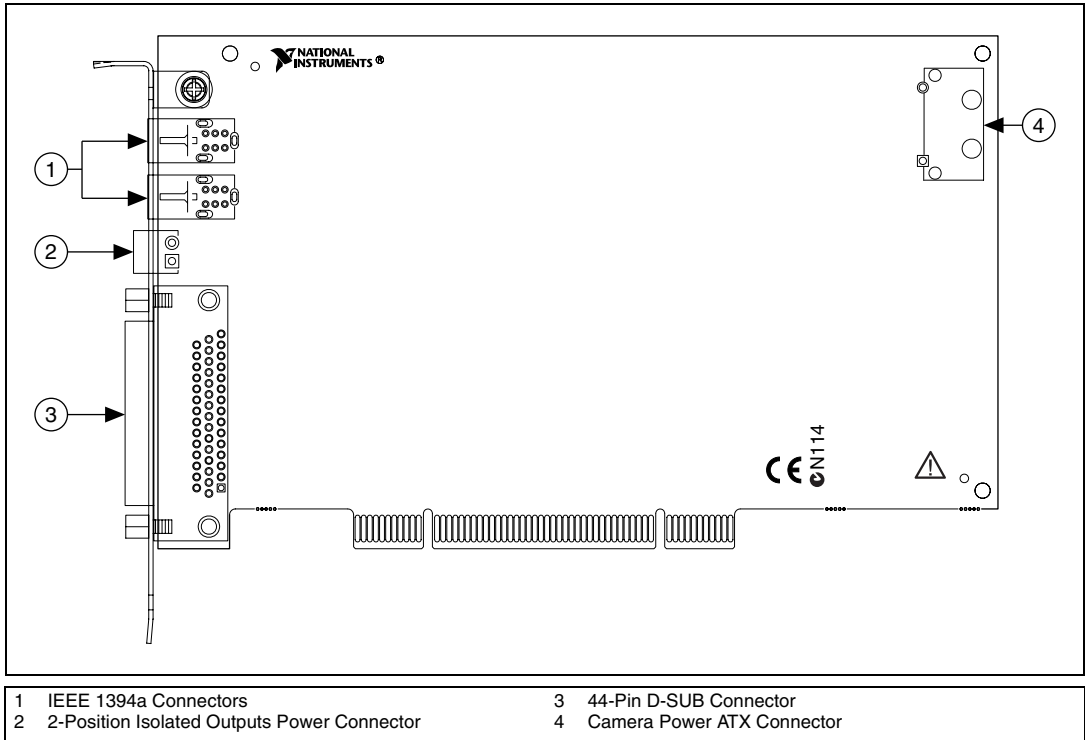

Figure 1. NI 8254R Connectors

9. Replace the computer cover.
10. Connect the IEEE 1394a cable to your camera. Refer to your camera manufacturer documentation for specific instructions about how to connect the IEEE 1394a cable to your camera.
11. Connect the IEEE 1394a cable to an IEEE 1394a connector on the NI 8254R front panel. Refer to Figure 1 for the location of the IEEE 1394a connectors on the NI 8254R.
12. Plug in and power on the computer.

The NI 8254R is now installed and the camera is connected.

Wiring Isolated Output Power to the NI 8254R

This section describes how to connect the NI desktop power supply for the isolated outputs (part number 778794-01) to the NI 8254R. For instructions on how to connect a separate main supply, refer to the [Connecting to the Isolated Outputs Power Supply](#) section.



Caution Do *not* connect the NI 8254R isolated power to a source less than 5 VDC or greater than 30 VDC. Doing so could damage the NI 8254R.

To connect power for the isolated outputs to the NI 8254R, refer to Figures 2 through 6 while completing the following steps:

1. If you are using the NI desktop power supply, remove the 4-position power connector connected to the power supply, shown in Figure 2.
 - a. Reconnect the wire that was connected to the V position on the 4-position power connector to the V position on the 2-position isolated outputs power connector, shown in Figure 3.
 - b. Reconnect the wire that was connected to the C position on the 4-position power connector to the C position on the 2-position isolated outputs power connector, shown in Figure 3.

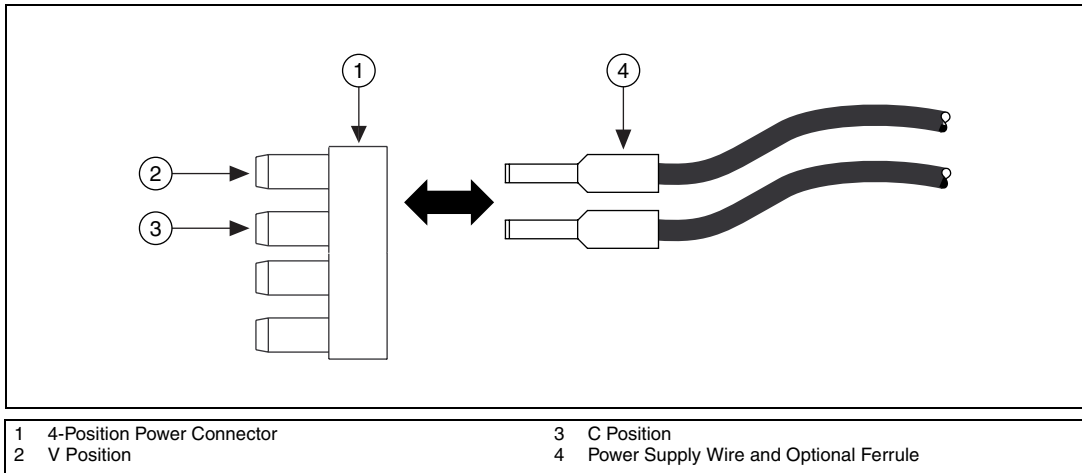

Figure 2. Removing the 4-Position Power Connector from the Power Supply

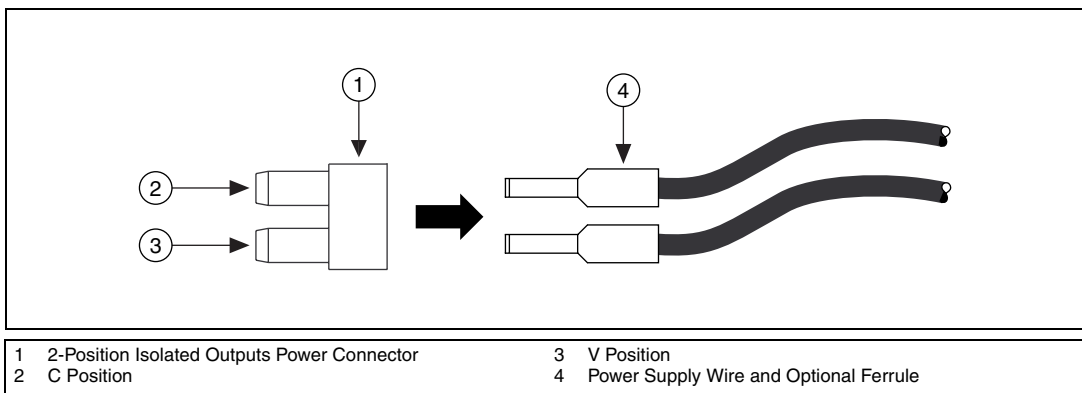

Figure 3. Connecting the 2-Position Power Connector to the Power Supply

2. Plug the 2-position isolated outputs power connector from the power supply into the power receptacle on the NI 8254R.

- (Optional) To suppress electromagnetic interference, install a ferrite on the power supply cable as close to the connection to the NI 8254R as possible. Wrap the power supply cable around the ferrite two times, as shown in Figures 4 and 5.

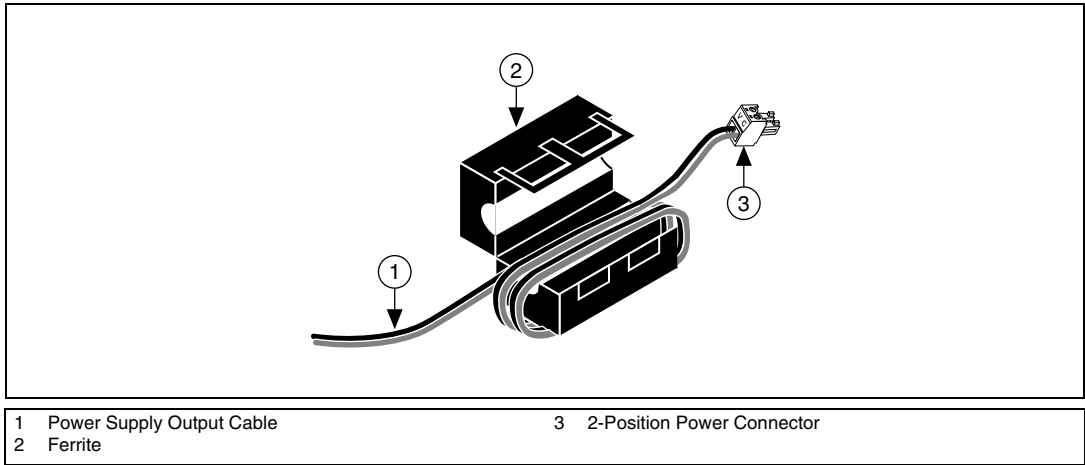

Figure 4. Installing a Ferrite Connector on the Power Supply Cable

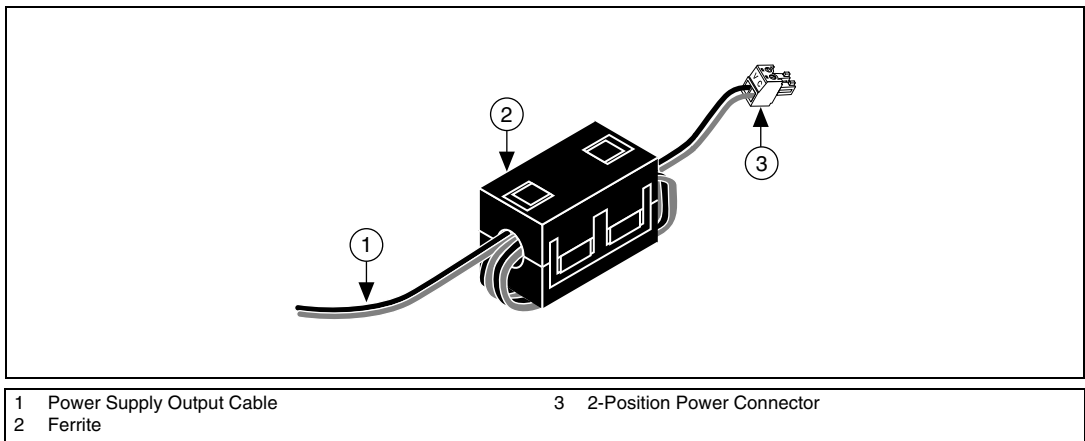

Figure 5. Closed Ferrite on the Power Supply Cable

- Plug the power supply cable into the power supply.
- Plug the power supply cord into an outlet.

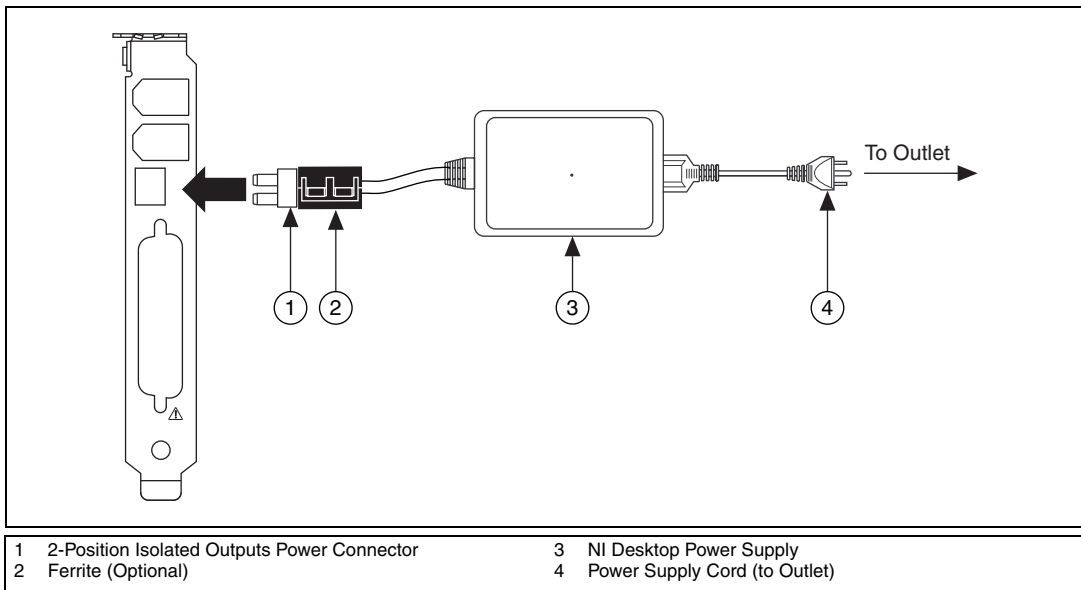

Figure 6. Wiring Power to the NI 8254R

Connecting to the Isolated Outputs Power Supply

If you use a power supply other than the NI desktop power supply, follow the instructions in this section to connect power to the NI 8254R.



Note If you are not using the NI desktop power supply, you can optionally use 0.75 mm², 18 AWG ferrules according to the manufacturer specifications to terminate the wires leading to the 2-position power connector, shown in Figure 7. Ferrules are available from Phoenix Contact (part number 3200519).

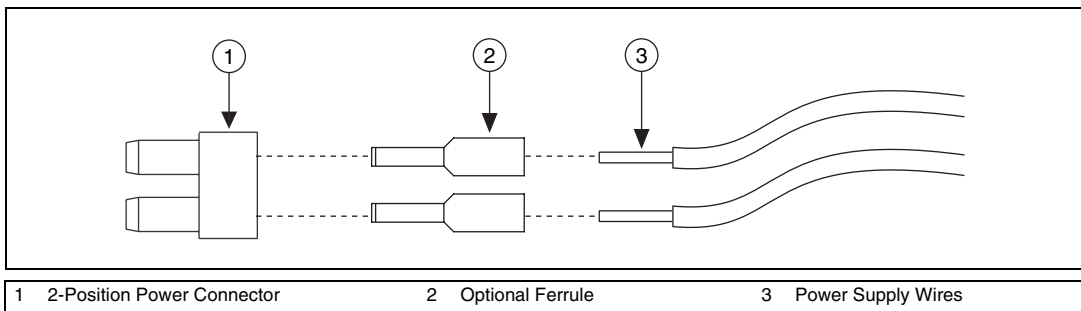

Figure 7. Wiring a Third-Party Power Supply to the 2-Position Power Connector



Caution Do *not* connect the NI 8254R isolated power to a source less than 5 VDC or greater than 30 VDC. Doing so could damage the NI 8254R.

The NI 8254R ships with a 2-position power connector that plugs directly into the isolated outputs power input connector on the NI 8254R. To wire power to the 2-position connector, complete the following steps:

1. Wire the voltage output of the isolated power supply to the isolated outputs power input, labeled **V**, on the 2-position connector.
2. Wire the common-mode signal (ground) output of the power supply to the isolated outputs common-mode signal input, labeled **C**, on the 2-position connector.

Configuring the NI 8254R

After you have installed the NI 8254R and powered on your computer, Windows will recognize the device and assign resources to it. Use Measurement & Automation Explorer (MAX), the National Instruments configuration utility, to configure the IEEE 1394 camera connected to the NI 8254R for acquisition. Refer to the *Measurement & Automation Explorer Help for NI-IMAQdx* for additional information about configuring the NI 8254R.



Note Before configuring the device in MAX, ensure that you installed the NI-IMAQdx driver software.

Specifications

The following specifications apply to the NI IEEE 1394a interface device. These specifications are typical at 25 °C, unless otherwise stated.

TTL Inputs and Outputs

Digital logic levels

Level	Minimum	Maximum
Input low voltage (V_{IL})	0 V	0.5 V
Input high voltage (V_{IH})	2.2 V	5 V
Output low voltage (V_{OL}), at 5 mA	—	0.4 V
Output high voltage (V_{OH}), at 5 mA	2.4 V	—

TTL Inputs

Number of channels 2

Maximum pulse rate 2 MHz

Minimum pulse detected..... 500 ns

Power-on state..... Input (high-impedance) 61.9 k Ω pull-up to 5V

TTL Outputs

Number of channels 10

Output voltage range..... 0 V to 5 V

Maximum pulse rate 2 MHz

Optically Isolated Inputs and Outputs

Isolated (Current Sinking) Inputs

Number of channels	13
Input voltage range	0 V to 30 V
Input ON voltage.....	3.5 V to 30 V
Input OFF voltage.....	0 V to 2 V
Turn-on current	7.1 mA, typical 14 mA, maximum
Maximum pulse rate	100 kHz
Minimum pulse detected.....	10 μ s
Reverse polarity protection	Yes, -30 V

Isolated (Current Sourcing) Outputs

Number of channels	4
On-state voltage range	5 V to 30 V, maximum
Maximum on-state voltage drop from V	1.2 V at 100 mA
Output current	
5 V isopower.....	50 mA, maximum
24 V isopower	100 mA, maximum
30 V isopower	100 mA, maximum
Maximum pulse rate	10 kHz (maximum load resistance 100 k Ω)
Minimum pulse generated	100 μ s
Reverse polarity protection	Yes

IEEE 1394

Number of ports	2
Speed.....	100, 200, or 400 Mbps

Power Requirements

IEEE 1394 bus power ¹	18 W, maximum (shared by both ports)
Isolated supply ²	5 to 30 VDC
Camera interface	IEEE 1394a

Physical Characteristics

Dimensions	10.7 cm \times 17.5 cm (4.2 in. \times 6.9 in.)
Weight	114 g (4.0 oz)

¹ The bus power specification assumes that power is provided to the NI 8254R from the host computer power supply via the ATX power connector. If power is not supplied through this connector, camera power is supplied by the PCI bus and should be limited to 5 W, shared by both ports.

² Do *not* draw more than 500 mA combined from the V_{iso} pins on the 44-pin D-SUB connector. Do *not* draw more than 100 mA from 30 V isolated outputs. Do *not* draw more than 50 mA from 5 V isolated outputs.

Environment

The NI 8254R is intended for indoor use only.

Operating temperature0 °C to 55 °C

Storage temperature–20 °C to 70 °C

Relative humidity5% to 90%, noncondensing

Pollution Degree2

Measurement CategoryI

Approved at altitudes up to 2,000 m.

Safety

This product is designed to meet the requirements of the following standards of safety for electrical equipment for measurement, control, and laboratory use:

- IEC 61010-1, EN 61010-1
- UL 61010-1, CSA 61010-1



Note For UL and other safety considerations, refer to the product label, or visit ni.com/certification, search by model number or product line, and click the appropriate link in the Certification column.

Electromagnetic Compatibility

This product is designed to meet the requirements of the following standards of EMC for electrical equipment for measurement, control, and laboratory use:

- EN 61326 EMC requirements; Minimum Immunity
- EN 55011 Emissions; Group 1, Class A
- CE, C-Tick, ICES, and FCC Part 15 Emissions; Class A



Note For EMC compliance, operate this device according to product documentation.

CE Compliance

This product meets the essential requirements of applicable European Directives, as amended for CE marking, as follows:

- 73/23/EEC; Low-Voltage Directive (safety)
- 89/336/EEC; Electromagnetic Compatibility Directive (EMC)



Note Refer to the Declaration of Conformity (DoC) for this product for any additional regulatory compliance information. To obtain the DoC for this product, visit ni.com/certification, search by model number or product line, and click the appropriate link in the Certification column.

Waste Electrical and Electronic Equipment (WEEE)



EU Customers At the end of their life cycle, all products *must* be sent to a WEEE recycling center. For more information about WEEE recycling centers and National Instruments WEEE initiatives, visit ni.com/environment/weee.htm.

Where to Go for Support

The National Instruments Web site is your complete resource for technical support. At ni.com/support you have access to everything from troubleshooting and application development self-help resources to email and phone assistance from NI Application Engineers.

A Declaration of Conformity (DoC) is our claim of compliance with the Council of the European Communities using the manufacturer's declaration of conformity. This system affords the user protection for electronic compatibility (EMC) and product safety. You can obtain the DoC for your product by visiting ni.com/certification. If your product supports calibration, you can obtain the calibration certificate for your product at ni.com/calibration.

National Instruments corporate headquarters is located at 11500 North Mopac Expressway, Austin, Texas, 78759-3504. National Instruments also has offices located around the world to help address your support needs. For telephone support in the United States, create your service request at ni.com/support and follow the calling instructions or dial 512 795 8248. For telephone support outside the United States, contact your local branch office:

Australia 1800 300 800, Austria 43 0 662 45 79 90 0, Belgium 32 0 2 757 00 20,
Brazil 55 11 3262 3599, Canada 800 433 3488, China 86 21 6555 7838,
Czech Republic 420 224 235 774, Denmark 45 45 76 26 00, Finland 385 0 9 725 725 11,
France 33 0 1 48 14 24 24, Germany 49 0 89 741 31 30, India 91 80 41190000,
Israel 972 0 3 6393737, Italy 39 02 413091, Japan 81 3 5472 2970, Korea 82 02 3451 3400,
Lebanon 961 0 1 33 28 28, Malaysia 1800 887710, Mexico 01 800 010 0793,
Netherlands 31 0 348 433 466, New Zealand 0800 553 322, Norway 47 0 66 90 76 60,
Poland 48 22 3390150, Portugal 351 210 311 210, Russia 7 495 783 68 51, Singapore 1800 226 5886,
Slovenia 386 3 425 42 00, South Africa 27 0 11 805 8197, Spain 34 91 640 0085,
Sweden 46 0 8 587 895 00, Switzerland 41 56 200 51 51, Taiwan 886 02 2377 2222,
Thailand 662 278 6777, Turkey 90 212 279 3031, United Kingdom 44 0 1635 523545

National Instruments, NI, ni.com, and LabVIEW are trademarks of National Instruments Corporation. Refer to the *Terms of Use* section on ni.com/legal for more information about National Instruments trademarks. Other product and company names mentioned herein are trademarks or trade names of their respective companies. For patents covering National Instruments products, refer to the appropriate location: **Help»Patents** in your software, the `patents.txt` file on your CD, or ni.com/patents.