

OPERATING INSTRUCTIONS

CompactRIO™ cRIO-9052

CompactRIO StarFabric Interface

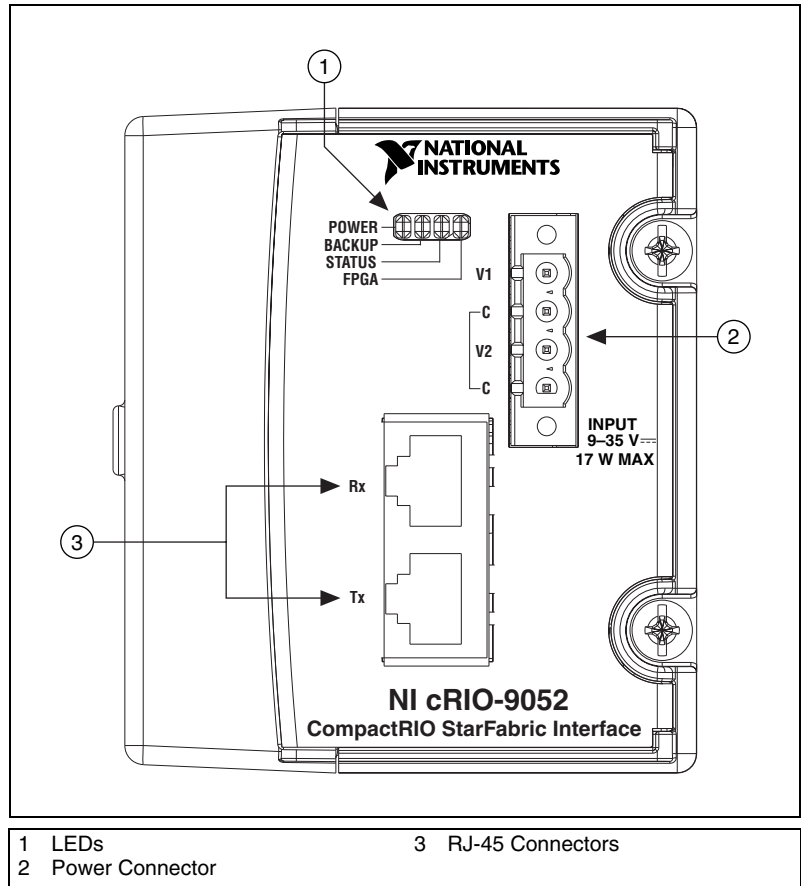

Figure 1. CompactRIO cRIO-9052

These operating instructions describe how to connect the National Instruments cRIO-9052 to a laptop, PC, or PXI chassis and how to use the features of the cRIO-9052. For information about installing, configuring, and programming the CompactRIO reconfigurable chassis that the cRIO-9052 works with, refer to the *CompactRIO Bookshelf* at **Start»All Programs»National Instruments»CompactRIO»Search the CompactRIO Bookshelf**.

Safety Guidelines

Operate the cRIO-9052 only as described in these operating instructions.

Safety Guidelines for Hazardous Locations

The cRIO-9052 is suitable for use in Class I, Division 2, Groups A, B, C, D, T4 hazardous locations; Class I, Zone 2, AEx nC IIC T4, and Ex nC IIC T4 hazardous locations; and nonhazardous locations only. Follow these guidelines if you are installing the cRIO-9052 in a potentially explosive environment. Not following these guidelines may result in serious injury or death.



Caution Do *not* disconnect the power supply wires and connectors from the controller unless power has been switched off.



Caution Do *not* install or remove the controller unless power has been switched off.



Caution Substitution of components may impair suitability for Class I, Division 2.



Caution For Zone 2 applications, install the CompactRIO system in an enclosure rated to at least IP 54 as defined by IEC 60529 and EN 60529.

Special Conditions for Safe Use in Europe

This equipment has been evaluated as EEx nC IIC T4 equipment under DEMKO Certificate No. 03 ATEX 0324020X. Each controller is marked  II 3G and is suitable for use in Zone 2 hazardous locations.

About the cRIO-9052

The cRIO-9052 works with a host system through the NI 8310, which is a StarFabric interface device, allowing you to connect to and control any CompactRIO reconfigurable chassis from a Windows host or a host that is running the LabVIEW Real-Time Module. Using a Windows host or a host that is running the LabVIEW Real-Time Module to connect to and control a CompactRIO reconfigurable chassis allows you to transfer to and receive from the reconfigurable chassis very quickly. The host system is the PC, PXI chassis, or laptop computer you have installed the NI 8310 into. For information about StarFabric, visit www.stargen.com/about.

When you have started an application that is handled by the CompactRIO reconfigurable chassis that has the cRIO-9052 installed, you can physically disconnect the host from the CompactRIO reconfigurable chassis while the application continues to run.

You can reconnect the host system to the reconfigurable chassis while an application is running on the reconfigurable chassis. If the host system contains an NI PCI-8310 or an NI PXI-8310, you must reboot the host before you can view the running program on the reconfigurable chassis. If you are using an NI CardBus-8310, you can view the running program on the reconfigurable chassis as soon as you reconnect the host system to it and the operating system has detected the reconfigurable chassis.

Complete the following steps to set up and use the cRIO-9052:

1. Install the cRIO-9052 on a cRIO-91xx chassis. Refer to the [Installing the cRIO-9052 on the Chassis](#) section for more information.
2. Wire the cRIO-9052 for power. Refer to the [Wiring Power to the cRIO-9052](#) section for more information.
3. Wire the cRIO-9052 for connectivity to the host. Refer to the [Wiring the cRIO-9052 for Connectivity to the Host](#) section for more information.
4. Install the driver software on the host system, if applicable. Refer to the [Driver Software](#) section for more information.
5. Install the NI 8310 on the host system. Refer to the [Install the NI 8310](#) section for more information.
6. Configure the reconfigurable chassis. Refer to the [Configure the CompactRIO Reconfigurable Chassis](#) section for more information.

Required Components

You must have the following components installed and configured to use the cRIO-9052:

- cRIO-9052
- Laptop (CardBus), PC (PCI), or PXI chassis you will use to interact with a Compact RIO reconfigurable chassis
- A CompactRIO reconfigurable chassis (cRIO-91xx)
- NI 8310
- Power supply (9 V to 35 V)
- Two shielded CAT5 Ethernet cables
- Six ferrites (two for each CAT5 cable and two for each power supply input)

Cabling

The transmit and receive cables must be within 2.54 cm (1 in.) of the same length. The maximum cable length is 14 m (45.93 ft.).

To ensure that the device or system passes the emission standards in your area, you must install a ferrite at each end of both CAT5 Ethernet cables and on each of the power supply inputs, and thus you need six ferrites.

NI provides accessory kits that include the appropriate length CAT5 Ethernet cables and required ferrites. Visit ni.com and search for one of the part numbers listed in Table 1 for more information about these kits and to purchase them.

Table 1. National Instruments Cable Sets

Cable Length (m)	Description	Orderable Part Number ¹	Cable Part Number ²
3 m	3 m StarFabric Cable Set CBL3S-NI	779544-03	763640-03
10 m	10 m StarFabric Cable Set CBL10S-NI	779544-10	763640-10
14 m	14 m StarFabric Cable Set CBL14S-NI	779544-14	763640-14

¹ This is the part number you use to order the cable kit from NI.
² This is the part number that appears on the cable.

Installing the cRIO-9052 on the Chassis

Figure 2 shows the dimensions of the cRIO-9052.

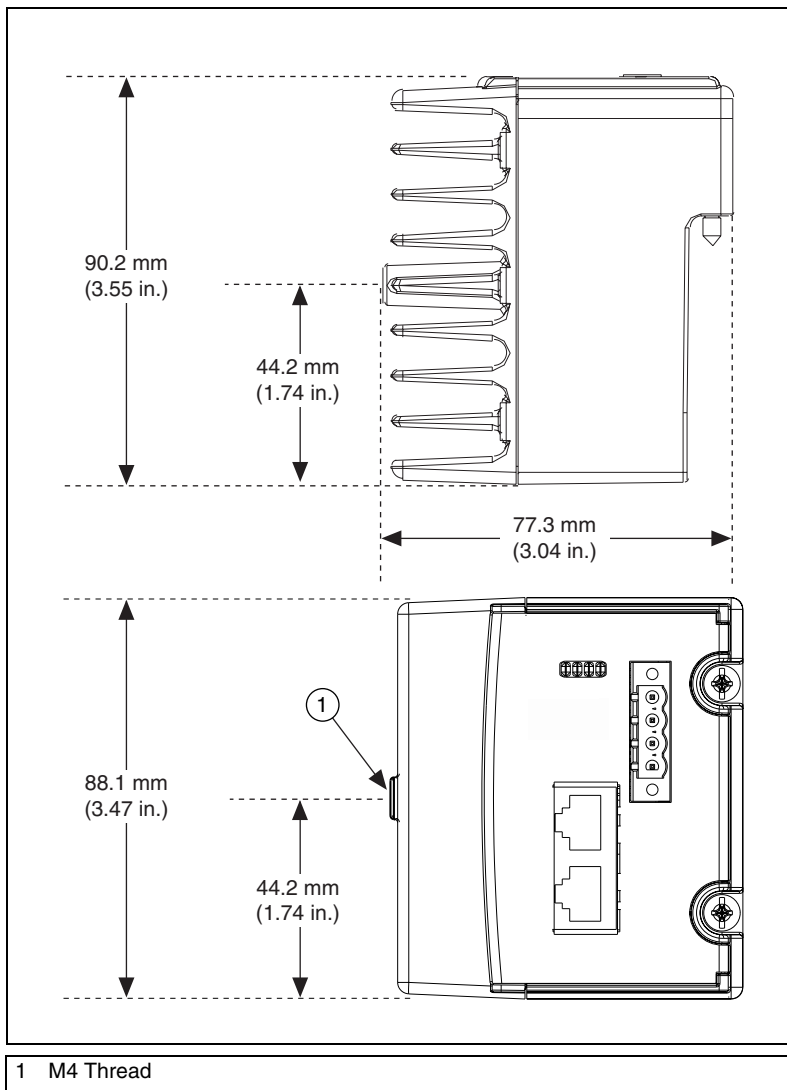

Figure 2. cRIO-9052 Front and Bottom Views with Dimensions

Complete the following steps to install the cRIO-9052 on the chassis:

1. Make sure that no power is connected to the cRIO-9052 or the chassis.
2. Align the controller with the chassis as shown in Figure 3.

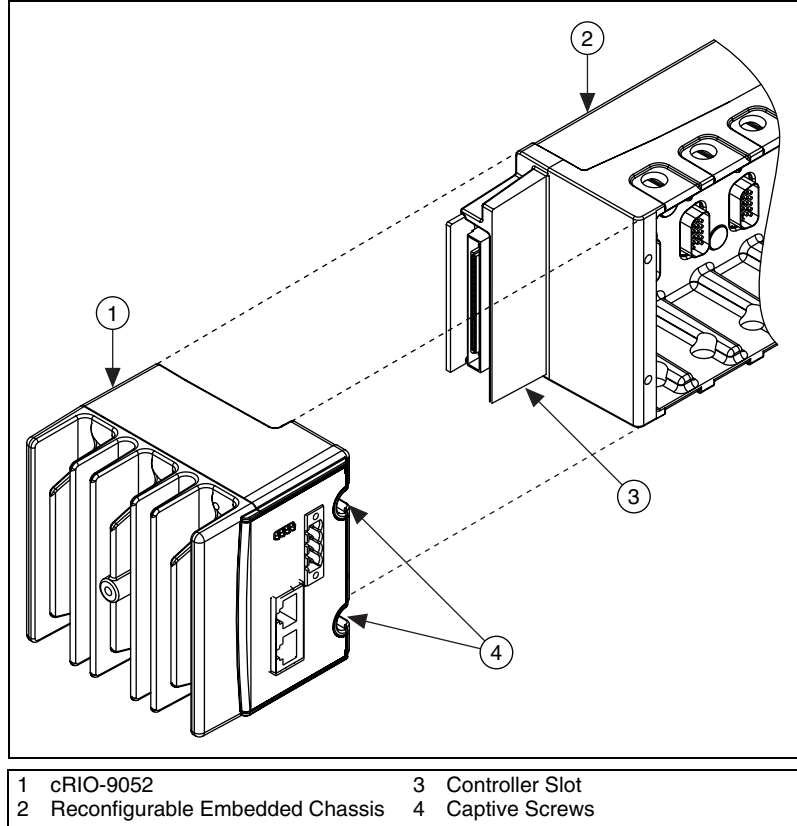

Figure 3. Installing the cRIO-9052 on the Chassis

3. Slide the cRIO-9052 onto the controller slot on the chassis. Press firmly to ensure the cRIO-9052 is seated properly on the reconfigurable chassis.

Refer to the *CompactRIO Reconfigurable Embedded System Installation Instructions* for more information about installing the cRIO-9052 onto the chassis.

4. Using a number 2 Phillips screwdriver, tighten the two captive screws on the front of the controller to $1.3 \text{ N} \cdot \text{m}$ (11.5 lb · in.) of torque.

Wiring Power to the cRIO-9052



Caution You *must* install the cRIO-9052 on a CompactRIO chassis and tighten the captive screws before you apply power to the cRIO-9052. Installing the cRIO-9052 while power is applied to it can cause damage to the chassis.

The cRIO-9052 requires an external power supply that meets the specifications in the *Power Requirements* section. The cRIO-9052 filters and regulates the supplied power and provides power for all of the I/O modules in the chassis. You can connect two power sources to the cRIO-9052, which draws power from the power source with the higher voltage. The cRIO-9052 has one layer of reversed-current flow protection. To conform to UL standards, the power source you connect to the cRIO-9052 must provide an additional layer of reversed-current flow protection.

Complete the following steps to connect power sources to the cRIO-9052:

1. Install a ferrite around the negative and positive wires for both the V1 and V2 terminals by wrapping both wires around one side of the ferrite one time. Refer to Figure 4 for an illustration of this step.
2. Connect the positive lead of one of the power sources to the V1 terminal and the negative lead to one of the C terminals.
3. Connect the positive lead of the other power source to the V2 terminal and the negative lead to one of the C terminals.



Note The cRIO-9052 draws power from *either* V1 or V2 depending on which terminal has a higher voltage. It does not draw power from both terminals.



Caution The C terminals are internally connected to each other. Make sure to use two power sources that have a common ground.

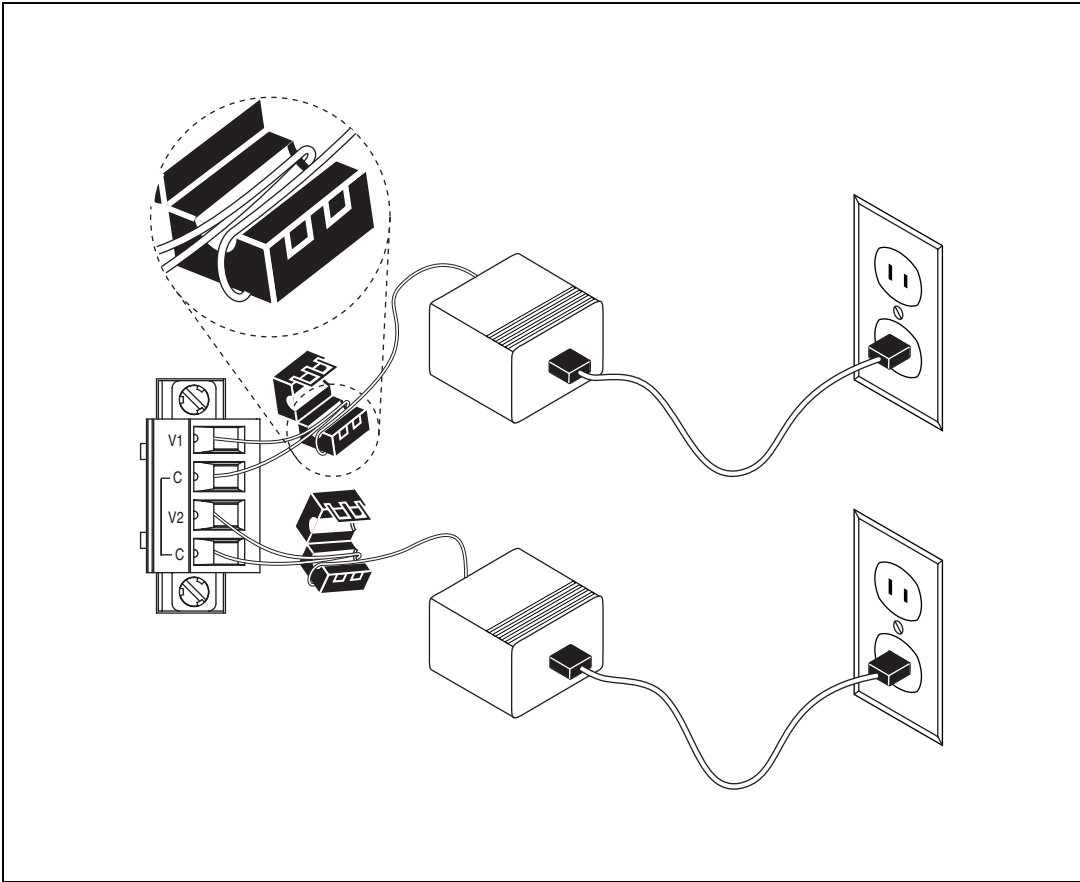

Figure 4. Wiring Power to the cRIO-9052

Wiring the cRIO-9052 for Connectivity to the Host

Connect each of the CAT5 Ethernet cables to the cRIO-9052. Note which cable is connected to the transmit (Tx) port and which cable is connected to the receive (Rx) port. You will need this information when you connect the other end of each of the cables to the appropriate ports on the NI 8310 that is installed in the host system. Refer to the [Install the NI 8310](#) section for more information about connecting the CAT5 Ethernet cables to the host system.

Driver Software

Refer to the following sections for information about installing driver software for the applicable hardware devices.

NI PXI-8310 and NI PCI-8310

If you are using the NI PXI-8310 or NI PCI-8310, it is not necessary to install any driver software for these devices. When you install the hardware devices, Windows will recognize three new devices. The reconfigurable chassis will be listed as the cRIO-91xx, and the cRIO-9052 and NI 8310 will each be listed as **Other PCI Bridge**. Windows will prompt you to install drivers for all three of these devices. Install the cRIO-91xx driver and cancel the driver installation for the cRIO-9052 and the NI 8310.

To prevent being prompted to install drivers every time you boot the Windows system, National Instruments recommends that you disable both of the **Other PCI Bridge** devices in the Windows device manager. The NI 8310 and the cRIO-9052 will continue to operate normally after you disable both of the **Other PCI Bridge** devices.



Note Installing the NI-CardBus-8310 driver software for use with the NI PXI-8310 and/or the NI PCI-8310 may cause improper operation.



Tip If you are using the NI 8310 with a host that is running the LabVIEW Real-Time Module, you will not be prompted to install any driver software.

NI CardBus-8310

If you are using the NI CardBus-8310, you must install the NI-CardBus-8310 driver software before you install the NI CardBus-8310. Refer to the *NI CardBus-8310-to-PXI Expansion User Manual* information about installing the NI-CardBus-8310 driver software.

Install the NI 8310

Refer to the following sections for information about installing the NI 8310.

NI PCI-8310

The NI PCI-8310 is a 64-bit PCI device. 64-bit PCI devices have a different connector than 32-bit PCI devices, but you can use a 64-bit PCI device in a PCI slot that is designed for a 32-bit PCI device. Refer to Figure 5 for more information.

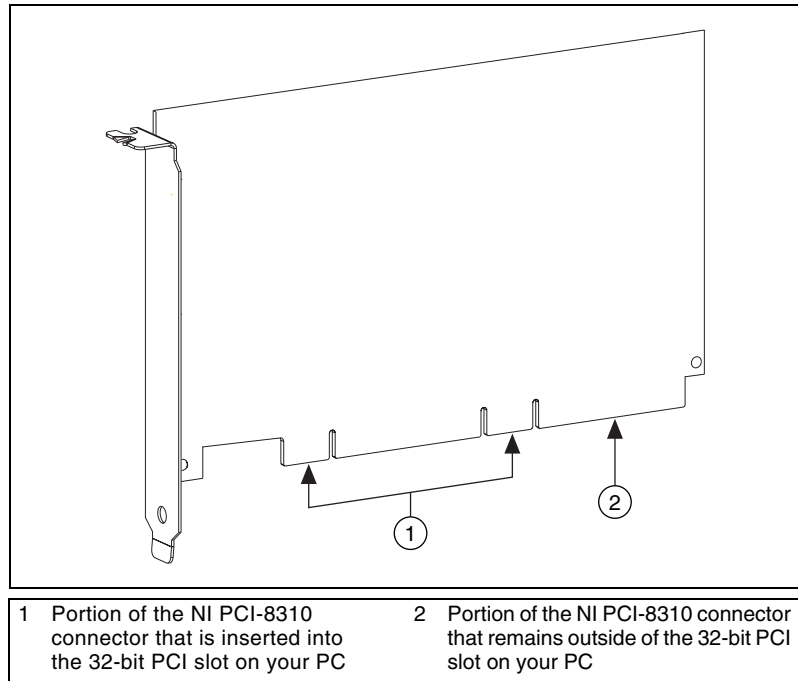

Figure 5. NI PCI-8310

Complete the following steps to install the NI PCI-8310:

1. Power off and unplug the computer.



Caution To protect yourself and the computer from electrical hazards, the computer *must* remain unplugged until the installation is complete.

2. Remove the cover to expose access to the PCI expansion slots.
3. Choose an unused PCI slot, and remove the corresponding expansion slot cover on the back panel of the computer.

4. Touch a metal part on the computer case to discharge any static electricity that might be on your clothes or body before handling the PCI-8310. Static electricity can damage the PCI-8310.
5. Gently rock the PCI-8310 into the slot. The connection may be tight, but do not force the PCI-8310 into place.
6. If required, screw the mounting bracket of the PCI-8310 to the back panel rail of the computer.
7. Replace the cover.
8. Make sure the cRIO-9052 is powered on and the CAT5 Ethernet cables are connected to the cRIO-9052. Refer to the [Wiring Power to the cRIO-9052](#) section for more information.



Note If you want the host to detect the CompactRIO reconfigurable chassis, which has the cRIO-9052 installed, without rebooting the host, you must power on the cRIO-9052 *before* you power on the host system.

9. Connect the CAT5 cable connected to the cRIO-9052 Rx port to the Tx port on the PCI-8310.
10. Connect the CAT5 cable connected to the cRIO-9052 Tx port to the Rx port on the PCI-8310.
11. Plug in and power on the computer.

If the Status LED does not light up on the cRIO-9052, refer to the [Understanding LED Indications](#) section to determine what might be wrong with the system.

NI CardBus-8310

Refer to the *NI CardBus-8310-to-PXI Expansion User Manual* for instructions for installing the NI CardBus-8310.

Complete the following steps to connect the NI CardBus-8310 to the cRIO-9052:

1. Make sure the cRIO-9052 is powered on and the CAT5 Ethernet cables are connected to the cRIO-9052. Refer to the [Wiring Power to the cRIO-9052](#) section for more information.
2. Connect the CAT5 cable connected to the cRIO-9052 Rx port to the Tx port on the CardBus-8310.
3. Connect the CAT5 cable connected to the cRIO-9052 Tx port to the Rx port on the CardBus-8310.
4. Plug in and turn on the laptop.

If the Status LED does not light up on the cRIO-9052, refer to the [Understanding LED Indications](#) section to determine what might be wrong with the system.

NI PXI-8310

Complete the following steps to install the NI PXI-8310:

1. Power off and unplug the PXI or CompactPCI chassis.
2. Choose an unused PXI or CompactPCI peripheral slot. Remove the filler panel for the peripheral slot you have chosen.
3. Touch a metal part on the chassis to discharge any static electricity that might be on your clothes or body.
4. Insert the PXI-8310 in the selected slot. Use the injector/ejector handle to fully inject the device into place.
5. Screw the front panel of the PXI-8310 to the front panel mounting rails of the PXI or CompactPCI chassis.
6. Visually verify the installation.
7. Make sure the cRIO-9052 is powered on and the CAT5 Ethernet cables are connected to the cRIO-9052. Refer to the [Wiring Power to the cRIO-9052](#) section for more information.



Note If you want the host to detect the CompactRIO reconfigurable chassis, which has the cRIO-9052 installed, without rebooting the host, you must power on the cRIO-9052 *before* you power on the host system.

8. Connect the CAT5 cable connected to the cRIO-9052 Rx port to the Tx port on the PXI-8310.
9. Connect the CAT5 cable connected to the cRIO-9052 Tx port to the Rx port on the PXI-8310.
10. Plug in and turn on the PXI or CompactPCI chassis.

If the Status LED does not light up on the cRIO-9052, refer to the [Understanding LED Indications](#) section to determine what might be wrong with the system.

Configure the CompactRIO Reconfigurable Chassis

On the host system, use MAX to configure the reconfigurable chassis.

To view information about how to configure the reconfigurable chassis in MAX, open MAX and click **Help»MAX Help**. In the help file, expand the **Installed Products** book in the **Contents** tab, and then expand the **CompactRIO** book.

Understanding LED Indications

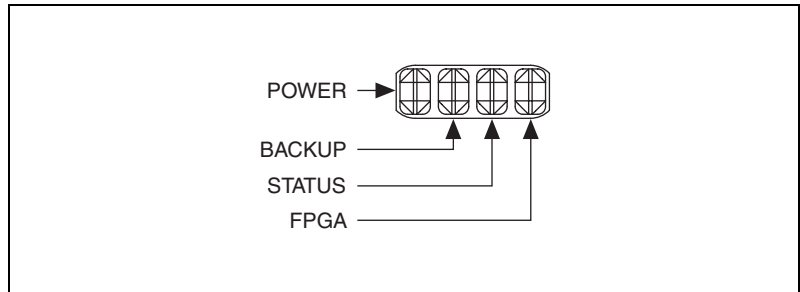

Figure 6. cRIO-9052 LEDs

Power LED

The Power LED is lit while the cRIO-9052 is powered on. This LED indicates that the power supply connected to the cRIO-9052 is adequate, and that the cRIO-9052 is supplying power to the CompactRIO system.

Backup LED

The Backup LED is lit when the cRIO-9052 is drawing power from the V2 terminal.

Status LED

The Status LED is on during normal operation. The cRIO-9052 indicates specific error conditions by turning off or flashing the Status LED.

If the Status LED is off, the NI 8310 and the cRIO-9052 are not connected properly. Unplug the CAT5 Ethernet cables from either the NI 8310 or the cRIO-9052, and swap the cable positions.

If the Status LED is flashing, the NI 8310 and the cRIO-9052 are connected properly. Reboot the host computer to ensure that the cRIO-9052 is properly enumerated and is running.

FPGA LED

You can use the FPGA LED to help debug the application or easily determine the status of the application. Use the LabVIEW FPGA Module and NI-RIO 2.0 or later to define the FPGA LED to meet the needs of the application. Refer to *LabVIEW Help* for information about programming this LED.

Specifications

StarFabric Communication

Interface4 LVDS transmit pairs
4 LVDS receive pairs

Communication rates

Theoretical maximum.....133 MB/s

Typical¹50 MB/s

Cabling requirements

Cables2 shielded
CAT5 Ethernet cables

Maximum difference between
the lengths of the two cables2.54 cm (1 in.)

Maximum cabling length.....14 m (45.93 ft)

Power Requirements

You must use a National Electric Code (NEC) Class 2 power source with the cRIO-9052.

Recommended power supply.....48 W secondary,
18 VDC to 24 VDC

Power consumption

cRIO-9052 only1.5 W, max

cRIO-9052 supplying power
to 8 CompactRIO modules17 W, max²

Power supply

On power up9 to 35 V

After power up.....6 to 35 V



Note The cRIO-9052 powers up only at 9 V or higher, but after it is powered up, it can run on as little as 6 V.

¹ This rate varies depending on your host system specifications, such as processor, RAM, and so on.

² This is the maximum amount of power that the entire system should consume at the power connector.

Physical Characteristics

If you need to clean the device, wipe it with a dry towel.

Screw-terminal wiring..... 12 to 24 AWG copper conductor wire with 10 mm (0.39 in.) of insulation stripped from the end

Torque for screw terminals 0.5 to 0.6 N · m
(4.4 to 5.3 lb · in.)

Weight..... Approx. 546 g (19.2 oz)

Safety

Safety Voltages

Connect only voltages that are within these limits.

V-to-C 35 V max,
Measurement Category I

Measurement Category I is for measurements performed on circuits not directly connected to the electrical distribution system referred to as *MAINS* voltage. *MAINS* is a hazardous live electrical supply system that powers equipment. This category is for measurements of voltages from specially protected secondary circuits. Such voltage measurements include signal levels, special equipment, limited-energy parts of equipment, circuits powered by regulated low-voltage sources, and electronics.

Safety Standards

The cRIO-9052 is designed to meet the requirements of the following standards of safety for electrical equipment for measurement, control, and laboratory use:

- EN 61010-1, IEC 61010-1
- UL 61010-1
- CAN/CSA-C22.2 No. 61010-1



Note For UL and other safety certifications, refer to the product label, or visit ni.com/certification, search by model number or product line, and click the appropriate link in the Certification column.

Environmental

The cRIO-9052 is intended for indoor use only. For outdoor use, mount the CompactRIO system in a suitably rated enclosure.

Operating temperature
(IEC 60068-2-1, IEC 60068-2-2)-40 to 70 °C



Note To meet this operating temperature range, follow the guidelines in the installation instructions for the CompactRIO system.

Storage temperature
(IEC 60068-2-1, IEC 60068-2-2)-40 to 85 °C

Ingress protectionIP 40

Operating humidity
(IEC 60068-2-56)10 to 90% RH, noncondensing

Storage humidity
(IEC 60068-2-56)5 to 95% RH, noncondensing

Maximum altitude.....2,000 m

Pollution Degree (IEC 60664).....2

Shock and Vibration

To meet these specifications, you must panel mount the CompactRIO system and affix ferrules to the end of the terminal wires.

Operating vibration

Random (IEC 60068-2-64).....5 g_{rms}, 10 to 500 Hz

Sinusoidal (IEC 60068-2-6)5 g, 10 to 500 Hz

Operating shock

(IEC 60068-2-27)30 g, 11 ms half sine

50 g, 3 ms half sine,

18 shocks at 6 orientations

Electromagnetic Compatibility

Emissions	EN 55011 Class A at 10 m FCC Part 15A above 1 GHz
Immunity	Industrial levels per EN 61326:1997 + A2:2001, Table A.1
EMC/EMI.....	CE, C-Tick, and FCC Part 15 (Class A) Compliant



Note For EMC compliance, operate this device with shielded cabling.

CE Compliance

This product meets the essential requirements of applicable European directives, as amended for CE marking, as follows:

Low-Voltage Directive (safety) 73/23/EEC

Electromagnetic Compatibility
Directive (EMC) 89/336/EEC



Note Refer to the Declaration of Conformity (DoC) for this product for any additional regulatory compliance information. To obtain the DoC for this product, visit ni.com/certification, search by model number or product line, and click the appropriate link in the Certification column.

Where to Go for Support

The National Instruments Web site is your complete resource for technical support. At ni.com/support you have access to everything from troubleshooting and application development self-help resources to email and phone assistance from NI Application Engineers.

National Instruments corporate headquarters is located at 11500 North Mopac Expressway, Austin, Texas, 78759-3504. National Instruments also has offices located around the world to help address your support needs. For telephone support in the United States, create your service request at ni.com/support and follow the calling instructions or dial 512 795 8248. For telephone support outside the United States, contact your local branch office:

Australia 1800 300 800, Austria 43 0 662 45 79 90 0,
Belgium 32 0 2 757 00 20, Brazil 55 11 3262 3599,
Canada 800 433 3488, China 86 21 6555 7838,
Czech Republic 420 224 235 774, Denmark 45 45 76 26 00,
Finland 385 0 9 725 725 11, France 33 0 1 48 14 24 24,
Germany 49 0 89 741 31 30, India 91 80 51190000,
Israel 972 0 3 6393737, Italy 39 02 413091, Japan 81 3 5472 2970,
Korea 82 02 3451 3400, Lebanon 961 0 1 33 28 28,
Malaysia 1800 887710, Mexico 01 800 010 0793,
Netherlands 31 0 348 433 466, New Zealand 0800 553 322,
Norway 47 0 66 90 76 60, Poland 48 22 3390150,
Portugal 351 210 311 210, Russia 7 095 783 68 51,
Singapore 1800 226 5886, Slovenia 386 3 425 4200,
South Africa 27 0 11 805 8197, Spain 34 91 640 0085,
Sweden 46 0 8 587 895 00, Switzerland 41 56 200 51 51,
Taiwan 886 02 2377 2222, Thailand 662 278 6777,
United Kingdom 44 0 1635 523545

National Instruments, NI, ni.com, and LabVIEW are trademarks of National Instruments Corporation. Refer to the *Terms of Use* section on ni.com/legal for more information about National Instruments trademarks. Other product and company names mentioned herein are trademarks or trade names of their respective companies. For patents covering National Instruments products, refer to the appropriate location: **Help»Patents** in your software, the `patents.txt` file on your CD, or ni.com/patents.