

OPERATING INSTRUCTIONS AND SPECIFICATIONS

NI 9401

8-Channel, TTL Digital Input/Output Module

Français Deutsch 日本語 한국어 简体中文

ni.com/manuals

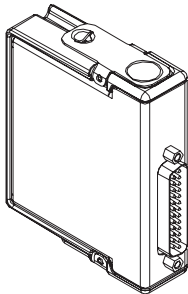

This document describes how to use the National Instruments 9401 and includes specifications and pin assignments for the NI 9401. Visit ni.com/info and enter `rdsoftwareversion` to determine which software you need for the modules you are using. For information about installing, configuring, and programming the system, refer to the system documentation. Visit ni.com/info and enter `cseriesdoc` for information about C Series documentation.



Note The safety guidelines and specifications in this document are specific to the NI 9401. The other components in the system might not meet the same safety ratings and specifications. Refer to the documentation for each component in the system to determine the safety ratings and specifications for the entire system. Visit ni.com/info and enter `cseriesdoc` for information about C Series documentation.

Safety Guidelines

Operate the NI 9401 only as described in these operating instructions.



Hot Surface This icon denotes that the component may be hot. Touching this component may result in bodily injury.

Safety Guidelines for Hazardous Locations

The NI 9401 is suitable for use in Class I, Division 2, Groups A, B, C, D, T4 hazardous locations; Class I, Zone 2, AEx nC IIC T4, and Ex nC IIC T4 hazardous locations; and nonhazardous locations only. Follow these guidelines if you are installing the NI 9401 in a potentially explosive environment. Not following these guidelines may result in serious injury or death.



Caution Do *not* disconnect I/O-side wires or connectors unless power has been switched off or the area is known to be nonhazardous.



Caution Do *not* remove modules unless power has been switched off or the area is known to be nonhazardous.



Caution Substitution of components may impair suitability for Class I, Division 2.



Caution For Zone 2 applications, install the system in an enclosure rated to at least IP 54 as defined by IEC 60529 and EN 60529.



Caution For Zone 2 applications, connected signals must be within the following limit:

Capacitance 0.2 μ F max

Special Conditions for Hazardous Locations Use in Europe

This equipment has been evaluated as EEx nC IIC T4 equipment under DEMKO Certificate No. 03 ATEX 0324020X. Each module is marked Ex II 3G and is suitable for use in Zone 2 hazardous locations. If you are using the NI 9401 in Gas Group IIC hazardous locations or in ambient temperatures of $-40\text{ }^{\circ}\text{C} \leq T_a \leq 70\text{ }^{\circ}\text{C}$, you must use the device in an NI chassis that has been evaluated as EEx nC IIC T4, Ex nA IIC T4, or Ex nL IIC T4 equipment.

Special Conditions for Marine Applications

Some modules are Lloyd's Register (LR) Type Approved for marine applications. To verify Lloyd's Register certification, visit ni.com/certification and search for the LR certificate, or look for the Lloyd's Register mark on the module.



Caution To meet radio frequency emission requirements for marine applications, use shielded cables and install the system in a metal enclosure. Suppression ferrites must be installed on power supply inputs near power entries to modules and controllers. Power supply and module cables must be separated on opposite sides of the enclosure and must enter and exit through opposing enclosure walls.

Connecting the NI 9401

The NI 9401 has a 25-pin DSUB connector that provides connections for eight digital input/output channels.

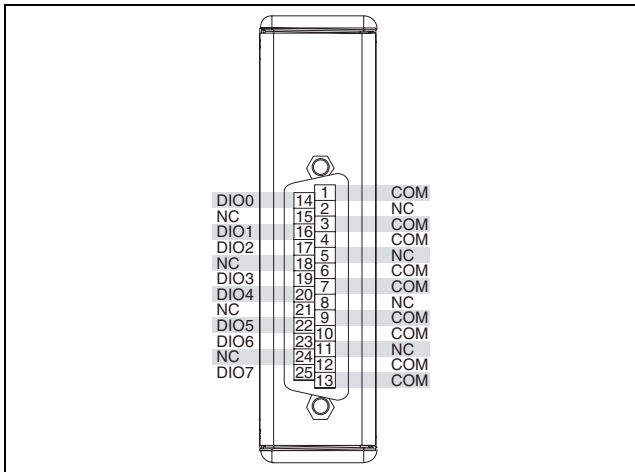

Figure 1. NI 9401 Pin Assignments

Each channel has a DIO pin to which you can connect a digital input or output device. The eight DIO channels are internally referenced to COM, so you can use any of the nine COM lines as a reference for the external signal.

The DIO channels are grouped in two ports, one containing channels 0, 1, 2, and 3, and one containing channels 4, 5, 6, and 7. You can independently configure each digital port in software for input or output. Note that all four channels in the port must share the same line direction. Refer to the software help for information about configuring ports on the NI 9401.

Each channel also has a pull-down resistor and includes overvoltage, overcurrent, and short-circuit protection. Refer to the *Specifications* section for more information about input thresholds and overvoltage protection. Refer to the *Overcurrent Protection* section for more information about overcurrent protection.

Figure 2 illustrates how to connect an SPI device to the NI 9401. In this example, the three channels assigned to output signals are on one port and the channel assigned to an input signal is on the other port.

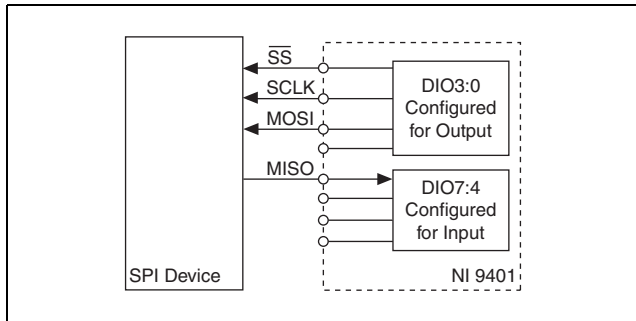

Figure 2. Connecting an SPI Device to the NI 9401

Figure 3 illustrates how to connect several types of digital devices to the NI 9401.

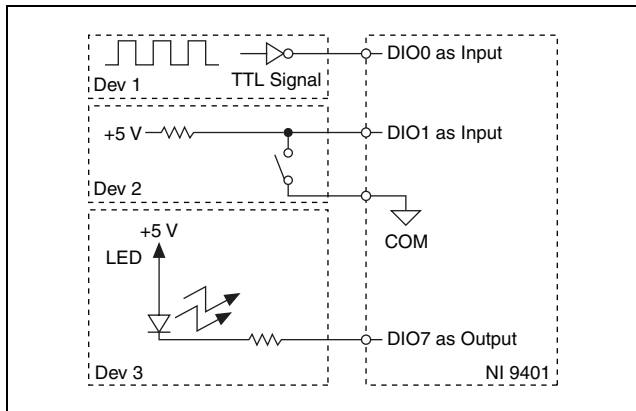

Figure 3. Connecting Digital Devices to the NI 9401

Overcurrent Protection

Overcurrent protection on the NI 9401 allows only a specified amount of current for switching DIO channels or sourcing the output load. If the NI 9401 goes into an overcurrent state, by exceeding the specified maximum switching frequency or the output load, the module power supply begins to drop in voltage until it completely turns off or the overcurrent condition is removed. When the module is in this state, it can accept new line direction configuration and output state data but cannot pass valid input data to the software. Refer to the *Specifications* section for more information about the maximum switching frequency and output load for each channel.

Sleep Mode

This module supports a low-power sleep mode. Support for sleep mode at the system level depends on the chassis that the module is plugged into. Refer to the chassis manual for information about support for sleep mode. If the chassis supports sleep mode, refer to the software help for information about enabling sleep mode. Visit ni.com/info and enter `cseriesdoc` for information about C Series documentation.

Typically, when a system is in sleep mode, you cannot communicate with the modules. In sleep mode, the system consumes minimal power and may dissipate less heat than it does in normal mode. Refer to the *Specifications* section for more information about power consumption and thermal dissipation.

Specifications

The following specifications are typical for the range -40 to 70 °C unless otherwise noted. All voltages are relative to COM unless otherwise noted.

Input/Output Characteristics

Number of channels	8 DIO channels
Default power-on line direction	Input
Input/output type.....	TTL, single-ended

Digital logic levels

Input

Voltage 5.25 V max

High, V_{IH} 2 V min

Low, V_{IL} 0.8 V max

Output

High, V_{OH} 5.25 V max

Sourcing 100 μ A 4.7 V min

Sourcing 2 mA 4.3 V min

Low, V_{OL}

Sinking 100 μ A 0.1 V max

Sinking 2 mA 0.4 V max

Maximum input signal switching frequency by number of input channels, per channel

8 input channels.....	9 MHz
4 input channels.....	16 MHz
2 input channels.....	30 MHz

Maximum output signal switching frequency by number of output channels with an output load of 1 mA, 50 pF, per channel

8 output channels.....	5 MHz
4 output channels.....	10 MHz
2 output channels.....	20 MHz

I/O propagation delay 100 ns max

I/O pulse width distortion 10 ns typ

Input current ($0\text{ V} \leq V_{in} \leq 4.5\text{ V}$)..... $\pm 250\text{ }\mu\text{A}$ typ

Input capacitance 30 pF typ

Input rise/fall time..... 500 ns max

Overvoltage protection,

channel-to-COM $\pm 30\text{ V}$ max on one channel at a time; however, continued use at this level will degrade the life of the module.

MTBF 1,244,763 hours at 25 °C;
Bellcore Issue 2, Method 1,
Case 3, Limited Part Stress
Method



Note Contact NI for Bellcore MTBF specifications at other temperatures or for MIL-HDBK-217F specifications.

Power Requirements

Power consumption from chassis

Active mode 580 mW max

Sleep mode 1 mW max

Thermal dissipation (at 70 °C)

Active mode 580 mW max

Sleep mode 1 mW max

Physical Characteristics

If you need to clean the module, wipe it with a dry towel.

Weight 145 g (5.1 oz)

Safety

Maximum Voltage¹

Connect only voltages that are within the following limits.

Channel-to-COM ± 30 V max on one channel
at a time, Measurement
Category I

Isolation Voltages

Channel-to-channel None

Channel-to-earth ground

Continuous 60 VDC, Measurement
Category I

Withstand 1,000 V_{rms}, verified by a 5 s
dielectric withstand test

Measurement Category I is for measurements performed on circuits not directly connected to the electrical distribution system referred to as *MAINS* voltage. *MAINS* is a hazardous live electrical

¹ The maximum voltage that can be applied or output between any channel and COM without damaging the module or other devices.

supply system that powers equipment. This category is for measurements of voltages from specially protected secondary circuits. Such voltage measurements include signal levels, special equipment, limited-energy parts of equipment, circuits powered by regulated low-voltage sources, and electronics.



Caution Do *not* connect the NI 9401 to signals or use for measurements within Measurement Categories II, III, or IV.

Safety Standards

This product is designed to meet the requirements of the following standards of safety for electrical equipment for measurement, control, and laboratory use:

- IEC 61010-1, EN 61010-1
- UL 61010-1, CSA 61010-1



Note For UL and other safety certifications, refer to the product label or visit ni.com/certification, search by module number or product line, and click the appropriate link in the Certification column.

Hazardous Locations

U.S. (UL)	Class I, Division 2, Groups A, B, C, D, T4; Class I, Zone 2, AEx nC IIC T4
Canada (C-UL)	Class I, Division 2, Groups A, B, C, D, T4; Class I, Zone 2, Ex nC IIC T4
Europe (DEMKO).....	EEx nC IIC T4

Environmental

National Instruments C Series modules are intended for indoor use only but may be used outdoors if installed in a suitable enclosure. Refer to the manual for the chassis you are using for more information about meeting these specifications.

Operating temperature
(IEC 60068-2-1, IEC 60068-2-2) -40 to 70 °C

Storage temperature
(IEC 60068-2-1, IEC 60068-2-2) -40 to 85 °C

Ingress protection..... IP 40

Operating humidity
(IEC 60068-2-56)..... 10 to 90% RH,
noncondensing

Storage humidity
(IEC 60068-2-56)..... 5 to 95% RH,
noncondensing

Maximum altitude..... 2,000 m

Pollution Degree (IEC 60664) 2

Shock and Vibration

To meet these specifications, you must panel mount the system.

Operating vibration

Random (IEC 60068-2-64)..... 5 g_{rms} , 10 to 500 Hz

Sinusoidal (IEC 60068-2-6) 5 g, 10 to 500 Hz

Operating shock

(IEC 60068-2-27)..... 30 g, 11 ms half sine,
50 g, 3 ms half sine,
18 shocks at 6 orientations

Electromagnetic Compatibility

This product is designed to meet the requirements of the following standards of EMC for electrical equipment for measurement, control, and laboratory use:

- EN 61326 EMC requirements; Industrial Immunity
- EN 55011 Emissions; Group 1, Class A
- CE, C-Tick, ICES, and FCC Part 15 Emissions; Class A



Note For EMC compliance, operate this device with shielded cabling.

CE Compliance

This product meets the essential requirements of applicable European directives, as amended for CE markings, as follows:

- 2006/95/EC; Low-Voltage Directive (safety)
- 2004/108/EC; Electromagnetic Compatibility Directive (EMC)



Note Refer to the Declaration of Conformity (DoC) for this product for any additional regulatory compliance information. To obtain the DoC for this product, visit

ni.com/certification, search by module number or product line, and click the appropriate link in the Certification column.

Environmental Management

National Instruments is committed to designing and manufacturing products in an environmentally responsible manner. NI recognizes that eliminating certain hazardous substances from our products is beneficial not only to the environment but also to NI customers.

For additional environmental information, refer to the *NI and the Environment* Web page at ni.com/environment. This page contains the environmental regulations and directives with which NI complies, as well as other environmental information not included in this document.

Waste Electrical and Electronic Equipment (WEEE)



EU Customers At the end of their life cycle, all products *must* be sent to a WEEE recycling center. For more information about WEEE recycling centers and National Instruments WEEE initiatives, visit ni.com/environment/weee.htm.

电子信息产品污染控制管理办法（中国 RoHS）



中国客户 National Instruments 符合中国电子信息产品中限制使用某些有害物质指令 (RoHS)。关于 National Instruments 中国 RoHS 合规性信息，请登录 ni.com/environment/rohs_china。(For information about China RoHS compliance, go to ni.com/environment/rohs_china.)

Where to Go for Support

The National Instruments Web site is your complete resource for technical support. At ni.com/support you have access to everything from troubleshooting and application development self-help resources to email and phone assistance from NI Application Engineers.

National Instruments corporate headquarters is located at 11500 North Mopac Expressway, Austin, Texas, 78759-3504. National Instruments also has offices located around the world to help address your support needs. For telephone support in the United States, create your service request at ni.com/support and follow the calling instructions or dial 512 795 8248. For

telephone support outside the United States, contact your local branch office:

Australia 1800 300 800, Austria 43 662 457990-0,
Belgium 32 (0) 2 757 0020, Brazil 55 11 3262 3599,
Canada 800 433 3488, China 86 21 5050 9800,
Czech Republic 420 224 235 774, Denmark 45 45 76 26 00,
Finland 358 (0) 9 725 72511, France 01 57 66 24 24,
Germany 49 89 7413130, India 91 80 41190000,
Israel 972 3 6393737, Italy 39 02 41309277, Japan 0120-527196,
Korea 82 02 3451 3400, Lebanon 961 (0) 1 33 28 28,
Malaysia 1800 887710, Mexico 01 800 010 0793,
Netherlands 31 (0) 348 433 466, New Zealand 0800 553 322,
Norway 47 (0) 66 90 76 60, Poland 48 22 3390150,
Portugal 351 210 311 210, Russia 7 495 783 6851,
Singapore 1800 226 5886, Slovenia 386 3 425 42 00,
South Africa 27 0 11 805 8197, Spain 34 91 640 0085,
Sweden 46 (0) 8 587 895 00, Switzerland 41 56 2005151,
Taiwan 886 02 2377 2222, Thailand 662 278 6777,
Turkey 90 212 279 3031, United Kingdom 44 (0) 1635 523545

National Instruments, NI, ni.com, and LabVIEW are trademarks of National Instruments Corporation. Refer to the *Terms of Use* section on ni.com/legal for more information about National Instruments trademarks. Other product and company names mentioned herein are trademarks or trade names of their respective companies. For patents covering National Instruments products, refer to the appropriate location: **Help » Patents** in your software, the `patents.txt` file on your media, or ni.com/patents.

© 2005–2008 National Instruments Corp. All rights reserved.