

INSTALLATION GUIDE

NI PXI-2585/2586 Connector and Backshell Kit

This document describes how to create and install a cable that connects high current signals to the NI PXI-2585 or NI PXI-2586 switch module.

Introduction

The connector and backshell kit for the PXI-2585/2586 switch module contains all of the components necessary to build a cable assembly that is safe for use with the entire operating range of the PXI-2585/2586 series of products. Read through this installation guide carefully to ensure that the cable you build is safe to use with your switch module.



Caution When hazardous voltages ($>42.4 V_{pk}/60 \text{ VDC}$) are present on any solder cup pin, safety low-voltage ($\leq 42.4 V_{pk}/60 \text{ VDC}$) cannot be connected to any other solder cup pin.

The PXI-2585/2586 connector and backshell kit contains the following:

- Empty metal backshell
- Solder cup pins (Qty. 22)
- 0.050 in. Allen wrench
- Polyimide tape

You must supply the following items to complete the construction of the cable:

- Soldering iron
- 16 AWG stranded wire



Caution If your cable assembly will be used in high-voltage applications ($>42.4 V_{pk}/60 \text{ VDC}$), you *must* use UL style 2464 approved cable.

- Specifications for the module with which the cable will be used



Note The *NI PXI-2585/2586 Specifications* contains the pinout diagram necessary to build the cable. Visit ni.com/manuals for the most current specifications for your PXI-2585/2586 switch module.



Caution You *must* install this connector and backshell assembly according to local safety codes and standards and according to the specifications provided by the connector manufacturer. You are responsible for verifying safety compliance of third-party connectors and their usage according to the relevant standard(s), including UL and CSA in North America and IEC and VDE in Europe.

Constructing the Cable

Complete the following steps to construct a cable assembly designed to meet high-voltage requirements ($>42.4 V_{pk}/60$ VDC).



Note If your cable assembly will be used only in low-voltage applications, the use of UL style 2464 approved insulated cable is unnecessary. Proceed directly to step 2 to construct a cable assembly for low-voltage applications.

1. Remove 1 in. of outer insulation from the UL style 2464 approved cable.
2. Strip 0.2 in. (5.1 mm) of insulation from the end of each conductor.
3. Fully insert the stripped portion of each conductor into one of the solder cup pins provided with the kit. If the conductor has been inserted correctly, you will be able to see it through the opening in the pin.
4. Solder each conductor to the pin by heating the conductor through the opening of the pin. Ensure that the finished solder does not protrude out of the opening in the pin.

Figure 1 illustrates the components of your backshell assembly.

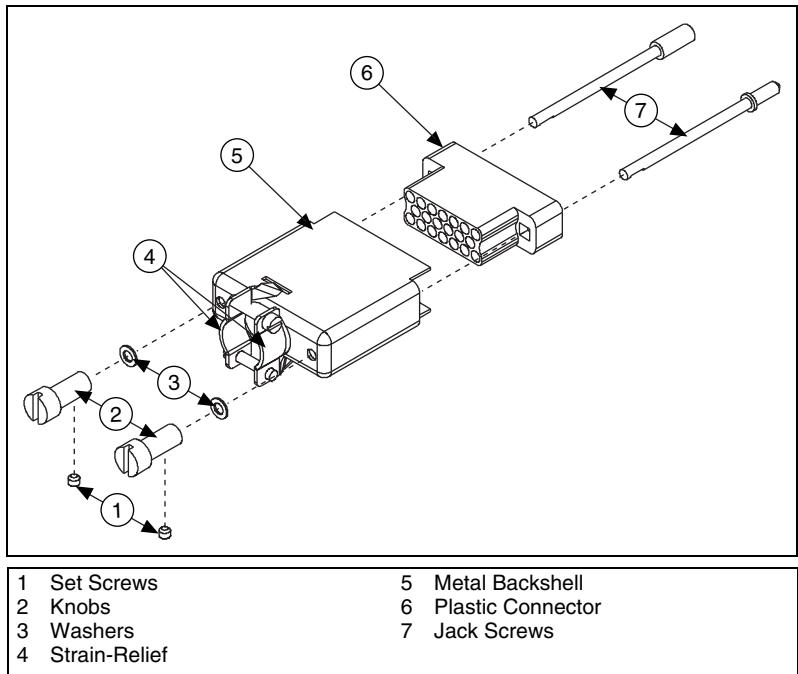

Figure 1. Connector and Backshell for the PXI-2585/2586

5. Remove the set screws from the knobs of the jack screws using the Allen wrench.
6. Loosen the strain-relief bracket until it is fully open.
7. Remove the metal backshell from the plastic connector.

8. Route all the conductors through the backshell as illustrated in Figure 2.

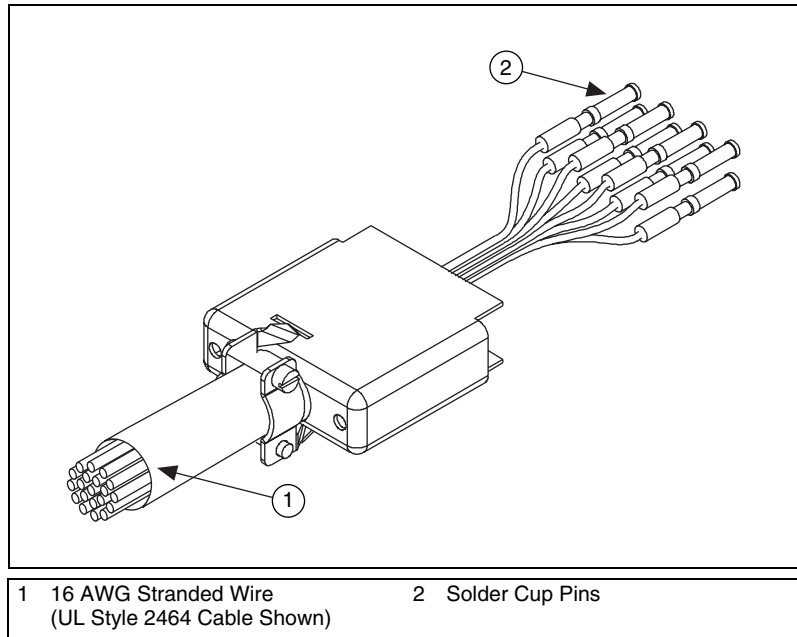

Figure 2. Backshell with Threaded Wires

9. Refer to the front panel pinout diagram in your module specifications. Use this diagram to insert the solder cup pins (with conductors attached) into the connector. Solder cup pins will snap into place when inserted correctly, as shown in Figure 3.



Note The letters on the backshell connector match the letters on the module. For example, connector position “A” on your PXI-2585/2586 switch module will mate with the connector in position “A” on the backshell kit.



Note Take care to insert the pin into the correct connector position. Once the pin is inserted, it can only be removed from the connector with an extraction tool. Extraction tools must be purchased separately.

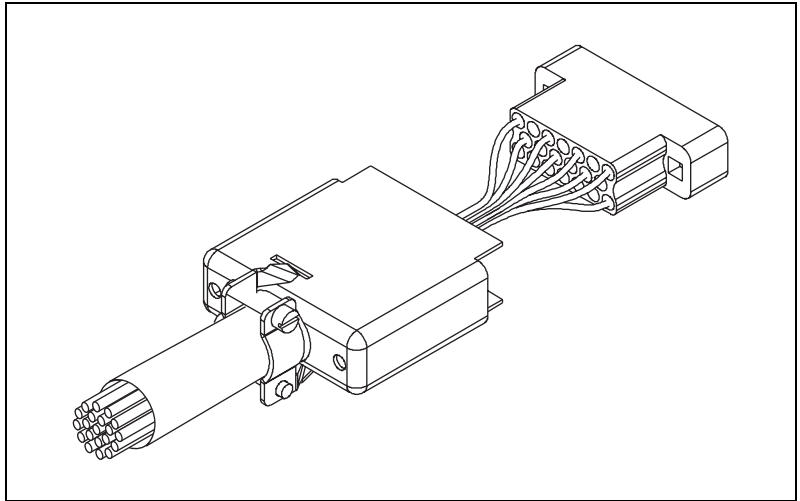

Figure 3. Connector with Inserted Solder Cup Pins

10. Cut 10 in. of polyimide tape from the roll provided. Wrap the tape around the connector twice near the interface between the conductors and the connector. The connector should now look like Figure 4.



Caution The polyimide tape must be installed per these instructions or your cable will only be rated to 42.4 V_{pk}/60 VDC.

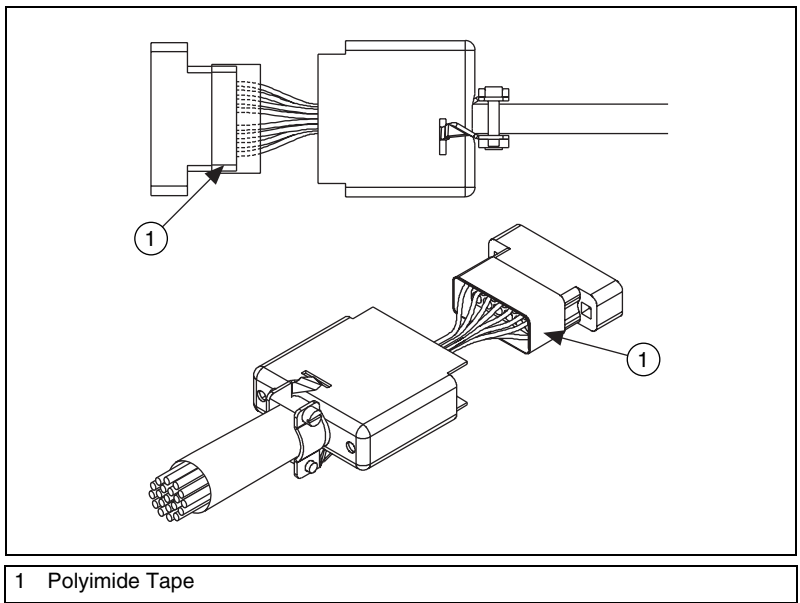

Figure 4. Connector Wrapped with Polyimide Tape

11. Reassemble the connector and backshell. Slide the backshell up the cable, and tighten the strain-relief.



Note Replace the jack screw shaped like a socket nearest to pin “U” of the connector. Insert the male jack screw nearest to pin “A” of the connector to ensure proper mating.

Accessories

Table 1. Optional Third-Party Accessories for the NI PXI-2585/2586 Connector and Backshell Kit

Accessory	Manufacturer	Part Number
Contact insertion tool	Positronic	9099
Contact extraction tool	Positronic	9081

National Instruments, NI, ni.com, and LabVIEW are trademarks of National Instruments Corporation. Refer to the *Terms of Use* section on ni.com/legal for more information about National Instruments trademarks. Other product and company names mentioned herein are trademarks or trade names of their respective companies. For patents covering National Instruments products, refer to the appropriate location: **Help»Patents** in your software, the `patents.txt` file on your CD, or ni.com/patents.