

INSTALLATION INSTRUCTIONS

NI TB-2630

Terminal Block for the NI PXI-2530

This guide describes how to install and connect signals to the National Instruments TB-2630 terminal block to configure your NI PXI-2530 switch module as one of the following:

- 128 × 1 1-wire multiplexer
- 64 × 1 2-wire multiplexer
- 32 × 1 4-wire multiplexer
- Eight 16 × 1 1-wire multiplexers

Refer to the *NI Switches Getting Started Guide* to determine when to install the terminal block.

Introduction

The TB-2630 terminal block installs in front of the PXI-2530 switch module. The TB-2630 has ribbon cable headers to connect signals to the switch. Screw terminals for the trigger input and trigger output signals also are available.

Conventions

The following conventions are used in this guide:

»

The » symbol leads you through nested menu items and dialog box options to a final action. The sequence **File»Page Setup»Options** directs you to pull down the **File** menu, select the **Page Setup** item, and select **Options** from the last dialog box.



This icon denotes a note, which alerts you to important information.



This icon denotes a caution, which advises you of precautions to take to avoid injury, data loss, or a system crash.

| | |
|---------------|---|
| bold | Bold text denotes items that you must select or click in the software, such as menu items and dialog box options. Bold text also denotes parameter names. |
| <i>italic</i> | Italic text denotes variables, emphasis, a cross reference, or an introduction to a key concept. This font also denotes text that is a placeholder for a word or value that you must supply. |
| monospace | Text in this font denotes text or characters that you should enter from the keyboard, sections of code, programming examples, and syntax examples. This font is also used for the proper names of disk drives, paths, directories, programs, subprograms, subroutines, device names, functions, operations, variables, filenames, and extensions. |

1. Unpack the Terminal Block

To avoid damage when you handle the terminal block, take the following precautions:



Caution *Never* touch the exposed pins of connectors.

- Ground yourself using a grounding strap or by touching a grounded object.
- Touch the antistatic package to a metal part of the chassis before you remove the terminal block from the package.

Remove the terminal block from the package and inspect the terminal block for loose components or any sign of damage. Notify NI if the terminal block appears damaged in any way. Do *not* install a damaged terminal block on a switch terminal block.

Store the terminal block in the antistatic package when not in use.

2. Verify the Components

Make sure you have the following:

- NI TB-2630 terminal block
- PXI chassis
- NI PXI-2530 switch module
- 1/8 in. flathead screwdriver
- Eight 2 × 9, 0.100 in. pitch ribbon cable connectors (included)
- 18-conductor, 28 AWG, 0.050 in. pitch ribbon cable (not included)

3. Connect Signals

To connect signals to the terminal block, complete the following steps:

1. Remove the terminal block top cover screws with the flathead screwdriver.
2. Gently lift the terminal block top cover off the terminal block.
3. Loosen the two screws on the strain-relief assembly and remove the top strain-relief bar.
4. Prepare your ribbon cable by installing the 2 × 9 ribbon cable connectors onto separate 18-conductor ribbon cables.
5. Connect each ribbon cable to a header.
6. Replace the strain-relief bar and tighten the two screws on the strain-relief assembly to secure the cables.
7. Replace the terminal block top cover.
8. Secure the terminal block top cover with the top cover screws.

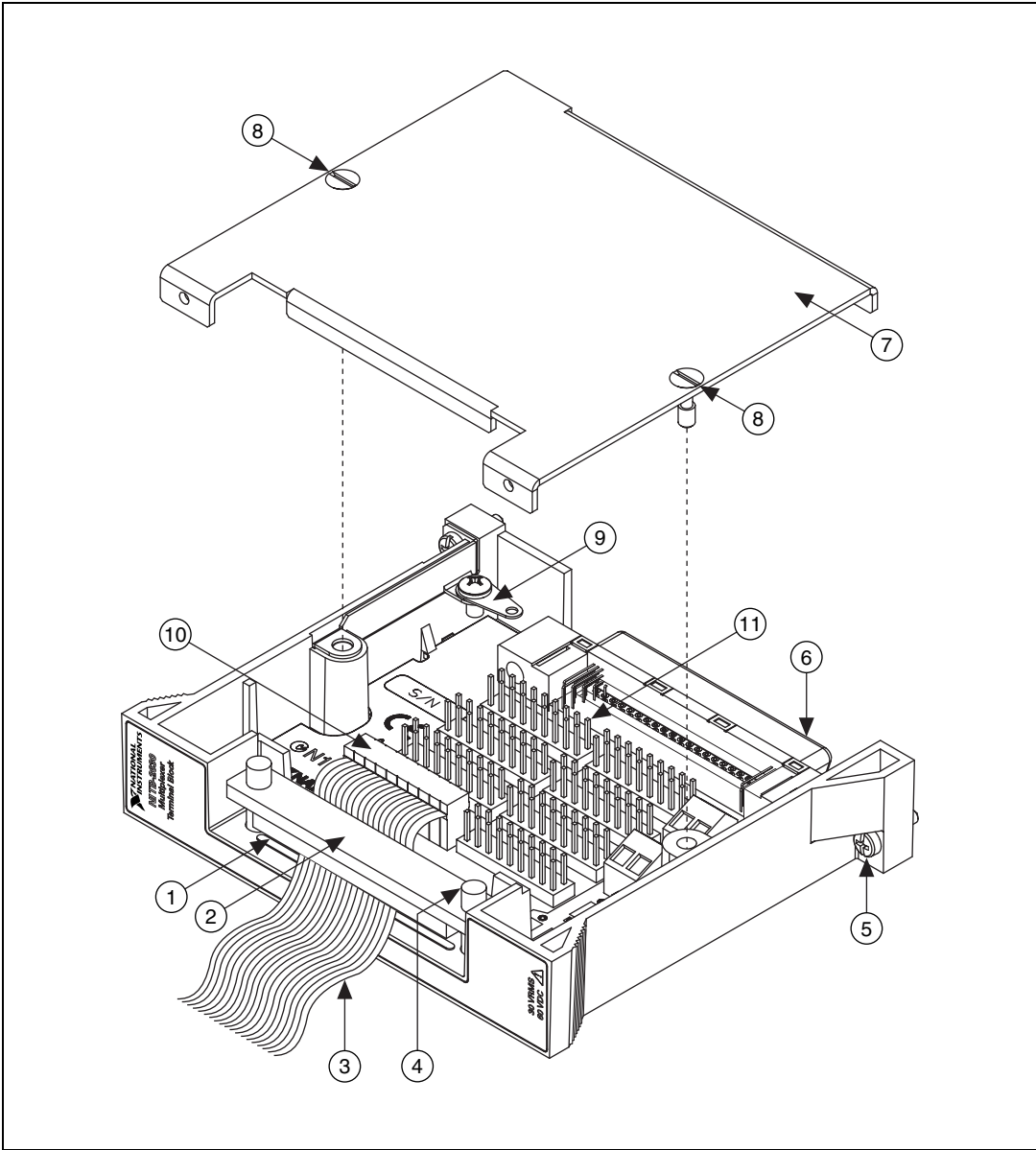

- | | |
|-------------------------|----------------------------|
| 1 Strain-Relief Opening | 7 Terminal Block Top Cover |
| 2 Strain-Relief Bar | 8 Top Cover Screws |
| 3 Ribbon Cable | 9 Safety Ground Lug |
| 4 Strain-Relief Screw | 10 Ribbon Cable Connector |
| 5 Chassis Screws | 11 Ribbon Cable Header |
| 6 Rear Connector | |

Figure 1. TB-2630 Terminal Block

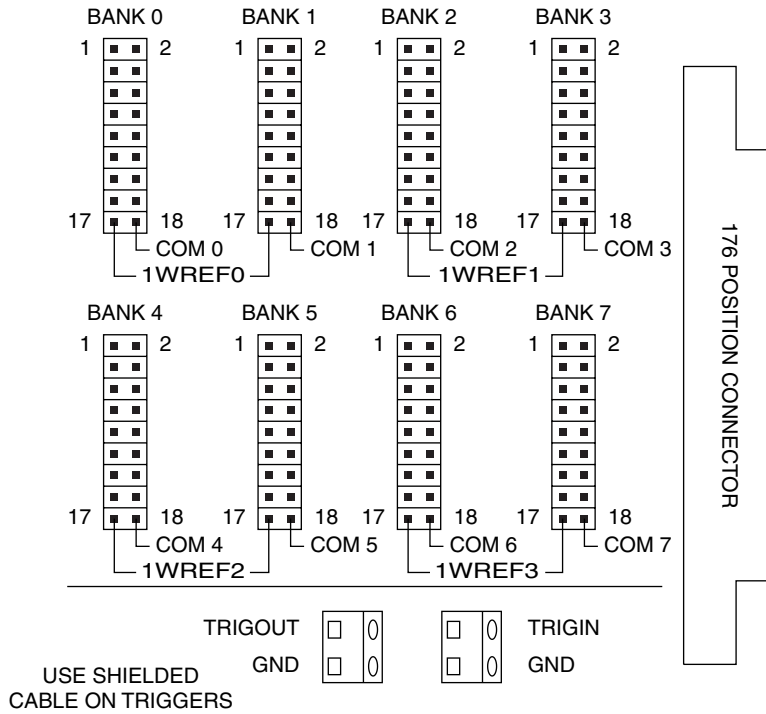

Figure 2. TB-2630 Terminal Block Signal Connections

Table 1. 128 x 1, 1-Wire Topology Terminal Mapping

| Software Name | Hardware Name | Software Name | Hardware Name | Software Name | Hardware Name |
|---------------|----------------|---------------|----------------|---------------|----------------|
| com0 | BANK 0, PIN 18 | ch42 | BANK 2, PIN 11 | ch85 | BANK 5, PIN 6 |
| ch0 | BANK 0, PIN 1 | ch43 | BANK 2, PIN 12 | ch86 | BANK 5, PIN 7 |
| ch1 | BANK 0, PIN 2 | ch44 | BANK 2, PIN 13 | ch87 | BANK 5, PIN 8 |
| ch2 | BANK 0, PIN 3 | ch45 | BANK 2, PIN 14 | ch88 | BANK 5, PIN 9 |
| ch3 | BANK 0, PIN 4 | ch46 | BANK 2, PIN 15 | ch89 | BANK 5, PIN 10 |
| ch4 | BANK 0, PIN 5 | ch47 | BANK 2, PIN 16 | ch90 | BANK 5, PIN 11 |
| ch5 | BANK 0, PIN 6 | ch48 | BANK 3, PIN 1 | ch91 | BANK 5, PIN 12 |
| ch6 | BANK 0, PIN 7 | ch49 | BANK 3, PIN 2 | ch92 | BANK 5, PIN 13 |
| ch7 | BANK 0, PIN 8 | ch50 | BANK 3, PIN 3 | ch93 | BANK 5, PIN 14 |
| ch8 | BANK 0, PIN 9 | ch51 | BANK 3, PIN 4 | ch94 | BANK 5, PIN 15 |
| ch9 | BANK 0, PIN 10 | ch52 | BANK 3, PIN 5 | ch95 | BANK 5, PIN 16 |
| ch10 | BANK 0, PIN 11 | ch53 | BANK 3, PIN 6 | ch96 | BANK 6, PIN 1 |
| ch11 | BANK 0, PIN 12 | ch54 | BANK 3, PIN 7 | ch97 | BANK 6, PIN 2 |
| ch12 | BANK 0, PIN 13 | ch55 | BANK 3, PIN 8 | ch98 | BANK 6, PIN 3 |
| ch13 | BANK 0, PIN 14 | ch56 | BANK 3, PIN 9 | ch99 | BANK 6, PIN 4 |
| ch14 | BANK 0, PIN 15 | ch57 | BANK 3, PIN 10 | ch100 | BANK 6, PIN 5 |
| ch15 | BANK 0, PIN 16 | ch58 | BANK 3, PIN 11 | ch101 | BANK 6, PIN 6 |
| ch16 | BANK 1, PIN 1 | ch59 | BANK 3, PIN 12 | ch102 | BANK 6, PIN 7 |
| ch17 | BANK 1, PIN 2 | ch60 | BANK 3, PIN 13 | ch103 | BANK 6, PIN 8 |
| ch18 | BANK 1, PIN 3 | ch61 | BANK 3, PIN 14 | ch104 | BANK 6, PIN 9 |
| ch19 | BANK 1, PIN 4 | ch62 | BANK 3, PIN 15 | ch105 | BANK 6, PIN 10 |
| ch20 | BANK 1, PIN 5 | ch63 | BANK 3, PIN 16 | ch106 | BANK 6, PIN 11 |
| ch21 | BANK 1, PIN 6 | ch64 | BANK 4, PIN 1 | ch107 | BANK 6, PIN 12 |
| ch22 | BANK 1, PIN 7 | ch65 | BANK 4, PIN 2 | ch108 | BANK 6, PIN 13 |
| ch23 | BANK 1, PIN 8 | ch66 | BANK 4, PIN 3 | ch109 | BANK 6, PIN 14 |
| ch24 | BANK 1, PIN 9 | ch67 | BANK 4, PIN 4 | ch110 | BANK 6, PIN 15 |
| ch25 | BANK 1, PIN 10 | ch68 | BANK 4, PIN 5 | ch111 | BANK 6, PIN 16 |
| ch26 | BANK 1, PIN 11 | ch69 | BANK 4, PIN 6 | ch112 | BANK 7, PIN 1 |
| ch27 | BANK 1, PIN 12 | ch70 | BANK 4, PIN 7 | ch113 | BANK 7, PIN 2 |
| ch28 | BANK 1, PIN 13 | ch71 | BANK 4, PIN 8 | ch114 | BANK 7, PIN 3 |

Table 1. 128 x 1, 1-Wire Topology Terminal Mapping (Continued)

| Software Name | Hardware Name | Software Name | Hardware Name | Software Name | Hardware Name |
|---------------|----------------|---------------|----------------|---------------|----------------|
| ch29 | BANK 1, PIN 14 | ch72 | BANK 4, PIN 9 | ch115 | BANK 7, PIN 4 |
| ch30 | BANK 1, PIN 15 | ch73 | BANK 4, PIN 10 | ch116 | BANK 7, PIN 5 |
| ch31 | BANK 1, PIN 16 | ch74 | BANK 4, PIN 11 | ch117 | BANK 7, PIN 6 |
| ch32 | BANK 2, PIN 1 | ch75 | BANK 4, PIN 12 | ch118 | BANK 7, PIN 7 |
| ch33 | BANK 2, PIN 2 | ch76 | BANK 4, PIN 13 | ch119 | BANK 7, PIN 8 |
| ch34 | BANK 2, PIN 3 | ch77 | BANK 4, PIN 14 | ch120 | BANK 7, PIN 9 |
| ch35 | BANK 2, PIN 4 | ch78 | BANK 4, PIN 15 | ch121 | BANK 7, PIN 10 |
| ch36 | BANK 2, PIN 5 | ch79 | BANK 4, PIN 16 | ch122 | BANK 7, PIN 11 |
| ch37 | BANK 2, PIN 6 | ch80 | BANK 5, PIN 1 | ch123 | BANK 7, PIN 12 |
| ch38 | BANK 2, PIN 7 | ch81 | BANK 5, PIN 2 | ch124 | BANK 7, PIN 13 |
| ch39 | BANK 2, PIN 8 | ch82 | BANK 5, PIN 3 | ch125 | BANK 7, PIN 14 |
| ch40 | BANK 2, PIN 9 | ch83 | BANK 5, PIN 4 | ch126 | BANK 7, PIN 15 |
| ch41 | BANK 2, PIN 10 | ch84 | BANK 5, PIN 5 | ch127 | BANK 7, PIN 16 |



Note In the 128 × 1, 1-wire topology, 1WREF0 (BANK 0–1, PIN 17) is connected to COM1 (BANK 1, PIN 18).

Table 2. 64 x 1, 2-Wire Topology Terminal Mapping

| Software Name | Hardware Name | |
|---------------|----------------|----------------|
| | + | - |
| com0 | BANK 0, PIN 18 | BANK 1, PIN 18 |
| ch0 | BANK 0, PIN 1 | BANK 1, PIN 1 |
| ch1 | BANK 0, PIN 2 | BANK 1, PIN 2 |
| ch2 | BANK 0, PIN 3 | BANK 1, PIN 3 |
| ch3 | BANK 0, PIN 4 | BANK 1, PIN 4 |
| ch4 | BANK 0, PIN 5 | BANK 1, PIN 5 |
| ch5 | BANK 0, PIN 6 | BANK 1, PIN 6 |
| ch6 | BANK 0, PIN 7 | BANK 1, PIN 7 |
| ch7 | BANK 0, PIN 8 | BANK 1, PIN 8 |
| ch8 | BANK 0, PIN 9 | BANK 1, PIN 9 |
| ch9 | BANK 0, PIN 10 | BANK 1, PIN 10 |
| ch10 | BANK 0, PIN 11 | BANK 1, PIN 11 |
| ch11 | BANK 0, PIN 12 | BANK 1, PIN 12 |
| ch12 | BANK 0, PIN 13 | BANK 1, PIN 13 |
| ch13 | BANK 0, PIN 14 | BANK 1, PIN 14 |
| ch14 | BANK 0, PIN 15 | BANK 1, PIN 15 |
| ch15 | BANK 0, PIN 16 | BANK 1, PIN 16 |
| ch16 | BANK 2, PIN 1 | BANK 3, PIN 1 |
| ch17 | BANK 2, PIN 2 | BANK 3, PIN 2 |
| ch18 | BANK 2, PIN 3 | BANK 3, PIN 3 |
| ch19 | BANK 2, PIN 4 | BANK 3, PIN 4 |
| ch20 | BANK 2, PIN 5 | BANK 3, PIN 5 |
| ch21 | BANK 2, PIN 6 | BANK 3, PIN 6 |
| ch22 | BANK 2, PIN 7 | BANK 3, PIN 7 |
| ch23 | BANK 2, PIN 8 | BANK 3, PIN 8 |
| ch24 | BANK 2, PIN 9 | BANK 3, PIN 9 |
| ch25 | BANK 2, PIN 10 | BANK 3, PIN 10 |
| ch26 | BANK 2, PIN 11 | BANK 3, PIN 11 |
| ch27 | BANK 2, PIN 12 | BANK 3, PIN 12 |
| ch28 | BANK 2, PIN 13 | BANK 3, PIN 13 |

| Software Name | Hardware Name | |
|---------------|----------------|----------------|
| | + | - |
| ch32 | BANK 4, PIN 1 | BANK 5, PIN 1 |
| ch33 | BANK 4, PIN 2 | BANK 5, PIN 2 |
| ch34 | BANK 4, PIN 3 | BANK 5, PIN 3 |
| ch35 | BANK 4, PIN 4 | BANK 5, PIN 4 |
| ch36 | BANK 4, PIN 5 | BANK 5, PIN 5 |
| ch37 | BANK 4, PIN 6 | BANK 5, PIN 6 |
| ch38 | BANK 4, PIN 7 | BANK 5, PIN 7 |
| ch39 | BANK 4, PIN 8 | BANK 5, PIN 8 |
| ch40 | BANK 4, PIN 9 | BANK 5, PIN 9 |
| ch41 | BANK 4, PIN 10 | BANK 5, PIN 10 |
| ch42 | BANK 4, PIN 11 | BANK 5, PIN 11 |
| ch43 | BANK 4, PIN 12 | BANK 5, PIN 12 |
| ch44 | BANK 4, PIN 13 | BANK 5, PIN 13 |
| ch45 | BANK 4, PIN 14 | BANK 5, PIN 14 |
| ch46 | BANK 4, PIN 15 | BANK 5, PIN 15 |
| ch47 | BANK 4, PIN 16 | BANK 5, PIN 16 |
| ch48 | BANK 6, PIN 1 | BANK 7, PIN 1 |
| ch49 | BANK 6, PIN 2 | BANK 7, PIN 2 |
| ch50 | BANK 6, PIN 3 | BANK 7, PIN 3 |
| ch51 | BANK 6, PIN 4 | BANK 7, PIN 4 |
| ch52 | BANK 6, PIN 5 | BANK 7, PIN 5 |
| ch53 | BANK 6, PIN 6 | BANK 7, PIN 6 |
| ch54 | BANK 6, PIN 7 | BANK 7, PIN 7 |
| ch55 | BANK 6, PIN 8 | BANK 7, PIN 8 |
| ch56 | BANK 6, PIN 9 | BANK 7, PIN 9 |
| ch57 | BANK 6, PIN 10 | BANK 7, PIN 10 |
| ch58 | BANK 6, PIN 11 | BANK 7, PIN 11 |
| ch59 | BANK 6, PIN 12 | BANK 7, PIN 12 |
| ch60 | BANK 6, PIN 13 | BANK 7, PIN 13 |
| ch61 | BANK 6, PIN 14 | BANK 7, PIN 14 |

Table 2. 64 x 1, 2-Wire Topology Terminal Mapping (Continued)

| Software Name | Hardware Name | | Software Name | Hardware Name | |
|---------------|----------------|----------------|---------------|----------------|----------------|
| | + | - | | + | - |
| ch29 | BANK 2, PIN 14 | BANK 3, PIN 14 | ch62 | BANK 6, PIN 15 | BANK 7, PIN 15 |
| ch30 | BANK 2, PIN 15 | BANK 3, PIN 15 | ch63 | BANK 6, PIN 16 | BANK 7, PIN 16 |
| ch31 | BANK 2, PIN 16 | BANK 3, PIN 16 | | | |

Table 3. 32 x 1, 4-Wire Topology Terminal Mapping

| Software Name | Hardware Name | | | |
|---------------|----------------|----------------|----------------|----------------|
| | A+ | A- | B+ | B- |
| com0 | BANK 0, PIN 18 | BANK 1, PIN 18 | BANK 4, PIN 18 | BANK 5, PIN 18 |
| ch0 | BANK 0, PIN 1 | BANK 1, PIN 1 | BANK 4, PIN 1 | BANK 5, PIN 1 |
| ch1 | BANK 0, PIN 2 | BANK 1, PIN 2 | BANK 4, PIN 2 | BANK 5, PIN 2 |
| ch2 | BANK 0, PIN 3 | BANK 1, PIN 3 | BANK 4, PIN 3 | BANK 5, PIN 3 |
| ch3 | BANK 0, PIN 4 | BANK 1, PIN 4 | BANK 4, PIN 4 | BANK 5, PIN 4 |
| ch4 | BANK 0, PIN 5 | BANK 1, PIN 5 | BANK 4, PIN 5 | BANK 5, PIN 5 |
| ch5 | BANK 0, PIN 6 | BANK 1, PIN 6 | BANK 4, PIN 6 | BANK 5, PIN 6 |
| ch6 | BANK 0, PIN 7 | BANK 1, PIN 7 | BANK 4, PIN 7 | BANK 5, PIN 7 |
| ch7 | BANK 0, PIN 8 | BANK 1, PIN 8 | BANK 4, PIN 8 | BANK 5, PIN 8 |
| ch8 | BANK 0, PIN 9 | BANK 1, PIN 9 | BANK 4, PIN 9 | BANK 5, PIN 9 |
| ch9 | BANK 0, PIN 10 | BANK 1, PIN 10 | BANK 4, PIN 10 | BANK 5, PIN 10 |
| ch10 | BANK 0, PIN 11 | BANK 1, PIN 11 | BANK 4, PIN 11 | BANK 5, PIN 11 |
| ch11 | BANK 0, PIN 12 | BANK 1, PIN 12 | BANK 4, PIN 12 | BANK 5, PIN 12 |
| ch12 | BANK 0, PIN 13 | BANK 1, PIN 13 | BANK 4, PIN 13 | BANK 5, PIN 13 |
| ch13 | BANK 0, PIN 14 | BANK 1, PIN 14 | BANK 4, PIN 14 | BANK 5, PIN 14 |
| ch14 | BANK 0, PIN 15 | BANK 1, PIN 15 | BANK 4, PIN 15 | BANK 5, PIN 15 |
| ch15 | BANK 0, PIN 16 | BANK 1, PIN 16 | BANK 4, PIN 16 | BANK 5, PIN 16 |
| ch16 | BANK 2, PIN 1 | BANK 3, PIN 1 | BANK 6, PIN 1 | BANK 7, PIN 1 |
| ch17 | BANK 2, PIN 2 | BANK 3, PIN 2 | BANK 6, PIN 2 | BANK 7, PIN 2 |
| ch18 | BANK 2, PIN 3 | BANK 3, PIN 3 | BANK 6, PIN 3 | BANK 7, PIN 3 |
| ch19 | BANK 2, PIN 4 | BANK 3, PIN 4 | BANK 6, PIN 4 | BANK 7, PIN 4 |
| ch20 | BANK 2, PIN 5 | BANK 3, PIN 5 | BANK 6, PIN 5 | BANK 7, PIN 5 |
| ch21 | BANK 2, PIN 6 | BANK 3, PIN 6 | BANK 6, PIN 6 | BANK 7, PIN 6 |

Table 3. 32 x 1, 4-Wire Topology Terminal Mapping (Continued)

| Software Name | Hardware Name | | | |
|---------------|----------------|----------------|----------------|----------------|
| | A+ | A- | B+ | B- |
| ch22 | BANK 2, PIN 7 | BANK 3, PIN 7 | BANK 6, PIN 7 | BANK 7, PIN 7 |
| ch23 | BANK 2, PIN 8 | BANK 3, PIN 8 | BANK 6, PIN 8 | BANK 7, PIN 8 |
| ch24 | BANK 2, PIN 9 | BANK 3, PIN 9 | BANK 6, PIN 9 | BANK 7, PIN 9 |
| ch25 | BANK 2, PIN 10 | BANK 3, PIN 10 | BANK 6, PIN 10 | BANK 7, PIN 10 |
| ch26 | BANK 2, PIN 11 | BANK 3, PIN 11 | BANK 6, PIN 11 | BANK 7, PIN 11 |
| ch27 | BANK 2, PIN 12 | BANK 3, PIN 12 | BANK 6, PIN 12 | BANK 7, PIN 12 |
| ch28 | BANK 2, PIN 13 | BANK 3, PIN 13 | BANK 6, PIN 13 | BANK 7, PIN 13 |
| ch29 | BANK 2, PIN 14 | BANK 3, PIN 14 | BANK 6, PIN 14 | BANK 7, PIN 14 |
| ch30 | BANK 2, PIN 15 | BANK 3, PIN 15 | BANK 6, PIN 15 | BANK 7, PIN 15 |
| ch31 | BANK 2, PIN 16 | BANK 3, PIN 16 | BANK 6, PIN 16 | BANK 7, PIN 16 |

4. Install the Terminal Block

To connect the TB-2630 terminal block to the PXI-2530 front panel, complete the following steps.



Note The NI PXI-2530 should already be installed in a PXI chassis.

1. Plug the TB-2630 into the front connector of the PXI-2530.
2. Tighten the top and bottom chassis screws on the back of the terminal block rear panel to hold it securely in place.

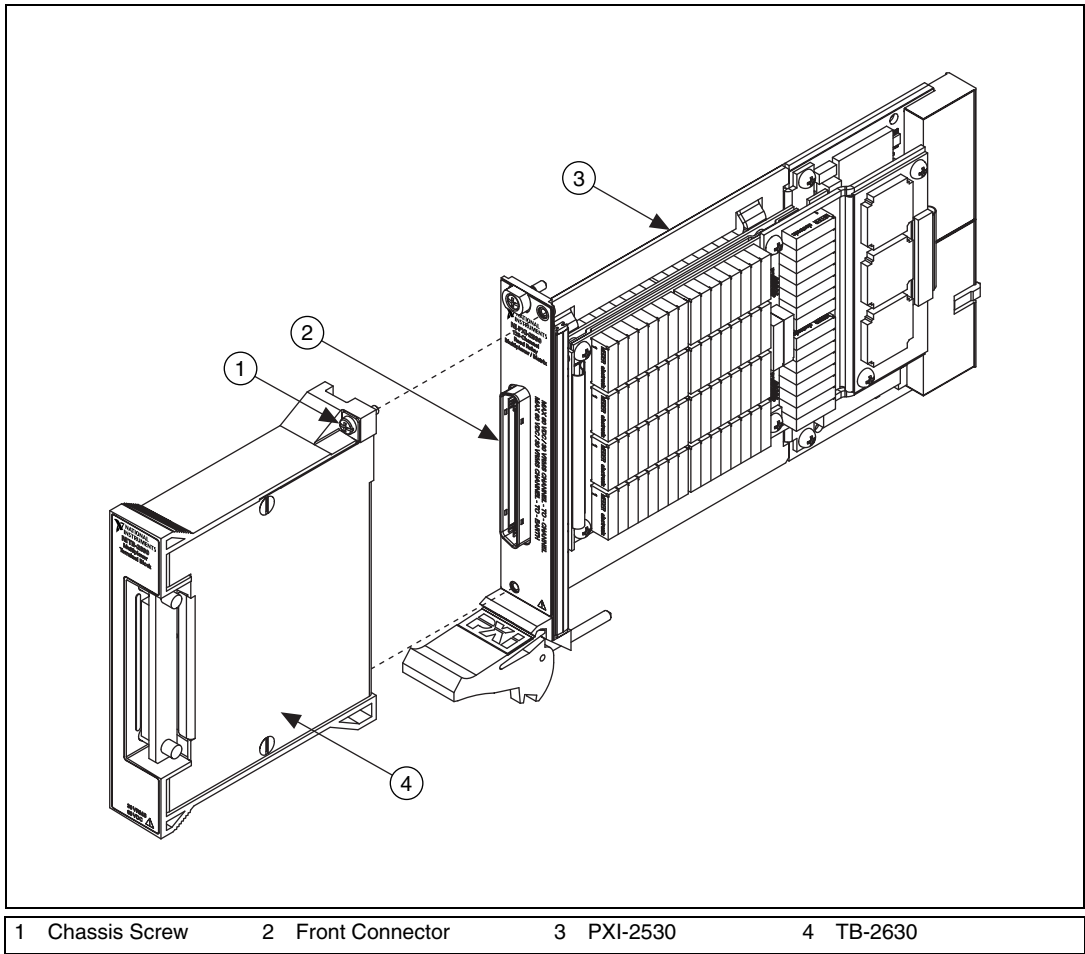

Figure 3. Installing the TB-2630 Terminal Block

Accessories

When a double row ribbon cable connector is used, the pitch of the ribbon cable is half the pitch of the connector. For example, a 0.050 in. pitch ribbon cable uses a 0.100 in. pitch connector. Ribbon cable connector assemblies are typically defined by the pitch of the connector. Refer to Figure 4 for a diagram of a 0.100 in. pitch cable assembly with a 0.100 in. pitch connector and a 0.050 in. pitch ribbon cable.

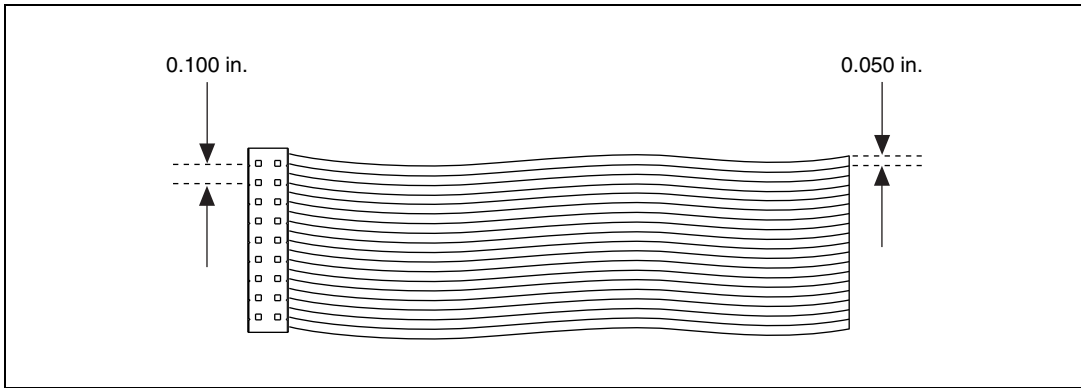

Figure 4. 0.100 in. Pitch Cable Assembly

The TB-2630 includes eight 2×9 0.100 in. pitch ribbon cable connectors. Refer to Table 4 for additional connectors that you can use with the TB-2630.

You can use any 0.050 in. pitch ribbon cable with the TB-2630. To use a ribbon cable with more than 18 conductors, remove the unwanted conductors before using. Refer to Table 4 for more information about the cable connector assembly.

Table 4. Third-Party Accessories for the TB-2630

| Accessory | Manufacturer | Part Number |
|---|--------------|----------------|
| 2×9 0.100 in. Pitch Ribbon Cable Connector | Samtec | IDD-09-HG |
| 0.100 in. Pitch Cable Connector Assembly (0.100 in. Pitch Connector and 0.050 in. Pitch Ribbon Cable) | Samtec | IDSD-09 Series |

Compliance and Certifications

Safety

This product is designed to meet the requirements of the following standards of safety for electrical equipment for measurement, control, and laboratory use:

- IEC 61010-1, EN 61010-1
- UL 3111-1, UL 61010B-1
- CAN/CSA C22.2 No. 1010.1



Note For UL and other safety certifications, refer to the product label or visit ni.com/hardref.nsf, search by model number or product line, and click the appropriate link in the Certification column.

Electromagnetic Compatibility

| | |
|-----------------|--|
| Emissions | EN 55011 Class A at 10 m FCC Part 15A above 1 GHz |
| Immunity | EN 61326:1997 + A2:2001, Table 1 |
| EMC/EMI..... | CE, C-Tick, and FCC Part 15 (Class A) Compliant |



Note For EMC compliance, operate this device with shielded cabling.

CE Compliance

This product meets the essential requirements of applicable European Directives, as amended for CE marking, as follows:

Low-Voltage Directive (safety) 73/23/EEC

Electromagnetic Compatibility
Directive (EMC) 89/336/EEC



Note Refer to the Declaration of Conformity (DoC) for this product for any additional regulatory compliance information. To obtain the DoC for this product, visit ni.com/hardref.nsf, search by model number or product line, and click the appropriate link in the Certification column.

National Instruments™, NI™, and ni.com™ are trademarks of National Instruments Corporation. Product and company names mentioned herein are trademarks or trade names of their respective companies. For patents covering National Instruments products, refer to the appropriate location: **Help» Patents** in your software, the `patents.txt` file on your CD, or ni.com/patents.

© 2003–2004 National Instruments Corp. All rights reserved.

373684B-01

Jun04